GBPPR 'Zine – Issue #4

Welcome to Green Bay Professional Packet Radio's (www.gbppr.org) crappy magazine!

Because *your* information wants to be free! Mine wants to be private...

Editor : multiplx zine@gbppr.org
Writers : GBPPR Staff
Distribution : <http://zine.gbppr.org>
Submissions : Don't even bother.
IRC Channel : #gbppr on irc.freenode.net No, I'm never around.

Table of Contents

- ◆ **Page 2 : Code 108 Test Lines (Loops) / 1A ESS**
 - ◇ Bell System Practice on loop-type test lines.
- ◆ **Page 22 : Lineman's Leg Climbers**
 - ◇ Bell System Practice on climbers/gaffs.
- ◆ **Page 33 : Longley–Rice Radio Path Loss Analysis**
 - ◇ Predict real-world path loss characteristics.
- ◆ **Page 40 : DMS–100 EXPIRED_PASSWORD_GRACE**
 - ◇ Parameter value for the OFCENG table.
- ◆ **Page 41 : DMS–100 MIN_PASSWORD_LENGTH**
 - ◇ Parameter value for the OFCENG table.
- ◆ **Page 42 : DMS–100 PASSWORD_LIFETIME**
 - ◇ Parameter value for the OFCENG table.
- ◆ **Page 43 : Use Old Cellular Phones to Jam Tape Recorders**
 - ◇ Use two old Motorola cellular phones to jam electronics.
- ◆ **Page 55 / Bonus**
 - ◇ Defective Plug–In Units tag
- ◆ **Page 56 / The End**
 - ◇ Editorial and Rants.

Copyright © 1990–2004 Green Bay Professional Packet Radio (GBPPR) under the GNU Free Documentation License

Code 108 Test Lines (Loops) / 1A ESS

BELL SYSTEM PRACTICES
AT&T Co SPCS

SECTION 231-090-404
Issue 2, April 1979

FEATURE DOCUMENT
CODE 108-TYPE TEST LINE FEATURE
2-WIRE NO. 1 AND NO. 1A ELECTRONIC SWITCHING SYSTEMS

CONTENTS	PAGE	CONTENTS	PAGE
<i>INTRODUCTION</i>	3	9. INSTALLATION/ADDITION/DELETION	14
1. GENERAL INFORMATION	3	10. HARDWARE REQUIREMENTS	14
2. DEFINITION/BACKGROUND	3	11. SOFTWARE REQUIREMENTS	14
<i>DESCRIPTION</i>	3	12. DATA ASSIGNMENTS AND RECORDS	18
3. USER OPERATION	3	13. TESTING	19
4. SYSTEM OPERATION	6	14. OTHER PLANNING TOPICS	19
<i>CHARACTERISTICS</i>	13	<i>ADMINISTRATION</i>	19
5. FEATURE ASSIGNMENT	13	15. MEASUREMENTS	19
6. LIMITATIONS	13	16. CHARGING	20
7. INTERACTIONS	13	<i>SUPPLEMENTARY INFORMATION</i>	20
8. RESTRICTION CAPABILITY	13	17. GLOSSARY	20
<i>INCORPORATION INTO SYSTEM</i>	14	18. REFERENCES	20

NOTICE

Not for use or disclosure outside the
Bell System except under written agreement

Printed in U.S.A.

Page 1

Code 108 Test Lines (Loops) / 1A ESS

SECTION 231-090-404

FIGURES	PAGE	FIGURES	PAGE
1. Functional Arrangement of the 108TL Feature	4	9. Layout of Incoming Trunk Test Registers	10
2. User Operation of the 108TL Feature	5	10. Procedure for Adding the 108TL Feature	15
3. Rate and Route Pattern Table Translator—Call Identification Word for Call Type 3	8		
4. DN Translator—DN Subtranslator—Type 4 Entry (Trunk)	8	TABLES	
5. Route Index Expansion Table Translator	8	A. 108TL Feature Hardware Data	7
6. Trunk Class Code Expansion Table Translator	9	B. 108TL Feature Hardware Usage Costs	17
7. TNN-to-PEN Auxiliary Blocks	9	C. No. 1 ESS Generic Program Words (108TL)	17
8. Master Scanner Translator	10	D. No. 1A ESS Generic Program Words (108TL)	18

Code 108 Test Lines (Loops) / 1A ESS

ISS 2, SECTION 231-090-404

INTRODUCTION

1. GENERAL INFORMATION

SCOPE

1.01 This feature document describes the code 108-type test line (108TL) feature when utilized with the No. 1 or No. 1A Electronic Switching System (ESS).

REASONS FOR REISSUE

1.02 The reasons for reissuing this section are listed below. Since this reissue is a general revision, no revision arrows have been used to denote significant changes.

- (1) Reformat contents from 23-part to 18-part format
- (2) Add coverage for HILO 4-wire switching feature
- (3) Add coverage for toll common channel interoffice signaling (CCIS) feature.

FEATURE AVAILABILITY

1.03 The 108TL feature is available in all issues of CTX-7 and later generic programs for No. 1 ESS, and 1AE1 and later generic programs for No. 1A ESS. The capability of accessing 108-type test lines without DN translations (via call type 3) is available in Issue 8 of CTX-7 and 1E3 for No. 1 ESS, and in 1AE1 for No. 1A ESS. For ESS offices equipped with the HILO 4-wire switching feature, the 108TL feature is available with 1E4 and later generic programs for No. 1 ESS, and 1AE4 and later generic programs for No. 1A ESS. For ESS offices equipped with the toll CCIS feature, the 108TL feature is available with 1E5 and later generic programs for No. 1 ESS, and 1AE5 and later generic programs for No. 1A ESS.

1.04 The 108TL feature software is contained in generic program base for 2-wire applications. HILO 4-wire and toll CCIS 108TL feature software is available in the HLAW and CCISTM feature packages, respectively.

2. DEFINITION/BACKGROUND

DEFINITION

2.01 The code 108-type test line (108TL) feature provides far-end loop-around termination for in-service testing of echo suppressors and is to be used with the 58-type echo suppressor measuring system (ESMS).

BACKGROUND

2.02 Echo suppressors may be required on certain regional center-to-regional center trunks, and should be used on interregional high-usage intertoll trunks, interregional toll connecting trunks, and end office toll trunks which have echo path delays exceeding specifications.

DESCRIPTION

3. USER OPERATION

CUSTOMER

3.01 Not applicable.

TELEPHONE COMPANY

3.02 The functional arrangement of the 108TL feature is shown in Fig. 1. No maintenance personnel actions (except routine equipment maintenance of 108-type test line(s)) are required in a No. 1 or No. 1A ESS office containing the 108TL feature (terminating end).

3.03 The user perspective of the way the 108TL feature is activated is presented from the maintenance personnel point of view at the originating (or near) end. The operation of the 108TL feature by near-end maintenance personnel is shown in Fig. 2. Refer to the applicable Equipment Test List and Method of Operation BSP documentation for more detailed information.

3.04 On non-CCIS trunk test calls, certain conditions cause the ESS to return failure signals to the near end. A 60-ipm signal is returned if the 108-type test line is busy, that is, both test port 0 and test port 1. If no calibration tone is received upon initial connection, maintenance personnel have actually reached test port 1 because test port 0 is already busy by another office. A 120-ipm signal is returned if the switching network is congested.

Page 3

Code 108 Test Lines (Loops) / 1A ESS

SECTION 231-090-404

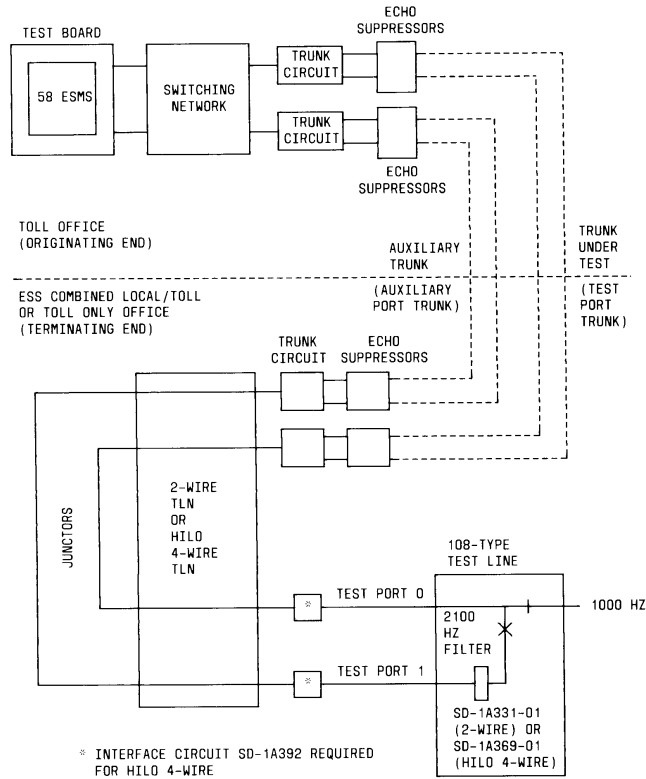

Fig. 1—Functional Arrangement of the 108TL Feature

no incoming trunk test registers are available, or if a peripheral order buffer failure occurs.

3.05 On toll CCIS trunk test calls, certain conditions cause the ESS to return failure messages to the near end. If the 108-type test line is busy (both ports 0 and 1), a national trunk congestion message is returned. If no calibration tone is

received upon initial connection, the test line is to be considered busy, and the clear forward message must be returned to the far end. A national switching congestion message is returned if the network is blocked, no incoming trunk test registers are available, or a peripheral order buffer failure occurs. If an invalid number is dialed, a vacant national number message is returned.

Code 108 Test Lines (Loops) / 1A ESS

ISS 2, SECTION 231-090-404

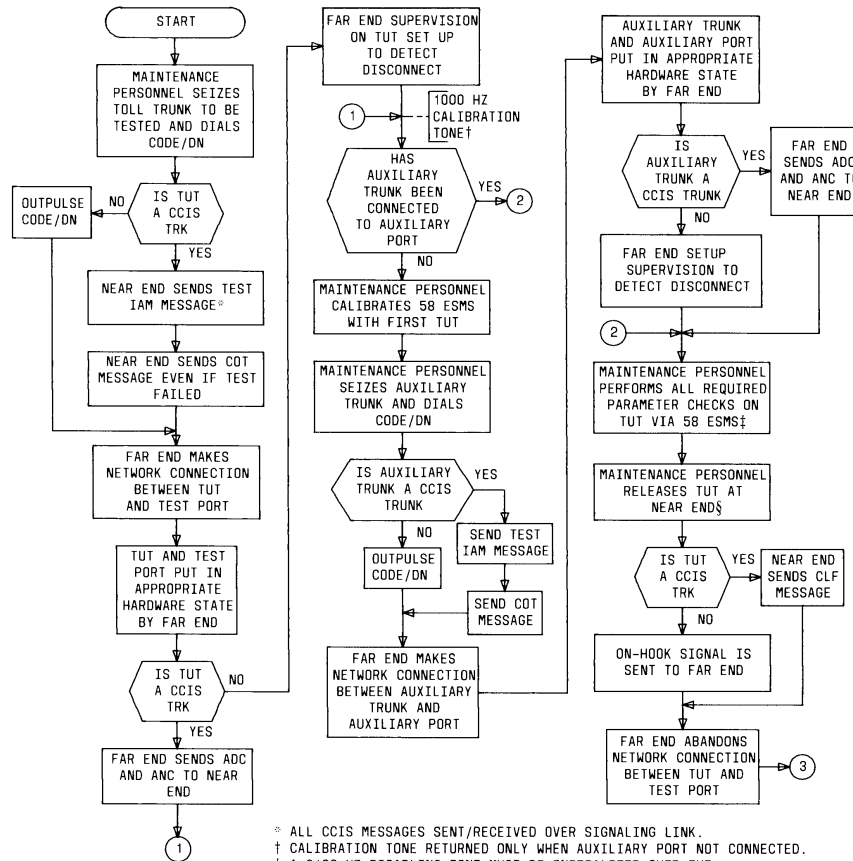

* ALL CCIS MESSAGES SENT/RECEIVED OVER SIGNALING LINK.
 † CALIBRATION TONE RETURNED ONLY WHEN AUXILIARY PORT NOT CONNECTED.
 ‡ A 2100 HZ DISABLING TONE MUST BE INITIALIZED OVER THE AUXILIARY TRUNK PRIOR TO TESTING BY MAINTENANCE PERSONNEL.
 § ASSUMES ALL TESTS PASS. OTHERWISE LEAVE TRUNK OUT OF SERVICE AND FOLLOW NORMAL MAINTENANCE PROCEDURES.

Fig. 2—User Operation of the 108TL Feature (Sheet 1)

Code 108 Test Lines (Loops) / 1A ESS

SECTION 231-090-404

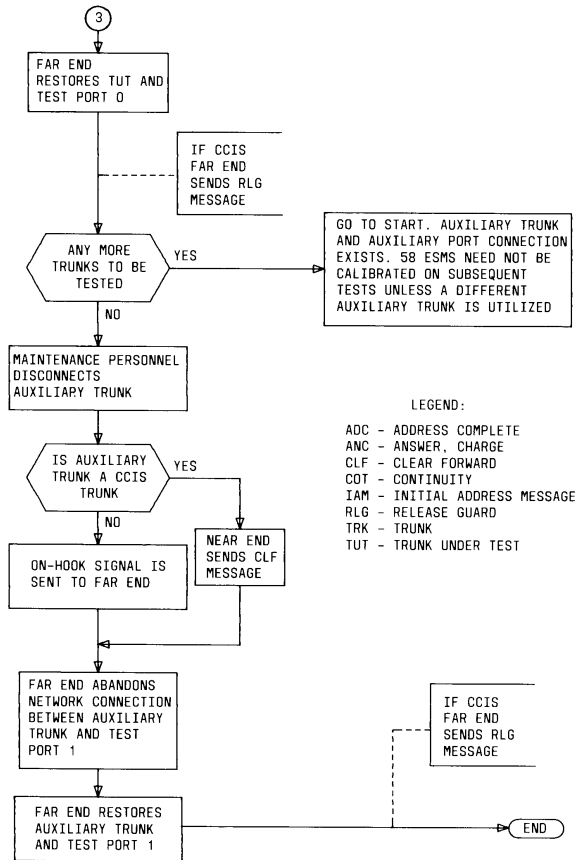

Fig. 2—User Operation of the 108TL Feature (Sheet 2)

4. SYSTEM OPERATION

HARDWARE

4.01 Hardware associated with the 108TL feature is shown in Table A. The function of a

2-wire test line is to provide a 108-type test termination for certain incoming 2-wire toll trunks. The function of a HILO 4-wire test line is to provide a 108-type test termination for certain incoming HILO 4-wire toll trunks. More technical information may be found in the appropriate Circuit Description

Code 108 Test Lines (Loops) / 1A ESS

ISS 2, SECTION 231-090-404

and Equipment Design Requirements BSP documentation for No. 1/1A ESS.

OFFICE DATA STRUCTURES

A. Translations

4.02 The 108TL feature uses the local/toll 3/6-digit translator to process an incoming 108-type test call. The code 108 can use a call type 3 translation [108 to route index (RI)], or a call type 28 translation (108 to DN translator). A DN translator (DN to RI) is also used for 7-digit test call processing. Call type 3 is the most efficient of the three methods. The result of all methods is to identify the applicable RI and to identify the incoming call as a test call. This is accomplished via the call indicator word for call type 3 shown in Fig. 3 where the RI is 178 and test (TST) item set to 1. RI 178 is only assigned to the 108TL feature. If the DN translator is used, a type 4 entry word

contains this information. The program index item is set to 1 to indicate a test call. Refer to Fig. 4.

4.03 For the 108TL feature for testing 2-wire toll trunks, RI 178 points the trunk under test (TUT) to the trunk group number (TGN) of test port 0 in its route index expansion table (Fig. 5). RI 179 is also assigned to the 108TL feature, and is used to point the auxiliary trunk to the TGN of test port 1. This also is accomplished in its route index expansion table. If the TGN for test port 0 is busy (as expected), the call is alternate routed to the TGN of test port 1. Both trunk groups contain only one trunk connected to a 2-wire 108-type test line.

4.04 For the 108TL feature for testing HILO 4-wire toll trunks, RI 178 will be correlated to pseudo route index (PRI) 010 in the PRI table. PRI 010 will contain a nonfixed RI which points to the TGN of test port 0 in its route index

TABLE A

108TL FEATURE HARDWARE DATA

ITEM	2-WIRE TEST LINE	HILO 4-WIRE TEST LINE*
Name	Electronic Switching System No. 1, Arranged for 2-Wire Features, Echo Suppressor Test Termination Circuit (108-Type)	Electronic Switching System Common, Arranged for 2-Wire Features, Echo Suppressor Test Termination Circuit (for HILO 4-Wire Switching)
SD Number	SD-1A331	SD-1A389
J Number	J1A033JR	J1A033MF
Frame	Miscellaneous Trunk Frame (MTF)	MTF
Mounting Space	2 inches	2 inches
Cable Length Limit	1190 Feet	1190 Feet
Number of Circuits per unit	1	1

* A HILO interface circuit is an integral part of HILO 4-wire trunk circuits for the HILO 4-wire switching feature, but is presented here for information purposes: SD-1A392; J1A090BH-1; Trunk Order Code 14200; HILO MTF or HILO universal trunk frame; plug-in; two circuits per unit.

Code 108 Test Lines (Loops) / 1A ESS

SECTION 231-090-404

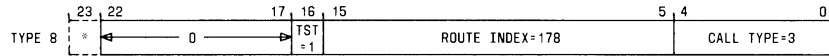

* BIT 23 DOES NOT EXIST IN THE TRANSLATION WORD FOR NO. 1 ESS. IT IS EQUAL TO 0 IN THE NO. 1A ESS. TST - TEST CALL

Fig. 3—Rate and Route Pattern Table Translator—Call Identification Word for Call Type 3

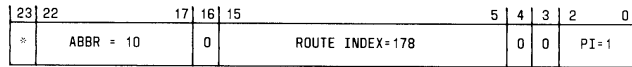

* BIT 23 DOES NOT EXIST IN THE TRANSLATION WORD FOR NO. 1 ESS. IT IS EQUAL TO 0 IN THE NO. 1A ESS. PI - PROGRAM INDEX. TEST CALL = 001
 ABBR - ABBREVIATED TERMINATING CODE
 PI - PROGRAM INDEX

Fig. 4—DN Translator—DN Subtranslator-Type 4 Entry (Trunk)

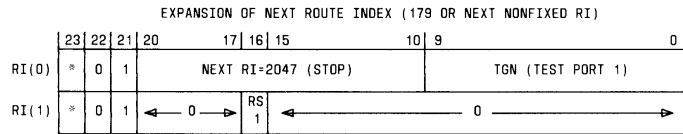
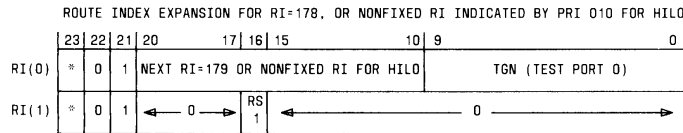

* BIT 23 DOES NOT EXIST IN THE TRANSLATION WORD FOR NO. 1 ESS. IT IS EQUAL TO 0 IN THE NO. 1A ESS.

PRI - PSUEDO ROUTE INDEX
 RI - ROUTE INDEX
 RS - RETURN SUPERVISION
 TGN - TRUNK GROUP NUMBER

Fig. 5—Route Index Expansion Table Translator

expansion table (Fig. 5). Another nonfixed RI will be assigned in the route index expansion table to alternate route to the TGN of test port 1 for the auxiliary trunk connection.

4.05 The trunk class code expansion table of the 108TL feature must provide trunk usage 3

and circuit program index (CPI) 110 for 2-wire 108-type test lines, or CPI 139 for HILO 4-wire 108-type test lines. See Fig. 6.

4.06 The trunk network number to peripheral equipment number (TNN-to-PEN) auxiliary block contains the information shown in Fig. 7.

Code 108 Test Lines (Loops) / 1A ESS

ISS 2, SECTION 231-090-404

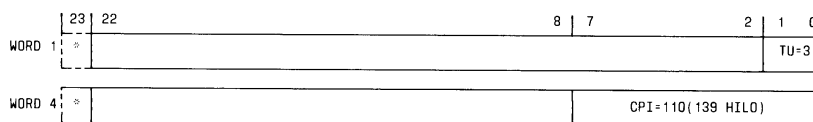

CPI - CIRCUIT PROGRAM INDEX
TU - TRUNK USAGE

* BIT 23 DOES NOT EXIST IN TRANSLATION WORDS FOR NO. 1 ESS
IT IS EQUAL TO 0 IN THE NO. 1A ESS

Fig. 6—Trunk Class Code Expansion Table Translator

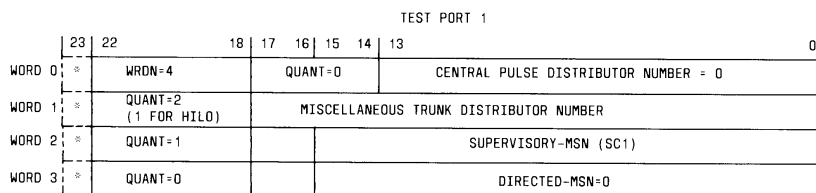
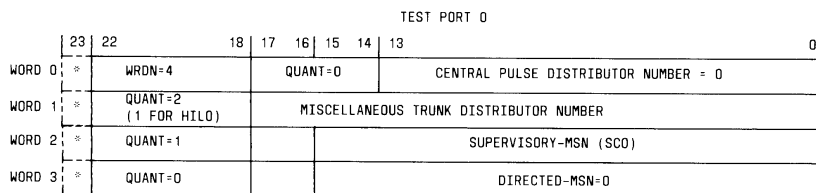

* BIT 23 DOES NOT EXIST IN TRANSLATION WORDS FOR NO. 1 ESS
IT IS EQUAL TO 0 IN THE NO. 1A ESS
QUANT - QUANTITY
WRDN - NUMBER OF WORDS IN AUXILIARY BLOCK

Fig. 7—TNN-to-PEN Auxiliary Blocks

4.07 The master scanner translator (Fig. 8) provides the trunk network number (TNN) and trunk program index 9.

B. Parameters/Call Store

4.08 Incoming trunk test registers (ITTRs) are required for processing certain trunk test calls. Refer to Fig. 9 for the layout of the registers for the 108TL feature.

FEATURE OPERATION

A. 2-Wire Trunk Testing (Non-CCIS Trunks)

4.09 The 108TL feature in the No. 1/1A ESS is designed to receive dialed code 108 or any assignable 7-digit DN, and to test 2-wire trunks in the tandem state only. Test point level is not relevant. The first dialing is for the connection of the TUT to test port 0 of the 2-wire 108-type

Code 108 Test Lines (Loops) / 1A ESS

SECTION 231-090-404



* BIT 23 DOES NOT EXIST IN THE TRANSLATION WORD FOR NO. 1 ESS. IT IS EQUAL TO 0 IN THE NO. 1A ESS. TPI - TRUNK PROGRAM INDEX
TNN - TRUNK NETWORK NUMBER

Fig. 8—Master Scanner Translator

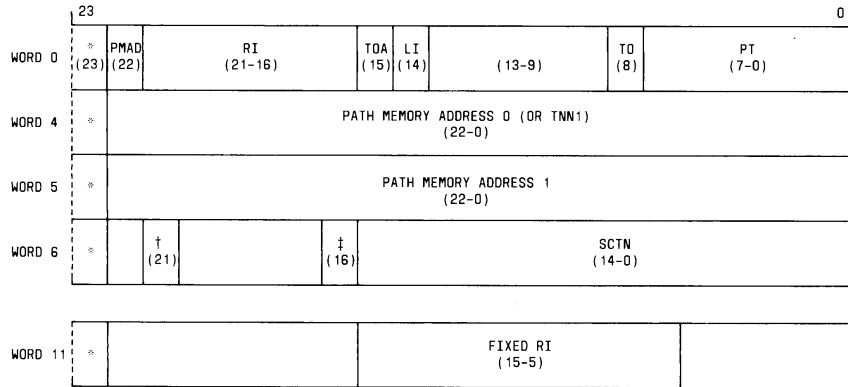

* BIT 23 DOES NOT EXIST IN THE TRANSLATION WORD FOR NO. 1 ESS IT IS EQUAL TO 0 IN THE NO. 1A ESS.

<p><u>WORD 0 (STATE WORD)</u> PT - PROGRAM TAG TO - REGISTER TIMEOUT FLAG PMFI - PATH MEMORY FORMAT INDICATOR LI - LINK WORD INDICATOR TOA - TIMEOUT ANNEX RI - REGISTER IDENTIFIER PMAD - PATH MEMORY ANNEX DISPLAY</p>	<p><u>WORD 6</u> SCTN - TNN OF TEST LINE † - 108TL = 1 ‡ - HILO 4-WIRE ICT = 1; 2-WIRE ICT=0</p>
---	---

A. NON-CCIS TRUNKS

Fig. 9—Layout of Incoming Trunk Test Register (Sheet 1)

test line; the second dialing is for the connection of the auxiliary trunk to test port 1. Once the connection to test port 1 is established and maintained, any subsequent dialing over another TUT will be reconnected to test port 0 again.

4.10 Normal call processing using call types 3, 28, or the DN translator will analyze and receive digits from an incoming 108-type test call. The DN subtranslator type 4 entry or call indicator word for call type 3 identifies the call as a test

Code 108 Test Lines (Loops) / 1A ESS

ISS 2, SECTION 231-090-404

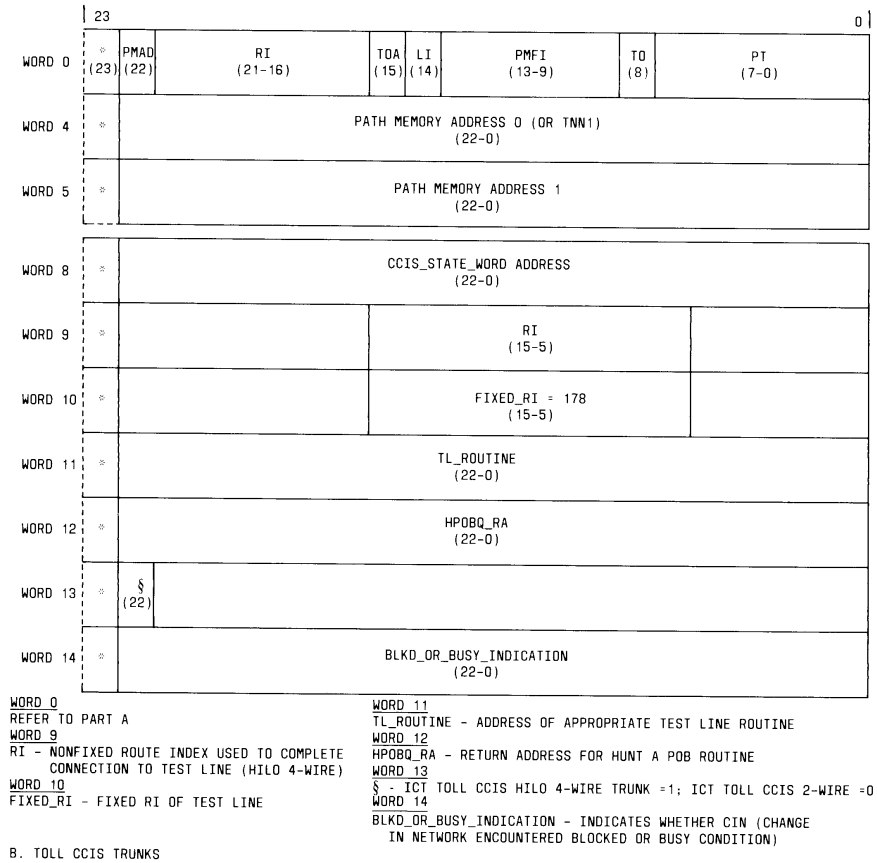

Fig. 9—Layout of Incoming Trunk Test Register (Sheet 2)

call and associates RI 178 with it. The associated incoming register is released, and an idle ITTR seized. Alternate routing to RI 179 for test port 1 via the route index expansion table is then allowed, and a correlation between RI 178 and its (test port 0) trunk group is made. This trunk group

contains only one trunk assigned to test port 0 of the 2-wire 108-type test line.

4.11 The system then abandons the applicable receiver connection and connects the TUT to the only applicable TNN. Refer to Fig. 1. The

Code 108 Test Lines (Loops) / 1A ESS

SECTION 231-090-404

TUT and test port 0 are put in the appropriate hardware state. Following this, supervision for disconnect is set up on the TUT via scanning and the master scanner translator. A 1000-Hz calibration tone is returned for the near end to calibrate its 58 ESMS. The tone will remain on this TUT until disconnect or connection of the auxiliary trunk to test port 1.

4.12 The second dialing over the auxiliary trunk is processed in a similar manner as above except that it is alternate routed to RI 179 (recall that test port 0 is still busy) for connection to test port 1 trunk group. At this time, calibration tone is removed from test port 0. Following application of a 2100-Hz disabling tone over the auxiliary trunk for disabling echo suppressors, maintenance personnel are ready to perform the seven required parameter checks on the TUT via the 58 ESMS.

4.13 After TUT disconnect by the near end, the ESS effects the following actions: idle the trunk and test port 0 hardware; abandon network connections; restore trunk and test port software, and release the applicable ITTR. Other trunks (to the ESS office) may be tested by simply redialing, connection to test port 0, and performing the parameter checks. No recalibration is necessary until a different auxiliary trunk is employed. Upon disconnect by the near end of the auxiliary trunk, the ESS also effects the above actions for test port 1.

4.14 Certain conditions cause the ESS to return failure signals to the near end. A 60-ipm signal is returned if the 108-type test line is busy, that is, both test port 0 and 1. (If no calibration tone is received upon initial connection, this means that the maintenance personnel have actually reached test port 1 instead of test port 0 because test port 0 is already busy by another office.) A 120-ipm signal is returned if the TLN is congested, no ITTRs are available, or if a peripheral order buffer fails.

B. HILO 4-Wire Trunk Testing (Non-CCIS Intertoll Trunks Only)

4.15 The operation of the 108TL feature in a No. 1/1A ESS equipped with the HILO 4-wire switching feature is very similar to the 2-wire trunk testing described above. However,

certain exceptions must be noted. These exceptions are the following:

- (a) HILO 4-wire trunks are tested in the talk state.
- (b) RI 178 correlates to PRI 010 which contains a nonfixed RI for test port 0 trunk group.
- (c) RI 179 does not exist for test port 1 trunk group. Instead the route index expansion of the nonfixed RI in the PRI table will contain another nonfixed RI for the test port 1 trunk group.
- (d) Supervision for disconnect will be set up by scanning the 108-type test line test ports.
- (e) Certain translation word data will be different.

C. Toll CCIS Trunk Testing (Intertoll Trunks Only)

4.16 In this operation description of the 108TL feature for a No. 1/1A ESS equipped with the toll CCIS switching feature, it should be remembered that the ESS may switch 2-wire and/or HILO 4-wire trunks, depending on how it is equipped, and that all interactive communications between offices is done over signaling links instead of toll trunks.

4.17 After the near-end maintenance personnel dials the appropriate digits, a test initial address message (IAM) is formatted and sent over the signaling link. The ESS then verifies the digits. If invalid, a vacant national number message is returned; if valid a continuity check circuit is connected to the TUT. A continuity (COT) test is automatically performed by the near-end switcher. Regardless of the COT results, the near end sends a COT message and the far end proceeds with the 108-type test call. The check circuit is abandoned, the incoming register released, and an idle ITTR seized. [If none available, ESS sends the national switching congestion (NSC) message. The near end must send the clear forward (CLF) message. The ESS then sends the release guard (RLG) message and the test call is terminated.]

4.18 From the digits 108 in the test IAM, the ESS determines RI 178 for the test port 0 trunk group. If HILO 4-wire, it correlates PRI 010 to obtain a nonfixed RI from the PRI table for the test port 0 trunk group. The TUT is then

Code 108 Test Lines (Loops) / 1A ESS

ISS 2, SECTION 231-090-404

CHARACTERISTICS

5. FEATURE ASSIGNMENT

5.01 The 108TL feature is to be provided on a toll office basis where incoming toll trunks equipped with echo suppressors terminate.

6. LIMITATIONS

OPERATIONAL

6.01 A 108-type test line is capable of being used by only one 58-type ESMS location at a time. Once the test and auxiliary ports are seized, the system gives all other attempts from different 58-type ESMS locations a busy trunk indication. Two 108-type test lines in an office (i.e., one 2-wire and one HILO 4-wire test line) may be operated simultaneously by the 108TL feature.

6.02 If two offices try to access a 108-type test line at the same time only one office receives calibration tone. The office not receiving calibration tone should abandon the seizure and retry at a later time.

ASSIGNMENT

6.03 One 108-type test line is needed per toll office where applicable, except in toll offices where both 2-wire and HILO 4-wire incoming toll trunks equipped with echo suppressors exist. In these situations the 108TL feature consists of two 108-type test lines, one 2-wire type and one HILO 4-wire type.

6.04 Every 108-type test line must be assigned two trunk groups, one for test port 0 and one for the test port 1. These trunk groups must not contain any other type of circuit.

6.05 The code 108 or any available 7-digit DN may be assigned the 108TL feature for dial access.

7. INTERACTIONS

7.01 Not applicable.

8. RESTRICTION CAPABILITY

8.01 Not applicable.

connected to the only TNN of the applicable test port 0 trunk group, the trunks are put into the appropriate hardware state, and an address complete, charge (ADC) and an answer, charge (ANC) message is returned. Toll CCIS trunks are tested in different test states than non-CCIS trunks. Toll CCIS 2-wire trunks are tested in tandem-talk-on-hook-with-transformer-or-2-dB-pack (TANONX) state. Toll CCIS HILO 4-wire trunks are tested in the continuity-check-state-on-hook-toward-trunk-HILO-4-wire (CNTN4) state. The 1000-Hz calibration tone is returned and remains until a CLF message is received or until connection of the auxiliary trunk to test port 1.

4.19 A second test IAM is formatted and sent over the auxiliary trunk, and is likewise processed by the ESS. When the system finds test port 0 TNN traffic busy, it alternate routes to RI 179 or nonfixed RI indicated in the applicable route index expansion table for connection to the test port 1 trunk group. The 108-type test line removes calibration tone from test port 0, maintenance personnel apply the 2100-Hz disabling tone, and then perform the 108-type parameter checks on the TUT via the 58 ESMS.

4.20 Upon test completion, the maintenance personnel releases the TUT which causes a CLF message to be sent to the far end. The ESS effects the following actions: idle the trunk and test port 0 hardware; abandon network connections; restore trunk and test port software; release the applicable ITTR; and return a RLG message. Other trunks may be tested by seizing another TUT, dialing, and repeating the above TUT procedure. No recalibration is necessary until a different auxiliary trunk is employed. Upon receipt of a CLF message for the auxiliary trunk, the ESS will also effect the above disconnect actions for test port 1.

4.21 Certain network conditions cause various ESS failure messages to be returned. If the test line (both ports 0 and 1) is busy, a national trunk congestion message is returned. (If no calibration tone is received upon initial connection, the test line is to be considered busy. The trunk should be idled immediately by sending the CLF message.) A NSC message is returned if the network is blocked, no ITTRs are available, or a peripheral order buffer failure occurs.

Page 13

Code 108 Test Lines (Loops) / 1A ESS

SECTION 231-090-404

INCORPORATION INTO SYSTEM

9. INSTALLATION/ADDITION/DELETION

9.01 Figure 10 illustrates the procedure to add the 108TL feature, providing the appropriate generic program exists in the office. Refer to paragraph 1.03.

10. HARDWARE REQUIREMENTS

COST FACTORS

10.01 Hardware usage costs for the 108TL feature are shown in Table B.

DETERMINATION OF QUANTITIES

10.02 Hardware associated with the 108TL feature is shown in Table A. One 2-wire 108-type test line is required per toll office for testing incoming 2-wire toll trunks with echo suppressors, if any. One HILO 4-wire 108-type test line is required per toll office for testing incoming HILO 4-wire toll trunks with echo suppressors, if any.

11. SOFTWARE REQUIREMENTS

COST FACTORS

A. Memory—No. 1 ESS

Fixed

11.01 The following memory is required whether or not the 108TL feature is used in a toll office.

- **Generic Program (program store):**
Refer to Table C.

- **Translations (program store):**

- (a) 1 word for PRI 010 (all offices equipped with 1E4 and later generic programs).
- (b) 4 words for RI expansion table for RI 178 and RI 179.

Conditional

11.02 The following memory is required per test line when the 108TL feature is activated in a toll office.

- **Generic Program (program store):**
Refer to Table C.

- **Translations (program store):**

- (a) 4 words for trunk class code expansion table
- (b) 1 word for DN subtranslator entry, if applicable
- (c) 1 word for each applicable type call identification word in the rate and route pattern auxiliary block
- (d) 2 words for master scanner translator
- (e) 8 words for TNN-to-PEN auxiliary block (4 words per port)
- (f) 4 words for RI expansion table for HILO 4-wire trunk testing capability.

- **Call Store**

- (a) The 108TL feature requires two ITTRs, each ITTR using 18 CS words for a total of 36 CS words per 108-type test line. Set card NITT defines the total number of ITTRs required by an office. A minimum of four ITTRs is required for all types of test lines in an office.

- (b) Peripheral order buffers are required to perform connection between the incoming toll trunks and 108-type test line. They are also used to place the trunk under test, auxiliary trunk, and the test line in the appropriate state during set up. These additions alone should not require any additional peripheral order buffers to be engineered for an office.

Variable

11.03 Not applicable.

B. Memory—No. 1A ESS

Fixed

11.04 The following memory is required whether or not the 108TL feature is used in a toll office.

Code 108 Test Lines (Loops) / 1A ESS

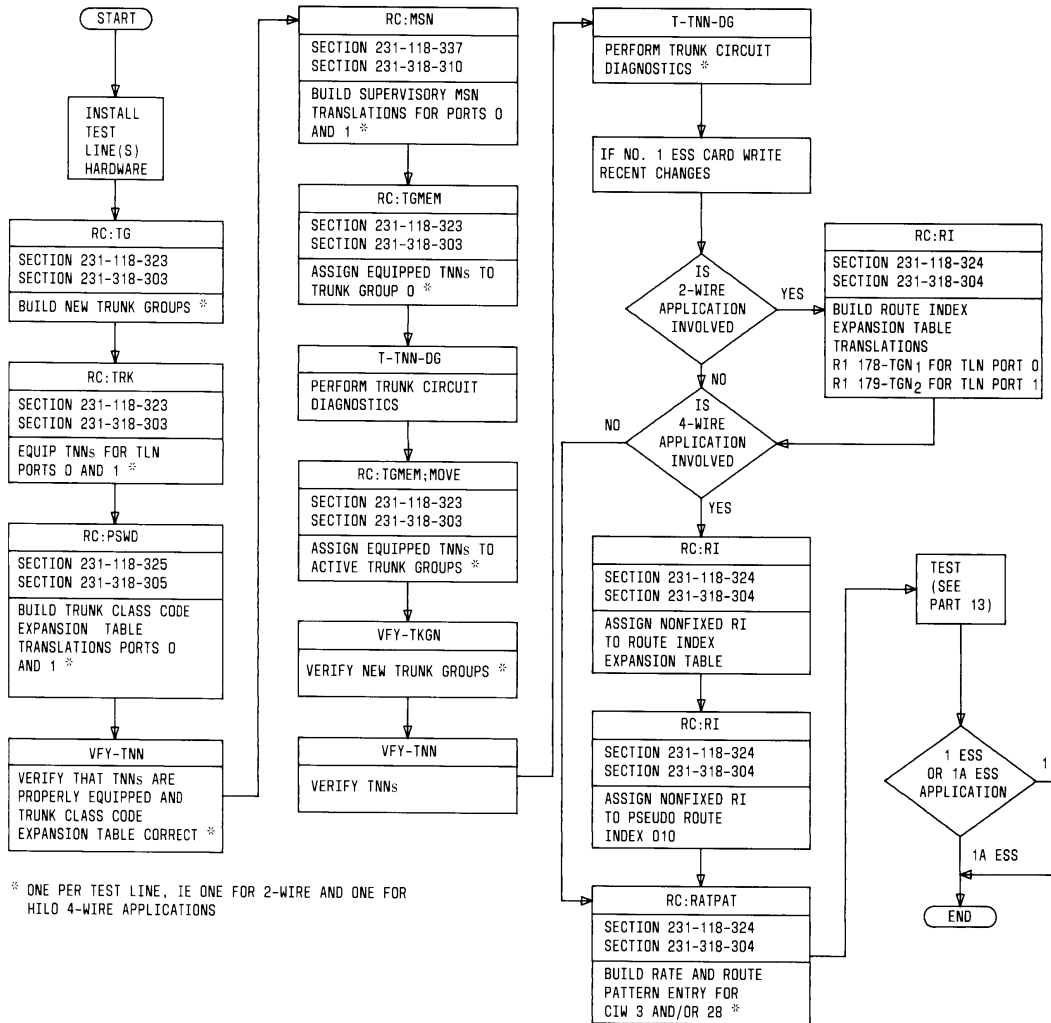

Fig. 10—Procedure for Adding the

Code 108 Test Lines (Loops) / 1A ESS

ISS 2, SECTION 231-090-404

TABLE B

108TL FEATURE HARDWARE USAGE COSTS

HARDWARE USAGE	SD-1A331 2-WIRE QUANTITIES	SD-1A389 HILO 4-WIRE QUANTITIES
Signal Distributor Points	4	2
Master Scan Points	2	2
Network Appearances	2*	2†
Required Trunk Groups	2	2
Trunk Order Code	11000	13900

* Transmission Reference Network

† Via HILO Interface Circuit, Trunk Order Code 14200

TABLE C

NO. 1 ESS GENERIC PROGRAM WORDS (108TL)

GENERIC PROGRAM	FIXED	CONDITIONAL		TOTAL
	2-WIRE (BASE)	HILO 4-WIRE (HL4W)*	TOLL CCIS (CCISTM)*	
Prior to 1E4	40	—	—	40
Effective with 1E4	40	35	—	75
Effective with 1E5	40	35	40	115

* Optionally loaded feature package.

• **Generic Program (program store, file store):** Refer to Table D.

• **Translation (program store):**

- (a) 1 word for PRI 010 (all offices)
- (b) 4 words for RI expansion table for RI 178 and RI 179.

Conditional

11.05 The following memory is required per test line when the 108TL feature is activated in a toll office.

• **Generic Program (program store, file store):** Refer to Table D.

• **Translation (unduplicated call store and file store):**

- (a) 4 words for trunk class code expansion table
- (b) 2 words for master scanner translator
- (c) 1 word for DN subtranslator entry, if applicable

Code 108 Test Lines (Loops) / 1A ESS

SECTION 231-090-404

TABLE D
NO. 1A ESS GENERIC PROGRAM WORDS (108TL)

GENERIC PROGRAM	FIXED	CONDITIONAL		
	2-WIRE (BASE)	HILO 4-WIRE (HL4W)*	TOLL CCIS (CCISTM)*	TOTAL
Prior to 1AE4	50	—	—	50
Effective with 1AE4	50	45	—	95
Effective with 1AE5	50	45	50	145

* Optionally loaded feature package.

- (d) 1 word for each applicable type call identification word in the rate and route pattern auxiliary block
- (e) 8 words for TNN-to-PEN each peripheral equipment auxiliary block (4 words per port)
- (f) 4 words for RI expansion table for HILO 4-wire trunk testing capability.

• **Call Store:**

- (a) The 108TL feature requires two ITTRs, each ITTR using 18 CS words for a total of 36 CS words per 108-type test line. Set card NITT defines the total number of ITTRs required by an office. A minimum of four ITTRs is required for all types of test lines in an office.
- (b) Peripheral order buffers are required to perform connection between the incoming toll trunks and 108-type test line. They are also used to place the trunk under test, auxiliary trunk, and the test line in the appropriate state during set up. These additions alone should not require any additional peripheral order buffers to be engineered for an office.

Variable

11.06 Not applicable.

Page 18

DETERMINATION OF QUANTITIES

11.07 Refer to COST FACTORS above.

PROCESSOR TIME

11.08 Each connection to the 108-type test line requires approximately 3500 processor cycles for No. 1 ESS, and approximately 7000 processor cycles for No. 1A ESS. The cycle time for No. 1 ESS is 5.5 μ sec. The cycle time for No. 1A ESS is 0.7 μ sec.

FEATURE DEFINING SET CARDS

11.09 Not applicable.

12. DATA ASSIGNMENTS AND RECORDS

TRANSLATION FORMS

12.01 ESS translation forms, found in reference C(1) in Part 18 requiring completion are as follows:

- (a) ESS 1101—Directory Number Record: This form assigns program index for directory numbers employing a route index for completion.
- (b) ESS 1201—Miscellaneous Trunk Frame Record: This form relates the equipment location on a frame basis with the trunk network number (TNN), the trunk group, the trunk number, the trunk class code, and CPD points. This form also contains records of signal distributor points

Code 108 Test Lines (Loops) / 1A ESS

ISS 2, SECTION 231-090-404

and supervisory, direct, fast, and common scan points associated with the trunk group.

(c) ESS 1202—Trunk Group Record: This form is used to furnish TNN to trunk group and trunk number translations for all trunks.

(d) ESS 1203—Trunk Network Number Record: This form relates the TNN to the trunk group and trunk frame location.

(e) ESS 1204—Trunk Class Code Data: Specifies data for trunk class code expansion tables.

(f) ESS 1220—Universal Trunk Frame (HILO) Record: Relates the HILO universal trunk equipment locations on a frame basis to the corresponding trunk network appearances and the HILO universal trunks assigned to these equipment locations.

(g) ESS 1303 A/B/C Trunk and Service Circuit Route Index Record: This form assigns route index, next route index, and return supervision to trunk groups containing test lines.

(h) ESS 1303D—Pseudo Route Index Record: Specifies data for pseudo route indexes for HILO 4-wire 108TL feature.

(i) ESS 1305—Rate and Route Pattern Record: This form enables simulated dialing of 7-digit directory numbers after receiving a 108-type test code via call type 28 in call identification word or provides a route index to complete the call for special use of call type 3.

(j) ESS 1311—Toll Three/Six-Digit Translations: This form establishes routings for incoming 3- and 6-digit toll codes via rate and route pattern number pointing to a call identification word (1305).

RECENT CHANGES

12.02 Not applicable.

13. TESTING

13.01 Verification that the 108TL feature has been properly installed and assigned can be accomplished by the following input/output messages (abbreviated from the appropriate input/output message manual referenced in Part 18B).

System responses should be checked against the applicable ESS translation form data.

(a) For No. 1 ESS T-READ input message is used to verify trunk class code expansion table entries. System response should be a TW02 output message. For No. 1A ESS use DUMP:CSS, ADR— to verify the call indicator words. The system response is DUMP:CSS output message.

(b) Type in on maintenance TTY the VFY-EXP input message to verify the route index (or pseudo route index). Refer to output message TR05 for system responses.

(c) Type in on maintenance TTY the VFY-MSN input message to verify the master scanner number. Refer to output message TR12 for system responses.

(d) Type in on maintenance TTY the VFY-TRGN input message to verify trunk group numbers. Refer to output message TR10 for system responses.

(e) Type in on maintenance TTY the VFY-TNN input message to verify a trunk network number translation. Refer to output message TR14 for system responses.

13.02 Incoming 108-type test calls should be made over various trunk groups to verify proper operation of the 108TL feature.

13.03 The 108-type test line circuits are diagnosed routinely and on-demand by an ESS. Routine testing is done through automatic progression testing. Demand testing is accomplished from an ESS test position or teletypewriter. Refer to reference A(20) in Part 18.

14. OTHER PLANNING TOPICS

14.01 Refer to the applicable SD drawing for the particulars concerning nominal power requirements.

ADMINISTRATION

15. MEASUREMENTS

15.01 None.

Page 19

Code 108 Test Lines (Loops) / 1A ESS

SECTION 231-090-404

16. CHARGING

16.01 Not applicable.

SUPPLEMENTARY INFORMATION

17. GLOSSARY

Echo Suppressor A voice-operated switching device that reduces echo by introducing loss in the return transmission path of a 4-wire trunk.

18. REFERENCES

18.01 The following documentation contains information pertaining to or affected by the 108TL feature.

A. Bell System Practices

- (1) Section 103-105-110—58-Type Echo Suppressor Measuring System (J68658) Description
- (2) Section 103-105-310—58-Type Echo Suppressor Measuring System (J68658) Operations
- (3) Section 103-105-510—58-Type Echo Suppressor Measuring System, J68658, Near-End Equipment, Tests and Adjustments
- (4) Section 231-061-210—Service Circuits, Network Design—No. 1 Electronic Switching System
- (5) Section 231-061-220—Trunk and Miscellaneous Circuits, Network Design—No. 1 Electronic Switching System
- (6) Section 231-061-450—Program Stores, Network Design—No. 1 Electronic Switching System
- (7) Section 231-061-460—Call Stores, Network Design—No. 1 Electronic Switching System
- (8) Section 231-062-210—Service Circuits, Network Design—No. 1A Electronic Switching System
- (9) Section 231-062-220—Trunks and Miscellaneous Circuits, Network Design—No. 1A Electronic Switching System

(10) Section 231-062-460—Processor Community Engineering, Program Stores, Network Design—No. 1A Electronic Switching System

(11) Section 231-062-465—Processor Community Engineering, Duplicated Call Store, Network Design—No. 1A Electronic Switching System (when published)

(12) Section 231-062-470—Processor Community Engineering, Unduplicated Call Store, Network Design—No. 1A Electronic Switching System

(13) Section 231-062-475—Processor Community Engineering, File Stores, Network Design—No. 1A Electronic Switching System

(14) Section 231-090-366—Feature Document—HILO 4-Wire Switching Feature, 2-Wire No. 1 and No. 1A Electronic Switching Systems

(15) Section 231-090-416—Feature Document—Toll Common Channel Interoffice Signaling Feature, 2-Wire No. 1 and No. 1A Electronic Switching System

(16) Section 231-118-323—Trunk Translation Recent Change Procedures for TG, TGBVT, TRK, CFTRK, and TGMEM (CTX-6 through 1E5 Generic Programs), 2-Wire No. 1 Electronic Switching System

(17) Section 231-118-324—Rate and Route Translation Recent Change Procedures for NOCNOG, DNHT, NOGRAC, RATPAT, DIGTRN, TOLDIG, CCOL, RI, CHRGX, DITABS, TNDM, IDDD, and TDXD (CTX-6 through 1E5 Generic Programs), 2-Wire No. 1 Electronic Switching System

(18) Section 231-118-325—RC Procedures for PSWD, GENT, PSBLK, SUBTRAN (CTX-6 through 1E5 Generic Programs), 2-Wire No. 1 Electronic Switching System

(19) Section 231-118-337—RC Procedures for ANIDL, CAMA, CFG, CPD, MSN, NMTGC, PLM, ROTL, SIMFAC, and TMGCGA (CTX-6 through 1E5 Generic Programs), 2-Wire No. 1 Electronic Switching System

Code 108 Test Lines (Loops) / 1A ESS

ISS 2, SECTION 231-090-404

- (20) Section 231-130-101—Trunk Test Capabilities Description—2-Wire No. 1 Electronic Switching System
- (21) Section 231-318-303—Trunk Translation Recent Change Procedures for TG, TGBVT, TRK, CFTRK, and TGMEM (Through 1AE5 Generic Program), 2-Wire No. 1A Electronic Switching System
- (22) Section 231-318-304—Rate and Route Translation Recent Change Procedures for NOCNOG, DNHT, NOGRAC, RATPAT, DIGTRN, TOLDIG, CCOL, RI, CHRGX, DITA8S, TNDM, IDDD, and TDXD (Through 1AE5 Generic Program), 2-Wire No. 1A Electronic Switching System
- (23) Section 231-318-305—RC Procedures for PSWD, PSBLK, SUBTRAN, and GENT (Through 1AE5 Generic Program), 2-Wire No. 1A Electronic Switching System
- (24) Section 231-318-310—RC Procedures for ANIDL, CAMA, CPD, JUNCT, MSN, NMTGC, PLM, ROTL, SIMFAC, CFG, and TMBCGA (Through 1AE5 Generic Program), 2-Wire No. 1A Electronic Switching System
- (25) Section 660-440-010—Codes—Test Line Circuits and Communication Trunks Nationwide Distance Dialing Plan.

B. TTY Input and Output Manuals

- (1) TTY Input Message Manual IM-1A001, No. 1 Electronic Switching System
- (2) TTY Output Message Manual OM-1A001, No. 1 Electronic Switching System
- (3) TTY Input Message Manual IM-6A001, No. 1A Electronic Switching System
- (4) TTY Output Message Manual OM-6A001, No. 1A Electronic Switching System

C. Other Documentation

- (1) Translation Guide TG-1A, No. 1 and No. 1A Electronic Switching Systems—2-Wire
- (2) Office Parameter Specification PA-591001, No. 1 Electronic Switching System—2-Wire
- (3) Office Parameter Specification PA-6A001, No. 1A Electronic Switching System—2-Wire
- (4) Translation Output Configuration PA-591003, No. 1 Electronic Switching System—2-Wire
- (5) Translation Output Configuration PA-6A002, No. 1A Electronic Switching System—2-Wire
- (6) Parameter Guide PG-1—No. 1 Electronic Switching System.

Page 21
21 Pages

Lineman's Leg Climbers

BELL SYSTEM PRACTICES
AT & TCo Standard

SECTION 081-730-101
Issue 4, June 1976

CLIMBERS

	CONTENTS	PAGE
1. GENERAL		1
2. DESCRIPTION		1
F CLIMBERS—AT-8530		1
D AND E CLIMBERS		2
SLEEVES		3
PADS		3
STRAPS		4
GAFF GUARDS		4
3. FITTING AND ASSEMBLING CLIMBERS		4
4. PRECAUTIONS		5
5. INSPECTION OF CLIMBERS		6
6. TESTING CLIMBER GAFFS		8
7. FIELD MAINTENANCE		9
CLIMBER GAFFS		9
PADS		11

1. GENERAL

1.01 This section describes climbers and associated items such as pad, straps, and gaff guards. Information on the care and maintenance of these items is included.

1.02 This section is reissued to change inspection frequency, to provide new pictures, and to cancel Section 460-300-105. Arrows are used to indicate changes.

1.03 When existing D, E, and F climbers with foot straps attached to a solid ring are returned for reconditioning, the solid ring will be replaced with a split steel ring.

1.04 *Under no circumstances should a file or any other tool be used to reshape or sharpen a climber gaff.* Part 7 describes the use of a hone for climber gaff maintenance.

2. DESCRIPTION

F CLIMBERS—AT-8530

2.01 The F climber is an adjustable length climber that consists of a leg iron, an adjustable sleeve, fasteners and gaff guards. The parts of an F climber are shown in Fig. 1.

2.02 The F climber is basically identical in construction to the D or E climbers. The foot strap assembly which secures the stirrup of the climber to the arch of the shoe is equipped with a removable split steel ring and is not an integral part of the climber.

2.03 Gaffs of F climbers are fully machine shaped and sharpened. The climber shank is tapped and threaded for adjusting and securing the sleeve at any desired position (see 2.07 and 2.08). The adjustable sleeves are interchangeable. The gaff is designed so it can be machine sharpened without any filing to reshape the outer rounded surfaces or the ridge of the gaff. *Do not use a file on these surfaces at any time.* This would disturb the original design of gaff so that it cannot be machine sharpened satisfactorily.

2.04 Climbers can be ordered with or without sleeves. Sleeves and fasteners can be ordered separately. Pads, leg straps, and foot strap assemblies or foot strap components must be ordered separately. Gaff guards may be ordered separately; however, all new and factory resharpened climbers are returned with gaff guards installed.

NOTICE

Not for use or disclosure outside the
Bell System except under written agreement

Printed in U.S.A.

Page 1

Lineman's Leg Climbers

SECTION 081-730-101

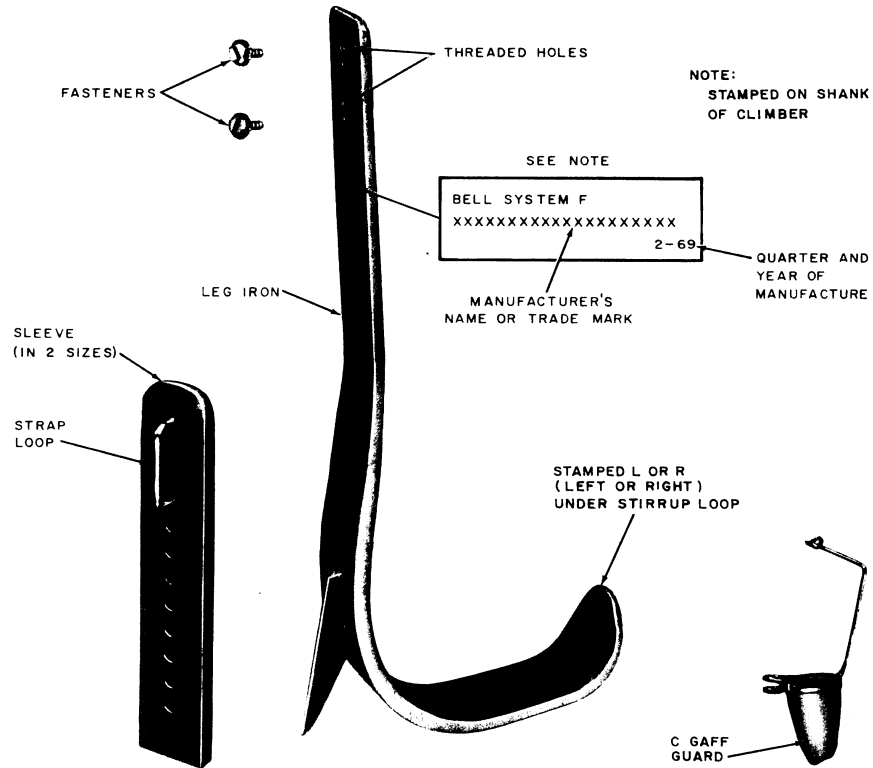

Fig. 1—Parts for F Climber

2.05 F climbers have offset stirrups, therefore, they are made for the left or right foot and are marked "L" or "R" just below the ring loop at the end of the stirrup. Some older climbers may not have been marked. Climbers can be identified as left or right by holding the climber with the gaff toward you and pointing up and noting the direction the stirrup is offset. If the offset is to the right as shown in Fig. 2, it is a

right climber; conversely, if the offset is to the left, it is a left climber.

D AND E CLIMBERS

2.06 The superseded D and E climbers are basically identical to the F climber except that on these climbers the C and D foot straps have been rated "Manufacture Discontinued." These foot

Lineman's Leg Climbers

ISS 4, SECTION 081-730-101

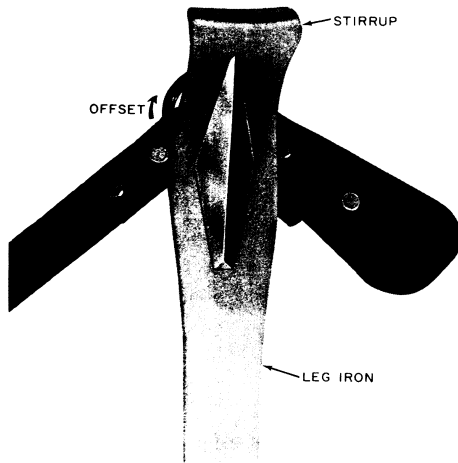

Fig. 2—Stirrup Offset "Right"

straps have been replaced by the E climber foot strap.

SLEEVES

2.07 The sleeves used on adjustable climbers are designed to fit snugly over the shank of the leg irons and to be securely locked in the desired position by fasteners. The sleeves are available in two lengths and can be adjusted in increments of 1/4 inch. Figure 3 illustrates the sleeves, the lengths available, and the adjustment range of each sleeve.

2.08 The sleeves are attached to the climbers with two hexagon head machine screws known as fasteners, except on the shorter adjustments of 14 3/4 inches to 15 1/2 inches for the short sleeve and 17 3/4 inches to 18 1/2 inches for the long sleeves. On these adjustments, only one setscrew is used for attachment. For these lengths, the wedging of the sleeve and leg iron provides a sufficiently tight fit on the lower part of the sleeve. The fasteners are inserted through the holes in the sleeves from the side with the strap loop and secured in the threaded holes of the leg

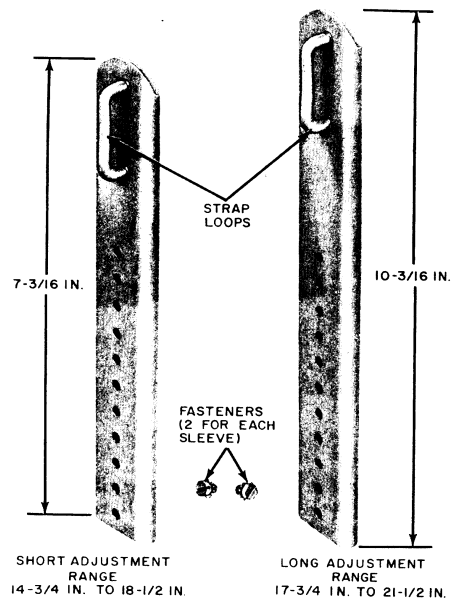

Fig. 3—Sleeves for Adjustable Climbers

irons. The heads of the machine screws are slotted for tightening with a screwdriver. The fasteners are equipped with spring steel lockwashers.

PADS

2.09 Pads are used with climbers to protect the shins and calf of the leg against irritation by rubbing when the climbers are strapped to the legs. Plain leather, felt lined, and cushioned pads are available as shown in Fig. 4. Cushion pads are coded B climber pads (angle) and C climber pads (straight). The plain and felt lined pads are generally used when wearing boots that cover the calf of the leg. The wrap-around design of the B climber pads furnishes additional protection at the shins. Occasionally the top edge of a new pad may initially dig into the leg in use. This can be overcome by dulling the top edge by rubbing with a rounded metal tool.

Page 3

Lineman's Leg Climbers

SECTION 081-730-101

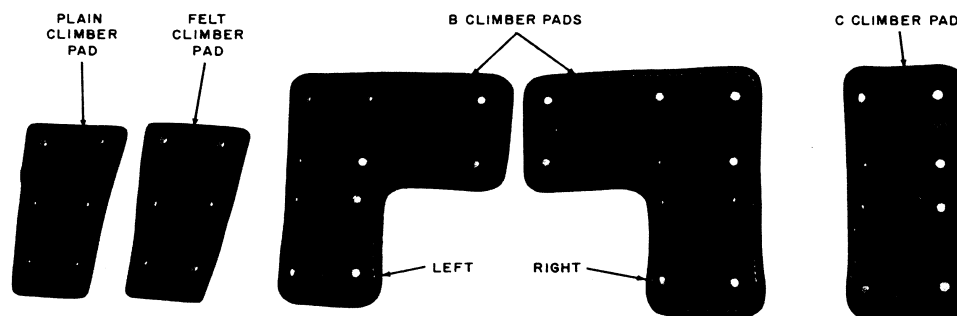

Fig. 4—Pads

STRAPS

2.10 The foot straps are attached to the climber so the buckle assembly will be across the foot instep when fastened. Figure 5 shows the foot strap on the climber.

2.11 The B climber strap (Fig. 6) consists of a 22- or 26-inch strap with a buckle permanently attached. The B climber strap is used to hold the pad on the leg iron and to fasten both to the employee's leg when the climber is worn.

GAFF GUARDS

2.12 Gaff guards are used to protect gaffs and employees when climbers are not being used. They also protect other tools from damage that are stored in the vicinity of climbers. Figure 7 shows the gaff guard installed.

3. FITTING AND ASSEMBLING CLIMBERS

3.01 Determine the correct sleeve to use by measuring the distance from the lower edge of the projecting kneebone to the underside of the shoe at the arch as shown in Fig. 8 and subtract 1/2 inch from this length. Select the climber sleeve that covers this range (2.07, Fig. 3). When ready to assemble the climber for use, proceed as follows:

- (1) Place the split steel ring of the E climber foot strap on the climber stirrup loop and

then place the foot strap and buckle assembly on the split ring.

- (2) Place the B climber strap and pad on the sleeve as shown in Fig. 6. The strap should be placed so the tongue will point toward the back of the leg when buckled.

- (3) Place the sleeve on the shank of the climber step on the stirrup and buckle the foot strap so the stirrup is held firmly against the arch of the shoe. Adjust the sleeve to a position that is most comfortable.

- (4) Place one of the slotted hexagon head setscrews through the hole in the sleeve that is aligned with the threaded holes in the climber and tighten the setscrew to hold the sleeve in place.

- (5) Strap the climber to the leg as shown in Fig. 9 to see if it feels comfortable. Climber should be adjusted to the maximum length which is most comfortable.

- (6) If the climber feels comfortable, remove the climber and add the second setscrew (see 2.08) and tighten both screws to hold the sleeves securely. If uncomfortable, move the setscrews up or down one hole on the sleeve as required to find the most comfortable position.

- (7) Repeat the procedure for the other climber.

Lineman's Leg Climbers

ISS 4, SECTION 081-730-101

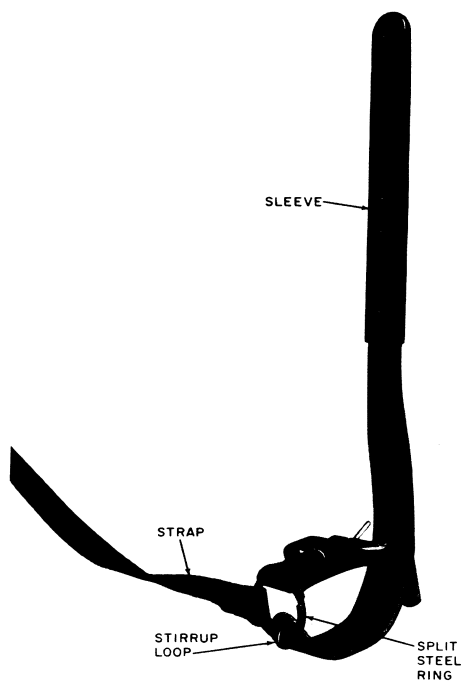

Fig. 5—Foot Straps Attached to Climbers

4. PRECAUTIONS

4.01 Observe the following precautions when storing, transporting, and using climbers:

- (a) Equip climbers with gaff guards, when not in use. Gaff guards protect employees as well as the gaff tips and cutting edges when climbers are carried or are stored in tool boxes or other storage spaces. They also prevent damage to safety straps and body belts when stored in the same compartments with climbers.
- (b) Use climbers adjusted to correct size. (See part 3).

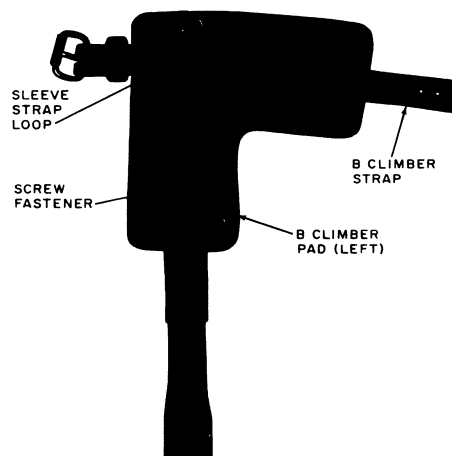

Fig. 6—B Climber Strap and Pad Installed on Climber

- (c) Do not bend leg irons. If discomfort exists, use cushion type pads.
- (d) **Never wear climbers on work where they are not required** as, when walking between poles, when working on the ground, a ladder, an aerial lift, a stepped pole where the work can be performed safely from the steps, in trees, or while traveling in a motor vehicle or any other type of conveyance.
- (e) When climbing past another employee who has his safety strap in place around the pole, special care should be taken to avoid gaffing the other employee, his safety strap, or other equipment.
- (f) When climbing past attachments on poles, care should be taken to avoid dragging climbers or foot against these attachments.
- (g) Do not use the gaff as a pry.
- (h) When climbing, avoid placing the gaff in or near a crack, knot, nail, or tack, etc.
- (i) Inspect climbers in accordance with part 5.

Page 5

Lineman's Leg Climbers

SECTION 081-730-101

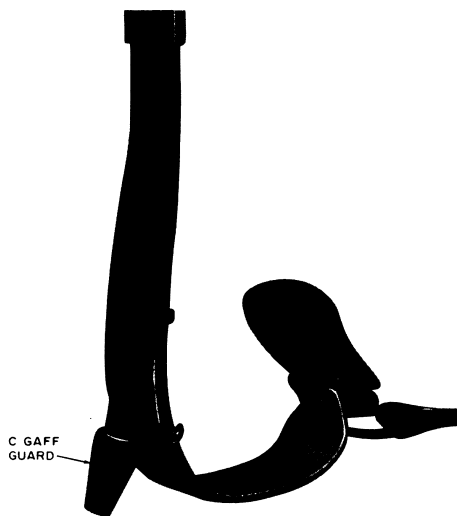

Fig. 7—C Gaff Guard Installed



Fig. 8—Measuring for Climber Length

5. INSPECTION OF CLIMBERS

5.01 Each employee shall assume the responsibility for determining that his climbers, sleeves, pads, straps, gaffs, and gaff guards are in good condition. Upon receipt of the climbers and at least once each day before they are used, the employee shall inspect the climbers and associated items in accordance with 5.03 to detect any flaw that may have developed. In addition, the climber shall pass the pole cutout test, as described in Part 6, the first time the climbers are used each week. If at any time during use the employee thinks the condition of the climbers may have changed, the climbers shall be reinspected and **if there is any question that the gaffs are in good condition, check them with the pole cutout test.** Climbers which do not pass this test, even after honing are considered defective and must not be used. They should be replaced in accordance with local procedures.

5.02 The employee's supervisor shall make an inspection of the climbers at intervals of not more than 3 months.

Page 6

5.03 The important conditions to look for when inspecting climbers are as follows:

- (a) Fractured gaff or hairline crack, particularly on the inner surface (bottom) of the gaff and the cutting edges
- (b) Loose gaff
- (c) Broken or loose stirrup ring loop
- (d) Fractured leg iron or start of fracture particularly on the leg side of the shank at the top of the taper below the sleeve and the gaff attachment area
- (e) Nicks and depression in gaff due to impact with a hard object
- (f) Ridge of gaff not straight

Lineman's Leg Climbers

ISS 4, SECTION 081-730-101



Fig. 9—Climber Strapped to Leg

- (g) Dull gaff beyond restoration by means of honing
- (h) Broken or distorted gaff point
- (i) Straps worn through one layer of fabric or with cuts or enlarged buckle holes that would affect the strength
- (j) Broken, severely rusted, or otherwise defective strap buckle or split steel ring
- (k) Fractured sleeve or start of fracture
- (l) Broken or loose sleeve strap loop
- (m) Broken or loose rivets on straps or pads
- (n) Broken or torn loop on strap or pad
- (o) Plastic missing from gaff guard
- (p) Loose sleeve fastener.

5.04 ♦If any of the conditions, 5.03(a) to (h) inclusive, are found, or if the condition of the climber is such that there is good cause to doubt its safety, it shall not be used but shall be

exchanged for climbers in good condition. If any of the conditions (i) to (o) are found, the item should be replaced. If condition (p) is found, the setscrew should be tightened or replaced, or the sleeve replaced.♦

5.05 Figure 10 illustrates the surfaces, ridge, and point of a properly shaped gaff. **The ridge of the gaff is straight.** Note that the point of the gaff is rounded to meet the ridge.

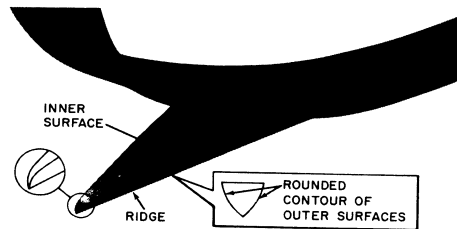

Fig. 10—Gaff Profile and Point

5.06 Figures 11 and 12 show two of the principal causes of climber cutout due to unsatisfactory gaff conditions. A dull point or dull cutting edges results in insufficient gaff penetration as shown in Fig. 11 causing the resultant cutout. If the straight ridge of the gaff is altered as indicated in Fig. 12, a prying action is produced that will cause climber cutout. Under no circumstances should any part of the gaff be altered by filing. Proper field maintenance of factory shaped gaffs is described in Part 7.



Fig. 11—Dull Gaff

Page 7

Lineman's Leg Climbers

SECTION 081-730-101

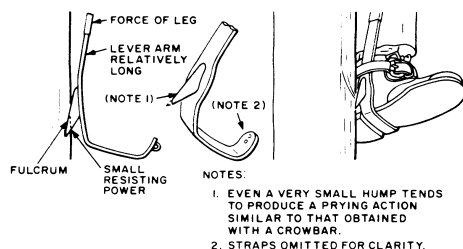

Fig. 12—Gaff Ridge and Point Altered

6. TESTING CLIMBER GAFFS

6.01 Climber gaffs shall be tested when received and thereafter any time there is any doubt as to their sharpness and the first time they are used each week. They shall be tested by making the pole cutout test as follows:

- (1) Place the climber on the leg and fasten the foot strap in the usual manner. Do not fasten the leg strap.
- (2) Remove the gaff guard and put on your gloves. Place your hand between your leg and the climber pad, palm facing the pole. Place the other hand around the pole to balance yourself. With your leg at about a 30 degree angle, the normal climbing angle, aim the gaff toward the center of the pole about one foot above the ground line. Lightly jab the gaff in the pole, so that it penetrates the wood about 1/4 inch, see Fig. 13. Do this at a location where the pole is free of cuts and knots.
- (3) Keeping just enough pressure on the stirrup to keep the gaff in the pole, but not so much as to cause the gaff to penetrate any deeper, push the climber and your hand toward the pole by moving your knee until the strap loop of sleeve is against the pole as shown in Fig. 14.
- (4) Making certain the strap loop is held against the pole with pressure from your leg, **gradually** exert full pressure straight down on the stirrup without raising your other foot



Fig. 13—Jabbing Gaff in Pole

off the ground, so as to maintain balance if the gaff does not hold.

- (5) A gaff, which is correctly shaped and is sharp, will cut into the pole and hold in a distance of 2 inches or less. Measure the cut

Lineman's Leg Climbers

ISS 4, SECTION 081-730-101



Fig. 14—Climber Holding

from point the gaff enters the pole to bottom of cut at surface of pole as indicated in Fig. 15. A gaff that is correctly shaped but dull or burred will cut in and hold but the length of the cut will be more than 2 inches. A convenient tool for measuring the length of a cut is the gaff guard. The clasp portion of the gaff guard is 2 inches long and can readily be used as a

measuring device. A gaff, which is very dull or deformed in some way, will cut out of the pole or plow through the wood for a distance greater than 2 inches. **Do not use climbers that cut out or plow through the wood for a distance greater than 2 inches.** If the climber gaff is dull, sharpen with a hone, as described in part 7 and repeat cutout test. If climbers still do not pass the pole cutout test, they are defective and should be replaced.

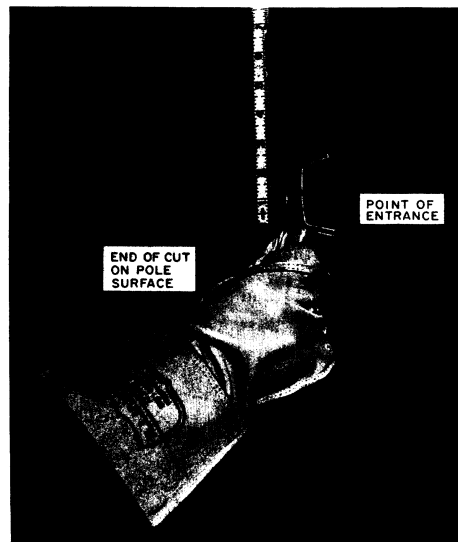

Fig. 15—Measuring Gaff Cut

7. FIELD MAINTENANCE

CLIMBER GAFFS

7.01 During normal use of climbers the edges along inner surface (cutting edges), Fig. 16, may become dull. The honing stone should be used to maintain sharp edges. Remember that even a dull gaff can cut your finger so hone carefully.

Page 9

Lineman's Leg Climbers

SECTION 081-730-101



Fig. 16—Gaff Cutting Edges

7.02 In honing, use a standard honing stone. Keep the stone well oiled with light machine oil while honing to prevent clogging the stone.

7.03 First, if there are any small burrs along the cutting edges, remove them by holding the hone against the side of the gaff and **carefully following the edge around to the tip** as indicated in Fig. 17 and 18.

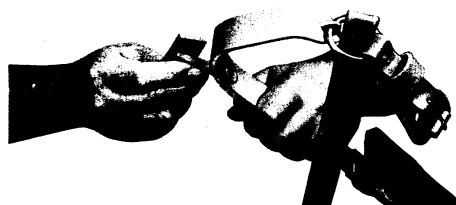

Fig. 17—Removing Burrs From Top Cutting Edge

7.04hone the inner surface of the gaff by starting the stroke near the leg iron and continue over the rounded curve of the tip as indicated in Fig. 19. Stop the honing stroke before the stone slides off the end of the gaff to prevent dulling the tip. About 20 to 25 strokes of the honing stone should be enough. **Do not attempt to reshape the tip of the gaff.**

Page 10



Fig. 18—Removing Burrs From Bottom Cutting Edge

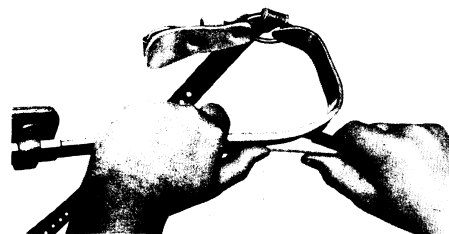

Fig. 19—Honing Inner Surface

7.05 Discard the honing stone when its surface becomes covered with grooves due to use. A badly worn hone or one with grooves will round-off the gaff cutting edges, thus causing climbers to fail the pole cutout test. The life of the hone can be extended by switching ends and sides.

7.06 When using a vise to hold a climber, always protect the leg iron by placing wood blocks between the vise jaws and the leg irons as shown in Fig. 20. This prevents scoring the leg iron which may weaken it.

Lineman's Leg Climbers

ISS 4, SECTION 081-730-101

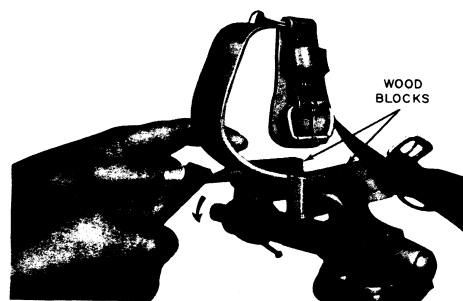

Fig. 20—Using Vise for Honing Gaffs



Fig. 21—Gaff Sharpened to Minimum Length

7.07 When climbers require sharpening and the desired sharpness to pass the cutout test cannot be obtained by honing (7.02 through 7.05), the employee should exchange them for a pair of factory sharpened climbers. Remove the E climber foot strap (2.10), the B climber straps (2.11), pads, and sleeves and equip the climbers to be returned with gaff guards. Permanently attached foot straps should remain on the returned climbers. The solid ring will then be replaced with a split ring. Tape or otherwise tie them together. Figure 21 illustrates a climber that has been machine sharpened a number of times to the *minimum length that shall be used*.

PADS

7.08 Pads should be maintained clean and pliable for maximum comfort. Maintain this condition, by using saddle soap or neats-foot oil about every 3 months as follows:

(a) Clean with a damp sponge using a neutral hand soap.

(b) With sponge and clean water, work up a lather using a good grade of saddle soap. Work lather well into pad and put in shade to dry. When lather is almost dry, rub the leather vigorously with a soft cloth.

(c) About every 6 months instead of dressing with saddle soap as in (b), clean as in (a), then while leather is still damp apply about 1/2 teaspoon of neats-foot oil on the loop side of the pad, apply oil gradually with hands using long light strokes to work into leather. After oiling allow pads to dry overnight then rub vigorously with a soft cloth to remove excess oil.

Page 11
11 Pages

Longley–Rice Radio Path Loss Analysis

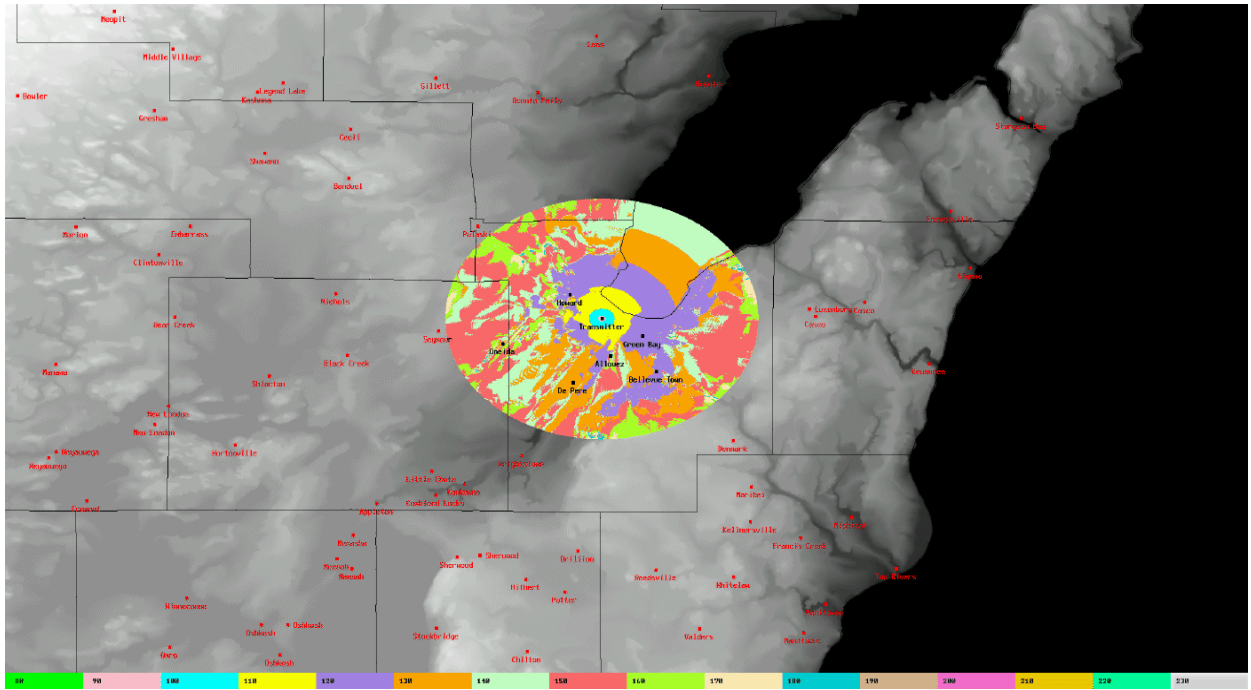

Overview

In 1967, several very smart people released a paper called Transmission Loss Predictions for Tropospheric Communication Circuits. It was a major attempt to estimate radio path losses based on *real-world* path geometries, ground conditions, atmospheric refractivity and other location-specific environmental characteristics.

This was very useful in predicting the actual coverage of TV and FM broadcast stations and for the then expanding two-way radio business.

Most people should already be familiar with the standard free-space path loss equation (in Perl):

```
# Free-Space Loss (dB)           Frequency (MHz)           Distance (kilometers)
$free_space_loss = 32.447782 + (20 * (log10 $freq)) + (20 * (log10 $distance));
```

This equation predicts radio path loss under *ideal*, isotropic conditions (i.e. nowhere on Earth). Example: two antennas operating at 2450 MHz over a distance of 5 kilometers will have an estimated path loss of 114 dB. That is, any radio signal traveling between those two antennas will be reduced by a factor of 251,188,643,151 to 1. But in a *real-world* situation, there may be significantly *more* path loss because of atmospheric refraction, poor ground conductivity, knife-edge diffraction, trees, cows, etc.

The GBPPR staff has adapted the SPLAT! (Signal Propagation, Loss, And Terrain) software program, written by John A. Magliacane, KD2BD, to provide a web based, easy-to-use interface for calculating Longley–Rice path losses for a given transmitter location just about anywhere in the United States. It will produce a high quality PNG image of the estimated Longley–Rice path loss in reference to the local ground elevation for the area.

This tool, combined with the other GBPPR microwave and link analysis tools, should be very useful in real-world plotting of wireless access point coverage, repeater coverage, radio line-of-sight, etc.

Getting Started

Point your browser to the following URL: <http://gbppr.dyndns.org:8080/longley.main.cgi>. Yes, I know, it's slower than a 2600 writer – but just live with it. You should see a nice form with all kinds of strange questions to answer or select. The first five questions are fairly self-explanatory. For the first question, enter the transmitter site's latitude in the degrees/minutes/seconds format. You are in the Northern Hemisphere, so don't enter a minus (-). The second question is for the transmitter site's longitude, also in the degrees/minutes/seconds format. You are in the Western Hemisphere, so your longitude is negative, *but don't enter the minus (-) sign*, as it's automatically taken care of in the program.

In the third question, you should enter the antenna height at the transmitter site. This is measured Above Ground Level (AGL). This means that if your antenna is on a 20 foot pole in your backyard, you'd enter 20 feet. The program will automatically calculate the ground elevation Above Mean Sea Level (AMSL) (i.e. zero elevation). You should ideally measure the antenna height to the center of the antenna's main radiating element (center-of-radiation). This height is measured from the ground to the middle of an omni-directional antenna or to the feed element on a parabolic dish.

The fourth question is for the highest transmitted frequency in megahertz (MHz). Don't mix up megahertz (MHz) and gigahertz (GHz)! For 802.11b setups, the frequency range is between 2402 and 2483 MHz.

The fifth question is for the transmitter and receiver's antenna polarization. You can only select horizontal or vertical polarization at the moment. If your antenna's main radiating element is *parallel* to the ground, it is *horizontally* polarized. If it's perpendicular to the ground, it is *vertically* polarized.

The sixth question is for the antenna height (AGL) at the receiver site. The same rules apply as at the transmitter site's antenna location.

The seventh question is for the ground dielectric constant (also called relative permittivity) of the general location. This should be a compromise between both the transmitter and receiver location's ground type. A chart is provided below which shows the approximate dielectric constants for various locations around the United States. For the vast majority of urban, small city locations use a dielectric constant of 5.

Dielectric Constants for Common Types of Earth

Surface Type	Typical Area(s)	Dielectric Constant (Relative Permittivity)
Salt Water	Oceans	81
Fresh Water	Lakes, Ponds	80
Pastoral, Low Hills, Rich Soil	Dallas, TX to Lincoln, NE	25
Pastoral, Medium Hills, Rich Soil	OH and IL	14
Flat Country, Marshy, Densely Wooded	LA near Mississippi River	12
Pastoral, Medium Hills & Forestation	MD, PA, NY, Exclusive of Mountains & Coastline	13
Pastoral, Medium Hills & Forestation, Heavy Clay Soil	Central VA	15
Rocky Soil, Steep Hills	Mountainous	2–4
Sandy, Dry, Flat, Coastal	Desert	10
Cities, Industrial Areas	Small Cities, Urban	5
Cities, Heavy Industrial Areas, High Buildings	Large Cities	3

The eighth question is for ground conductivity measured in Siemens-per-meter (S/m). A map is provided below which shows the soil conductivity around the United States. It should be noted that the map shows the conductivity in *milliSiemens-per-meter (mS/m)*. You'll need to manually adjust this to the correct format of *Siemens-per-meter*. Example: 5 mS/m is 0.005 S/m. Use 0.005 S/m (average ground) if you're too fucking stupid to read a map.

Ground Conductivity in the United States

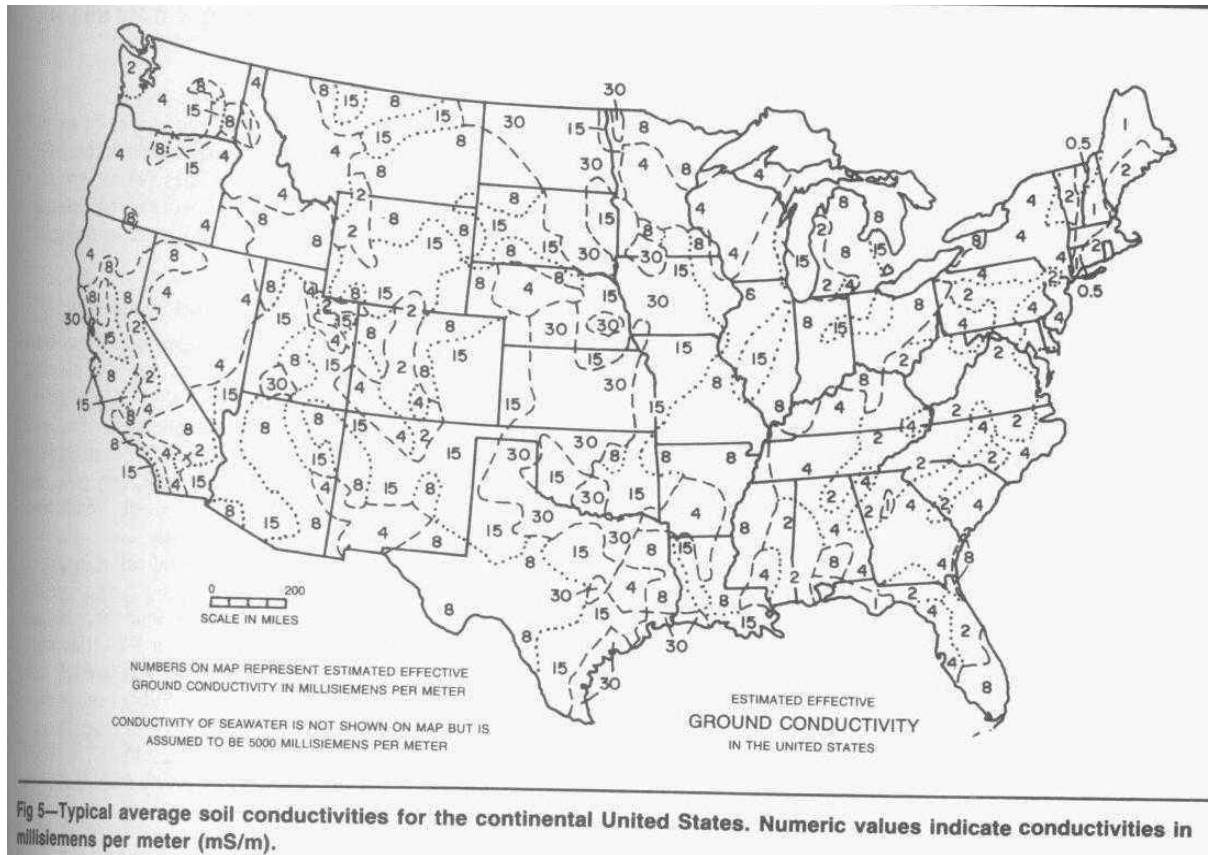

The ninth question is for the effective Earth radius, also called the *K Factor*. This is a "factor" which is used to correct for atmospheric refractivity of electromagnetic (radio) waves. Basically, radio waves don't *actually* travel in straight lines (like you read on Slashdot), they "bend" slightly to follow the Earth's curve. It's a pretty involved process to calculate this bend factor exactly, so just use the 4/3 K Factor for now.

The tenth selection may be the most confusing, the selection for the local climate type. This is a rough indication of the local meteorological conditions for the general area. We're going to have to cheat a little bit on this one. Here is a Vigants–Barnett Climate Factor map for the United States:

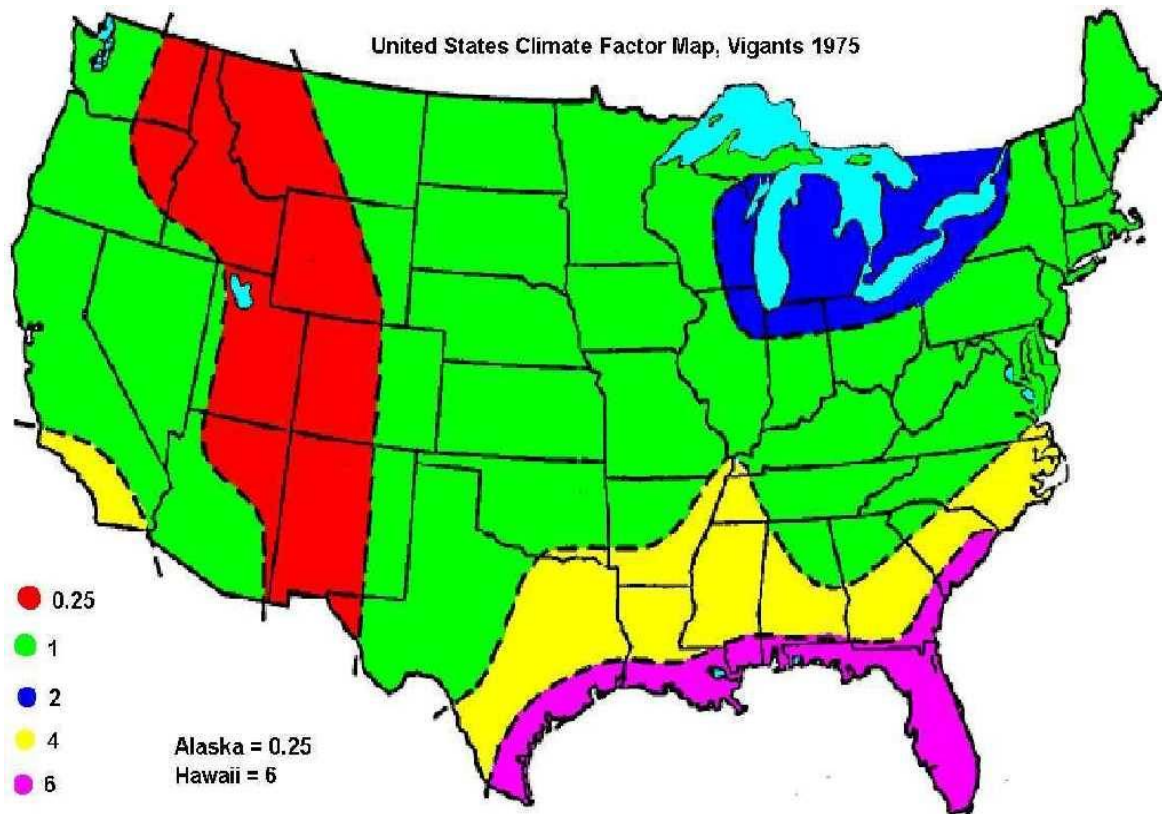

Now, this map is for a completely different set of equations, but the overall climate types are fairly similar. Locate your location on the map and then use the following key:

- **Red (0.25)** Mountainous, very rough, very dry but non-reflective.
 - ◆ Use the climate type: **Desert**
- **Green (1.0)** Average terrain, with some roughness.
 - ◆ Use the climate type: **Continental Temperate**
- **Blue (2.0)** Great lakes area.
 - ◆ Use the climate type: **Maritime Temperate, Overland**
- **Yellow (4.0)** Very smooth terrain, over water or flat desert, non-coastal.
 - ◆ Use the climate type: **Maritime Temperate, Oversea**
- **Violet (6.0)** Very smooth terrain, over water or flat desert, coastal.
 - ◆ Use the climate type: **Continental Subtropical**

If you are unsure about your location, use the climate type: **Continental Temperate**. The various maritime and subtropical climates depend on the amount of salt water in the air or surface. You may want to do your own research on that for your specific region.

The eleventh and twelfth selections are for the confidence and time variabilities. The default is set for a 50% confidence that reception will be received 90% of the time. This is the standard for mobile and two-way radio setups. Systems using digital transmissions may wish to select a 90% confidence and 90% time variability.

The three final miscellaneous questions are for the general specifications of the produced coverage plot image. The state selection allows city names and county boundaries to be drawn on the plot. The coverage radius selection allows you to reduce the coverage plot, which increases the plotting speed significantly. The final selection chooses the quality of the final output coverage plot. Select *Low / Fast* to produce a crappy JPEG image or *High / Slow* to produce a high quality PNG image. Obviously, the higher quality image will take longer to produce and download. Select the lower quality image to get a general idea of the coverage area, then switch to the higher quality setting when everything looks O.K.

Results

After double checking your data, it's time to press the *Submit* button. After what will seem like an eternity, you *should* see a picture that looks like something shown at the beginning of this article. It *will* take awhile. The program is very CPU intensive and my computer is *very* slow. Don't hit *Stop* or anything while it's computing or I'll hunt you down and beat you like a Democrat.

The script will output what parameters you entered and when finished will show the Height Above Average Terrain (HAAT) for the transmitter site and the standard FCC Part 73.313(d) azimuths.

Below that is the actual Longley–Rice Path Loss Analysis coverage plot image. It may be quite large, so adjust your browser accordingly. The rainbow of colors represent path losses in 10 dB increments. The color key is shown below:

Path Loss Color Key

80 dB	90 dB	100 dB	110 dB	120 dB	130 dB	140 dB	150 dB
160 dB	170 dB	180 dB	190 dB	200 dB	210 dB	220 dB	230 dB

When looking at the coverage plot output, the GREEN color represents approximately 80 dB loss, the PINK is 90 dB loss, the CYAN is 100 dB loss, etc.

Is it Good or is it Wack?

Now that you have the estimated path losses for a 360° coverage area from your transmitter site, you can (somewhat) accurately predict the received power level (in dBm) at any receiver location.

Say your transmitter is putting out +36 dBm (4 Watts) Effective Isotropic Radiated Power (EIRP) and your receiver has a threshold (sensitivity) of -90 dBm (7 microvolts). In any location in the 80, 90, 100, 110, 120 and 130 dB Longley–Rice path loss zones, you should be able to establish a wireless link (provided the receiver is using a 0 dB gain antenna and no feedline losses). That was determined by taking the EIRP (in dBm) and subtracting the path loss, then adding the receiver antenna gain (minus feedline loss) and comparing it to the receiver threshold level.

Example:

1. Transmitter EIRP is +28 dBm (630 mW).
2. Longley–Rice path loss to your receiver location is 140 dB.
3. Receiver antenna gain is 24 dB with 6 dB feedline loss, for an overall receiver gain of 18 dB.
4. Receiver threshold is –90 dBm (7 microvolts).
5. $(28 - 140) + 18 = -94$
6. Approximate received power level at the receiver location will be –94 dBm. A wireless link would be possible (barely) and with a 4 dB fade margin.

Now, this is under ideal conditions. The program doesn't take into account man–made objects or foliage blocking the path – which will *really* kill a wireless signal in the microwave bands.

An interactive CGI script to determine EIRP (and K factor) is available at:

<http://gbppr.dyndns.org:8080/wireless.super.main.cgi>. This is the GBPPR Wireless Network Link Analysis – Super Edition script which will calculate a whole bunch of variables. It may be hard to figure out at first, so play around with it and if you're still having trouble you can email me. Determining the receiver's threshold may be difficult, so ask the manufacture if you have any questions on that.

Notes

You may download the original Technical Note 101 – Transmission Loss Predictions for Tropospheric Communication Circuits, at the following website:

<http://its.bldrdoc.gov/pub/ntia-rpt/tn101>

A point–to–point microwave radio path analysis utility is available at:

<http://gbppr.dyndns.org:8080/path.main.cgi>

Additional interactive wireless / RF design utilities may be accessed at the main GBPPR website:

<http://www.gbppr.org>

DMS-100 EXPIRED_PASSWORD_GRACE

Table OFCENG, Parameter EXPIRED_PASSWORD_GRACE

Functional Description of Parameter EXPIRED_PASSWORD_GRACE

This parameter appears only if ENHANCED_PASSWORD_CONTROL in table OFCOPT is set to Y (yes).

It specifies the number of logons for which a password may be used if the password is older than the value of parameter PASSWORD_LIFETIME. If this feature is not required, set this parameter to the maximum value (32767 logons).

Range Information

Minimum	Maximum	Default
1	32767	3

Activation

Immediate

Dependencies

Not applicable

Consequences

Not applicable

Verification

Not applicable

Memory Requirements

This parameter has no memory impact.

Dump and Restore Rules

Copy the existing value of this parameter, unless it is an extension and the operating company has specifically requested a change to the value of this parameter.

DMS-100 MIN_PASSWORD_LENGTH

Table OFCENG, Parameter MIN_PASSWORD_LENGTH

Functional Description of Parameter MIN_PASSWORD_LENGTH

This parameter specifies the minimum number of characters that are allowed for logon passwords.

Provisioning Rules

Specify the minimum number of characters that are allowed for logon passwords.

Range Information

Minimum	Maximum	Default
1	16	6

Activation

Immediate

Dependencies

This parameter appears only if the switching unit has parameter ENHANCED_PASSWORD_CONTROL in table OFCOPT set to Y (yes) and the software package NTX000AA.

Consequences

Not applicable

Verification

Not applicable

Memory Requirements

This parameter has no memory impact.

Dump and Restore Rules

Copy the existing value of this parameter, unless the operating company has specifically requested a change to the value of this parameter.

DMS-100 PASSWORD_LIFETIME

Table OFCENG, Parameter PASSWORD_LIFETIME

Functional Description of Parameter PASSWORD_LIFETIME

This parameter determines the duration, in number of days, for which a password may be used.

Provisioning Rules

The interval is timed from the date of the last password change for the corresponding user identification. If this feature is not required, set the parameter to the maximum value (32767 days).

Range Information

Minimum	Maximum	Default
1	32767	30

Activation

Immediate. Expired passwords cannot be rejuvenated by changing the value of this parameter.

Dependencies

This parameter appears only if ENHANCED_PASSWORD_CONTROL in table OFCOPT set to Y (yes).

Consequences

Not applicable

Verification

Not applicable

Memory Requirements

This parameter has no memory impact.

Dump and Restore Rules

Copy the existing value of this parameter, unless it is an extension and the operating company has specifically requested a change to the value of this parameter.

Use Old Cellular Phones to Jam Tape Recorders



Overview

This is a device to remotely cause RF interference in unshielded electronic devices (cameras, microphones, recorders, etc) by using two old "bag"-style Motorola AMPS cellular phones, in continuous transmit, via the test mode commands.

It works by the mixing of two RF carriers in the non-linear junctions contained in most semiconductor components (transistors, diodes, ICs). If you were to flood an electronic device with two signals, say 837.000 MHz and 837.001 MHz, the non-linear junctions would mix the two signals to form the cross-products of 837.000 ± 837.001 MHz and 837.001 ± 837.000 MHz. The $837.001 - 837.000$ MHz product is the one we are most interested in, as that produces an output frequency of 1 kHz (1000 Hz), which is a tone in the audio spectrum and something most electronic devices will respond to.

When pointing this "jammer" at a recording device, say a tape recorder, the recorder's output signal (to the recording tape) would be *flooded* with the 1000 Hz tone – essentially bypassing the microphone – and hopefully rendering the device useless.

Natural noise and other imperfections mean that even though the two cellular phones are programmed to transmit at the same frequency, they are never *exactly* the same frequency at the same time. They will always be within a few hundred Hertz of each other. This causes a natural "warbly" jamming signal to be produced.

Block Diagram & Schematics

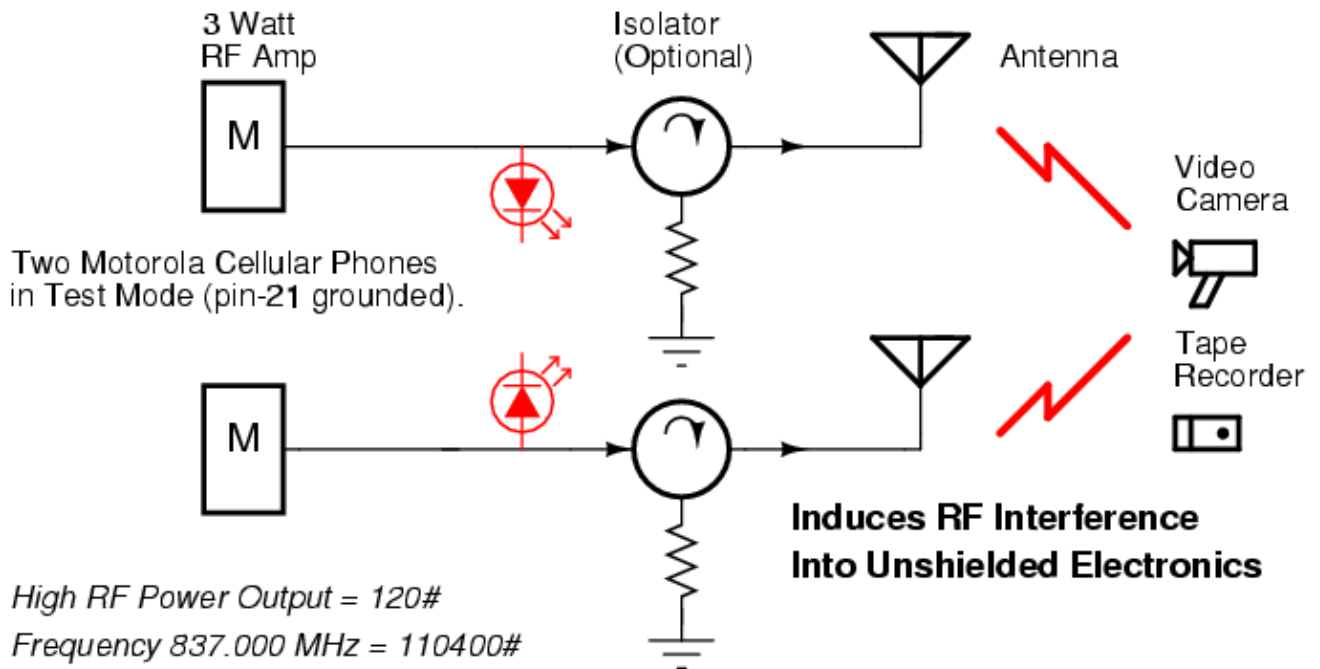

The isolators on the phone's RF output help prevent "RF feedback" from disrupting the phones themselves. These isolators are *highly* recommended, but can be difficult to find. Search hamfests for 800 MHz isolators from old cellular site installations.

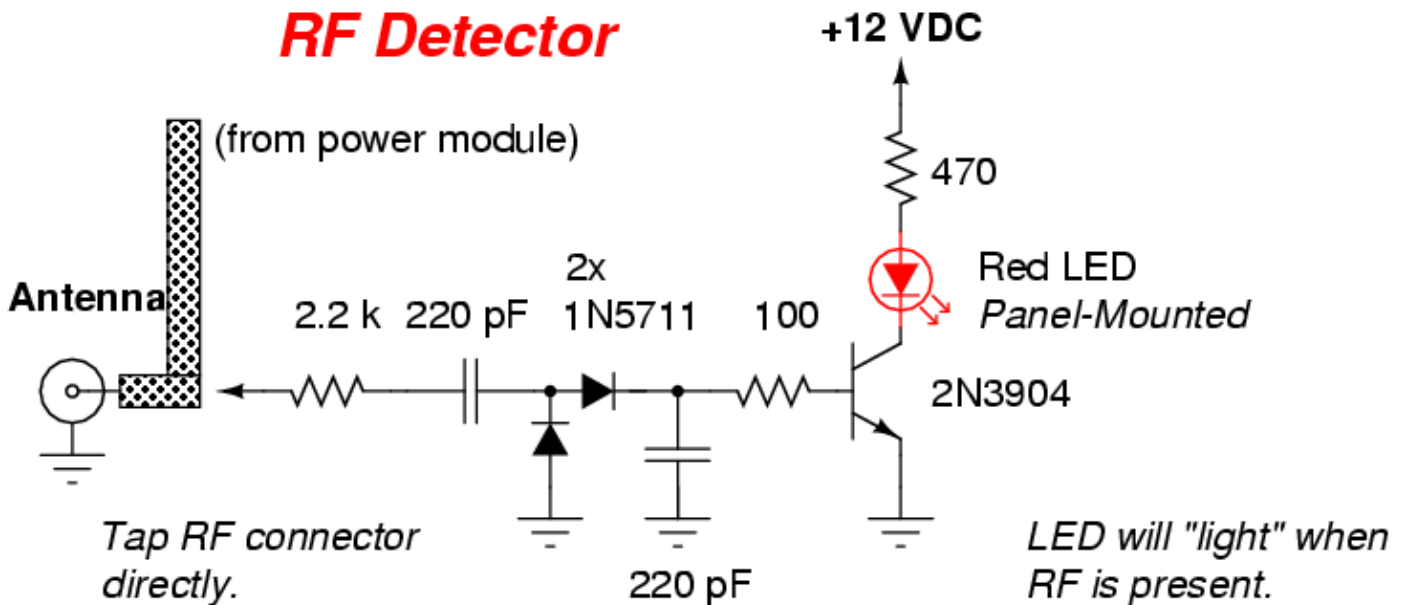

This is a little additional (and optional) circuit which will light an LED when strong RF is detected. It is useful for a quick visual verification on the phone's transmitting status. A bug with this circuit is that RF from the *other* phone can feedback into the diode detector and the LED will light anyway. The above mentioned isolators will cure this problem, or just increase the value of the tap resistor (2.2k).

Test Mode Commands

To place the older bag-style Motorola cellular phones into test mode, you'll need to ground pin-21 on the phone's DB-25 connector before powering up the phone. This is shown below:

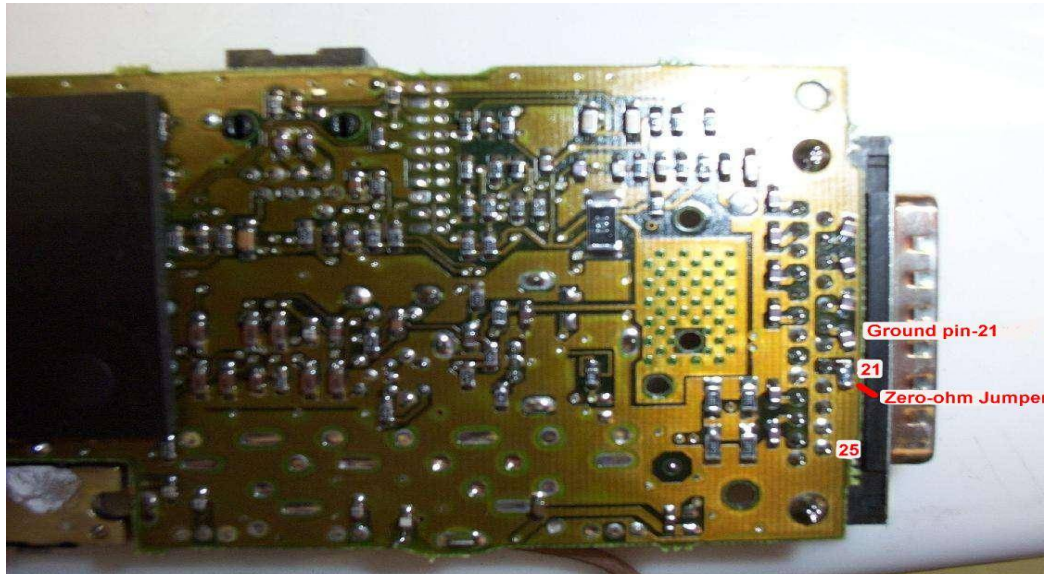

On power-up in test mode, the handset LCD screen will start flashing random numbers.

Example: **314 059**

To set the transmit frequency and RF output power level, enter the following keypad commands:

Press [#] to get to the **U5** ' prompt. This is the test mode prompt where all the commands will be entered from. (Note: the U5 stands for U.S.)

Enter the frequency you want to transmit at. This can be anything from 824.04 MHz to 848.97 MHz in 30 kHz steps. You'll need to enter the frequency in "Motorola Test Mode" channel format. This is explained further in the infamous "Motorola Bible". Example: to transmit at 837.00 MHz, cellular channel 0400, you'd enter:

[1] [1] [0] [4] [0] [0] [#]

You'll need to increase the transmitter RF output to the maximum of 3 Watts (for this particular model phone). To do this, enter: **[1] [2] [0] [#]**

To turn the transmitter RF carrier on enter: **[0] [5] [#]**

Verify with a frequency counter or communications receiver that it is indeed transmitting at 837.00 MHz.

Repeat the same steps for the second phone, but only turn the second phone's transmitter RF carrier on when you need to commence the jamming.

Pictures & Description



Picture of the DB-25 connector on the phone. The RED wire is the 12 VDC (positive) supply lead, the BLACK wire is the ground (negative). The small white/yellow wire is for the RF power output LED. The phone's mini-UHF connector was replaced with a TNC connector and an L-bracket was added for mounting. Pins 2 & 3 and 4 & 5 on the DB-25 connector *must* be tied together if you don't power the phone via the normal battery or cigarette connector.

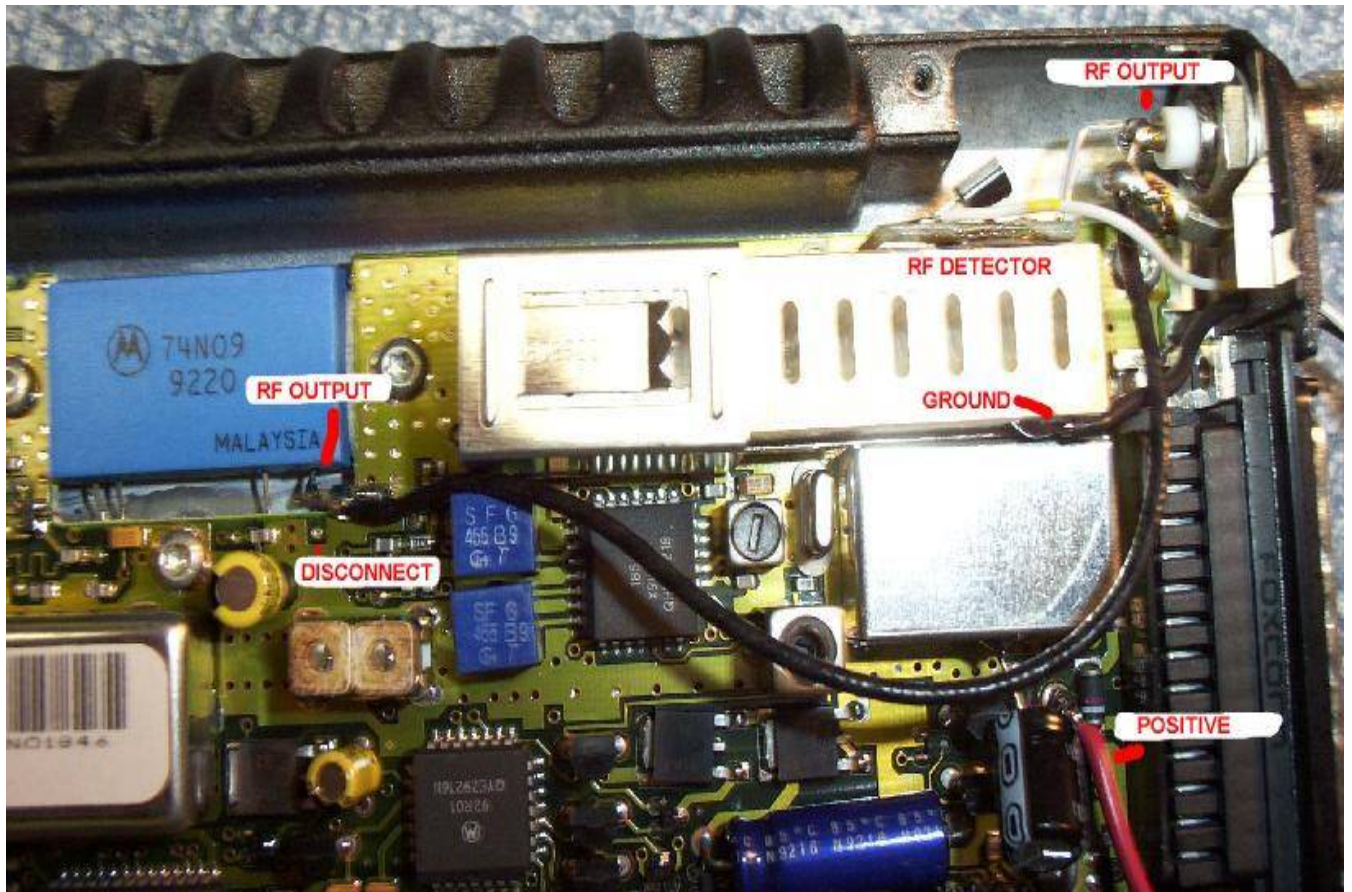

Internal phone view. RF output is tapped directly from the hybrid power module's RF output pin. This increases the output power level slightly by not having to pass through the duplex filter. This is optional. A small diode detector circuit was added for a visual indication of RF output. You can also see where the DC power supply leads are connected. The RED positive lead is soldered directly to the protection diode. The BLACK negative lead is soldered to the duplex filter. Also, a small 10 uF bypass capacitor was added from the protection diode to ground.



Outside case overview. Built into an old .30 caliber military ammo box. All holes and RF connectors are sealed with rubber washers to improve water resistance. All hardware is stainless steel. The phone's original mini-UHF connectors were salvaged and panel-mounted for use with the original antennas. The front-panel protection bars are brass drawer handles. Camouflage is the standard Western Europe green. Lord knows it's just a matter of time before those bastards kill millions of people again and I'll need to carry all my hardware there to kill, err, protect them...



Front-panel overview. The two red LEDs indicate RF output. The +12 VDC power supply is protected with a 10 amp fuse. The two phones in "high-power mode" will draw around 6 amps continuously.



Side view. Those are the phone's original, stock, unity gain, "rubber duck" antennas. They work very well for transmitting across the entire 800 MHz band.



Internal case view. Each phone is mounted via its bracket to the bottom of the ammo box. Only one handset is needed for the issuing test mode commands. The phones will still transmit even if the handset is removed.

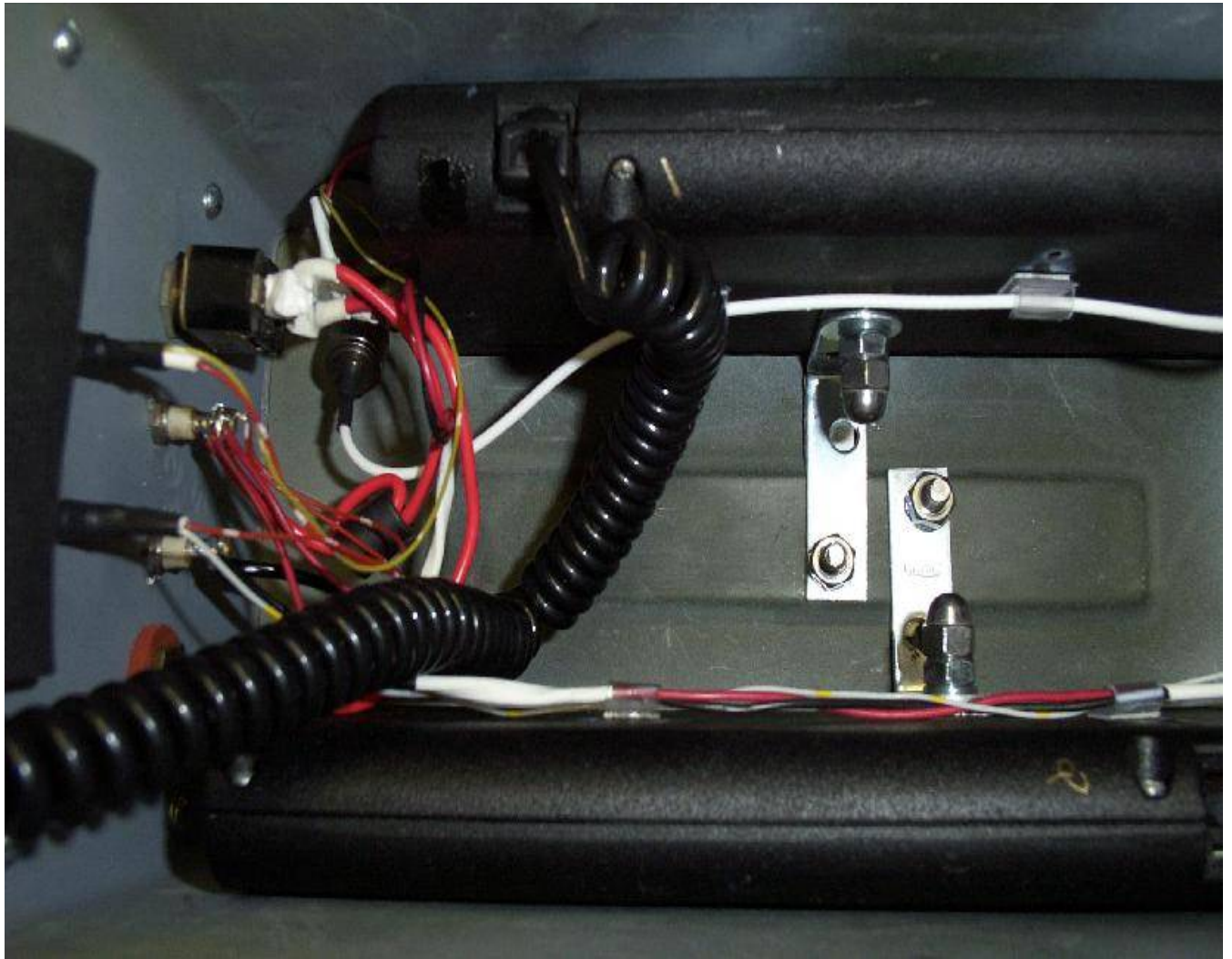

Close up internal view behind the front-panel. A piece of flexible foam (far-left) flips down to protect the exposed terminals and wires.



Handset picture. The handset is bolted to the ammo box's cover. Be sure it doesn't pinch the cable when closing. A large CIA logo is underneath the handset.



Testing setup. The green ammo box on the left is a large 12 volt lead-acid battery. The jammer is in the middle and the "victim" tape recorder is on the right. The effective jamming radius of this setup was only about a meter. More RF power output and/or directional antennas will increase the range.



Jammer in operation. I was hoping it would "jam" the digital camera's picture, but alas it only interfered with the camera's LCD screen. The picture came out fine – but doesn't appear as sharp.

Notes

Other projects developed by GBPPR's Directorate of Science & Technology are available at:

<http://www.dafh.org/gbppr/mil/index.html>

The Motorola Bible v3.0, by Mike Larsen is available at:

<http://www.dafh.org/gbppr/mil/cellbug/motorola.txt>

Bonus

 Wisconsin Bell
AN AMERITECH COMPANY

Defective Plug-In Units

M6875
(3-88)

Ship To: Wisconsin Bell Central Stock
4444 Ameritech Drive
South Bend, Indiana 46628

Type of Equipment: _____

Shipping Notice or P.I.E. Order No.: _____

Date: _____ Trouble Observed: _____

_____ Trouble Observed By: _____

Location: _____

End of Issue #4



Any Questions?

Editorial and Rants

The truth. Is it that fucking hard to tell? Here's some *facts* you won't read in 2600!

"One way or the other, we are determined to deny Iraq the capacity to develop weapons of mass destruction and the missiles to deliver them. That is our bottom line." – President Clinton, Feb. 4, 1998

"If Saddam rejects peace and we have to use force, our purpose is clear. We want to seriously diminish the threat posed by Iraq's weapons of mass destruction program." – President Clinton, Feb. 17, 1998

"Iraq is a long way from [here], but what happens there matters a great deal here. For the risks that the leaders of a rogue state will use nuclear, chemical or biological weapons against us or our allies is the greatest security threat we face." – Madeline Albright, Feb 18, 1998

"He will use those weapons of mass destruction again, as he has ten times since 1983." – Sandy Berger, Clinton National Security Adviser, Feb, 18, 1998

"[W]e urge you, after consulting with Congress, and consistent with the U.S. Constitution and laws, to take necessary actions (including, if appropriate, air and missile strikes on suspect Iraqi sites) to respond effectively to the threat posed by Iraq's refusal to end its weapons of mass destruction programs." – Letter to President Clinton, signed by Sens. Carl Levin, Tom Daschle, John Kerry, and others Oct. 9, 1998

"Saddam Hussein has been engaged in the development of weapons of mass destruction technology which is a threat to countries in the region and he has made a mockery of the weapons inspection process." – Rep. Nancy Pelosi (D, CA), Dec. 16, 1998

"Hussein has .. chosen to spend his money on building weapons of mass destruction and palaces for his cronies." – Madeline Albright, Clinton Secretary of State, Nov. 10, 1999

"There is no doubt that ... Saddam Hussein has invigorated his weapons programs. Reports indicate that biological, chemical and nuclear programs continue apace and may be back to pre–Gulf War status. In addition, Saddam continues to redefine delivery systems and is doubtless using the cover of a licit missile program to develop longer–range missiles that will threaten the United States and our allies." – Letter to President Bush, Signed by Sen. Bob Graham (D, FL,) and others, December 5, 2001

"We begin with the common belief that Saddam Hussein is a tyrant and a threat to the peace and stability of the region. He has ignored the mandated of the United Nations and is building weapons of mass destruction and the means of delivering them." – Sen. Carl Levin (D, MI), Sept. 19, 2002

"We know that he has stored secret supplies of biological and chemical weapons throughout his country." – Al Gore, Sept. 23, 2002

"Iraq's search for weapons of mass destruction has proven impossible to deter and we should assume that it will continue for as long as Saddam is in power." – Al Gore, Sept. 23, 2002

"We have known for many years that Saddam Hussein is seeking and developing weapons of mass destruction." – Sen. Ted Kennedy (D, MA), Sept. 27, 2002

"The last UN weapons inspectors left Iraq in October of 1998. We are confident that Saddam Hussein retains some stockpiles of chemical and biological weapons, and that he has since embarked on a crash course to build up his chemical and biological warfare capabilities. Intelligence reports indicate that he is seeking nuclear weapons..." – Sen. Robert Byrd (D, WV), Oct. 3, 2002

"I will be voting to give the President of the United States the authority to use force— if necessary— to disarm Saddam Hussein because I believe that a deadly arsenal of weapons of mass destruction in his hands is a real and grave threat to our security." – Sen. John F. Kerry (D, MA), Oct. 9, 2002

"There is unmistakable evidence that Saddam Hussein is working aggressively to develop nuclear weapons and will likely have nuclear weapons within the next five years ... We also should remember we have always underestimated the progress Saddam has made in development of weapons of mass destruction." – Sen. Jay Rockefeller (D, WV), Oct 10, 2002

"He has systematically violated, over the course of the past 11 years, every significant UN resolution that has demanded that he disarm and destroy his chemical and biological weapons, and any nuclear capacity. This he has refused to do" – Rep. Henry Waxman (D, CA), Oct. 10, 2002

"In the four years since the inspectors left, intelligence reports show that Saddam Hussein has worked to rebuild his chemical and biological weapons stock, his missile delivery capability, and his nuclear program. He has also given aid, comfort, and sanctuary to terrorists, including al Qaeda members. It is clear, however, that if left unchecked, Saddam Hussein will continue to increase his capacity to wage biological and chemical warfare, and will keep trying to develop nuclear weapons." – Sen. Hillary Clinton (D, NY), Oct 10, 2002

"We are in possession of what I think to be compelling evidence that Saddam Hussein has, and has had for a number of years, a developing capacity for the production and storage of weapons of mass destruction." – Sen. Bob Graham (D, FL), Dec. 8, 2002

"Without question, we need to disarm Saddam Hussein. He is a brutal, murderous dictator, leading an oppressive regime ... He presents a particularly grievous threat because he is so consistently prone to miscalculation ... And now he is miscalculating America's response to his continued deceit and his consistent grasp for weapons of mass destruction ... So the threat of Saddam Hussein with weapons of mass destruction is real..." – Sen. John F. Kerry (D, MA), Jan. 23, 2003

Iran: Germany Supplied Chemical Weapons to Iraq

By ASSOCIATED PRESS

TEHRAN, Iran

Two Iranian war invalids unveiled a plaque outside the German Embassy in Tehran on Friday that accuses Germany of supplying chemical weapons to Iraq during the Iran–Iraq war of 1980–88.

The plaque's erection was clearly in retaliation for the unveiling of a plaque in Berlin last month that marked the assassination of four Iranian Kurdish dissidents in 1992. The Berlin plaque, erected by the local authority at the site of the former Mykonos restaurant, blamed the then Iranian government for the killings.

One of the two veterans who unveiled the plaque, Ahmad Paryab, who spoke with plastic pipes running into his nose to assist breathing, called for the prosecution of Germany's top officials during the Iran–Iraq war.

"We demand that the then leaders of Germany be tried in an international court for war crimes and that the German government pay compensation to us," Paryab told about 100 people who attended the ceremony. Paryab was wounded by chemical weapons in the war, as were other members of the crowd.

The metal plaque stands on a four–meter(yard)–high plinth, clad in gray marble, in the sidewalk opposite the embassy's consular entrance on Ferdowsi Street in central Tehran.

It bears texts in Farsi and English, but the English is a poor translation of the original. It reads: "Name of the German government for the Iranian nation is the reminder of the great catastrophe of chemical massacre during the Iraqi Baathist regime's imposed war against Iran."

The Associated Press translated the Farsi inscription as: "The name 'German government' is a reminder to the Iranian nation of the catastrophe of chemical massacres during the war provoked by Iraqi Baathist regime against Iran."

The Tehran local authorities erected the plaque and a tent next to it, which houses a temporary exhibition of photographs of victims of chemical attacks during the war. The pictures show wounded Iranian children as well as soldiers.

The head of the Tehran City Council, Mahdi Chamran, said the plaque was put up to "defend the rights of chemical victims."

"The world has not forgotten the crimes committed by Hitler during World War II. And it should not forget this crime as well," he told reporters.

During the ceremony, the crowd heard that war veteran Ghodrattollah Darabi had died Thursday after a long battle against the effects of chemical attacks.

While Iranian officials do not say openly that their plaque is in retaliation for the one in Berlin, they condemn the Berlin plaque when they speak of the Tehran memorial.

Chamran condemned the Berlin memorial, saying Friday: "It was an ugly move."

The day after the Berlin plaque's unveiling on April 20, the Iranian Foreign Ministry summoned the German ambassador and protested it. The plaque's inscription blames the assassination on "those in power in Iran at the time."

A German court found in 1997 that the Iranian authorities had ordered the killing of the four Iranian Kurds. Iran denied any involvement.

In Germany on Friday, government officials said the German ambassador to Tehran had sent a letter to the associations of Iranian victims of Iraqi chemical attacks, expressing sorrow for their plight but rejecting any German government responsibility.

German officials, who spoke on condition of anonymity, said the letter notes that a number of German business executives were tried and convicted of illegally supplying equipment to Iraq in the 1980s.



Death to Europe