

**AT&T**

**CLASSIC MAIL™**  
VOICE MESSAGING SYSTEM

**Mailbox  
User  
Guide**

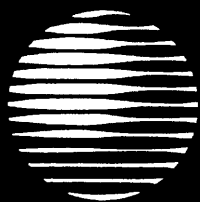

**AT&T**

**CLASSIC MAIL™**  
VOICE MESSAGING SYSTEM

**Mailbox  
User  
Guide**

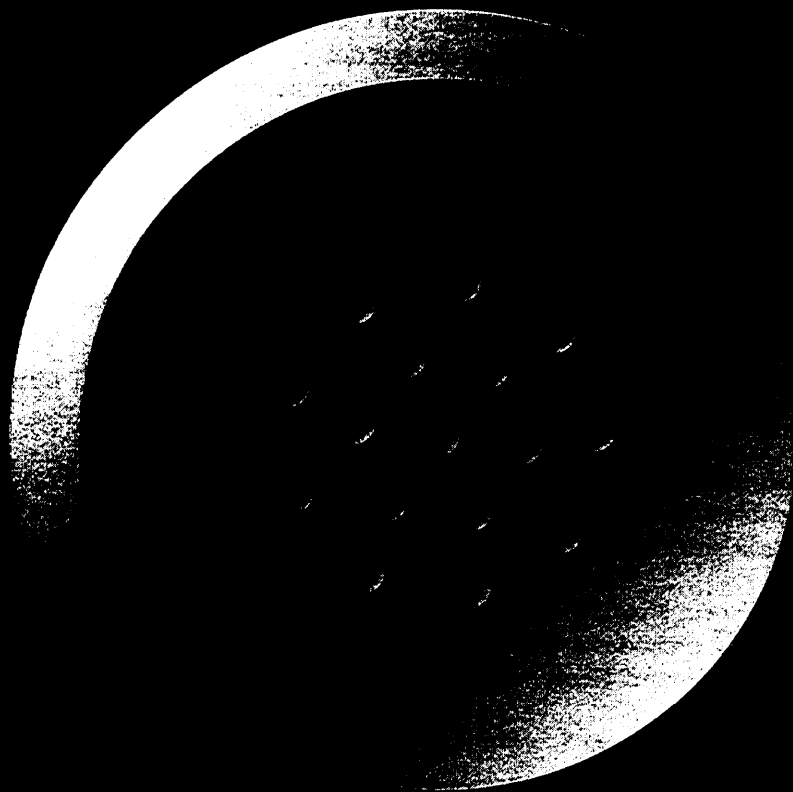

## **Notice**

Every effort was made to ensure that the information in this book was complete and accurate at the time of printing. However, information is subject to change.

## **Federal Communications Commission (FCC) Interference Notice**

This equipment has been tested and found to comply with the limits for a Class A digital device, pursuant to Part 15 of the FCC rules. These limits are designed to provide reasonable protection against harmful interference when equipment is operated in a commercial environment. This equipment generates, uses and can radiate radio frequency energy and, if no installed and used in accordance with the instruction manual, may cause harmful interference to radio communications. Operation of this equipment in a residential area is likely to cause harmful interference in which case the user will be required to correct the interference at their own expense.

## **Security**

As a customer of new telecommunications equipment, you should be aware of the significant and growing problem of theft of long distance services by third parties, known commonly as “toll fraud.” It is particularly important that you understand and take appropriate steps to deal with this crime because under applicable tariffs, you will be responsible for payment of associated toll charges. AT&T cannot be responsible for such charges and will not make any allowance or give any credit resulting from toll fraud.

Toll fraud can occur despite the preventative efforts of network providers and equipment manufacturers. Toll fraud is a potential risk for any customer with telecommunications equipment having one or more of the following features: (1) remote access, (2) automated attendant, (3) voice mail, (4) remote administration and maintenance, and (5) call forwarding (remote). This is not a product or design defect, but a risk associated with equipment having one or more of the features described above. If your new telecommunications equipment possesses any of these features, please consult the relevant portion of your documentation for further details and specific procedures to reduce the risk of toll fraud or contact your AT&T dealer for further details.

## **Trademarks**

MERLIN is a registered trademark of American Telephone & Telegraph Corporation. CLASSIC MAIL is a trademark of American Telephone & Telegraph Corporation.

## **Warranty**

AT&T provides limited warranty to this product. Refer to the “AT&T Limited Warranty and Limitation of Liability” in Appendix E of the *CLASSIC MAIL System Reference Guide*.

## **Ordering Information**

The order number for this book is 585-321-101. To order additional books, call 1-800-432-6600 in the U. S., 1-800-255-1242 in Canada, and from other countries, call 1-317-322-6646 or send Fax to 1-317-322-6699.

## **Support Telephone Numbers**

In the U. S., AT&T provides a toll-free customer helpline 24 hours a day. In the U. S., call the AT&T Helpline at 1-800-628-2888 or your Authorized Dealer if you need assistance when installing, programming, or using your system.

For assistance outside the U. S., contact your local AT&T authorized representative.

# Table of Contents

<b>Preface</b>	<b>5</b>
<b>1. Before you Begin</b>	<b>7</b>
Know Your Phone	7
Commonly Used Keys	10
Know Your Mailbox	10
Getting Into the CLASSIC MAIL System	12
<b>2. Your Mailbox</b>	<b>15</b>
First-Time Use	15
Recording a Greeting	19
Switching a Greeting	21
<b>3. Your Messages</b>	<b>23</b>
Letting CLASSIC MAIL Answer Your Calls	23
Knowing when You Have Messages	23
Listening to Your Messages	26

Handling your Messages	28
Deleting and Undeleting a Message	29
Replying to a Message	30
Forwarding a Copy of a Message	32
Listening to Envelope Information	33
Sending a Message	34
Special Delivery Options	35
Group Lists	36
<b>4. Off-Site Message Alert</b>	<b>39</b>
How Off-Site Message Alert Works	39
Setting Up Off-Site Alert to a Phone	44
Setting Up Off-Site Message Alert to a Pager	45
Turning Off-Site Message Alert On or Off	46
Setting the Number of Attempts	47
Determining How Often You're Alerted	48
Reviewing the Settings for Off-Site Message Alert	49
<b>5. Transferring Calls Into the CLASSIC MAIL System</b>	<b>51</b>
Transferring Outside Callers	51
Merlin 1030/3070 Transfer Procedures for Attendants	54
Merlin 1030/3070 Transfer Procedures for Non-Attendants	57

# Preface

To streamline your telephone communication, your company has just installed a new round-the-clock voice messaging system, the CLASSIC MAIL™ Voice Messaging System. When you can't take calls, the CLASSIC MAIL system answers your phone and stores messages in your personal mailbox. You can check your messages whenever and from wherever you like. And, if you are temporarily out of your office, you can have the CLASSIC MAIL system notify you at a phone or pager number each time a new message arrives.

This booklet contains instructions for using the CLASSIC MAIL system features. It includes the following chapters:

- Chapter 1, “*Before You Begin*,” discusses what you need to know to get started using the CLASSIC MAIL system.

- Chapter 2, “*Your Mailbox*” discusses how to open and initialize your “voice mailbox. ”
- Chapter 3, “*Your Messages*” discusses how to listen to your messages.
- Chapter 4, “*Off-Site Message Alert*” discusses how to use the CLASSIC MAIL system to alert you that you have messages even when you are out of the office.
- Chapter 5, “*Transferring Calls into the CLASSIC MAIL System*” discusses how to transfer outside callers into the CLASSIC MAIL system.

Instructions on how to install the CLASSIC MAIL system are contained in a separate document, the *CLASSIC MAIL System Reference Guide*.

**Before  
You  
Begin**



# 1. Before You Begin

You probably already have many of the skills necessary to use the CLASSIC MAIL System.

## **Know Your Phone**

Using the CLASSIC MAIL system is a simple matter of using a touch-tone phone. You press various keys to gain access to your mailbox, use its functions, and move around in the system.

Before you use your mailbox, you should know that an operator or receptionist is called an *attendant* and a phone extension is called an *intercom*.

You should also know how to perform these basic phone operations:

- Answer an outside call
- Call another intercom
- Transfer an outside call

Your phone should resemble one of the phones in Figure 1A. The number and types of buttons will vary depending upon the model of phone system and the types of phone sets you have. There should be voice mail labels on the buttons similar to the one shown in Figure 1B for lines that are assigned to the CLASSIC MAIL system.

*Figure 1A: Typical Merlin telephones.*

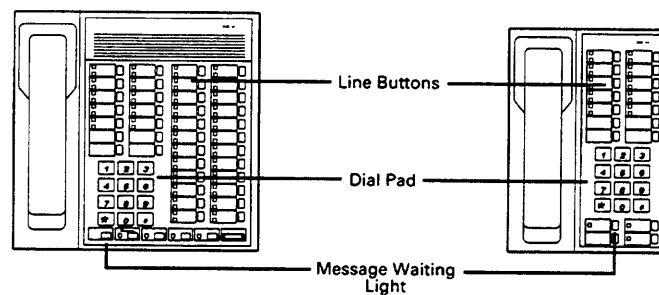

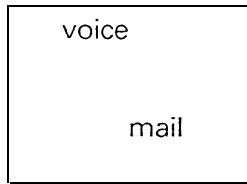

Figure 1B. Voice mail tables

No matter how many additional buttons your phone has, the dial pad and the numbered keys you press to make a call are the same on any phone. You'll use the dial pad extensively for voice messaging, so you should be familiar with the *star* the *pound* keys and with the term *enter*, which simply means “press a key or keys. ”

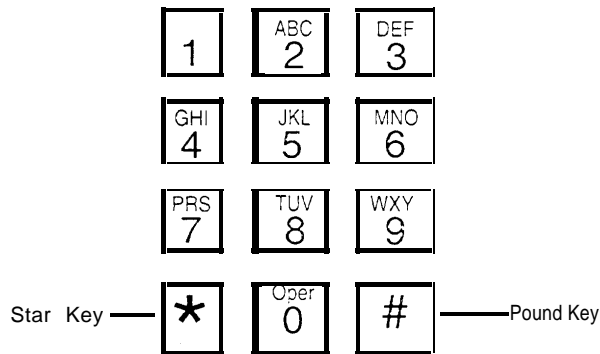

Figure 1C: Keys used for CLASSIC MAIL voice messaging functions

## Commonly Used Keys

---

There are certain keys on the dial pad that have a consistent use no matter what you're doing with voice messaging:

**	Returns you to the top-level menu
0	Transfers you to attendant
#	Accepts an entry OR gives access to company directory
*	Backs up to previous step or cancels an action

**Note:** *If you have a Merlin Plus, a Merlin 1030/3070, or a Merlin with Feature Package 2 installed, you may have to press the pound key twice to generate a tone. If you do not hear a tone when pressing your pound key, try pressing it twice.*

## Know Your Mailbox

---

A voice mailbox includes:

- A personal password which allows you to open your mailbox and check messages.
- Primary and alternate greetings that callers hear when they reach your mailbox.

- Your recorded directory name which callers hear when there is no primary or alternate greeting, or when they use the company directory.
- A mailbox number which is identical to your intercom number (if you have an intercom) or a three-digit number beginning with 9.

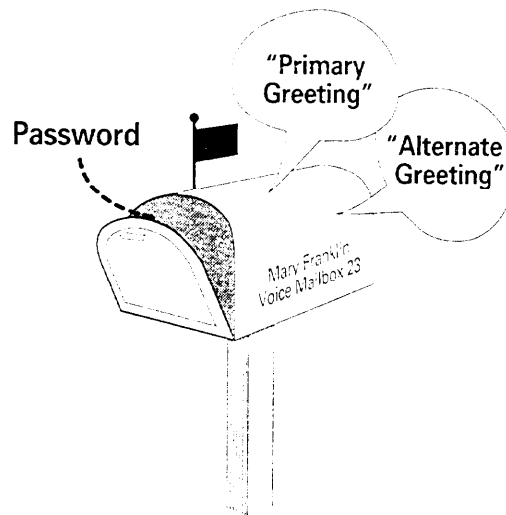

*Figure 1D: Elements of your voice mail box*

You have been assigned either a regular mailbox or a guest mailbox. If your mailbox number is from 0-79, you have a regular mailbox. If your mailbox number is from 901 to 999, you have a guest mailbox. Your mailbox is capable of storing up to 60 minutes of recorded messages, and up to 180 separate messages.

### **Getting Into the CLASSIC MAIL System**

There are several ways to reach the CLASSIC MAIL system:

- Select a CLASSIC MAIL system access line on your Merlin telephone and dial the access code (normally the star key). CLASSIC MAIL system access lines are the lines labeled as shown in Figure 1B.
- From an outside line, call your company and ask the operator to transfer you to the CLASSIC MAIL system.

- From an outside line, call your company and wait for the CLASSIC MAIL system's automated answering service to answer.

Once you gain access to the CLASSIC MAIL system, you will be instructed to press various keys on your telephone dial pad. These instructions will lead you through the use of the CLASSIC MAIL system's features. If you don't hear the instruction you expected, or if you're not sure what to do, wait and these instructions will repeat. Often these repeated instructions will contain additional information about using the CLASSIC MAIL system's features.

**Your  
Mailbox**



# 2. Your Mailbox

## **First-Time Use**

---

You must create a password the first time you open your mailbox. You will also record your name for the company directory. Finally, you should enter the first four letters of your last name into the company directory so callers who don't know your mailbox number can still leave messages in your mailbox.

### ***To open and use your mailbox the first time:***

1. Ask your manager for the CLASSIC MAIL system access code and your mailbox number.
2. Dial the access code from an available CLASSIC MAIL system line.

The top-level menu message plays.

3. Enter your mailbox number.

4. To enter the temporary password, press 0000.

Hear an instruction to enter your new password.

5. Enter a new password of four to eight digits.

6. When you are finished press **#**

Hear your password played back to you.

7. To accept the password press **#**

OR to start again, press **\***

Hear an instruction to record your name at the tone.

8. Record your name, then press **#**

Hear a prompt requesting that you spell the first four letters of your name.

9. Using table 2A, enter the first four letters of your last name exactly with two key presses per letter:

OR to re-enter your name

press 

Hear confirmation.

10. To accept the spelling

press 

OR to re-enter

press 

A 2 and 1	J 5 and 1	S 7 and 3
B 2 and 2	K 5 and 2	T 8 and 1
C 2 and 3	L 5 and 3	U 8 and 2
D 3 and 1	M 6 and 1	V 8 and 3
E 3 and 2	N 6 and 2	W 9 and 1
F 3 and 3	O 6 and 3	X 9 and 2
G 4 and 1	P 7 and 1	Y 9 and 3
H 4 and 2	Q 1 and 1	Z 1 and 2
I 4 and 3	R 7 and 2	

*Table 2A:  
Corresponding key  
sequences for letters*

The first key you press indicates the number on the key and the second indicates a letter's position on that key.

For example, to enter a Y, you would press 9 and then press 3 to specify that Y is the third letter on the 9 key.

If your last name consists of fewer than four letters, you just enter the letters needed.

For example, if John Simon wants to enter his last name he follows these steps:

1. For the first letter press **7 3**

CLASSIC MAIL system's recorded voice responds "S."

2. For the second letter press **4 3**

CLASSIC MAIL system's recorded voice responds "I."

3. For the third letter press **6 1**

CLASSIC MAIL system's recorded voice responds "M."

4. For the fourth letter press **6 3**

CLASSIC MAIL system's recorded voice responds "O."

It's a good idea to write down the sequence of keys corresponding to your last name prior to entering these digits. After you complete the spelling, you will hear a spelling confirmation message and a message telling you about any messages in your mailbox.

***Note:** Because Q and Z don't appear on the dial pad, they require a special combination of key presses. See table 2A.*

## **Recording a Greeting**

---

Until you record your own greetings, callers leaving messages in your mailbox will hear your recorded name and the CLASSIC MAIL system's instructions for leaving a message.

You can record two of your own custom greetings and change either of them when ever you like. Having two greetings (*primary* and *alternate*) is useful because you can use one for everyday business and another, for example,

for those times when you're away from the office (*"I'm not in today but please leave a message and I'll be alerted and return your call immediately"*) or out of town (*"I'm out of town until Wednesday, but if you leave a message, I'll get back to you when I return. Or dial 0 and ask our attendant to connect you to Sue Redford who can help you with your order"*).

The CLASSIC MAIL system allows callers to "mark" their messages urgent. Urgent messages will be delivered to you before other messages. To use this feature, you might want to add a sentence to your greeting such as, *"If this message is urgent, press pound after you record your message, and press three to mark it urgent."*

***To record a greeting:***

1. Open your mailbox.
2. To change mailbox options press **3**

A message about the status of your mailbox and instructions about recording a greeting plays.

3. To record a mailbox greeting press **1**

4. To record a primary greeting                     press **1**
- OR to record an alternate greeting           press **2**
5. Record your greeting at the tone.
6. To end the recording                             press **#**
- OR to start over                                 press **★**
7. To listen to the confirmation                 press **#**

The greeting is now installed.

Each greeting can be up to three minutes long.

## **Switching a Greeting**

---

*To switch a greeting from alternate or primary:*

1. Open your mailbox.
2. To change mailbox options                     press **3**

If the alternate greeting is in operation, the CLASSIC MAIL system instructs you:

3. To record mailbox greeting(s) press **1**

4. To switch the greeting that is currently in use press **3**

A confirmation message plays.



# Your Messages

# 3. Your Messages

## **Letting the CLASSIC MAIL System Answer Your Calls**

---

The CLASSIC MAIL system will answer your incoming calls if you do not. If the CLASSIC MAIL system answers, callers will be greeted and instructed to leave a message.

## **Knowing When You Have Messages**

---

Anytime you have a new message, the CLASSIC MAIL system attempts to let you know. The CLASSIC MAIL system's normal method of message alert is to call you on your intercom line and announce that a new message has arrived. The CLASSIC MAIL system will continue these attempts until you have either listened to the complete message or deleted it.

The CLASSIC MAIL system allows you to turn this feature off or on, and to set the time interval between alert attempts. You must have your telephone's Intercom Voice Announcement feature turned on in order to make this feature work.

***To turn message waiting alert off/on:***

1. Open your mailbox.

A status message plays.

2. To change your mailbox options                      press **3**
3. To setup message waiting alert                      press **5**
4. To turn message waiting alert off/on                      press **1**

***To change the message waiting alert interval:***

1. Open your mailbox.

A status message plays.

2. To change your mailbox options                                  press **3**
3. To setup message waiting alert    press **5**
4. To change the message waiting alert  
interval    press **2**
5. Enter an interval number between five  
and two-hundred fifty-five minutes.

You can also set up an off-site message alert. If you do, the CLASSIC MAIL system will call you at an outside phone number, or pager when a new message arrives. See Chapter 4.

The CLASSIC MAIL system can also light the message waiting light on your telephone, or a light on a message waiting panel whenever you have new messages. See the *CLASSIC MAIL System Reference Guide* for instructions.

## Listening to Your Messages

When you listen to your messages, you'll hear them in this order:

1. Urgent messages
2. New messages and certified receipts
3. Previously heard messages

Urgent messages and certified receipts are discussed later in the section "Special Delivery Options."

### *To listen to your messages:*

1. Open your mailbox.

Hear a status message.

2. To hear the first message

press **1**

If the message is urgent, hear a prompt. If a certified message that you sent has been received, hear a receipt.

3. To hear the next message press **2**

After listening to your messages, if you want the CLASSIC MAIL system to hang up:

4. Return to the top-level menu press **\***

A message telling you to enter your mailbox number and password plays.

5. To make the CLASSIC MAIL system disconnect press **#**

## Handling Your Messages

---

If you hangup after listening to a message, the CLASSIC MAIL system automatically saves the message for you as an old message.

While listening to a message, you have several options. The dial-pad menu in Figure 3A lists these options.

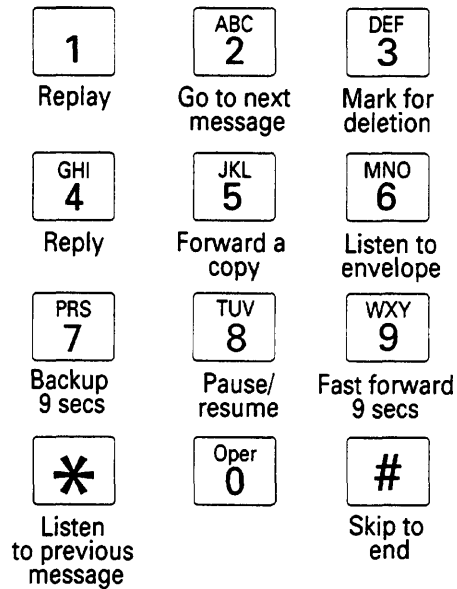

*Figure 3A: Dial pad menu of touch tone commands*

## Deleting and Undeleting Messages

---

You can delete a message by “marking it for deletion” and then hanging up. Prior to hanging up you can “undelete” any message accidentally marked for deletion.

### *To delete a message:*

1. Listen to a message.
2. To mark the message for deletion                      press **3**  
Hear confirmation.

### *To undelete a message:*

1. While listening to messages                      press **★**
2. To undelete a message just deleted                      press **4**  
Hear confirmation.

If the CLASSIC MAIL system tells you that your mailbox is getting full, you should start deleting your messages.



## Replying to a Message

---

If you receive a message from other mailbox owners, you can reply directly with a call to their intercoms (if the owner has an intercom number) or reply with a message to their mailbox.

### ***To call the sender's intercom:***

1. Listen to the message.

2. To reply

press **4**

3 To call the sender

press **1**

You'll be transferred to the sender's intercom. If the sender does not answer, you can leave a message.

**Note:** *To reply directly to the sender's intercom, you must be listening to your messages from an outside telephone, and it is required that the sender sent you the message from their mailbox by using the "send message" feature.*

Any message you leave when you're replying to a message can be marked as urgent or certified or both urgent and certified.

***To reply directly to the sender's mailbox:***

1. Listen to the message.
2. To reply press **4**
3. To reply with a message press **2**
- OR to cancel press **★**
4. Record your message at the tone and press **#**

**Note:** *To reply directly to the sender's mailbox requires that the sender sent you the message from their mailbox by using the "send message" feature.*

## Forwarding a Copy of a Message

---

You can forward a copy of a message. The person who receives the message can then save it, delete it, or respond to it. You can mark a message you're forwarding as either urgent or certified, or as both.

### *To forward a copy of a message:*

1. Listen to a message.
2. To forward the message press **5**
3. Record an introduction press **#**
4. To accept the recording press **#**
5. Enter a destination mailbox or group list number (801 to 805).

Hear confirmation.

6. To accept

press **#**

OR to cancel

press **\***

Hear confirmation.

## **Listening to Envelope Information**

---

Messages are “enclosed in envelopes.” Envelopes include information that tells you when the message was sent and (if the message was sent from another mailbox) by whom.

### ***To listen to a message envelope:***

1. Listen to a message.

2. To hear envelope information

press **6**

## Sending a Message

---

### *To send a message from your mailbox:*

1. Open your mailbox.
2. To send a message press **2**
3. Record your message at the tone and press **#**  
OR to continue the recording press **2**
4. To accept the recording press **#**
5. Enter the destination mailbox or group list number (801 to 805).  
OR to use the company directory press **#**  
Hear confirmation.
6. To send the message press **#**  
OR to mark the message urgent press **1**

OR to send the message by certified delivery press **2**

OR for both urgent and certified options press **3**

OR to cancel press **★**

A confirmation plays.

## Special Delivery Options

The messages that callers leave in your mailbox maybe marked with the “special delivery” options of urgent or *certified* (or both urgent and certified). An urgent message is preceded by the prompt “*urgent message*” when you listen to it. When you listen to a certified message, a “receipt” is sent back to the mailbox owner who sent you the message. For example: “*Mary Franklin has listened to the following message at 2:00 p.m., December 13.*” The receipt is followed by a playback of the message that was sent. (You can fast forward through this playback as well as any other message. See the dial-pad menu shown in Figure 3A.)

## Group Lists

---

To send a message to a group, you first have to create a group list. A group list can be as big as all the mailboxes in your system (this group list is already setup for you by the CLASSIC MAIL system) or as few as two. When you create a group list, you assign and record a name such as “Managers” and the system assigns a number from 802 to 805 (801 is automatically and permanently assigned to the all-mailboxes group list) to the list. Then you “enroll” the mailbox number of everyone you want included. When have finished creating the list, you can review the list.

### *To create and review a group list:*

1. Open your mailbox.
2. To change mailbox settings

press **3**

3. For group lists press **3**  
  
Hear an informational message.  
(If group lists already exist,  
you'll hear their names and numbers).
4. To create a group list press **1**
5. Record a name for the list at the tone.
6. To hear confirmation press **#**
7. Enter the mailbox number.  
  
OR to use the company directory press **#**  
  
Hear confirmation.
8. Repeat steps 6 and 7 until all the mailboxes you want  
to enroll are included.
9. To end press **★**
10. To review the list press **4**



Deleting a group list eliminates the group list name and number and removes all associated mailboxes from the list.

***To delete a group list:***

1. Open your mailbox.
2. To change mailbox settings press **3**
3. For group lists press **3**
4. To delete a group list press **3**
5. Enter the number of the group list you want to delete.  
Hear confirmation.
6. To verify press **#**  
OR to cancel press **★**

**Off-Site  
Message  
Alert**

# 4. Off-Site Message Alert

## How Off-Site Message Alert Works

---

With off-site message alert, you can be notified at an outside phone or at a pager each time a new message arrives in your mailbox. You can setup this feature to call you at either of two numbers. For example, if you're a realtor showing a house you could tell the CLASSIC MAIL system to dial the phone number of the house first and, if you don't answer after a specified number of attempts, the CLASSIC MAIL system will dial a car phone or a pager.

You can turn this feature on and off, set how frequently you receive an alert, and set how many alert attempts you want the CLASSIC MAIL system to make. Finally, you can select off-site message alert for only messages that are marked urgent.

Off-site message alert works this way:

- Set up off-site message alert by entering the phone or pager numbers at which you want to be contacted. (You can list up to two phone numbers to be called in succession or up to two pager numbers or one of each.)
- Turn on the feature when you leave your office and indicate whether you want to be alerted to all new messages or only those marked urgent.
- The CLASSIC MAIL system calls you “*n*” times at the first number at regular intervals, where “*n*” is the number of call attempts you set. (You set the number of call attempts between 1 and 9, and the interval between 5 and 999 minutes.)
- Next, if you specify a second number, the CLASSIC MAIL system calls you there the specified number of attempts.

- If the CLASSIC MAIL system reaches your pager, it displays the number you've specified to call to check your messages. If the CLASSIC MAIL system reaches you at a phone number, a recorded voice says there is a new message for you and you press any key and open your mailbox to listen to the message. After listening, you can proceed with regular message disposition.
- If another message arrives, the CLASSIC MAIL system alerts you again.
- If the CLASSIC MAIL system cannot reach you at the specified numbers, it will leave a message in your mailbox telling you of its attempts. This message will be automatically deleted once you listen to it.

Telling the CLASSIC MAIL system which phone or pager to call can be as simple as entering a seven-digit number; however, sometimes your off-site number will require an additional prefix or an area code.

In addition, some pagers may require a pause to allow them to answer the page and display the number (or mailbox) you should call, or an extra code such as the star or the pound key. If a pause or a special code is required, you *embed* them in the sequence of numbers by first entering the star key. For example, if your pager requires a pause, you would enter the pager number to call, then the star followed by a number (1 to 9) to indicate how long a pause (in seconds) is required, then your mailbox number:

1 408 555 1212 \*8 12

┌ Pause 8 seconds  
└ Mailbox Number

If your pager required a pound sign to be entered after the number of the phone (or, in this case, the mailbox) from which the page came, you would enter a star and pound sign at the end:

1 408 555 1212 \*812 \*#

└ Pound Sign

Once all the codes are entered, you press # twice to tell the CLASSIC MAIL system that the operation is finished and to accept the entry.

The CLASSIC MAIL system allows you to enter a total of up to 32 digits and accepts the several keys as special codes to cover various paging circumstances.

The special key codes are shown in Table 4A.

★★	Insert a “star” into the dialing sequence
★ 0	Pause dialing until dial tone then continue
★ #	insert a ‘bound’ into the dialing sequence
★ (1-9)	Pause for 1-9 sec. in the dialing sequence

*Table 4A:  
Special codes*

## Setting Up Off-Site Message Alert to a Phone

*To set up off-site message alert to an off-site phone:*

1. Open your mailbox.
  2. To change mailbox settings press **3**
  3. To setup off-site message alert press **2**
  4. To setup the first number press **1**  
OR to set up the second number press **2**
  5. To tell the CLASSIC MAIL system to dial  
an outside phone press **1**
  6. Enter the off-site phone number press **#**  
(including any extra digits or codes)
  - If you make a mistake press **★**
- Hear confirmation.



7. To accept

press **#**

OR to re-enter the number

press **\***

Repeat steps 4 through 7 to set up a second off-site phone or go through the steps that follow for setting up a pager.

### **Setting Up Off-Site Message Alert to a Pager**

*To setup off-site message alert for a pager:*

1. Open your mailbox.

2. To change mailbox settings

press **3**

3. To setup off-site message alert

press **2**

4. To setup the first number

press **1**

OR to set up the second number

press **2**

5. To dial a pager

press **2**

6. Enter the pager number (including any extra digits or codes) press **#**

If you make a mistake press **★**

Hear confirmation.

7. To accept press **#**

OR to re-enter the number press **★**

Repeat steps 4 through 7 to set up a second off-site pager.

### **Turning Off-Site Message Alert On or Off**

---

*To turn off-site message alert on or off:*

1. Open your mailbox.

2. To change mailbox settings press **3**

3. To setup off-site message alert press **2**

4. To turn off-site message alert off/on for the first number press **3**

OR to turn it off/on for a second number press **4**

Hear confirmation.

5. To be alerted to new urgent messages only, OR, if off-site message alert is already set up for urgent messages only, and you want of be alerted of all new messages press **5**

Hear confirmation.

## Setting the Number of Attempts

---

### *To set the number of ring attempts:*

1. Open your mailbox.

2. To change mailbox settings press **3**

3. To setup off-site message alert press **2**

4. To select level 1 press **1**

5. To change the number of attempts press **3**

Hear a message about the number of attempts.

6. Enter a number from **1** to **9**

Hear confirmation.

## **Determining How Often You're Alerted**

---

*To specify the number of times the CLASSIC MAIL system will alert you at a given phone or pager number:*

1. Open your mailbox.

2. To change mailbox settings press **3**

3. To setup off-site message alert press **2**

4. To select level 1 press **1**

5. To change the interval and hear how alert is currently set up press **4**

6. To signify the number of minutes between alerts, enter a number between 5 and 999.

Hear confirmation.

## **Reviewing the Settings for Off-Site Message Alert**

---

*To review the off-site message alert settings:*

1. Open your mailbox.

2. To change mailbox settings press **3**

3. To setup off-site message alert press **2**

4. To review the settings press **6**

The CLASSIC MAIL system will confirm: the level of off-site message alert, the phone or pager number it's calling, the number of attempts it will make, the interval between attempts, and whether you'll be alerted on all new messages or only just the urgent ones, for each of the two numbers you may have specified.

**Transferring  
Calls into the  
CLASSIC MAIL  
System**

# 5. Transferring Calls Into the CLASSIC MAIL System

The procedure you use to transfer incoming callers into the CLASSIC MAIL system will depend upon the type of Merlin telephone system you have. If you have a Merlin 206, 410, 820, or Merlin Plus, use the procedure, “*Transferring Outside Callers,*” that immediately follows. If you have a Merlin 1030/3070 operating with “line pool” keys on your telephones, use the procedures described in the sections, “*Merlin 1030/3070 Transfer Procedures for Attendants,*” and “*Merlin 1030/3070 Transfer Procedures for Non-Attendants,*” located at the end of this chapter.



## Transferring Outside Callers

---

*To transfer a caller to the CLASSIC MAIL system:*

1. Ask the caller to hold.
2. Press the hold button.
3. Select a CLASSIC MAIL system access line,

then

press



CLASSIC MAIL system access lines are the lines with the “Voice Mail” labels on your telephone line buttons.

You should now be connected to the CLASSIC MAIL system.

4. To transfer a caller

press



An instruction to enter the outside line number to be answered plays.

5. Enter the line number of the outside line the call is on.  
Line 1 normally corresponds to the outside line button directly above the intercom button on your phone.

Figure 5A shows the typical line numbering method used by Merlin 206, 410, 820, and Merlin Plus telephone systems.

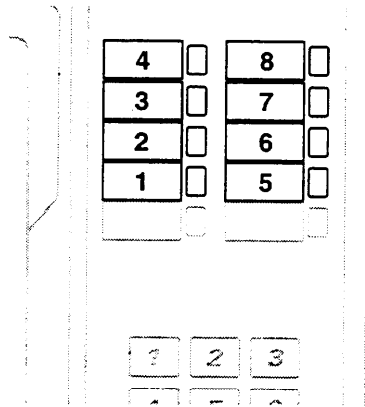

*Figure 5A: Line numbering for Merlin 206, 410, 820 and Plus telephones.*

If the caller wants to be transferred into the CLASSIC MAIL system in order to retrieve messages from their own mailbox, hang up now.

If the caller wants to leave a message for someone else, continue with steps 6 through 8.

6. Enter the intercom or mailbox number of the destination party.

7. If you know the destination party is not available, or if you want to place the calling party directly into the mailbox without ringing the intercom

press 

8. Hang up.

***Note:** There may be situations where you are unable to transfer callers into the CLASSIC MAIL system because you lack the necessary line appearances on your telephone. In these situations, we recommend that you transfer the caller back to the attendant, who can then transfer the caller into the CLASSIC MAIL system.*

### **Merlin 1030/3070 Transfer Procedures for Attendants**

If you have a Merlin 1030/3070 system and you are the attendant, use the procedure that follows. Note that your telephone should have line appearance buttons similar to those shown in Figure 5B to use this procedure.

#### ***To transfer a caller to the CLASSIC MAIL system:***

1. Ask the caller to hold.

2. Press the hold button.

3. Select a CLASSIC MAIL system access line

then

press



*CLASSIC MAIL system access lines are the lines with the “Voice Mail” labels on your telephone line buttons.*

You should now be connected to the CLASSIC MAIL system.

4. To transfer a caller

press



An instruction to enter the outside line number to be answered plays.

5. Enter the line number of the outside line the call is on.

Line 1 normally corresponds to the outside line button directly above the intercom button on your phone.

Figure 5B shows the typical line numbering method used by Merlin 1030/3070 attendant telephones.

If the caller wants to be transferred into the CLASSIC MAIL system in order to retrieve messages from their own mailbox, hang up now.

Figure 5B: Line numbering for Merlin 1030/3070 Attendant telephones

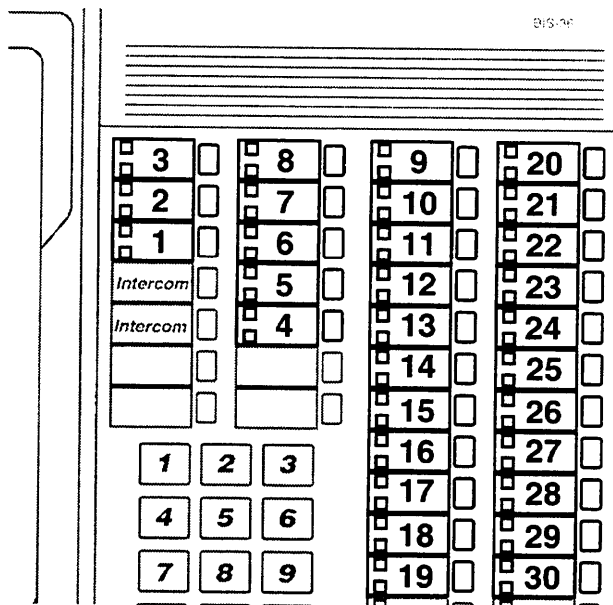

If the caller wants to leave a message for someone else, continue with steps 6 through 8.

6. Enter the intercom or mailbox number of the destination party.

7. If you know the destination party is not available, or if you want to place the calling party directly into the mailbox without ringing the intercom

press 

8. Hang up.

### **Merlin 1030/3070 Transfer Procedures for Non-Attendants**

---

If you have a Merlin 1030/3070 system and your telephone has “line pool” keys, you will not be able to transfer callers into the CLASSIC MAIL system using the previously described procedure because you will not know the line number of the outside line to transfer. In this case, we recommend that you either:

- Transfer the caller back to the attendant and ask the attendant to transfer the caller to the CLASSIC MAIL system.

- Tell the caller that you will transfer them to the CLASSIC MAIL system. Transfer the caller to intercom 11 and hang up.  
The CLASSIC MAIL system will prompt the caller to enter the intercom number of the party they want to reach. After they enter it, the CLASSIC MAIL system will transfer them. You will not be able to dial the desired intercom number for them because your Merlin telephone does not generate Touch Tone signals during intercom calls. These Touch Tone signals are required to dial into CLASSIC MAIL system. As a courtesy to the caller, it's a good idea to tell them in advance the intercom number of their desired party. Note that this procedure will not work for calls arriving on lines that have been identified to the CLASSIC MAIL system as being "out of service."

**CLASSIC MAIL MAILBOX USER GUIDE**

585-321-114

2911034-1

Issue 1

June 1994