



AT&T 555-230-601  
Issue 2  
July 1993

# **DEFINITY® Communications System Generic 3**

## Planning and Configuration

While reasonable effort was made to ensure that the information in this document was complete and accurate at the time of printing, AT&T can not assume responsibility for any errors. Changes and/or corrections to the information contained in this document may be incorporated into future issues.

#### **YOUR RESPONSIBILITY FOR YOUR SYSTEM'S SECURITY**

You are responsible for the security of your system. AT&T does not warrant that this product is immune from or will prevent unauthorized use of common-carrier telecommunication services or facilities accessed through or connected to it. AT&T will not be responsible for any charges that result from such unauthorized use. Product administration to prevent unauthorized use is your responsibility and your system administrator should read all documents provided with this product to fully understand the features available that may reduce your risk of incurring charges.

#### **FEDERAL COMMUNICATIONS COMMISSION (FCC) STATEMENT**

This equipment generates, uses, and can radiate radio-frequency energy and, if not installed and used in accordance with the instruction manual may cause interference to radio communications. It has been tested and found to comply with the limits for a Class A computing device pursuant to Subpart J of Part 15 of FCC Rules, which are designed to provide reasonable protection against such interference when operated in a commercial environment.

Operation of this equipment in residential areas is likely to cause interference, in which case the user at his/her own expense will be required to take whatever measures may be required to correct the interference.

#### **TRADEMARK NOTICE**

CallMaster, CONVERSANT, DEFINITY, HORIZON, MERLIN, MEGACOM, TELESEER, and QUORUM are registered trademarks of AT&T.

AUDIX and CallVisor are trademarks of AT&T.

Audichron is a registered trademark of the Audichron Company.

VT is a trademark of Digital Equipment Corporation.

PagePac is a registered trademark of the Dracon Division of the Harris Corporation.

HOLADAY is a trademark of Holaday Industries.

IBM is a registered trademark of International Business Machines Corporation.

PORTA SYSTEMS is a registered trademark of Porta Systems, Inc.

#### **ORDERING INFORMATION**

To order copies of this addendum:

**Call:** AT&T Customer Information Center at 1-800-432-6600  
In Canada call 1-800-255-1242

**Write:** AT&T Customer Information Center  
2855 North Franklin Road  
P.O. Box 19901  
Indianapolis, Indiana 46219-1385

**Order:** Document No. 555-230-600  
Issue 1, January 1992

---

# Contents

<b>INTRODUCTION</b> .....	1
General Information .....	1
How to Use This Document .....	4
<b>FEATURE DETERMINATION</b> .....	7
Features That Require Additional Hardware and/or Software .....	12
<b>SYSTEM PARAMETERS</b> .....	29
<b>SYSTEM VERSION DETERMINATION</b> .....	43
<b>HARDWARE AND SOFTWARE DETERMINATION</b> .....	45
Voice/Data Terminal Equipment Assignments .....	45
Voice/Data Terminal Totals .....	45
Data Communications Equipment .....	52
Display Terminals and Printers .....	61
Distributed Communications System (DCS).....	65
Traffic Considerations .....	72
Network Access Facilities .....	73
Circuit Pack Determination .....	75
Software Determination .....	95
Cabinet Determination (DEFINITY Generic 1 and Generic 3) .....	96
Ordering Information .....	100
<b>ENVIRONMENTAL REQUIREMENTS</b> .....	103
General .....	103
Floor Plans and Layouts .....	103
Floor Loading.....	103
Earthquake Protection .....	104
Floor Space .....	104
Desktop Space .....	110

---

Optional Equipment Floor and Desktop Space .....	110
Wall Space Required .....	110
Temperature and Humidity .....	111
Air Purity.....	112
Lighting .....	112
Noise .....	112
Additional Considerations .....	113
<b>POWER AND GROUNDING .....</b>	<b>115</b>
General .....	115
AC Power Requirements .....	115
DC Power Requirements.....	122
Grounding .....	128
Lightning Protection .....	129
Sneak Current Protection .....	129
Standby Power System—Multi-Carrier Cabinet System .....	130
Standby Power—Single-Carrier Cabinet System .....	132
House Wiring.....	133
<b>UPGRADES AND ADDITIONS .....</b>	<b>135</b>
System 75 Upgrade to DEFINITY Generic 1 PPN Without Duplication .....	135
System 75 Upgrade to DEFINITY Generic 1 PPN With Duplication.....	136
System 75 Upgrade to DEFINITY Generic 1 EPN Without Duplication .....	137
System 75 Upgrade to DEFINITY Generic 1 EPN With Duplication.....	137
System 75 XE Upgrade To DEFINITY Generic 1 PPN Without Duplication .....	138
System 75 XE Upgrade to DEFINITY Generic 1 PPN With Duplication .....	139
System 75 XE Upgrade to DEFINITY Generic 1 EPN Without Duplication.....	140
System 75 XE Upgrade to DEFINITY Generic 1 EPN With Duplication .....	140
Port Circuit Pack Upgrades for DEFINITY Generic 3r .....	142
DEFINITY Generic 1 Upgrade to DEFINITY Generic 3r PPN .....	143
DEFINITY Generic 1 PPN Upgrade to DEFINITY Generic 3r EPN MCC Without Duplication .....	143

---

DEFINITY Generic 1 EPN MCC Upgrade to DEFINITY Generic 3r EPN MCC With Duplication .....	144
DEFINITY Generic 1 EPN SCC Upgrade to DEFINITY Generic 3r EPN SCC Without Duplication .....	145
DEFINITY Generic 1 PPN SCC Upgrade to DEFINITY Generic 3r EPN SCC Without Duplication .....	145
DEFINITY Generic 1 EPN SCC Upgrade to DEFINITY Generic 3r EPN SCC With Duplication .....	146
DEFINITY Generic 1 PPN SCC Upgrade to DEFINITY Generic 3r EPN SCC With Duplication .....	147
Additions to the System .....	149
<b>REFERENCES</b> .....	151
<b>ABBREVIATIONS AND ACRONYMS</b> .....	155
<b>GLOSSARY</b> .....	160
<b>INDEX</b> .....	177

---

## Figures

Figure 1.	CDR Output Devices and Connections .....	54
Figure 2.	Data Endpoint (Terminal, Personal Computer, Host, and Customer-Provided Equipment) Connections .....	59
Figure 3.	Data Endpoint (EIA-232C) Connections .....	60
Figure 4.	G1 and G3i DCS Used in a Long Haul and Short Haul Connection .....	66
Figure 5.	G3r to G3r DCS Used in a Long Haul and Short Haul Connection .....	67
Figure 6.	G3r to G1 DCS Used in a Short Haul Connection .....	68
Figure 7.	G3r to G2 Traditional Module DCS Used in a Short Haul and Long Haul Connection .....	69
Figure 8.	G3r to G2 Universal Module DCS Used in a Short Haul and Long Haul Connection .....	70
Figure 9.	G3r to G3i and G3r to G3r DCS Plus Used in a Long Haul Connection .....	71
Figure 10.	Typical Single-Carrier Cabinet Floor Plan With Processor Port Network Only .....	105
Figure 11.	Typical Multi-Carrier Cabinet Floor Plan With Processor Port Network and Auxiliary Cabinet .....	106
Figure 12.	Typical Floor Plan With Processor and Expansion Port Networks .....	107
Figure 13.	Typical Floor Plan With Processor and Expansion Port Networks (G3r Only) .....	108
Figure 14.	Earthquake Environment (North American Continent) .....	109
Figure 15.	Typical Multi-Carrier System AC Power and Grounding (EPN Colocated) .....	116
Figure 16.	Typical Multi-Carrier AC Power and Grounding (Remote EPN) .....	117
Figure 17.	AC Power Requirements for a Single-Carrier Cabinet System .....	118
Figure 18.	AC Power Requirements for a Single-Carrier System (Remotely Located EPN) ...	119
Figure 19.	Typical Single-Carrier Power and Grounding Layout (EPN Colocated) .....	120
Figure 20.	Typical Single-Carrier AC Power and Grounding Layout (Remotely Located EPN)	121
Figure 21.	Typical Multi-Carrier Cabinet System DC Power and Grounding Layout (EPN Colocated) .....	122
Figure 22.	Typical Multi-Carrier Mixed AC/DC Power and Grounding Layout (EPN Colocated) .....	125
Figure 23.	Typical Multi-Carrier Mixed AC/DC Power and Grounding Layout (Remotely Located EPN) .....	126
Figure 24.	Typical Single-Carrier DC Power and Grounding Layout (EPN Colocated) .....	127

---

## Tables

Table A.	Feature Determination .....	7
Table B.	Features Requiring Additional Hardware and/or Software .....	12
Table C.	System Parameters .....	29
Table D.	Station Allocation Characteristics .....	46
Table E.	Users and Required Equipment .....	46
Table F.	Voice/Data Terminal Quantities.....	47
Table G.	Adjunct Quantities and Voice Terminal Compatibility .....	49
Table H.	Terminal Equipment Limits .....	50
Table I.	Data Communications Equipment .....	52
Table J.	System Data Terminals .....	62
Table K.	System Printers .....	63
Table L.	Network Access Facilities .....	73
Table M.	Summation of Interface Circuit Packs .....	94
Table N.	System Software PEC Codes .....	95
Table O.	Allowable Relative Humidity .....	111
Table P.	System Power Consumption and Heat Dissipation .....	114
Table Q.	-48 Volt DC Input Power Requirements .....	123
Table R.	AC Power Requirements .....	130
Table S.	DC Power Requirements .....	131
Table T.	UPS Power Requirements .....	132
Table U.	Port Circuit Pack Upgrades .....	142

## INTRODUCTION

### General Information

This document, *DEFINITY® Communications System Generic 1 and Generic 3—Planning and Configuration*, 555-230-600, is used by the AT&T Account Team to determine a customer's requirements and to collect the information needed to estimate hardware quantities for DEFINITY® Communications System Generic 1 or Generic 3. Throughout the rest of this document, this system is referred to as either DEFINITY Generic 1, Generic 3, G1, G3i, or G3r. Software releases G1 (a Generic 1 release), G3i (a Generic 3 release), and G3r (a Generic 3 release) are covered. The term G3 applies to both G3i and G3r. Where there is a difference between the G3i and G3r releases, the text specifies the release.

The hardware quantities estimate can be recorded on the tables provided in this document. The information obtained during the planning and configuration process is used for negotiations and for initially pricing a system. This information serves as the foundation for the proposal and for the post-sale communications survey. The information gathered here can then be input to the Delivery Operation and Support System (DOSS) Configurator.

This document assumes that AT&T Account Team members are familiar with DEFINITY Generic 1 and Generic 3 and its associated Price Element Codes (PECs).

**The Business Communications Systems (BCS) Design Center (BDC) should always be consulted to provide engineering support for Automatic Alternate Routing (AAR), Distributed Communications System (DCS), Integrated Services Digital Network (ISDN), Uniform Dial Plan (UDP) and DS1 feature configurations, and any time processor occupancy is in question.**

**If a configuration has a Processor Port Network (PPN) and an off-premises (out of building or in a different room) Expansion Port Network (EPN), the Premises Services Consultant (PSC) must be consulted for design of the fiber link.**

Any statement appearing in the following material is limited by, and subject to, all terms and provisions of the Purchase or Master Agreement for DEFINITY Generic 1 or DEFINITY Generic 3, including those limiting warranties and liabilities of AT&T.



For a complete listing of the system's technical specifications including cabling distances, call progress and signaling tones, signaling protocols, trunk specifications, etc., refer to the *DEFINITY Communications System Generic 1 and Generic 3—System Description*, 555-230-200.

This issue replaces all previous issues of this document. Reasons for reissue are as follows:

- To add the following new features:
  - Alternate Facility Restriction Levels
  - Administration Without Hardware
  - CallVisor™ Adjunct Switch Application Interface (ASAI)
  - Administered Connection/Access Endpoint
  - Alphanumeric Dialing
  - Automatic Available Split
  - Automatic Trunk Measurement System
  - Basic Rate Interface (BRI) Multipoint
  - Bulk Station Administration
  - Call Detail Recording (CDR) Variable Format Records
  - Call Prompting
  - Call Vectoring
  - Calling Party Number/Billing Number (was SID/ANI)
  - Call Work Codes
  - D-Channel Backup
  - DCS Over Primary Rate Interface (PRI)
  - Dialed Number Identification Service
  - Enhanced Trunk Signaling and Error Recovery
  - Enhanced Terminal Administration
  - Extension Number Portability
  - Facility/Non-Facility Associated Signaling
  - Functional Scheduling Enhancement
  - Inbound Call Management (ICM)
  - Lookahead Interflow
  - Main/Satellite Extended Trunk Access
  - Malicious Call Trace
  - Multi-User System Management Access
  - Outgoing Trunk-to-Outgoing Trunk Transfer
  - Restricted/Unrestricted Call Lists

- 
- Restriction—Toll
  - Security Violations Notification
  - Software Defined Data Network (SDDN)
  - Stroke Counts
  - System Reload Indication
  - Terminal Translation Initialization
  - Unrestricted 5-Digit Uniform Dial Plan (UDP)
  - Vector Directory Number (VDN) Reports
  - To add the following new universal circuit packs (older circuit packs are included to facilitate upgrades to DEFINITY Communications Systems Generic 1 from older systems):
    - TN464 32-Channel E1 Trunk
    - TN553 Packet Data
    - TN556 ISDN-BRI Line
    - TN570 Expansion Interface
    - TN572 Switch Node Clock
    - TN573 Switch Node Interface
    - TN574 DS1 Converter
    - TN577 Packet Gateway
    - TN744 Call Classifier
    - TN771 Maintenance/Test
  - To add the following hardware:
    - 715 Business Communications System (BCS) G3r-Management Terminal (G3r-MT)
    - Enhanced Attendant Console (302A)
    - Enhanced Selector Console (26A)
    - G3r Center Stage Switch (CSS)

### How to Use This Document

This document is written to lead you, step by step, through the planning and configuration process. Detailed instructions are given throughout the document. The following list is a brief summary of the steps to be followed when planning and configuring your system.

1. Use Table A to identify all desired features.
2. Use Table B to determine any additional hardware and/or software that may be required for specific features.
3. Review Tables C and D. These tables, in conjunction with information derived from Tables A and B, should be helpful in determining which version of the system is needed.
4. Use Table E to list the system users and their individual equipment needs.
5. Use Table F to determine the total number of each type of voice and data terminals. Information for this table is obtained from Table E.
6. Use Table G to determine the total number of each type of voice and data terminal adjunct. Information for this table is obtained from Table E.
7. Use Table H to determine if any of the terminal equipment limits have been exceeded.
8. Review the data communications equipment information that is provided.
9. Use Table I to list the quantities of data communications equipment.
10. Determine if traffic engineering calculations should be made.
11. Use Table J to determine which data terminals are needed, and in particular the Manager I or G3r-Management Terminal (G3r-MT).
12. Use Table K to determine which system printer is needed.
13. Determine the number of each type of network access facility to be used per Table L.
14. Determine the number of each type of circuit pack to be used and list the totals in Table M.
15. Determine the combination of cabinets for DEFINITY Generic 1 using the tables in "Multi-Carrier Cabinet Configuration" and "Single-Carrier Cabinet Configuration."
16. Complete the ordering information using the information listed in the tables that have already been filled out.
17. Review the following sections so that any necessary equipment room preparations and advance planning considerations can be made for the new system.
  - "Environmental Requirements"
  - "Power and Grounding"
  - "Upgrades and Additions"

The system supports the use of many other AT&T products. Refer to each product's respective documentation for planning and configuration information.

The rest of this document is divided into the following sections:

- **Feature Description**
- **System Parameters**
- **System Version Determination**
- **Hardware and Software Determination**
- **Environmental Requirements**
- **Power and Grounding**
- **Upgrades and Additions**
- **References**
- **Abbreviations and Acronyms**
- **Glossary**
- **Index**

## FEATURE DETERMINATION

Table A provides an alphabetical list of all DEFINITY Generic 1 and Generic 3 features. The table identifies the system version that supports each feature and whether additional hardware and/or software are required. If additional software is required, it must either be loaded in the system and/or the associated feature option must be enabled on the System Parameters Customer Options form. Features and hardware must be identified to determine which version of the system to order. For example, if Integrated Digital Services Network-Basic Rate Interface (ISDN-BRI) is required, a G3 system must be ordered because ISDN-BRI is not supported by G1.

On Table A, place a check mark (√) in the *Desired* column beside each required feature.

**Note:** Additional information on features can be found in the *DEFINITY® Communications System Generic 1 and Generic 3—Feature Description*, 555-230-201.

After the features have been identified, use Table B (Features Requiring Additional Hardware and/or Software) to identify the specific hardware and/or software required for each feature.

Use Table C (System Parameters) to determine which version of the system is required, based on the configuration of features and hardware selected.

**TABLE A. Feature Determination**

Feature	G1	G3i	G3r	Additional Hardware Required	Additional Software Required	Desired
Abandoned Call Search	√	√	√	√		
Abbreviated Dialing	√	√	√	√	√	
CallVisor Adjunct Switch Application Interface		√	√	√	√	
Administered Connection/Access Endpoint		√	√	√		
Administration Without Hardware		√	√			
Agent Call Handling	√	√	√		√	
Alphanumeric Dialing		√	√			
Alternate Facility Restriction Levels			√			
Attendant Auto-Manual Splitting	√	√	√			
Attendant Call Waiting	√	√	√			
Attendant Control of Trunk Group Access	√	√	√	√		
Attendant Direct Extension Selection With Busy Lamp Field	√	√	√	√		
Attendant Direct Trunk Group Selection	√	√	√	√		
Attendant Display	√	√	√	√		
Attendant Recall	√	√	√	√		
Attendant Release Loop Operation	√	√	√			
Audio Information Exchange (AUDIX™) Interface	√	√	√	√		
Authorization Codes	√	√	√		√	

**TABLE A (continued).  
Feature Determination**

Feature	G1	G3i	G3r	Additional Hardware Required	Additional Software Required	Desired
Automatic Alternate Routing (AAR) and Automatic Route Selection (ARS)	√	√	√		√	
Automatic Available Split			√			
Automatic Callback	√	√	√	√		
Automatic Call Distribution	√	√	√	√	√	
Automatic Circuit Assurance	√	√	√			
Automatic Incoming Call Display	√	√	√	√		
ARS Partitioning	√	√	√		√	
Automatic Trunk Measurement System			√			
Automatic Wakeup	√	√	√	√		
Basic Call Management System (BCMS)	√	√	√		√	
Bridged Call Appearance Multi-Appearance Voice Terminal	√	√	√			
Bridged Call Appearance Single-Line Voice Terminal	√	√	√			
Busy Verification of Terminals and Trunks	√	√	√			
Bulk Station Administration			√			
Call-By-Call Service Selection	√	√	√	√	√	
Call Coverage	√	√	√			
Call Detail Recording (CDR)	√	√	√	√		
CDR Account Code Dialing	√	√	√			
CDR Variable Format Reports			√			
Call Forwarding All Calls	√	√	√			
Call Park	√	√	√			
Call Party Number/Billing Number	√	√	√	√	√	
Call Pickup	√	√	√			
Call Prompting		√	√	√	√	
Call Vectoring		√	√		√	
Call Waiting Termination	√	√	√			
Centralized Attendant Service (CAS) Branch	√	√	√	√	√	
CAS Main (Enhanced Systems Only)	√	√	√	√	√	
Class of Restriction	√	√	√			
Class of Service	√	√	√			
Code Calling Access	√	√	√	√		
Conference—Attendant	√	√	√			
Conference—Terminal	√	√	√			
Consult	√	√	√			
Coverage Callback	√	√	√			
Coverage Incoming Call Identification	√	√	√			
Customer-Provided Equipment (CPE) Alarm*	√	√	√			
D-Channel Backup		√	√	√		
Data Call Setup	√	√	√	√		
Data Hot Line	√	√	√			
Data-Only Off-Premises Extensions	√	√	√	√		
Data Privacy	√	√	√			
Data Restriction	√	√	√			

**TABLE A (continued).  
Feature Determination**

Feature	G1	G3i	G3r	Additional Hardware Required	Additional Software Required	Desired
DCS Alphanumeric Display for Terminals	√	√	√	√	√	
DCS Attendant Control of Trunk Group Access	√	√	√	√	√	
DCS Attendant Direct Trunk Group Selection	√	√	√	√	√	
DCS Attendant Display	√	√	√	√	√	
DCS Automatic Callback	√	√	√	√	√	
DCS Automatic Circuit Assurance	√	√	√	√	√	
DCS Busy Verification of Terminals and Trunks	√	√	√	√	√	
DCS Call Forwarding All Calls	√	√	√	√	√	
DCS Call Waiting	√	√	√	√	√	
DCS Distinctive Ringing	√	√	√	√	√	
DCS Leave Word Calling	√	√	√	√	√	
DCS Multi-Appearance Conference/Transfer	√	√	√	√	√	
DCS Trunk Group Busy/Warning Indication	√	√	√	√	√	
Default Dialing		√	√	√		
Dial Access to Attendant	√	√	√			
Dial Plan	√	√	√			
Dialed Number Identification Service (DNIS)	√	√	√	√		
Digital Multiplexed Interface (DMI)	√	√	√	√		
Direct Department Calling (DDC) and Uniform Call Distribution (UCD)	√	√	√	√		
Direct Inward Dialing (DID)	√	√	√	√		
Direct Outward Dialing (DOD)	√	√	√	√		
Distinctive Ringing	√	√	√			
Do Not Disturb	√	√	√	√		
DS1 Tie Trunk Service	√	√	√	√		
EIA Interface	√	√	√	√		
Emergency Access to the Attendant	√	√	√			
Enhanced Trunk Signaling and Error Recovery			√			
Facility Busy Indication	√	√	√			
Facility Restriction Levels and Traveling Class Marks	√	√	√		√	
Facility Test Calls	√	√	√			
Forced Entry of Account Codes	√	√	√		√	
Functional Scheduling Enhancements			√			
Generalized Route Selection	√	√	√			
Go To Cover	√	√	√			
Hold	√	√	√			
Hot Line Service	√	√	√			
Hunting	√	√	√			
Individual Attendant Access	√	√	√			
Information System Network (ISN) Interface	√	√	√	√		
Integrated Directory	√	√	√			
Integrated Services Digital Network -Basic Rate Interface (ISDN-BRI)		√	√	√		
Integrated Services Digital Network -Primary Rate Interface (ISDN-PRI)	√	√	√	√	√	

**TABLE A (continued).**  
**Feature Determination**

Feature	G1	G3i	G3r	Additional Hardware Required	Additional Software Required	Desired
Intercept Treatment	√	√	√	√		
Intercom—Automatic	√	√	√			
Intercom—Dial	√	√	√			
Inter-PBX Attendant Calls	√	√	√	√		
Intraflow and Interflow	√	√	√		√	
Last Number Dialed	√	√	√			
Leave Word Calling	√	√	√			
Line Lockout	√	√	√			
Loudspeaker Paging Access	√	√	√	√		
Loudspeaker Paging Access—Deluxe	√	√	√	√		
M-to-N Digit Conversion		√	√		√	
Main/Satellite Extended Trunk Access			√			
Malicious Call Trace			√			
Manual Message Waiting	√	√	√			
Manual Originating Line Service	√	√	√			
Manual Signaling	√	√	√			
Modem Pooling	√	√	√	√		
Move Agent From Call Management System (CMS)	√	√	√	√	√	
Multi-Appearance Preselection and Preference	√	√	√			
Multiple Listed Directory Numbers	√	√	√			
Multi-User System Management Access			√			
Music-on-Hold Access	√	√	√	√		
Names Registration	√	√	√	√		
Network Access—Private	√	√	√	√		
Network Access—Public	√	√	√	√		
Night Service—Hunt Group	√	√	√			
Night Service—Night Console Service	√	√	√			
Night Service—Night Station Service	√	√	√			
Night Service—Trunk Answer from Any Station	√	√	√	√		
Night Service—Trunk Group	√	√	√			
Off-Premises Station	√	√	√			
Outgoing Trunk-to-Outgoing Trunk Transfer			√			
PC/PBX Connection	√	√	√	√	√	
Permanent Switched Calls	√					
Personal Central Office Line (PCOL)	√	√	√	√		
Personalized Ringing	√	√	√			
Power Failure Transfer	√	√	√	√		
Priority Calling	√	√	√			
Privacy—Attendant Lockout	√	√	√			
Privacy—Manual Exclusion	√	√	√			
Property Management System (PMS)	√	√	√	√	√	
Queue Status Indications	√	√	√	√	√	
Recall Signaling	√	√	√	√		
Recent Change History	√	√	√			



**TABLE A (continued).**  
**Feature Determination**

Feature	G1	G3i	G3r	Additional Hardware Required	Additional Software Required	Desired
Recorded Announcement	√	√	√	√		
Recorded Telephone Dictation Access	√	√	√	√		
Remote Access	√	√	√	√		
Remote Administration	√	√	√	√		
Report Scheduler and System Printer	√	√	√	√	√	
Restriction—Controlled	√	√	√			
Restriction—Miscellaneous Terminal	√	√	√			
Restriction—Miscellaneous Trunk	√	√	√			
Restriction—Toll/Code	√	√	√			
Restriction—Voice Terminal	√	√	√			
Ringback Queuing	√	√	√			
Ringer Cutoff	√	√	√			
Rotary Dialing	√	√	√			
Send All Calls	√	√	√			
Senderized Operation	√	√	√			
Service Observing	√	√	√		√	
Single-Digit Dialing and Mixed Station Numbering	√	√	√			
Station Identification/Automatic Number Identification	√	√	√	√	√	
Straightforward Outward Completion	√	√	√			
Subnet Trunking	√	√	√	√	√	
System Measurements	√	√	√			
System Reload Indication			√			
System Status Report	√	√	√			
Temporary Bridged Appearance	√	√	√			
Ten-Digit to Seven-Digit Conversion	√				√	
Terminal Translation Initialization			√			
Terminating Extension Group	√	√	√			
Through Dialing	√	√	√			
Time of Day Routing	√	√	√		√	
Timed Reminder	√	√	√			
Touch-Tone Dialing	√	√	√			
Transfer	√	√	√			
Trunk Group Busy/Warning Indicators to Attendant	√	√	√			
Trunk Identification By Attendant	√	√	√			
Trunk-to-Trunk Transfer	√	√	√			
Unrestricted 5-Digit Uniform Dial Plan			√			
Uniform Call Distribution (UCD)	√	√	√			
Uniform Dial Plan (UDP)	√	√	√		√	
Vector Directory Number (VDN) Reports			√			
Voice Message Retrieval	√	√	√	√		
Voice Terminal Display	√	√	√	√		

## Features That Require Additional Hardware and/or Software

Table B lists the features that require additional hardware and/or software. Please note that additional hardware and/or software is not required in all cases. For example, if the special “wait” character is used extensively with the Abbreviated Dialing feature, additional tone detectors may be needed, but if the “wait” character is not used, additional detectors may not be required. (The “wait” character ties up the detector through the “wait” period.)

If you are planning to use a feature that requires additional hardware or software, list the hardware and/or software in Table B.

Unless otherwise noted, the features listed in Table B are available in all versions of the system.

**TABLE B. Features Requiring Additional Hardware and/or Software**

Feature	Hardware and/or Software Required	Actual Hardware and/or Software Needed
Abandoned Call Search	TN747 CO Trunk circuit pack.	
Abbreviated Dialing	Additional TN748 tone detectors are required if the special “wait” character is used frequently. Systems can have optional software to provide an enhanced Abbreviated Dialing list with an additional 1000 entries.	
CallVisor Adjunct Switch Application Interface (ASAI)	Requires a port on a TN556 ISDN-BRI circuit pack (12 ports) and a terminating resistor for each interface to be provided. Up to eight interfaces are supported. A TN778 Packet Control circuit pack is required for CallVisor ASAI applications. A TN771 Maintenance circuit pack is required in each port network of a duplicated CallVisor ASAI configuration.  Requires CallVisor ASAI software.*	

\* Software is activated by enabling this feature on the System Parameters Customer Options form.

**TABLE B (continued).**  
**Features Requiring Additional Hardware and/or Software**

Feature	Hardware and/or Software Required	Actual Hardware and/or Software Needed
Administered Connection/Access Endpoint	<p>Trunk Circuits: For G1 or G3i, TN767 DS1 Interface, TN760 Tie Trunk, or, for G3r and G1.2SE, TN464 Universal DS1 circuit pack.</p> <p>Other circuit packs: TN726 Data Line, or TN754 Digital Line, TN556 ISDN-BRI Line, TN758 Pooled Modem.</p> <p>Data Modules: MPDM, MTDM, 7400D series voice terminal with DTDM, 7400B, 7500B.</p>	
Agent Call Handling	ACD software.	
Attendant Direct Extension Selection With Busy Lamp Field	A selector console.	
Audio Information Exchange (AUDIX) Interface	<p>Distributed Communications System (DCS) software if AUDIX is desired in a DCS arrangement.* An AUDIX machine and an appropriate number of ports on a TN746 Analog circuit pack. AUDIX data link hardware is required as follows:</p> <p><b>Systems connected to AUDIX-L</b> PI jack on the TN765 Processor Interface circuit pack and an MPDM. If the PI jack is in use for another adjunct, one port on a TN754 Digital Line, an MTDM, and an MPDM are required for G1 or G3i. G3r requires the TN577 Packet Gateway and an isolating data interface (IDI).</p> <p><b>System connected to AUDIX-S or AUDIX-M</b> PI jack on the TN765 Processor Interface circuit pack. If the PI jack is in use for another adjunct, one port on a TN754 Digital Line circuit pack and an MPDM are required for G1 and G3i. G3r requires the TN577 Packet Gateway and an isolating data interface (IDI).</p>	

\* Software is activated by enabling this feature on the System Parameters Customer Options form.

**TABLE B (continued).**  
**Features Requiring Additional Hardware and/or Software**

Feature	Hardware and/or Software Required	Actual Hardware and/or Software Needed
Authorization Codes	Authorization Codes software. For outgoing calls, ARS or AAR software.	
Automatic Alternate Routing (AAR)	Private Networking software.	
Automatic Call Distribution (ACD)	<p>One port on a TN746 Analog Line circuit pack per auxiliary queue warning level lamp.</p> <p>Each analog announcement requires announcement equipment and one port on a TN746 Analog Line circuit pack. Each announcement, accessed by a call, requires one port on a TN750 Announcement circuit pack.</p> <p>If music is to be heard after the delay announcement, a music source and a port on a TN763 Auxiliary Trunk circuit pack is required.</p> <p>Appropriate voice terminals are required for agents. 2500-type sets are not recommended.</p> <p>ACD software is required.*</p>	
Automatic Incoming Call Display	A display-equipped voice terminal, or a voice terminal capable of displaying information through an attached data terminal. The terminals require a PRI or DCS link; otherwise they are station to station only.	
Automatic Route Selection (ARS)	ARS software and ARS Digit Conversion.*	
Automatic Route Selection (ARS) Partitioning	Additional TN748 tone detectors.	

\* Software is activated by enabling this feature on the System Parameters Customer Options form.

**TABLE B (continued).**  
**Features Requiring Additional Hardware and/or Software**

Feature	Hardware and/or Software Required	Actual Hardware and/or Software Needed
Automatic Wakeup	<p>If voice prompting is used, a TN725 Voice Synthesizer circuit pack is required. Each circuit pack has four ports to provide voice prompting. If voice synthesis announcements are used, two ports must be reserved for announcements.</p> <p>For customized recorded announcements, a model HQD614B Recorder/ Announcer manufactured by the Audichron® Company is required. This equipment requires a 48-volt power supply. Each Recorder/ Announcer requires four auxiliary trunk ports on the TN763 Auxiliary Trunk circuit pack.</p>	
Basic Call Management System (BCMS)	BCMS Measurements software.*	
Call-By-Call Service Selection	<p>For G1 or G3i, a TN767 DS1 circuit pack, TN768 Tone Clock circuit pack, and a TN765 Processor Interface circuit pack. For G3r, a TN464 Universal DS1 circuit pack, TN768 Tone Clock, and a TN553 Packet Data circuit pack.</p> <p>Requires ARS software and ISDN-PRI software.*</p>	
Call Detail Recording (CDR)	<p>Hardware requirements depend on the type of output device used for CDR. For G3i, the CDR output device can be connected directly to the Processor circuit pack (TN759 or TN773) which provides a standard EIA-232C interface. This eliminates the need for a data module as described for the output devices given below. For G3r, the CDR output device is connected to a TN553 Packet Data circuit pack, which is connected to a TN726 Data Line circuit pack.</p>	

\* Software is activated by enabling this feature on the System Parameters Customer Options form.

**TABLE B (continued).**  
**Features Requiring Additional Hardware and/or Software**

Feature	Hardware and/or Software Required	Actual Hardware and/or Software Needed
Call Detail Recording (CDR) <i>(continued)</i>	<p>A printer, personal computer, tape unit, or the TELESEER® CDR unit (Data Terminal Equipment)—a Modular Processor Data Module (MPDM) to a port on a TN754 Digital Line circuit pack or a 212A-type modem to a port on a TN746 Analog Line circuit pack. In the latter case, a standard pooled modem is required for the data path.</p> <p>94A Local Storage Unit (LSU) (Digital Communications Equipment) (G1 Only)—a MTDM to a port on a TN754 Digital Line circuit pack or a 212A-type modem to a port on a TN746 Analog Line circuit pack. In the latter case, a pooled modem is also required.</p> <p>Host computer—A private line terminated at the DEFINITY Generic 1 with a Trunk Data Module. Also, a private line modem if off-premises (out-of-building).</p> <p>A TN726 Data Line circuit pack can be used in conjunction with an Asynchronous Data Unit (ADU) to connect a 94A LSU, TELESEER CDR unit, or printer.</p> <p>Older equipment may not support enhancements to World Class Routing (International DEFINITY). Use Call Accounting System Plus for full functionality in such cases.</p>	

\* Software is activated by enabling this feature on the System Parameters Customer Options form.

**TABLE B (continued).**  
**Features Requiring Additional Hardware and/or Software**

Feature	Hardware and/or Software Required	Actual Hardware and/or Software Needed
Call Prompting	Each Call Prompting announcement requires a port on a TN750 Announcement circuit pack or an external announcement facility (analog announcements). Note that each announcement requires a port on a TN746 Analog Line circuit pack. The TN744 Call Classifier circuit pack is required to provide touch-tone receivers for use by the feature. Up to ten TN744s may be assigned. Each TN744 provides eight touch-tone receivers and requires Call Vectoring Basic and Call Prompting software.	
Call Vectoring	If music source is required (recommended), refer to the Music-On-Hold feature for hardware requirements.  Requires Vectoring—Basic. Vectoring—Prompting software is optional.*	
Call Party Number/Billing Number	Interface via the CallVisor ISDN Gateway Adjunct—refer to the Station Identification/Automatic Number Identification requirement for hardware requirements.  Requires ISDN-PRI software and CallVisor ISDN Gateway software.*	
Centralized Attendant Service (CAS) (Branch or Main)	For G1 or G3i, TN760 Tie Trunk or TN767 DS1 Interface circuit pack. For G3r or International DEFINITY, use TN464 Universal DS1 circuit pack instead of TN760 or TN767. The TN760 will also serve all other tie trunk applications. As an alternative, the TN722 DS1 Tie Trunk circuit pack can be used for the release link trunks of the CAS network. CAS Main or Branch software is required.	

\* Software is activated by enabling this feature on the System Parameters Customer Options form.

**TABLE B (continued).  
Features Requiring Additional Hardware and/or Software**

Feature	Hardware and/or Software Required	Actual Hardware and/or Software Needed
Code Calling Access	Loudspeaker paging equipment and one port on a TN763 Auxiliary Trunk circuit pack per zone. (These hardware requirements can be shared with the Loudspeaker Paging Access feature.)	
D-Channel Backup	Requires DS1 and ISDN-PRI facilities. Refer to ISDN-PRI for associated hardware and software requirements. Note that TN767 DS1 circuit pack does not provide DS0. TN464 Universal DS1 circuit pack does provide DS0.	
Data Call Setup	<p>Each data module requires one port on a TN754 Digital Line circuit pack. [A Digital Terminal Data Module (DTDM) shares the port with the associated voice terminal.]</p> <p>Each AT&amp;T 510D or 515 BCT requires one port on a TN754 Digital Line circuit pack for shared use of voice and data.</p> <p>Each digital voice terminal requires one port on a TN754 Digital Line circuit pack for shared use of voice and data.</p> <p>Each modem requires one port on a TN746 Analog Line circuit pack.</p> <p>For modem pooling, requires either a TN758 Modem Pool circuit pack (two conversion resources per board) or one digital port with a Trunk Data Module or Modular Trunk Data Module (MTDM), and one analog port with an analog modem for each conversion resource.</p>	



**TABLE B (continued).**  
**Features Requiring Additional Hardware and/or Software**

Feature	Hardware and/or Software Required	Actual Hardware and/or Software Needed
Data Call Setup <i>continued</i>	<p>Keyboard Dialing to off-premises (out of building) data endpoints requires the use of a TN748 Tone Detector circuit pack.</p> <p>Extensive use of features and services using tone detection may require additional TN748 circuit packs (several other features also use a TN748).</p>	
Data-Only Off-Premises Extensions	A Trunk Data Module and one port on a TN754 Digital Line circuit pack.	
Distributed Communications System (DCS) Features	For G1 or G3i, the TN765 Processor Interface circuit pack is required. For G3r, the TN553 Packet Data circuit pack is required. DCS software and ISDN-BRI or ISDN-PRI software are required for DCS features.*	
Dialed Number Identification Service (DNIS)	For non ISDN-PRI type calls, requires a port on a TN722/ TN760/TN767/TN464 DS1 group to support MEGACOM® 800 DNIS or a port on a TN753 DID Trunk Group. Also requires display-equipped answering voice terminals.	
Digital Multiplexed Interface (DMI)	For G1 or G3i, one TN722 or TN767 DS1 circuit pack per 24 DMI trunks. For G3r, one TN464 per 24 DMI trunks.	
Direct Department Calling (DDC) and Uniform Call Distribution (UCD)	<p>One port on a TN746 Analog Line circuit pack per queue warning level lamp, if needed.</p> <p>Announcement equipment and one port on a TN746 Analog Line circuit pack per analog delay announcement. If music is to be heard after the delay announcement, a music source and a port on a TN763 Auxiliary Trunk circuit pack is required. A TN750 Announcement circuit pack can be used to provide up to 64 different announcements.</p>	

\* Software is activated by enabling this feature on the System Parameters Customer Options form.

**TABLE B (continued).**  
**Features Requiring Additional Hardware and/or Software**

Feature	Hardware and/or Software Required	Actual Hardware and/or Software Needed
Direct Inward Dialing (DID)	One port on a TN753 DID Trunk circuit pack or TN722/TN767/ TN464 DS1 circuit pack for each DID trunk.	
Direct Outward Dialing (DOD)	One port on a TN747 Central Office (CO) Trunk circuit pack or TN722/TN767/TN464 DS1 circuit pack for each assigned trunk.	
Do Not Disturb	If voice prompting is used, a TN725 Voice Synthesizer circuit pack. Each circuit pack has four ports.	
DS1 Tie Trunk Service	For G1 or G3i, one TN722 or TN767 DS1 circuit pack per 24 Voice-Grade DS1 tie trunks required or per 23 Alternate Voice Data (AVD) DS1 tie trunks. For G3r or International DEFINITY, one TN464 Universal DS1 circuit pack required per 24 Voice-Grade DS1 tie trunks or per 23 AVD DS1 tie trunks. A TN768 Tone Clock must also be used.	
EIA Interface	One TN726 Data Line circuit pack per eight EIA interfaces. One Asynchronous Data Unit (ADU) per port on the circuit pack.	
Emergency Access to Attendant	Emergency Access to Attendant software.*	
Facility Restriction Levels (FRLs) and Traveling Class Marks (TCMs)	FRLs—ARS and/or Private Networking software* TCMs—Private Networking software and intertandem tie trunks.*	
Forced Entry of Account Codes	Forced Entry of Account Codes software.*	
Generalized Route Selection	AAR, ARS, and ISDN-PRI services software.*	

\* Software is activated by enabling this feature on the System Parameters Customer Options form.

**TABLE B (continued).**  
**Features Requiring Additional Hardware and/or Software**

Feature	Hardware and/or Software Required	Actual Hardware and/or Software Needed
Inbound Call Management (ICM)	<p>Requires CallVisor ASAI hardware (refer to the CallVisor ASAI feature for hardware requirements).</p> <p>Requires use of the ACD feature (refer to the ACD feature for hardware requirements).</p> <p>May use Call Prompting. Refer to the Call Prompting feature for hardware requirements.</p> <p>Requires CallVisor ASAI software.*</p>	
Information System Network (ISN) Interface	One TN726 Data Line circuit pack per eight ISN interfaces.	
Integrated Services Digital Network-Basic Rate Interface (ISDN-BRI)	<p>One TN556 ISDN-BRI circuit pack for up to 12 BRI (2B+D) endpoints using the 4-wire T interface. It also supports up to 24 endpoints in a passive bus arrangement. The circuit pack supports the frame relaying of ISDN Packet Mode data in either the D-channel or one of the B-channels, but G3i software will support only circuit switching of Mode 3 in the B-channel.</p> <p>For G3i, the system must be equipped with a Packet Control (TN778) circuit in order to support this circuit pack. For G3r, all TN776 Expansion Interface circuit packs must be replaced by TN570 Expansion Interface circuit packs.</p>	
Integrated Services Digital Network-Primary Rate Interface (ISDN-PRI)	For G1 or G3i, one TN767 DS1 Interface circuit pack for a signaling link and up to 23 ISDN-PRI trunk group members, and a TN765 Processor Interface circuit pack. For G3r, one TN464 Universal DS1 circuit pack for a signaling link and up to 23 ISDN-PRI trunk group members, and a TN765 Processor Interface circuit pack. ISDN-PRI software and ARS software are required.	

\* Software is activated by enabling this feature on the System Parameters Customer Options form.

**TABLE B (continued).**  
**Features Requiring Additional Hardware and/or Software**

Feature	Hardware and/or Software Required	Actual Hardware and/or Software Needed
Intercept Treatment	Announcement equipment and one port on a TN746 Analog Line circuit pack per analog announcement. A TN750 Announcement circuit pack can provide up to 64 different announcements, which can be recorded directly onto the TN750 circuit pack.	
Inter-PBX Attendant Calls	A tie trunk group between the branch and main locations. CAS software (Main or Branch) is required.	
Intraflow and Interflow	ACD software.	
Lookahead Interflow	Requires an ISDN-PRI interface (see ISDN-PRI feature for hardware requirements). Requires Lookahead Interflow software, Private Networking Automatic Alternate Routing (PNA) software, and Call Vectoring software.*	
Loudspeaker Paging Access	Loudspeaker paging equipment and one port on a TN763 Auxiliary Trunk circuit pack per zone. Paging interface equipment, consisting of a 278A Adapter (only if equipment is not FCC-registered) and a 24-volt power supply, per zone. (This hardware can be shared with the Code Calling Access feature.)  If PagePac® paging system equipment is used, one port on a TN747 CO Trunk circuit pack, TN746 Analog Line circuit pack, TN763 Auxiliary Trunk circuit pack (depending on the PagePac arrangement used).	
Loudspeaker Paging Access-Deluxe	See Loudspeaker Paging Access.	
M-to-N Digit Conversion (G3)	Either ARS and Private Networking software or ARS and UDP software.	

\* Software is activated by enabling this feature on the System Parameters Customer Options form.

**TABLE B (continued).**  
**Features Requiring Additional Hardware and/or Software**

Feature	Hardware and/or Software Required	Actual Hardware and/or Software Needed
Modem Pooling	One TN758 Pooled Modem circuit pack per two integrated conversion resources provided. Each combined conversion resource requires one port on the Digital Line circuit pack and one port on an Analog Line circuit pack, along with an analog modem and MTDM or 7400A Data Module.	
Move Agents From Call Management System (CMS)	ACD software and a CMS.	
Music-on-Hold Access	A music source and one port on a TN763 Auxiliary Trunk circuit pack. Also, a 36A Voice Coupler if the system is not FCC-registered.	
Names Registration	See Property Management System (PMS) feature for hardware requirements.	
Network Access—Private	One port on a TN760, TN722 DS1, TN767, or TN464 DS1 circuit pack for each trunk assigned.	
Network Access—Public	One port on a TN760, TN722 DS1, TN767, or TN464 DS1 Tie Trunk circuit pack for each trunk assigned or one port on a TN747 CO Trunk circuit pack for each trunk assigned.	
Night Service—Trunk Answer From Any Station	A ringing device and one port on a TN746 Analog Line circuit pack.	
Off-Premises Station	Cross-connecting capabilities and one port on a TN746 Analog Line circuit pack or TN767 DS1 Interface circuit pack or TN464 Universal DS1 circuit pack.	
Personal Central Office Line (PCOL)	One port on a TN747 CO Trunk circuit pack or TN722/TN767/TN464 DS1 circuit pack for each CO, Foreign Exchange (FX), or WATS trunk assigned as a PCOL.	

**TABLE B (continued).**  
**Features Requiring Additional Hardware and/or Software**

Feature	Hardware and/or Software Required	Actual Hardware and/or Software Needed
Power Failure Transfer	<p>One emergency transfer panel per five or six trunks assigned to Power Failure Transfer, depending on which of the two panels is used.</p> <ul style="list-style-type: none"> <li>• 808A Panel—Serves up to five power failure transfer terminals. Provides automatic ground start or loop start and “restore after busy” feature.</li> <li>• PORTA SYSTEMS® Model 574-5 Panel—Serves up to five power failure transfer terminals. Provides automatic ground start or loop start.</li> </ul>	
Property Management System (PMS)	<p>Either a TN726 Data Line circuit pack with an ADU or a data module and port on a TN754 Digital Line circuit pack. Printer required.</p>	
Queue Status Indication	<p>One port on a TN746 Analog Line circuit pack for each auxiliary queue warning lamp (such as a 21C-49).</p> <p>Requires ACD software.</p>	
Recorded Announcement	<p>Announcements can be either analog or integrated. Each analog announcement requires announcement equipment (Cook Electric 213300 Single Channel or Cook Electric 213400 Multi-Channel) and one port on a TN746 Analog Line circuit pack. For customized recorded announcements, a model HQD614B Recorder/Announcer manufactured by the Audichron Company can be used. Each integrated announcement, accessed by a call, requires one port on a TN750 Announcement circuit pack. Up to 64 announcements can be recorded on the TN750.</p>	

**TABLE B (continued).**  
**Features Requiring Additional Hardware and/or Software**

Feature	Hardware and/or Software Required	Actual Hardware and/or Software Needed
Recorded Telephone Dictation Access	Telephone dictation machines and, depending on the type of machine, one port on a TN746 Analog Line circuit pack or one port on a TN763 Auxiliary Trunk circuit pack for each machine assigned.	
Remote Access	Dedicated trunks, if Remote Access is not available via DID.	
Report Scheduler and System Printer	<p>G3r requires a system port comprising a TN553 Packet Data circuit pack connected to a TN726 Data Line circuit pack. For G1, G3i, and G3r, other hardware requirements depend on the type of interface used for the system printer (dedicated for the Report Scheduler feature). The printer may be an AT&amp;T 470- or 570-series printer, which uses a serial interface, or a compatible printer. A Personal Computer (PC) may be connected to the system printer port for collection of data; however, a serial interface on the PC must be provided for the connection. The system printer can be connected as follows:</p> <ul style="list-style-type: none"> <li>• Using the Data Communications Equipment (DCE) jack on the back of the Control Cabinet which provides a standard EAI-232C interface. This eliminates the need for a data module. An appropriate 50-foot cable is required.</li> <li>• Using a TN754 Digital Line port and a data module.</li> <li>• Using a TN726 Data Line port and an ADU.</li> </ul>	
Ringer Cutoff	Requires multi-appearance voice terminals.	

**TABLE B (continued).**  
**Features Requiring Additional Hardware and/or Software**

Feature	Hardware and/or Software Required	Actual Hardware and/or Software Needed
Station Identification/ Automatic Number Identif- ication (SID/ANI) (G1 name) Calling Party Number/Billing Number (CPN/BN) (G3)	<p>For G1 or G3i, assign an Interface Link (requires a TN765 Processor Interface circuit pack) for a direct EIA-232 connection (if not already used). Alternately, a data module and TN754 Digital Line port (for G1 and G3i) can be used. For G3r or G1.2SE, TN464 Universal DS1 circuit pack (for G3r or G1.2SE) is used. Note that the link is administered on the System's Processor Channel Assignments form. The link is used as an interface to a CallVisor ISDN Gateway adjunct (3B2 Processor) in support of SID/ANI (G1) or CPN/BN (G3). Requires display terminals.</p> <p>Requires ACD-related hardware also. Refer to the ACD feature coverage elsewhere in this table.</p> <p>Requires ISDN-PRI software and CallVisor ISDN Gateway software.*</p>	
Service Observing	Requires Service Observing Software.*	
Subnet Trunking	<p>Additional TN748 circuit packs, if Routing Patterns containing "wait" symbols are used heavily, and if dial tone detection is preferable to waiting for interval time-out.</p> <p>Private Networking, UDP, or ARS software. DCS software is optional.</p>	
Ten-Digit to Seven-Digit Conversion (G1 Only)	Either ARS and Private Networking software or ARS and UDP software.	
Time of Day Routing	Time of Day Routing software. ARS software.	
Uniform Dial Plan (UDP)	UDP software.	

\* Software is activated by enabling this feature on the System Parameters Customer Options form.



**TABLE B (continued).**  
**Features Requiring Additional Hardware and/or Software**

<b>Feature</b>	<b>Hardware and/or Software Required</b>	<b>Actual Hardware and/or Software Needed</b>
Voice Message Retrieval	A TN725 Speech Synthesizer circuit pack. Each circuit pack has four ports to provide Voice Message Retrieval. Traffic Engineering is required to determine the number of circuit packs.	
Voice Terminal Display	A display-equipped voice terminal and one port on a TN754 Digital Line circuit pack or TN556 ISDN-BRI circuit pack.	

## SYSTEM PARAMETERS

Table C provides information on the overall capacities of the system. The numbers shown in the table are maximum limits for each of the items listed. This information, plus the information in Table A, can be used to determine which version of the system to order.

Additional information associated with the features listed in Table C is available in the *DEFINITY® Communications System Generic 1 and Generic 3—Feature Description*, 555-230-201.

**Note:** One additional parameter of the G3r system that is not noted in the table is distance. Please note that there is a maximum 100-mile end-to-end circuit distance between any two DS1 remoted EPNs. That is, if two EPNs are DS1, the sum of the total circuit distance cannot exceed 100 miles. For example, if one EPN is 75 circuit miles from the Center Stage Switch (CSS), a second EPN cannot be more than 25 circuit miles away from the CSS.

**TABLE C. System Parameters**

Item	G1	G3i	G3r
Abbreviated Dialing (AD)			
AD lists per system	1,600	1,600	5,000
AD list entry size	24	24	24
AD entries per system	8,000	10,000	25,000
Personal Lists	1,600	1,600	5,000
Max. entries	10	10	10
Per extension	3	3	3
Group Lists	100	100	1,000
Max. entries	90	90	90
Per extension	3	3	3
System Lists	1	1	1
Max. entries	90	90	90
Enhanced Lists	1	1	1
Max. entries	1,000	1,000	1,000
Alphanumeric Dialing	No	Yes	Yes
Max. entries	None	200	1,250

**TABLE C (continued).**  
**System Parameters**

Item	G1	G3i	G3r
Applications Adjuncts			
BX.25 Links: Single-Carrier Cabinet (SCC)/			
Multi-Carrier Cabinet (MCC)	4/8	4/8	16
application processors [3B2 Message Center Service (MCS), etc.]	1	1	7
AUDIX adjuncts	1	1	5
CMS adjuncts	1	1	1
ICM adjuncts	None	1	1
CallVisor ISDN Gateway	1	1	1
Message Service Adjuncts (MSA)	1	1	1
CallVisor ASAI Adjuncts	None	8	8
Asynchronous Links (EIA-232)	5	5	10
CDR output devices	2	2	2
Journal printer	2	2	2
System printer	2	2	2
Property Management System (PMS)	1	1	1
BX.25 Processor Channels	64	64	128
Hop Channels	64	64	128
Attendant Service			
Attendant positions (day/night)	6/1	6/1	27/1
Switched loops/consoles	6	6	6
Attendant control restriction groups	64	64	96
100's groups/attendant console	20	20	20
Queue length	30	30	300
Emergency access queue length	50	50	80
Other access queues			
Maximum number of queues	1	1	12
Maximum number of queue slots	50	50	80
Size range of reserved queue	None	2-75	2-75
Reserved queue default size	None	5	5
Centralized Attendant Service (CAS)			
Release link trunk groups at branch	1	1	1
Release link trunks at branch	99	99	99
Release link trunk groups at main	99	99	99
Release link trunks at main	400	400	4,000
Branches per main	99	99	99

**TABLE C (continued).**  
**System Parameters**

Item	G1	G3i	G3r
ARS/AAR			
AAR/ARS patterns	254	254	640
ARS patterns for measurement	20	20	25
Trunk groups in an ARS pattern	6	6	16
Entries in RNX table	640	None	None
Entries in FNPA table	200	None	None
Toll tables	32	32	32
RHNPA tables	32	32	32
UDP (entries)	240	240	50,000
Choices per RHNPA table	12	12	12
Entires in TOLL table	800	800	800
Entries in HNPA & RHNPA tables	800	1,000	1,000
FRLs	8	8	8
Inserted digit strings*	1,200	1,200	3,000
Digits inserted for ARS/AAR	36	36	36
Digits deleted for ARS/AAR	11	18	18
Routing plans	8	8	8
Time of Day (TOD) charts	8	8	8
ARS/AAR table entries (NPA, NXX, RXX, HNPA, FNPA)	None	2,000	2,000
Digit conversion entries	180	300	300
CallVisor ASAI			
Number of CallVisor ASAI links	None	8	8
Number of BX.25 Outbound Call Management (OCM) adjuncts	None	1	1
Notification requests	None	170	460
Simultaneous active adjunct controlled calls	None	300	3,000
Active controlling associations	None	2,000	3,000
Switch to adjunct associations	None	127	127
Extension controllers per station domain	None	2	2
Call controllers per call	None	1	1
Call monitors per call	None	1	1
Number of adjunct users	None	40	100
Maximum adjunct controlled agents	None	200	200
OCM agent move (maximum agents)	80	80	80

\* This is the number of available 12-character inserted-digit-strings available for AAR/ARS preferences.

**TABLE C (continued).**  
**System Parameters**

Item	G1	G3i	G3r
Authorization			
Classes of restriction	64	64	96
Classes of service	16	16	16
Authorization codes	5,000	5,000	90,000
Length of authorization code	4-7	4-7	4-7
Remote access barrier codes	10	10	10
Length of barrier code	4-7	4-7	4-7
Toll call lists	None	1	1
Restricted call lists	None	1	1
Account code digits	1-15	1-15	1-15
Unrestricted/allowed call lists	10	10	10
Total call list entries	1,000	1,000	1,000
Automatic Callback Calls	160	160	1,000
Automatic Wakeup			
Wakeup requests per system	1,600	1,600	10,000
Wakeup requests per extension	1	1	1
Wakeup requests per 15-minute interval	300	300	950
Advance wakeup request time:			
Hours	23	23	23
Minutes	55	55	55
Simultaneous display requests	10	10	10
BCMS			
Measured agents per system	30	200	200
Measured trunk groups	30	32	32
VDNs	None	512	512
Measured trunk group members	400	400	400
Reporting periods (30 min. or 60 min.)	25	25	25
Daily summary reports	7	7	7
Call Appearances			
Call appearances/station*	54	54	54
Bridged images/appearance	7	7	15
Total bridged appearances	1,600	1,600	10,000

\* The number of call appearances is the sum of primary and bridged appearances; at most 10 can be primary.

**TABLE C (continued).**  
**System Parameters**

Item	G1	G3i	G3r
Cabinets			
PPN			
MCC	1	1	1
Single-carrier control (basic)	1	1	None
Single-carrier control cabinet (duplicated)	2	2	None
Single-carrier port cabinet (basic)	3	3	None
Single-carrier port cabinet (duplicated)	2	2	None
EPN			
MCC	1	2	21
Single-carrier expansion control cabinet (basic)	1	2	20
Single-carrier expansion control cabinet (duplicated)	2	4	None
Single-carrier port cabinet (basic)	2	9	60
Single-carrier port cabinet (duplicated)	2	8	None
Inter-port network connectivity			
Port networks	2	3	22
Maximum number of port networks/cabinet	1	1	2
Switch nodes (simplex)	None	None	2
Switch nodes (duplicated)	None	None	4
DS1 converter complex (simplex)	None	None	20
DS1 converter complex (duplicated)	None	None	40
Call Coverage			
Coverage paths	600	600	5,000
With hospitality parameter reduction	5	5	None
Coverage points in a path	3	3	3
Coverage path lists	4	4	4
Coverage paths linked together	4	4	4
Coverage paths included in call coverage report	100	100	100
Coverage Answer Groups (CAGs)	200	200	500
Members per CAG	8	8	8
Max. users per coverage path	2,900	2,900	2,187
Call Detail Recording (CDR)			
Call Detail Recording Utility (CDRU) capacity (calls per hour)	10,000	10,000	40,000
Number of CDRUs per system	1	1	1
CDRU trackable extensions	1,600	1,600	10,000
Intra-switch call trackable extensions		100	500

**TABLE C (continued).  
System Parameters**

Item	G1	G3i	G3r
Call Forwarding			
Call forwarded numbers	1,600	1,600	10,000
Call forwarded digits	16	16	16
Call Park			
Number of parked calls	482	723	723
Attendant group common shared extension numbers	10	10	40
Call Pickup Groups			
Number of groups	800	800	5,000
With hospitality parameter reduction	5	5	None
Call pickup members per system	1,600	1,600	10,000
Call pickup members per group	50	50	50
Call Vectoring/Call Prompting			
Vectors per system	None	256	512
Vector directory numbers	None	500	3,000
Steps per vector	None	15	32
Priority levels	None	4	4
Multiple split queuing splits/call	None	3	3
Multiple splits for agent logins	None	3	4
Carriers in MCCs			
Control carrier in simplex system	1	1	1
Control carriers in duplicated system	2	2	2
Port carrier in simplex PPN cabinet	4	4	4
Port carrier in simplex CSS PPN cabinet	None	None	3
Port carrier in duplicated PPN cabinet	3	3	3
Port carrier in duplicated CSS PPN cabinet	None	None	2
Port carrier in fully duplicated CSS PPN cabinet	None	None	1
Expansion control carrier in EPN cabinet	1	1	1
Port carrier in EPN cabinet	4	4	4
Port carrier in simplex CSS EPN cabinets 2-16	None	None	4
Port carrier in simplex-duplicated processor CSS EPN cabinet 2 of 22	None	None	3
Port carrier in simplex-fully duplicated CSS EPN cabinet 2 of 22	None	None	2
Port carrier in simplex and duplicated CSS EPN cabinets 3-22	None	None	4
Switch node in simplex PPN cabinet	None	None	1
Switch node in duplicate processor PPN cabinet	None	None	1
Switch node in fully duplicated PPN cabinet	None	None	2

**TABLE C (continued).**  
**System Parameters**

Item	G1	G3i	G3r
Communication Interface Links			
MCC	8	8	8
SCC	4	4	4
Conference Parties	6	6	6
Simultaneous 3-way conference calls	483	483	3,542
Simultaneous 6-way conference calls	240	240	1,771
Data Parameters			
Access endpoints	None	400	5000
Administered connections*	18	128	128
Alphanumeric dialing	No	Yes	Yes
Maximum entries	None	200	600
Dial Plan			
Extensions	2,500	2,900	21,875
Number portability	None	None	Yes
Feature Dial access codes			
Number of access codes	70	70	70
Number of digits	1-3	1-3	1-4
Trunk dial access codes			
Number of access codes	197	197	1,331
Number of digits	1-4	1-4	1-4
Names			
Number of names	3,064	3,064	19,111
Number of characters in a name	15	15	15
Integrated directory entries	1,600	1,600	10,000
Minimum extension size	1	1	1
Maximum extension size	5	5	5
DID-listed directory numbers	8	8	20
Non-DID-listed directory numbers	50	50	666
Prefix extensions	Yes	Yes	Yes
Phantom extensions (admin. without hardware)		1,600	10,000
Digital Data Endpoints	800	800	5,000
Do Not Disturb (DND)			
DND requests per system (3)	1,600	1,600	10,000
Simultaneous display requests	10	10	30

\* These are permanent switched connections in G1.



**TABLE C (continued).  
System Parameters**

Item	G1	G3i	G3r
External CMS			
Measured agents per system	400	400	1,023
Measured agents per split	30	30	999
Measured splits	32	99	255
Measured trunk groups	99	99	666
Facility Busy Indicators			
Number of indicators	2,400	4,000	10,000
Buttons per tracked resource	100	100	100
Hunt Groups or Splits			
Groups and/or splits	99	99	255
With hospitality parameter reduction	5	5	None
Group members per system	500	500	3,000
Group members per group/split	200	200	999
Measured groups/splits	99	99	255
Queue slots per group	200	200	999
Queue slots per system	1,000	1,000	6,000
Announcements per group	2	2	2
Measured ACD agents			
Agents logged in per system measured by CMS	400	400	1,023
Agents logged in per split measured by CMS	200	200	999
ACD supervisors per system	99	99	255
Intercom Translation Table (ICOM)			
Automatic/manual and dial			
ICOM groups per system	32	32	680
Members per ICOM group	32	32	32
Members per system	1,024	1,024	8,192
Last Number Dialed			
Entries per system	2,400	2,400	15,028
Number of digits	16	16	16
Leave Word Calling (SPE based)			
Messages stored	2,000	2,000	2,000
Messages per user	10	10	16
Simultaneous message retrievers	60	60	400
Systemwide message retrievers	10	10	10
Remote message waiting indicators			
Per extension	80	80	80
Per system	80	80	500

**TABLE C (continued).**  
**System Parameters**

Item	G1	G3i	G3r
Modem Pool Groups			
Mode 2/analog	5	5	63
Members per group	32	32	32
Group members per system	160	160	2,016
Networking			
CAS nodes	99	99	99
DCS nodes	63	63	63
UDP nodes	240	240	1,000
Paging			
Loudspeaker zones	9	9	9
Code calling IDs	125	125	125
Personal CO Lines (PCOL)			
PCOL trunk groups	40	40	100
PCOL lines	40	40	100
PCOL trunks per trunk group	1	1	1
PCOL appearances	4	4	16
Port Circuit Pack Slots*			
Per PPN			
MCC simplex	89	89	80
MCC duplicated	78	78	60
SCC simplex	64	64	None
SCC duplicated	56	56	None
Per EPN			
MCC simplex	99	99	99
MCC duplicated	98	98	98
SCC simplex	71	71	71
SCC duplicated	70	70	70
Power Failure Extensions			
Model 574-5 panel	35	35	

\* Only port slots are included in this count. There are 100 port slots per EPN cabinet, one of which is dedicated for the Tone/Clock board. There may be other service-related slots required which would further reduce the number of port slots available. In G3 carriers, a 21<sup>st</sup> slot may be equipped with auxiliary boards that do not require tip and ring connections.

**TABLE C (continued).**  
**System Parameters**

Item	G1	G3i	G3r
Recorded Announcements			
Recorded announcements	64	128	256
Analog queue slots per system	150	150	300
Analog queue slots per announcement	150	150	300
Integrated queue slots per system	50	50	300
Calls connected per announcement			
Integrated announcement or auxiliary trunk	255	255	255
Analog trunk	128	128	128
Integrated announcement circuit packs	1	1	1
Channels per integrated announcement circuit pack	16	16	16
Integrated announcement recording time (min.:seconds)			
16 KB recording	None	8:32	8:53
32 KB recording	4:16	256	256
Speech Synthesis Circuit Packs	6	6	40
Channels per speech circuit pack	4	4	4
System Administration			
Simultaneous administration sessions	3	5	8
Simultaneous administration commands	1	1	5
Simultaneous maintenance commands	1	1	3
Administration history file entries	250	250	2000
Printer queue size	50	50	50
Terminating Extension Groups (TEGs)			
TEGs	32	32	32
Users that may share a TEG	4	4	4

**TABLE C (continued).**  
**System Parameters**

Item	G1	G3i	G3r
Time Slots			
Total slots	1,024	1,536	11,264
Slots for voice and data	966	1,449	10,604
Simultaneous circuit-switched calls	482	723	5,291
Tone Classifiers			
Tone detector circuit packs	20	10	50
General purpose tone detectors	40	20	100
Touch-tone receivers	80	40	200
Call classifier circuit packs	10	10	25
Call progress touch-tone receivers (TTR)	80	80	200
TTR queue size	4	4	4
Trunks			
Trunks in system (also remote access)	400	400	4,000
With hospitality parameter reduction	50	50	None
Trunk members in a trunk group	99	99	255
Trunk groups in the system	99	99	666
Trunk group hourly measurements	None	None	75
Queue slots for trunks	198	198	1,332
Ringback queue slots	120	1000	1,000
DS1 circuit packs	30	30	166
PRI Interfaces (D-channels)			
MCC	8	8	166
SCC	4	4	
PRI Interfaces (B-channels)			
MCC	184	400	
SCC	92	400	
PRI Temporary Signaling Connections		656	
Call associated		400	
Non-call associated		256	
Voice Terminals			
Stations <sup>1</sup>	1,600	1,600	10,000
Associated data modules (DTDMs, etc.)	800	800	5,000
Digital stations <sup>2</sup>	1,600	1,600	10,000
ISDN-BRI stations <sup>3</sup>	None	1,000	5,000
Station button capacity (units)	547.2 K	547.2 K	4.12 M
Display Stations	1,600	1,600	10,000

1. This includes extensions administered without associated hardware.

2. All digital stations can be display stations.

3. All ISDN-BRI stations can be display stations.

### Notes:

1. Digital data endpoints terminate on a port of the switch. Up to 800 ports can terminate digital data endpoints. The remaining system ports are available for terminating digital voice terminals, trunks, etc.
2. For G3, the extensions are shared among the following applications: voice station, attendant, data endpoint, hunt group, recorded announcement, TEG, VDN, extension for failed automatic wakeup messages, attendant common shared extensions, code calling ID, and phantom extensions. (For example, it is possible to have 1600 stations plus 1300 phantom extensions, that is, administration without hardware). In addition, there is another internal dial plan limit: PCOL groups, common shared extensions, access endpoints, code calling IDs, Listed Directory Numbers (LDNs), hunt groups, announcements, and TEGs are limited to 860.
3. When more than 23 B-Channels for every one D-Channel are provisioned, Non-Facility Associated Signaling (NFAS) must be used.
4. Trunks and access endpoints (see Data Parameters in Table C entries for more on access endpoints) consume the same resource. The sum of trunks and access endpoints cannot exceed 400.
5. A fully equipped PPN cabinet and EPN cabinet without duplication (MCC system) has 184 port circuit pack slots available (after tone detectors and expansion interfaces have been added in). A system using all these slots for digital line circuit packs has a maximum physical digital line capacity of 1472 lines (184 slots x 8 ports per slot). Replacing one of the digital line circuit packs with a trunk circuit pack or a circuit pack other than a digital line circuit pack reduces the digital line capacity by 8 lines. Therefore, trunking and analog and hybrid terminal requirements must be considered in determining the actual maximum for each system. When the second EPN is added in a G3 system, 1600 digital terminals can be configured in the system.
6. A button module (function key module) is a portion of memory required to store button translations. Some digital voice terminals require no button modules while other terminals need one or more modules. Digital voice terminal button module and display requirements are given in the following table, "Station Allocation Characteristics." These button module and display requirements limit the number of digital voice terminals with more than 10 feature buttons and/or displays that can be connected to a system. In G3, memory units are allocated by the system to each terminal based on the number of buttons actually translated. The button module scheme is no longer used in G3. There are 547,000 memory units available in G3 for terminals.
7. The system automatically initiates phantom user calls without any dialing from a voice terminal. An automatic wakeup call is an example of a phantom user call.

The following table shows the button module requirements of different station configurations.

**TABLE D. Station Allocation Characteristics**

Station Type	Required Records (G1,G3)	Required Records and Button Units*
Analog set 500	S	S+62
Analog set 2500	S	S+62
Analog set 7101A	S	S+62
Analog set 8102	S	S+62
Analog set 8110	S	S+62
10MET set - 10 buttons	S	S+52
20MET set - 20 buttons	S + [B]	S+152
30MET set - 30 buttons	S + [B]	S+252
Hybrid set - 7303S	S	S+102
Hybrid set - 7305S	S + [B]	S+342
Hybrid set - 7309S	S	S+102
Digital set - 7401D	S	S+92
Digital set - 7401 Plus	S	S+92
Digital set - 7403D	S	S+102
Digital set - 7404D	S + M	S+62
Digital set - 7404D w/display	S + B + M	S+192
Digital set - 7405D	S + [B]	S+342
Digital set - 7405D w/display	S + B + [B]	S+472
Digital set - 7406D	S + [B]	S+282
Digital set - 7406D w/display	S + B + [B]	S+342
Digital set - 7406 Plus	S + [B]	S+282
Digital set - 7407D (w/display)	S + B + [B]	S+472
Digital set - 7407 Plus	S + B + [B]	S+472
Digital set - 7410D	S	S+102
Digital set - 7434D	S + [B]	S+342
Digital set - 7434D w/call coverage module	S + B + [B]	S+542
Digital set - 7434D w/display	S + 2B + [B]	S+472
602A1	S + B + [B]	S+342
PC	S + B + [B]	S+472
510BCT	S + B + [B] + M	S+322
515BCT	S + B + M	S+232

\*

- Assumes 3 call appearances per station in button 1-3 with all other available buttons assigned.
- For call appearances other than 3, adjust total units by the following:  

$$\text{adjustment} = (Nca - 3) * [(10 * Ndisp) + (6 * Nbri)]$$
 where: Nca=number of call appearance (assumes first Nca button is CA)  
 Ndisp=total number of display stations in system  
 Nbri=total number of BRI station in system

**TABLE D (continued).**  
**Station Allocation Characteristics**

Station Type	Required Records (G1,G3)	Required Records and Button Units*
Basic Attendant Console	A + 2B	A
Enhanced Attendant Console	A + 2B	A
Attendant Selector Console	A + 2B	A
Feature Module	[B]	240
Display	B	**
DTDM	M	M
MPDM/MTDM/7400A/7400B/7500B	M	M
Call Coverage Module	B	200
EIA (PI-Simplex)	M	M
CDR	M	M
Netcon Data Channel	2M	2M
Processor Interface Link	2M	2M
[ISDN sets for G3 only]		
ISDN-BRI UDM - 7500		M + I
ISDN-BRI set - 7505		S + I + 190
ISDN-BRI set - 7506 w/display		S + I + 250
ISDN-BRI set - 7507 w/display		S + I + 480
ISDN-BRI set - 8503T		S + I + 50

LEGEND:

Notation	Meaning	G1	G3
A	Attendant record	7	7
S	Basic station record	1600	1600
B	Large button module	1000	2000
M	Data module record	800	800
I	ISDN-BRI endpoint record	N/A	N/A
#	Button memory units	N/A	547200

\*

- Assumes 3 call appearances per station in button 1-3 with all other available buttons assigned.
- For call appearances other than 3, adjust total units by the following:  
 $adjustment = (Nca - 3) * [(10 * Ndisp) + (6 * Nbri)]$   
 where: Nca=number of call appearance (assumes first Nca button is CA)  
 Ndisp=total number of display stations in system  
 Nbri=total number of BRI station in system

\*\* For G3, the number of button memory units required for a display depends on the station type. The number of button memory units required for a display is indicated for each station type in the table above. Note that these values depend on the assumptions in the previous footnote. (Call appearances are only translated on buttons 1-3.)

**Notes:**

Regarding station allocation:

1. For G1, [B] is equivalent to B. For G3, [B] indicates large button modules that are allocated only when a button on that module is administered.
2. Any digital DCP station can add a 7400B, requiring one data module record.
3. A DTDM can be added to a 7403D or 7405D, requiring one data module record.
4. The 6504-T is administered as a 7505D and the 6508-T is administered as a 7507D (G3 only).
5. A data module (ADM-T) can be added to a 7505D, 7506D, or 7507D, requiring one data module record (G3 only).
6. The PC/ISDN is administered as a 7506D or 7507D with ADM (G3 only).
7. An ISDN-BRI endpoint record is required for each distinct ISDN-BRI endpoint. Thus each voice-only, data-only, or voice-data endpoint uses one of these records.



## SYSTEM VERSION DETERMINATION

From the information given in Tables A, C, and D, you should now be able to determine the system version needed. Check the version in one of the boxes provided.

**G1**    

**G3i**   

**G3r**

## HARDWARE AND SOFTWARE DETERMINATION

### Voice/Data Terminal Equipment Assignments

Use Table E to list the system users and their individual equipment needs. Blank columns are provided so that you can fill in the name, extension number, application (voice and/or data), type of terminal equipment, and adjunct(s) required for each user. A current phone directory and station survey may be helpful when filling in this table.

**Note:** Before entering the information in Table E, review the *DEFINITY® Communications System Generic 1 and System 75 and System 85—Terminals and Adjuncts—Reference, 555-015-201*, to strengthen your familiarity with the system's terminals and adjuncts.

### Voice/Data Terminal Totals

Using the information listed in Table C and Table E, complete Tables F and G to summarize your terminal and adjunct needs. As mentioned above, detailed information for each voice terminal and adjunct can be found in the *DEFINITY® Communications System Generic 1 and System 75 and System 85—Terminals and Adjuncts—Reference, 555-015-201*.

After completing Tables F and G, complete Table H to ensure that the identified equipment is within the maximum limits of the system.



**TABLE F. Voice/Data Terminal Quantities**

Type	Model	Quantity
<b>Orderable With G3</b>		
Single-Line Analog <sup>1</sup>	2500 Series	
	2500DMGC	
	2500YMGK	
	510A	
	7102A	
	8102	
	8110	
Multi-Appearance Hybrid	7303S <sup>2</sup>	
	7305S <sup>2</sup>	
Multi-Appearance Digital <sup>3</sup>	7401D	
	7403D <sup>2</sup>	
	7404D <sup>2</sup>	
	7405D <sup>2</sup>	
	7406D	
	7407D	
	7410D	
	7434D	
	7401 Plus	
	7406 Plus	
	7407D Enhanced	
	7407 Plus	
	7410 Plus	
	7444 Plus	
	CallMaster®	
ISDN-BRI <sup>3</sup>	7505	
	7506	
	7507	
	8503T	

1. When used as on-premises, out-of-building stations, lightning protection is required. A carbon block, a wide-gap gas tube, or an equivalent solid-state device is required at each end of the interbuilding cable.
2. When used as on-premises, out-of-building stations, lightning protection is required. An ITW LYNX protector (LP2-100-068) or 4C3S-75 protector is required at each end of the interbuilding cable.
3. These terminals are no longer orderable. They have been Manufacturer Discontinued.

**TABLE F (continued).**  
**Voice/Data Terminal Quantities**

Type	Model	Quantity
<b>Orderable With G3</b>		
Data Terminals (Including DEFINITY Manager I terminals or G3r-MTs)	510D	
	513 BCT	
	515 BCT	
	610 BCT	
	615 MT	
	715 BCS	
	4410	
	4425	
Attendant Consoles	Basic Console	
	Selector Console	
<b>Reusable From Earlier Systems</b>		
Single-Line Analog <sup>1</sup>	500	
	7101A	
	7103A Fixed Feature	
	7103A Programmable	
Multi-Appearance Hybrid	7303H	
	7305H01B	
	7305H02B	
	7305H03B	
	7309H	
Multi-Button Electronic Telephone (MET) Sets	10 Button	
	10 Button with Built-In Speakerphone	
	20 Button	
	30 Button	

1. When used as on-premises, out-of-building stations, lightning protection is required. A carbon block, a wide-gap gas tube, or an equivalent solid-state device is required at each end of the interbuilding cable.

**TABLE G. Adjunct Quantities and Voice Terminal Compatibility**

<b>Adjunct</b>	<b>Terminal</b>	<b>Function</b>	<b>Quantity</b>
Call Coverage Module, C401A*	7405D 7434D	Adds 20 call appearance/feature buttons	
Digital Display Module, D401A*	7405D 7434D	Displays call-related and personal service information	
Function Key Module, F401A	7405D	Adds 24 feature buttons	
Headset Adapter, 500A	7405D	Provides for connection and control of standard headset	
Headset Adapter, 502A	7303S 7305S	Provides for connection and control of standard headset	
Messaging Cartridge	7404D	Provides display of call-related and personal service information on data terminal screen	
Speakerphone, S101A	7405D	Provides hands-free calling	
Speakerphone, S102A	7303S 7305S	Provides hands-free calling	

\* Combined maximum of 500 in G1, 800 in G3i, and 5000 in G3r.

**Instructions**

Enter the quantities of terminal equipment to be used in Table H. **Both** totals must be less than the allowed maximums for each terminal type. For each item, enter the quantity in the blank space provided. If both spaces are blank, enter the quantity in each space where applicable.

**TABLE H. Terminal Equipment Limits**

Terminal Type	Quantity	
	Terminals	Enhanced Term/Modules*
500		XXXXXXXX
2500		XXXXXXXX
2500 DMGC With Message Waiting		XXXXXXXX
2500 YMGK With Message Waiting		XXXXXXXX
2554		XXXXXXXX
510A		XXXXXXXX
7101A		XXXXXXXX
7102A		XXXXXXXX
7103A		XXXXXXXX
7303S		XXXXXXXX
7305S		
7302H		XXXXXXXX
7303H		XXXXXXXX
7309H		XXXXXXXX
7401D		XXXXXXXX
7401 Plus		XXXXXXXX
7403D		XXXXXXXX
7404D (Without/with messaging cartridge)		XXXXXXXX
7405D		
7406D		
7406 Plus		
7407D		
7407D Enhanced		
7407 Plus		
7410D		XXXXXXXX
7410 Plus		XXXXXXXX
7434D		
7444 Plus		

\* See Table D for the number of button modules per terminal type. Enter the total button modules for each terminal type in the "Enhanced Term/Modules" column.

**TABLE H (continued).  
Terminal Equipment Limits**

Terminal Type	Quantity	
	Terminals	Enhanced Term/Modules*
7505		
7506		
7507		
8102		XXXXXXXX
8110		XXXXXXXX
8503T		
602A1 (CallMaster®)		
10 BTN MET		XXXXXXXX
20/30 BTN MET		
510D		
515 BCT		
610 BCT		XXXXXXXX
615 MT		XXXXXXXX
715 BCS		XXXXXXXX
Attendant Console(s)	XXXXXXXX	
TOTAL		
TOTAL SHOULD NOT EXCEED:		
All G1	Max. 1,600 Voice Terminals	Max. 1,000 Enhanced Term/Modules
All G3i	Max. 1,600 Voice Terminals	Max. 1,000 Enhanced Term/Modules
All G3r	Max. 10,000 Voice Terminals	Max. 5,000 Enhanced Term/Modules

Have either of the above limits been exceeded? Yes    No  
      
 If yes, reconfigure the system to fall within the above limits.

\* See Table D for the number of button modules per terminal type. Enter the total button modules for each terminal type in the "Enhanced Term/Modules" column.



## Data Communications Equipment

Use the following information to determine the data communications equipment requirements for your system. Various data communications configurations are described. The system supports wideband area networks; private and switched data networks; and local host, terminal, and personal computer communications. The information includes the following:

- Illustrations of the physical relationships between the switch and data network components (including terminals, modems, modules, protocol converters, and host computers)
- Descriptions of data communications equipment associated with the system (including CDR and data modules)
- Descriptions of data terminals supported in the system (including display terminals and printers)
- Descriptions of the data communications adjuncts that are supported.

After reviewing this section, develop a data communications layout. Record existing equipment first; then indicate changes and additions that are specific to the system equipment and arrangements.

Enter the quantities of the data equipment required for your system in Table I.

**TABLE I. Data Communications Equipment**

Equipment	Quantity
Asynchronous Data Units (ADUs)	
EIA Terminals	
EIA Host Computer Ports	
Modular Processor Data Modules (MPDMs)	
Modular Terminal Data Modules (MTDMs)	
7400A Data Module	
7400B Plus Data Module	
7500B Data Module	
Pooled Modems (Integrated)	
Pooled Modems (Combined)	
Non-Pooled Modems	
3270A Data Modules	
3270T Data Modules	
3270C Data Modules	
Printers	
Personal Computers	

### **CDR Output Devices and Connections**

The CDR output device can be one of the following:

- TELESEER CDR Unit
- 94A Local Storage Unit (LSU)
- Printer
- Host computer
- Customer-provided equipment such as a personal computer

CDR output devices are connected to DEFINITY Generic 1 or Generic 3 using:

- Modular Processor Data Modules (MPDMs)
- Modular Trunk Data Modules (MTDMs)
- Data Line circuit packs and ADUs
- Modems
- Direct EIA-232C interface provided by the TN773 Processor circuit pack (G3i only)

The two preferred methods for connecting CDR equipment to the system are:

- Data Line circuit pack
- Direct EIA-232C connection (G3i only)

These two methods cost less than MPDMs or DTDMs.

Figure 1 shows some of the ways the output devices can be connected.

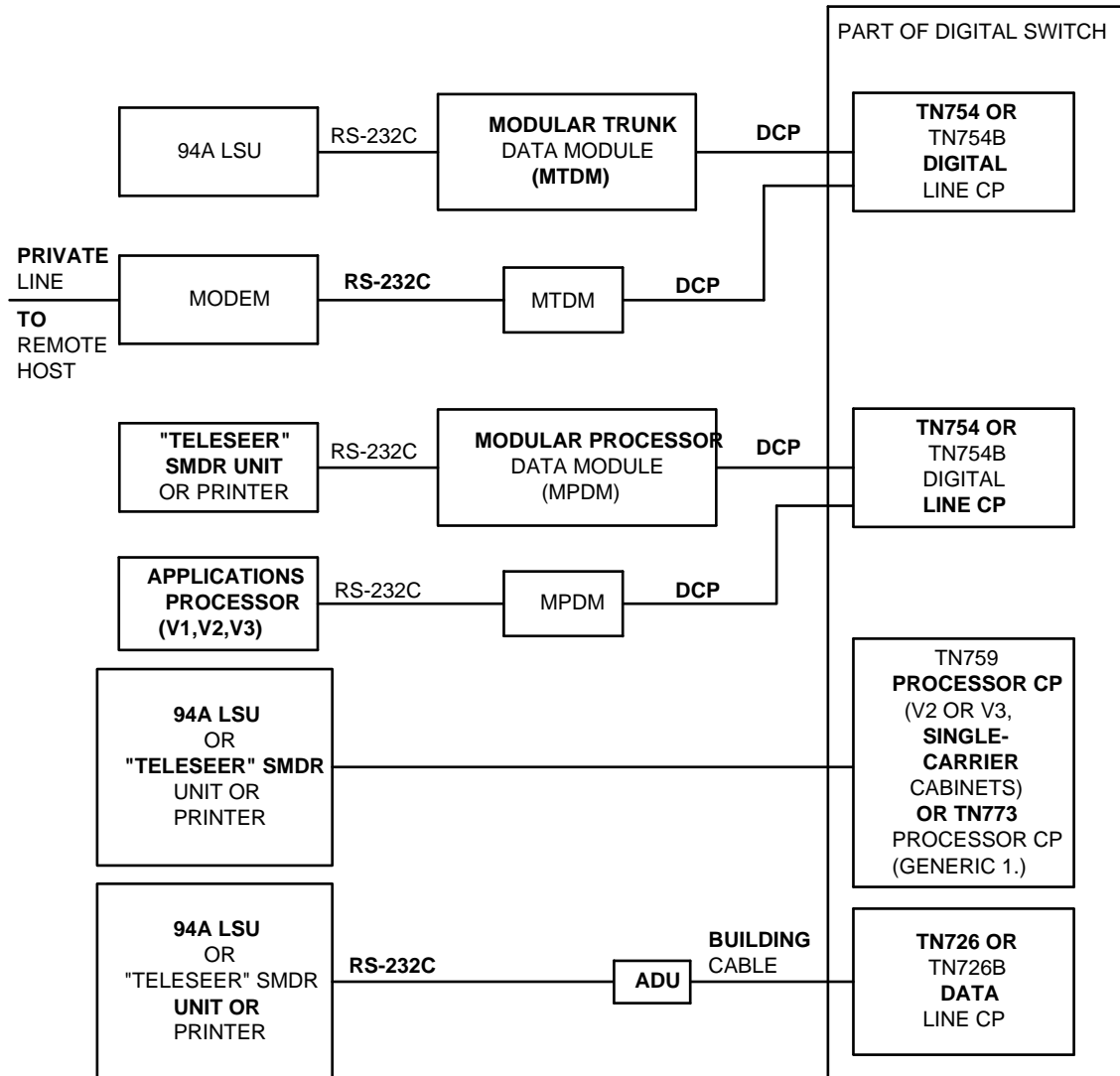

FIGURE 1. CDR Output Devices and Connections

## **Data Modules**

Data modules are communications devices that provide an interface between the digital switch, Data Terminal Equipment (DTE), and Data Communications Equipment (DCE). Data modules transmit and receive data, converting between the system's Digital Communications Protocol (DCP) and the following interfaces: EIA-232C, RS-366, RS-449, V.35, and a Category A coaxial interface.

Figure 2 shows some of the ways modules can be connected in a Local Data Endpoint configuration. Figure 3 shows some of the ways modules can be connected in a Remote Data Endpoint configuration.

To protect existing investments, in-place equipment that performs the same function as DEFINITY Generic 1 or Generic 3 data modules may be used.

The following system data modules are covered:

- Digital Terminal Data Module (DTDM)
- Z702AL1-DSU Data Module Base
- Modular Trunk Data Module (MTDM)
- Modular Processor Data Module (MPDM)
- 7400A Data Module
- 7400B Data Module
- 7500B Data Module
- 3270 Data Module
- Z3A Asynchronous Data Unit (ADU)
- Pooled Modem

### **Digital Terminal Data Module (DTDM)**

The DTDM provides synchronous or asynchronous voice and data communications to 7403D and 7405D digital voice terminal users who have a terminal or personal computer. The DTDM and voice terminal integrate data and voice into the DCP for the switch.

### **Z702AL1-DSU Data Module Base**

The Z702AL1-DSU Data Module Base provides the DCE interface connection between a 7407D voice terminal and data terminals. The module provides full-duplex asynchronous operation only. The module and 7407D voice terminal integrate data and voice into the DCP for the switch.

### **Modular Trunk Data Module (MTDM)**

The MTDM provides an EIA-232C DTE interface for connection to off-premises (out-of-building) private-line trunk facilities or a switched telecommunications network, and a DCP interface for connection to the switch. The MTDM may also serve as part of a conversion resource for modem pooling. The MTDM is also used to interface with DCE-type multiplexers.

### **Modular Processor Data Module (MPDM)**

The MPDM provides a DCE asynchronous or synchronous interface for connection to data terminals, CDR output devices, Manager I or G3r-MT terminals, on-premises (in-building) administration terminals, and host computers.

The MPDM can be preset in the factory to provide the following interfaces: EIA-232C, RS-449, V.35, and RS-366 to support ACU (Automatic Calling Unit)-type dialing.

The MPDM can be configured to support the Data Call Setup or Off-Premises Data-Only Extension feature. The MPDM also supports data rates of 56 and 64 kbps for downloading and other high-speed data transfer requirements.

### **7400A Data Module**

The 7400A Data Module may be used instead of an MTDM when supporting the combined Modem Pooling feature. The 7400A Data Module supports asynchronous operation and provides a DCP interface to the switch and an EIA-232C interface to the associated modem.

### **7400B Data Module**

The 7400B Data Module supports asynchronous data communications and can operate in the stand-alone mode for data-only service or in the linked mode, which provides simultaneous voice and data service (acts like a DTDM). The 7400B provides voice and data communications to 7400D-series voice terminals and the 602A1 CallMaster voice terminal that have a connection to a data terminal or personal computer. The 7400B integrates data and voice into the DCP protocol required to interface to the switch via a port on a Digital Line circuit pack. The 7400B may be used instead of an MPDM when asynchronous operation at speeds of 19.2 kbps or less is required to provide a DCP interface to the switch for data terminals, printers, etc. The 7400B does not support synchronous operation and keyboard dialing.

### **7500B Data Module**

The 7500B Data Module supports synchronous or asynchronous communications and can operate in the stand-alone mode for data-only service or in linked mode, which provides simultaneous voice and data service. The 7500B provides voice and data service to 7500-series voice terminals and the 8503T voice terminal. The 7500B integrates data and voice into the ISDN protocol required to interface to the switch via a port on the BRI circuit pack. The 7500B may be used instead of an Asynchronous Data Module (ADM) when synchronous operations at speeds of up to 64 kbps are required.

### **3270 Data Module**

The 3270 Data Module provides a Category A coaxial DCE interface for connection to 3270-type data terminals or a cluster controller. It also provides a DCP interface connection to the digital switch.

The 3270 is available in the following three models:

- 3270T (Terminal)—Connects to a Category A 3270-type terminal, such as the 3278 Information Delivery System. The 3270T Data Module must connect through the digital switch to a 3270C (Controller) Data Module.
- 3270A (Asynchronous)—Provides the same function as the 3270T Data Module. It also allows the 3270-type terminal to emulate a Digital Equipment Corporation VT 100 or an AT&T asynchronous terminal.
- 3270C (Controller)—Connects an IBM® 3274 or 3276 cluster controller to the digital switch®. A 3270C Data Module can contain up to eight ports.

### **Z3A Asynchronous Data Unit (ADU)**

The Z3A ADU is a DCE-type device that allows direct connection between EIA-232C equipment and the TN726 Data Line circuit pack. The ADU can handle standard data rates from 300 to 19,200 bps, asynchronous, full duplex only.

The ADU is used when the DTE is located more than 50 feet from the Data Line circuit pack and is installed with the DTE. An optional originate or disconnect switch may be used with the ADU.

### **Pooled Modem**

Modem pools may reduce the number of modems and may also reduce the number of dial-up facilities needed for data transmissions. The integrated and external modem pools can handle up to 32 simultaneous data calls per group in up to 5 groups. Integrated modem pools can operate at speeds of 300, 1200, and 2400 bps. Combined modem pools (external modem pools) can operate at speeds up to 19.2 kbps.

### Data Communications Adjuncts

Adjunct equipment may be connected to the switch without any unique switched-based call processing, administration, or maintenance capabilities. In addition to the Z3A Message Waiting Indicator, DEFINITY Generic 1 and Generic 3 can support the following adjuncts:

- EIA terminal such as the 4410 BCT (TTY 5410) and 4415 (TTY 5420)
- Personal computers, such as the AT&T PC 6300, PC 7300, PC 6312, or 6386 Work-Group System (WGS)
- HORIZON® communications system, MERLIN® communications system, and Information Systems Network (local area network) switching systems
- Two multiplexers, the Channel Expansion Multiplexer (which doubles the channel capacity of a DS1 facility to 44 voice band channels) and the Channel Division Multiplexer (which provides non-switched private line connections over DS1 facilities)
- Protocol converters to allow ASCII terminals and personal computers to communicate with SNA/SDLC IBM computer and bisynchronous networks, thus protecting investments in existing low-cost terminals as data networks grow or are integrated and as protocols change
- CONVERSANT Voice Information System, AT&T's voice response unit offering

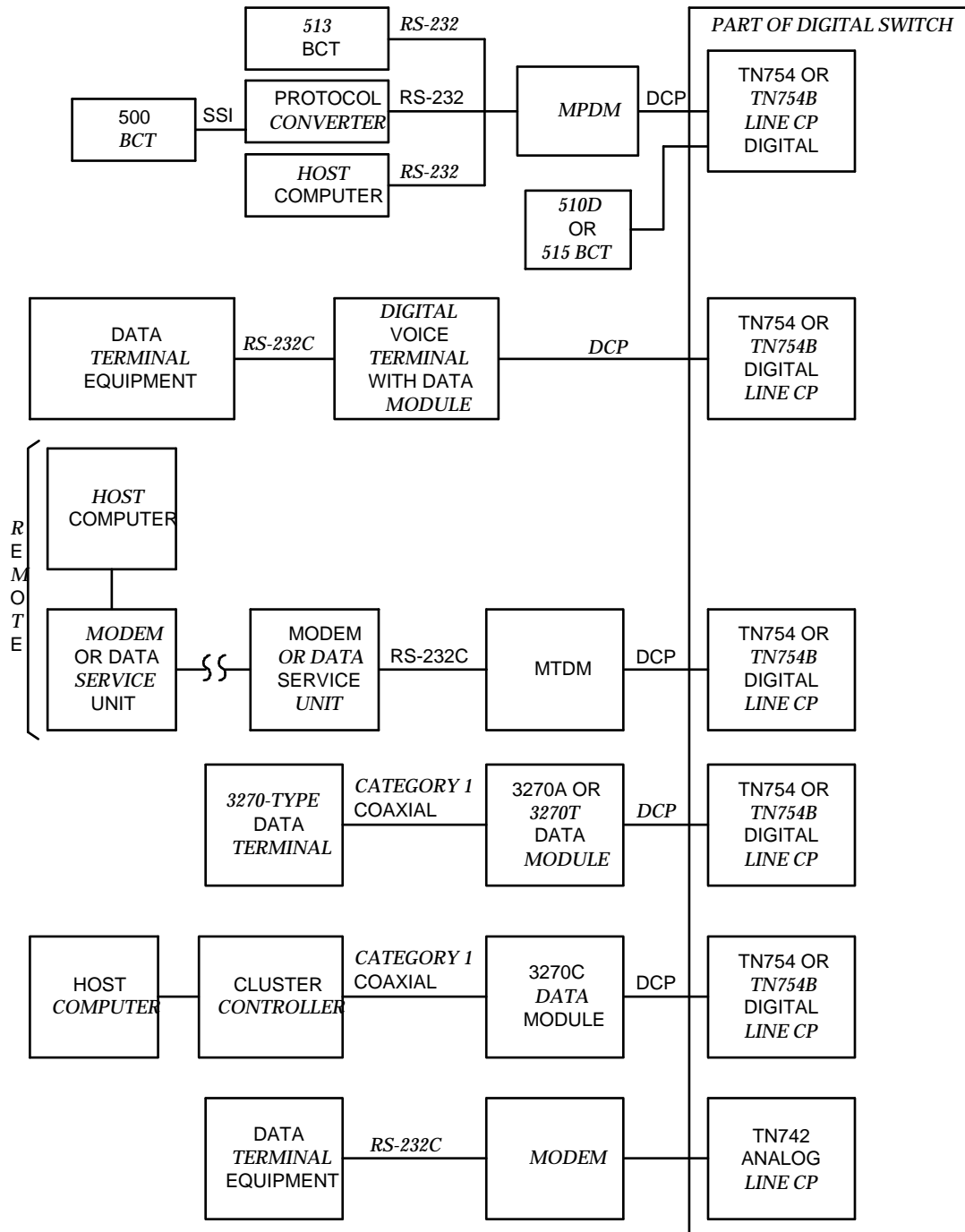

FIGURE 2. Data Endpoint (Terminal, Personal Computer, Host, and Customer-Provided Equipment) Connections



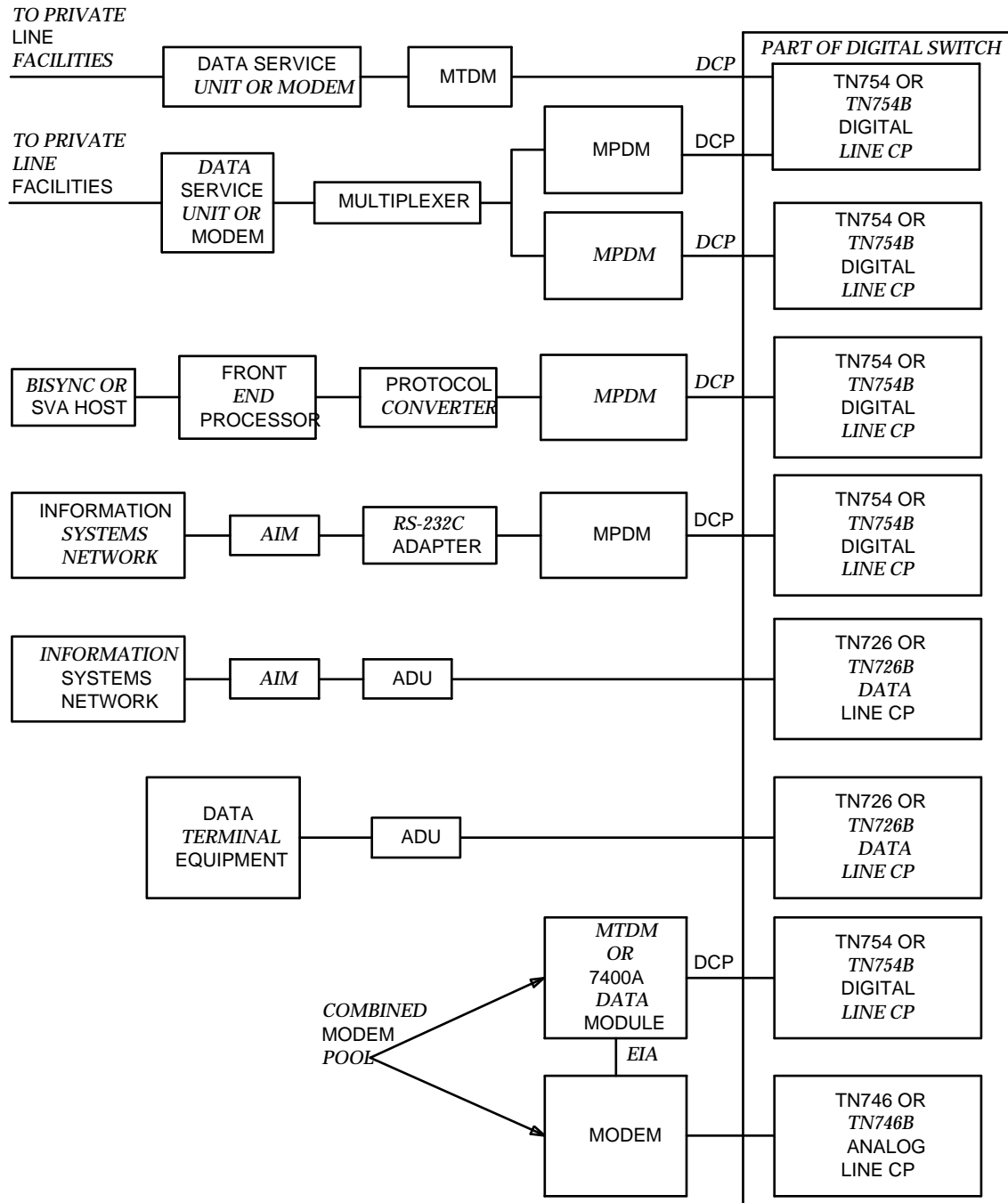

FIGURE 3. Data Endpoint (EIA-232C) Connections

## Display Terminals and Printers

The DEFINITY Communications System Generic 1 and Generic 3 is compatible with terminals and printers having EIA-232C or DCP interfaces.

System access for administration of DEFINITY Communications System Generic 1 and Generic 3 is performed by a Manager I terminal for G1 and G3i or G3r-MT for G3r, a Remote Administration terminal (that is, a Manager I or G3r-MT terminal that is more than 50 feet from the system cabinet and uses a dial-up capability), or by an AT&T location. System maintenance can be performed from the Manager I or G3r-MT terminal or from an AT&T location.

The Manager I or G3r-MT terminal can be a 715 Business Communications Terminal (BCT), 615 Multi-Tasking Terminal (MT) with a 513 BCT emulation cartridge, 513 BCT, 515 BCT, 610 BCT, 4410 terminal, or 4425 terminal located within 50 feet of the system cabinet. A remote Manager I or G3r-MT terminal requires the use of a modem to allow dial-up to the system.

### Remote Administration

Remote Administration allows the system to be administered from a remote terminal located on or off the customer's premises. A terminal located more than 50 feet from the system cabinet is considered remote and can use a modem to dial-up the system. If it is on-premises, a data module or an ADU can be used in place of a modem. The remote terminal performs the same functions as the local Manager I or G3r-MT terminal.

The 513 BCT, 515 BCT, 610 BCT, 615 MT, 715 BCT, 4410 terminal, or 4425 terminal may be used as the local (on-premises) Manager I or G3r-MT terminal or the remote terminal for DEFINITY Generic 1 and Generic 3 systems. The 510D terminal can be used as an on-premises remote terminal for all systems if it is connected directly to the switch or as an off-premises remote terminal behind a remote G1 or G3 if modem pooling is used on the G1 or G3 that is being dialed.

If the remote terminal is a 4410 terminal, 513 BCT, 610 BCT, 615 MT, or 715 BCT, it must be connected to the switch via a Processor Data Module (PDM), Digital Terminal Data Module (DTDM), or Data Line circuit pack port. If a 4425 terminal (with integrated modem) or 515 BCT is used as a remote terminal, a PDM or DTDM is not required, but a System Access Port is required for G3r.

Table J provides a listing of the system data terminals.

**TABLE J. System Data Terminals**

Terminal/ (Protocol)	Description	Application
510D (DCP)	See <i>DEFINITY® Communications System Generic 1 and System 75 and System 85—Terminals and Adjuncts—Reference</i> , 555-015-201.	<ul style="list-style-type: none"> <li>• Executive Voice/Data Terminal</li> <li>• Remote administration terminal</li> </ul>
610 BCT (EIA)	See <i>DEFINITY® Communications System Generic 1 and System 75 and System 85—Terminals and Adjuncts—Reference</i> , 555-015-201.	<ul style="list-style-type: none"> <li>• Local (within 50 feet of system cabinet) administration terminal</li> <li>• General purpose data terminal</li> </ul>
615 MT (EIA)	See <i>615 Multi-Task Terminal User's Guide</i> , 999-300-302.	<ul style="list-style-type: none"> <li>• Local or remote (Manager I or G3-MT) administration terminal</li> <li>• General purpose data terminal</li> </ul>
715 BCS (EIA)	See <i>715 BCS User's Guide</i> , 999-300-765.	<ul style="list-style-type: none"> <li>• Local or remote (Manager I or G3-MT) administration terminal</li> <li>• General purpose data terminal</li> </ul>
513 BCT (EIA)	See <i>DEFINITY® Communications System Generic 1 and System 75 and System 85—Terminals and Adjuncts—Reference</i> , 555-015-201.	<ul style="list-style-type: none"> <li>• Remote SAT (G1)</li> <li>• General purpose data terminal</li> </ul>
515 BCT (DCP/EIA)	See <i>DEFINITY® Communications System Generic 1 and System 75 and System 85—Terminals and Adjuncts—Reference</i> , 555-015-201.	<ul style="list-style-type: none"> <li>• Executive Voice/Data Terminal</li> <li>• Remote administration terminal</li> <li>• General purpose data terminal</li> </ul>
4410 Display Terminal (EIA)	See <i>DEFINITY® Communications System Generic 1 and System 75 and System 85—Terminals and Adjuncts—Reference</i> , 555-015-201.	<ul style="list-style-type: none"> <li>• Local or remote administration terminal</li> <li>• General purpose data terminal</li> </ul>
4425 Display Terminal (EIA)	See <i>DEFINITY® Communications System Generic 1 and System 75 and System 85—Terminals and Adjuncts—Reference</i> , 555-015-201.	<ul style="list-style-type: none"> <li>• Local or remote administration terminal</li> <li>• General purpose data terminal</li> </ul>

Table K provides a listing of the system printers and their typical applications.

**TABLE K. System Printers**

Printer	Description	Application
443	<ul style="list-style-type: none"> <li>● 132 Columns</li> <li>● Matrix printer</li> <li>● Tractor feed</li> <li>● 30 characters per second (cps)</li> <li>● Draft quality output</li> <li>● SSI Interface</li> </ul>	Provides hard copy of data received under the direction of a data communications processor or controller.
445	<ul style="list-style-type: none"> <li>● 132 Columns</li> <li>● Line printer with tractor feed</li> <li>● 55 cps</li> <li>● Draft quality output</li> <li>● 3 Interface options:                             <ul style="list-style-type: none"> <li>– EIA</li> <li>– IBM computer</li> <li>– Centronics®</li> </ul> </li> <li>● 96 Upper/Lower Case Characters</li> </ul>	Printing messages received on-line from a Message Server or controller.
450	<ul style="list-style-type: none"> <li>● 10, 12, 15 char. per inch (variable)</li> <li>● Vertical line spacing 3/6/8 lines per inch (variable)</li> <li>● Full font printer</li> <li>● Document quality output</li> <li>● 5000 feet maximum distance from host</li> <li>● SSI Interface</li> <li>● 45 cps</li> </ul>	Auxiliary printer where document quality is the primary consideration. A slave device (auxiliary only) to an applications processor via an SSI data link.
460 and 572	<ul style="list-style-type: none"> <li>● Medium speed</li> <li>● Bidirectional</li> <li>● Draft quality</li> <li>● Matrix printer</li> <li>● Interface options:                             <ul style="list-style-type: none"> <li>– EIA</li> <li>– SSI</li> <li>– IBM computer</li> </ul> </li> <li>● Up to 240 cps</li> <li>● 5000 feet maximum distance from host</li> </ul>	Prints data received under direction of a communications processor or controller when copy quality is essential.

(continued on next page)

**TABLE K (continued).**  
**System Printers**

Printer	Description	Application
470	<ul style="list-style-type: none"> <li>● Desktop Dot Matrix</li> <li>● Draft quality</li> <li>● 120 cps or 10 cps</li> <li>● Interface Options:                             <ul style="list-style-type: none"> <li>– IBM computer</li> <li>– Centronics</li> </ul> </li> </ul>	Prints data received under direction of a communications processor or controller.
475 and 573	<ul style="list-style-type: none"> <li>● Letter quality matrix printer</li> <li>● 120 cps or 10 cps</li> <li>● Bidirectional</li> <li>● EIA Interface</li> <li>● 50 feet maximum distance from host</li> </ul>	Interface to a printer system. Prints under the direction of a communications processor or controller. May be used as the System Printer in support of the Report Scheduler feature.

## Distributed Communications System (DCS)

Distributed Communications System (DCS) allows two or more switches to provide transparency for certain attendant and voice terminal features as if the cluster were a single large switch. DCS simplifies dialing procedures between locations and allows the use of some of the system's features between locations. To clarify this further, if you have two switches in the same company that are networked together but do not have DCS, if a call from one display terminal is made to another display terminal, the terminal receiving the call displays only the trunk line over which the call was placed. If the switches have DCS, however, the extension from which the call is made appears. Another example is that the Leave Word Calling button can be used where two switches have DCS. Figure 4 shows how the DCS can be connected to the system.

For detailed information on how to add DCS to a system, see *DEFINITY® Communications System Generic 1 and Generic 3i—Upgrades and Additions*, 555-204-106 or *DEFINITY® Communications System Generic 3r—Upgrades and Additions*, 555-230-106.

REMOTE SYSTEM KANSAS POWER CO. DETAIL OF THE POWER SYSTEM OF THE STATE OF KANSAS, 1922

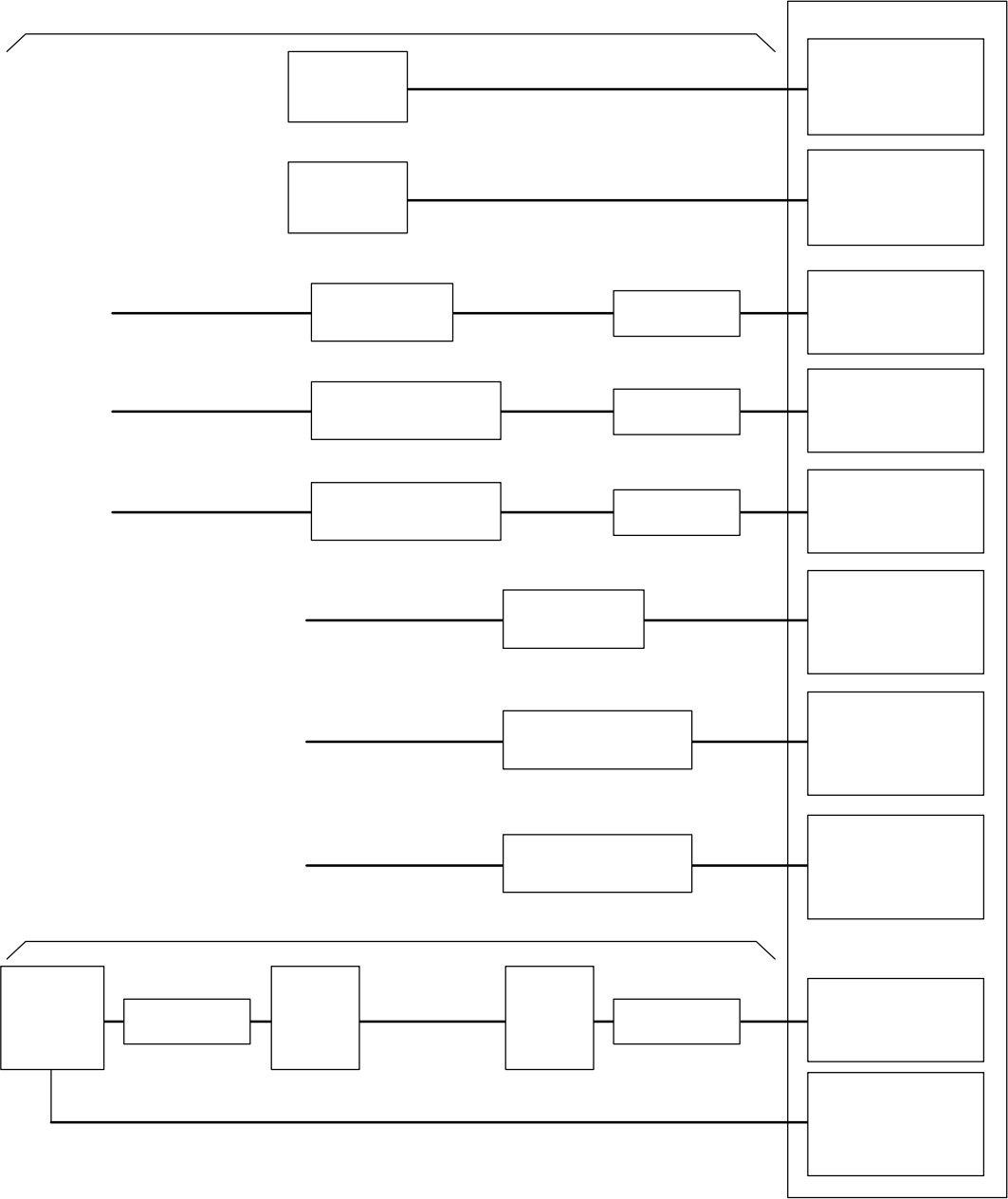

FIGURE 4. G1 and G3i DCS Used in a Long Haul and Short Haul Connection

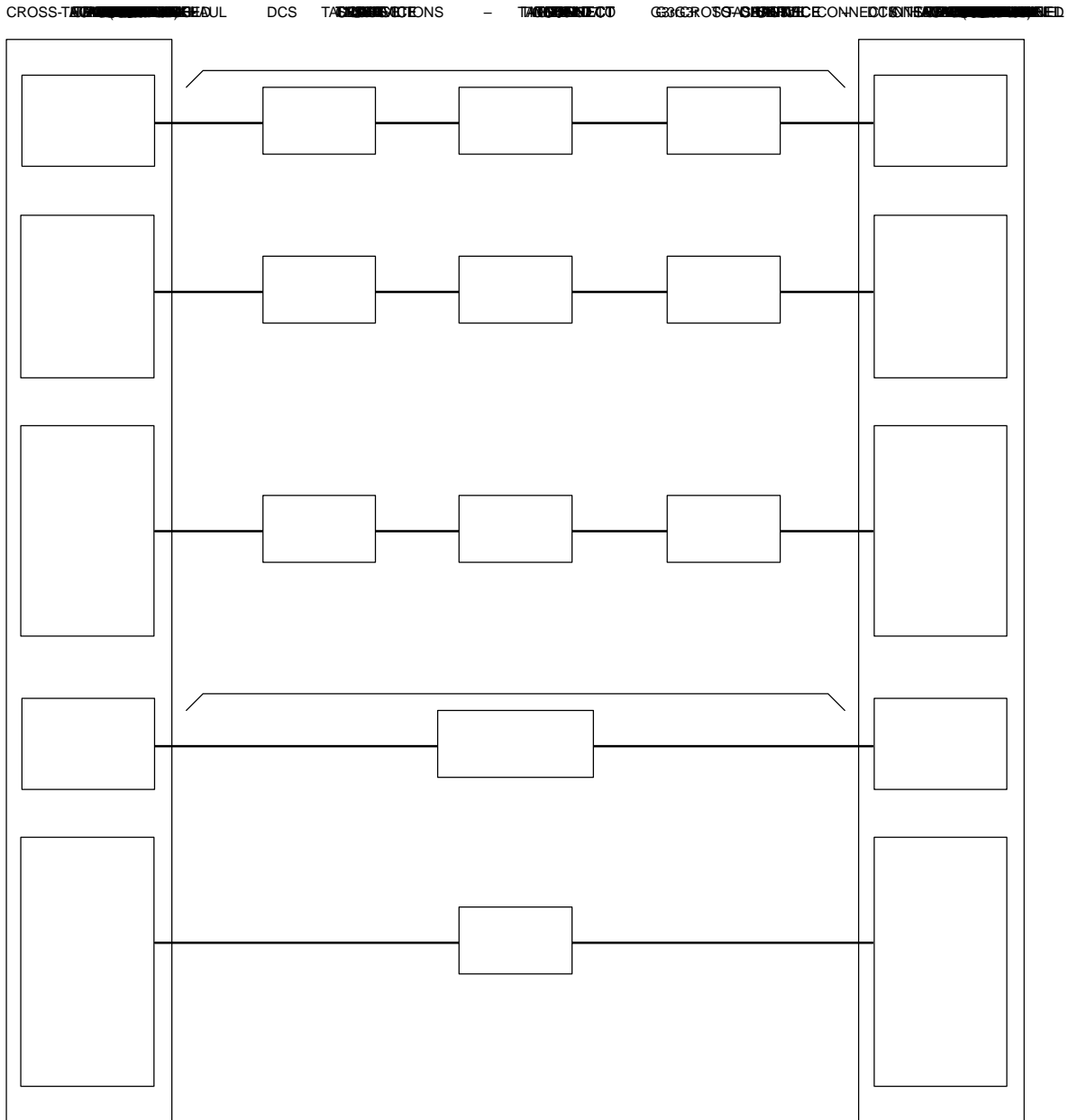

FIGURE 5. G3r to G3r DCS Used in a Long Haul and Short Haul Connection



CROSS-CONNECTED DS1 CONNECTIONS CROSS-CONNECTED G1/G3DCS CONNECTIONS

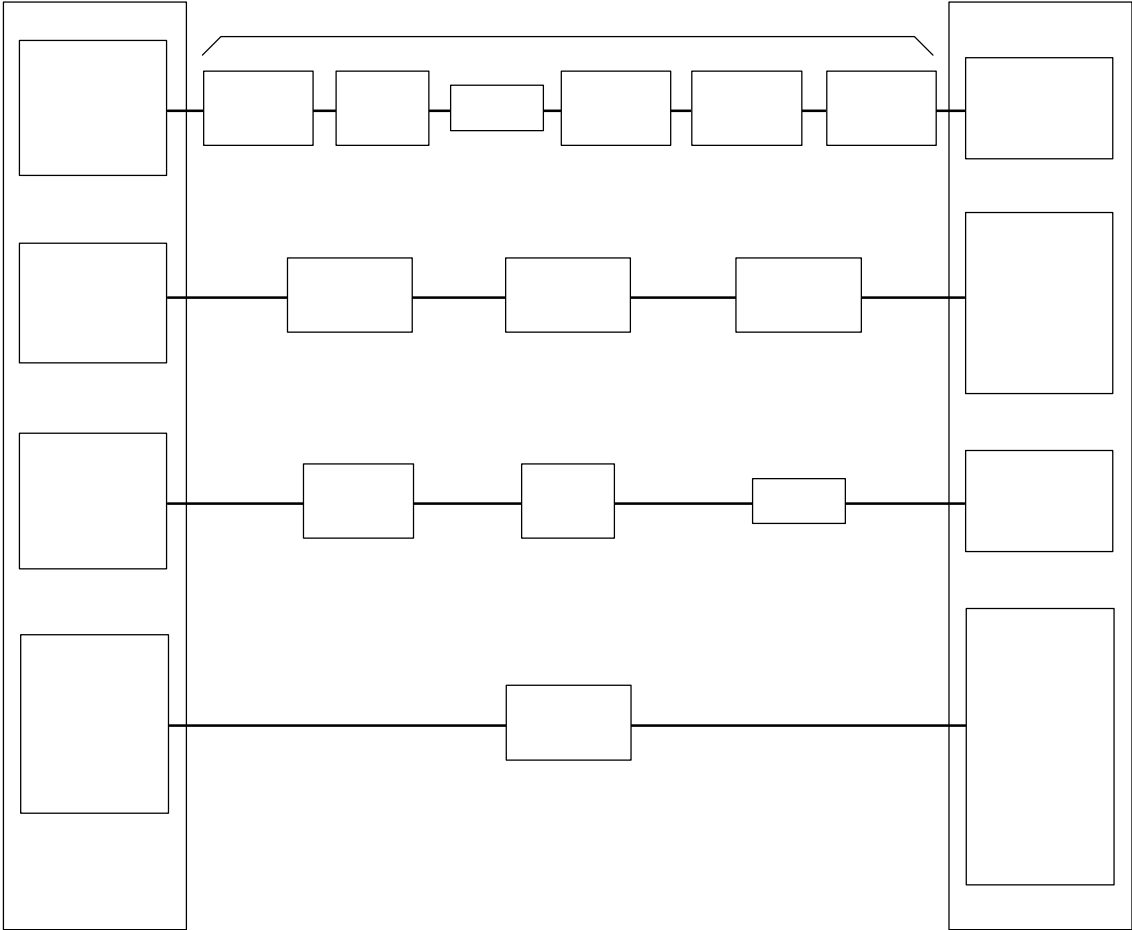
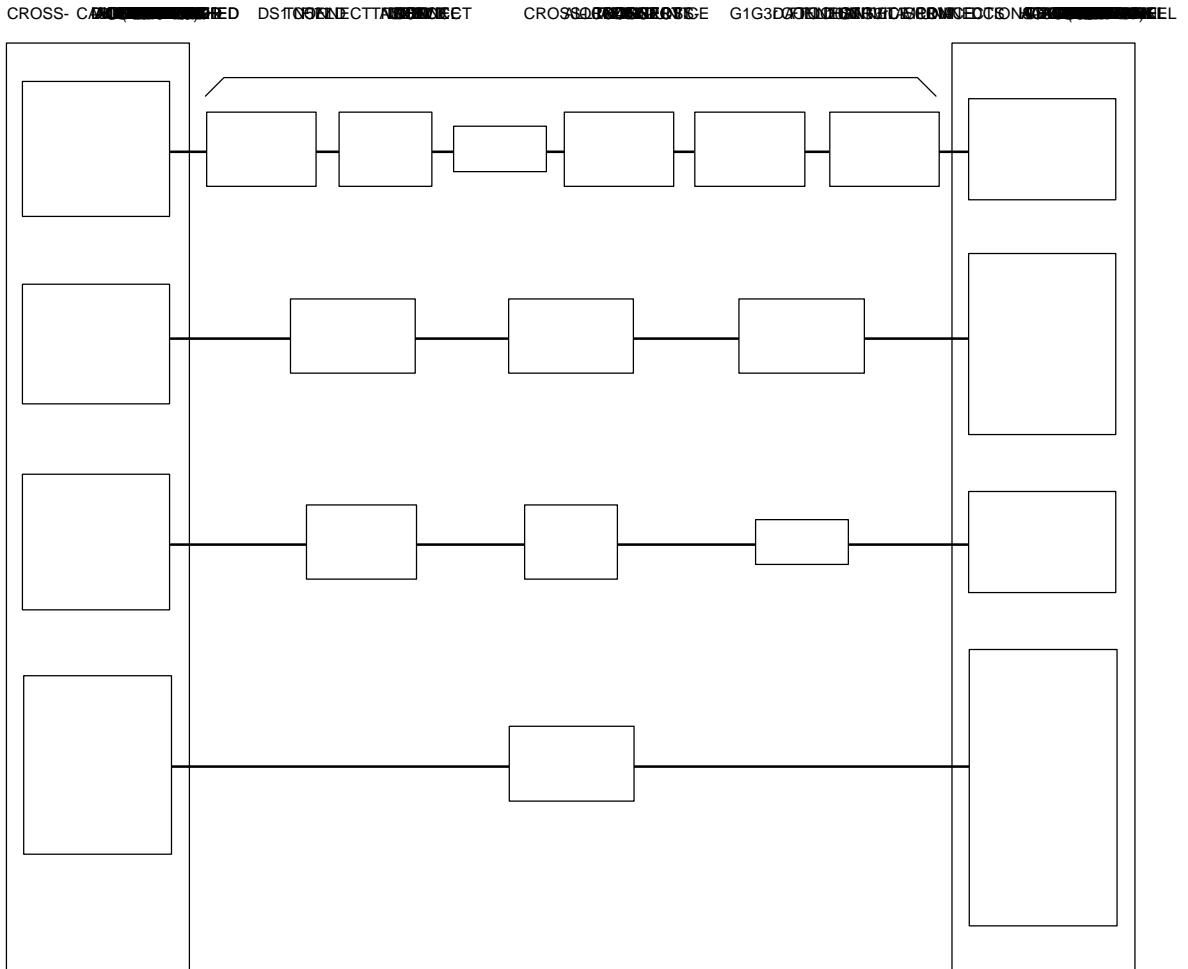
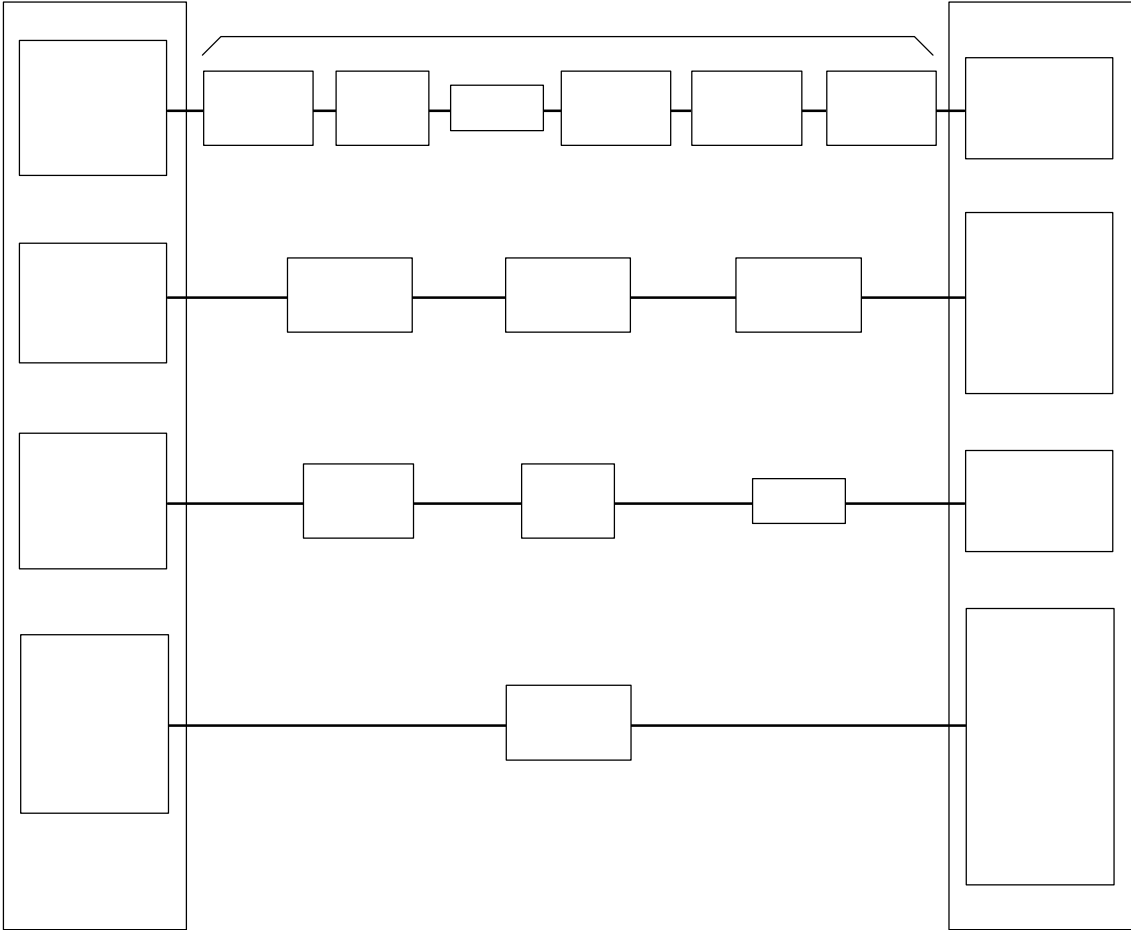

FIGURE 6. G3r to G1 DCS Used in a Short Haul Connection

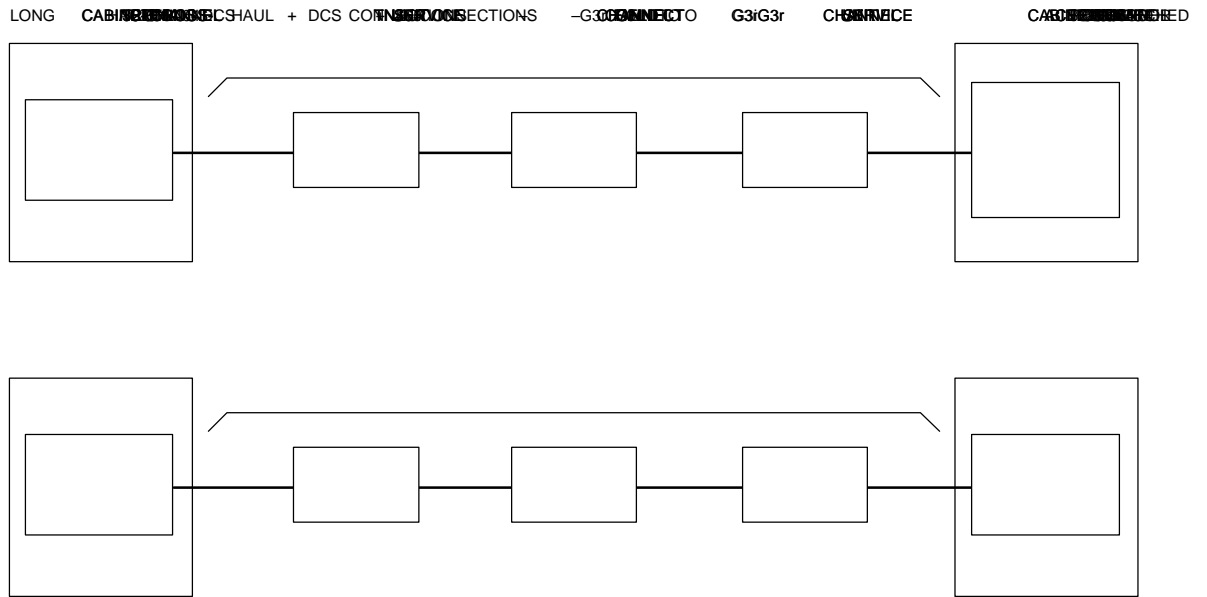

**FIGURE 7. G3r to G2 Traditonal Module DCS Used in a Short Haul and Long Haul Connection**

CROSS-CONNECTED DS1 CONNECTIONS BETWEEN CROSS-CONNECTS G1/G3 TO G2/2 UNIVERSAL MODULES



**FIGURE 8. G3r to G2 Universal Module DCS Used in a Short Haul and Long Haul Connection**



**FIGURE 9. G3r to G3i and G3r to G3r DCS Plus  
Used in a Long Haul Connection**

### Traffic Considerations

To determine if traffic engineering calculations should be made for G1 or G3i, consider the following (for G3r, traffic engineering will be done regardless):

	YES	NO
1 - Will the number of busy-hour calls meet or exceed 7200 (G1) or 10,000 (G3i)?	<input type="checkbox"/>	<input type="checkbox"/>
2 - Will the call activity be different than the balance of 36% outgoing, 36% incoming, 28% intra-premises ( $\pm 10\%$ )?	<input type="checkbox"/>	<input type="checkbox"/>
3 - Will the trunk (all types) to terminal ratio exceed 50%?	<input type="checkbox"/>	<input type="checkbox"/>
4 - Is ARS requested with more than 425 terminals?	<input type="checkbox"/>	<input type="checkbox"/>
5 - Is DID with Message Center Service requested and are there more than 425 terminals?	<input type="checkbox"/>	<input type="checkbox"/>
6 - Will more than 50% of the incoming traffic be handled by the Attendant?	<input type="checkbox"/>	<input type="checkbox"/>
7 - Will AUDIX be used?	<input type="checkbox"/>	<input type="checkbox"/>
8 - Will DCS or ISDN-PRI be used?	<input type="checkbox"/>	<input type="checkbox"/>

In most domestic locations, the DOSS/ATTOMS-CPS configurator must be used for all DEFINITY G1 and G3 designs. Note carefully any configurator report messages associated with the above items that are answered "yes."

## Network Access Facilities

For each type of facility listed on Table L, enter the quantity in the appropriate block. The Ground Start column is for record and order preparation purposes only.

**TABLE L. Network Access Facilities**

Facility	Quantity			If Ground Start	Total
	1-Way In	1-Way Out	2-Way		
1. LOCAL CENTRAL OFFICE					
a. CO Trunks					
b. Personal CO Lines					
c. Subtotal					
2. FOREIGN CENTRAL (FX) OFFICE					
a. CO Trunks					
b. Personal Lines					
c. Subtotal					
3. 800 SERVICE					
a. Band 1					
b. Band 2					
c. Band 3					
d. Band 4					
e. Band 5					
f. Subtotal					
4. WATS					
a. Number of WATS lines					
b. Personal Lines (included in a)					
g. Subtotal					

(continued on the next page)

**TABLE L (continued).**  
**Network Access Facilities**

Facility	Quantity			If Ground Start	Total
	1-Way In	1-Way Out	2-Way		
5. DIRECT INWARD DIAL (DID) LINES					
a. DID Lines					
b. Subtotal					
6. TIE LINES (include DCS)					
a. Tie Lines (exclude b)					
b. Release Link Trunks					
c. Subtotal					
7. DS1 FACILITIES (TN722 or TN767 circuit pack or 464)					
a. Voice					
b. Alternate Voice/Data					
c. ISDN PRI (TN767 or 464 circuit pack)					
e. Subtotal					
8. PRIVATE LINES					
a.					
b.					
c.					
d. Subtotal					

## Circuit Pack Determination

Terminals, trunks, auxiliary equipment, and customer-provided equipment (CPE) require an interface (circuit pack) to be connected to the system.

**Note:** All circuit packs are referred to by their circuit pack numbers only. Version letters (for example, the “B” in TN750B, the “C” in TN464C) are not included. Assume the latest version is to be used for all circuit packs.

Any customer-provided equipment that is not FCC-registered requires a 36A Coupler (for music) or 278A adapter (for paging) and a 2012D Transformer. This enables a customer to connect an external music or paging system to the switch where the interface may not match exactly.

Determine the types and quantities of circuit packs on the following worksheets, and enter the totals in Table M. Information required in these worksheets may be obtained from the tables previously filled out in this manual. For a detailed description of the system’s circuit packs, see *DEFINITY® Communications System Generic 3—System Description, 555-230-200*.

For a G3i, two memory circuit packs are required for simplex systems and four for duplex systems (PEC 63526). For a G3r, the quantity is predetermined at two memory circuit packs, so no planning is required.

For G3i CallVisor ASAI, one packet control circuit pack (PEC 63533) and one ISDN-BRI circuit pack (PEC 65512) are required for a simplex system. If duplicated with CallVisor ASAI, two packet control circuit packs plus one TN771 Maintenance circuit pack (PEC 65524) per port network are required.

For G3r CallVisor ASAI, the packet control circuit pack(s) and, for duplicated systems, maintenance circuit pack are already included in the configuration, so the only circuit pack required from planning is one ISDN-BRI circuit pack (PEC 65512).

In G1 and G3i configurations, port networks are connected directly to each other. In G3r, where there are four or more port networks, they are connected to the TN573 Switch Node Interface circuit pack, with one TN573 for each port network. The TN573 circuit packs are located in a switch node carrier, usually the PPN, E Carrier. This configuration, called the Center Stage Switch (CSS), reduces the amount of connections needed between port networks. You can have a CSS for fewer than four port networks, but it is not recommended unless you anticipate expanding to four or more port networks.

Each G3r cabinet, including the PPN that contains the CSS, requires an Expansion Interface TN570. Only the CSS in the PPN contains a Switch Node Interface TN573 and Switch Node Clock TN572. If one of the cabinets is remoted, both ends of the connection require a DS1 Converter TN574. The TN776 Expansion Interface circuit pack cannot be used for the G3r CSS.

Note also that the TN776 Expansion Interface circuit pack is required with ISDN-BRI in the G3i, but cannot be used at all in the G3r. The Expansion Interface circuit pack for the G3r is the TN570.



**DISK DRIVE (TN1657) (G3r Only)**

Enter the number of:

(A) Center Stage Switches (CSSs)

One disk drive only is needed for a simplex G3r system with a CSS. Two are required for duplicated systems. Optionally, the disk drive may also be added to increase booting speed.

PEC  
\_\_\_\_\_ 63324

**PACKET DATA LINE (TN553) (G3r Only)**

Every time you have a TN553, you'll need at least 1 TN726 port.

Enter the number of:

- (A) CDR Ports
- (B) Serial printer
- (C) Manager 1 switch connected (instead of EIA-232 connected)
- (D) Property Management System
- (E) TN750 Announcement circuit pack
- (F) BCMS Terminal
- (G) G3r-MA Terminal

TOTAL PORTS \_\_\_\_\_ ÷ 12 = \_\_\_\_\_ PEC  
63318

**ISDN-BRI LINE (TN556)**

Enter the number of:

- (A) 7505 ISDN-BRI voice terminals
- (B) 7506 ISDN-BRI voice terminals
- (C) 7507 ISDN-BRI voice terminals
- (D) 8503T ISDN-BRI voice terminals
- (E) CallVisor ASAI adjuncts

TOTAL PORTS \_\_\_\_\_ ÷ 12 = \_\_\_\_\_ PEC  
65512

**Note:** Using a passive bus arrangement, you can have up to 24 voice terminals per circuit pack. However, the terminals would have to be voice only.

**PACKET GATEWAY (TN577) (G3r Only)**

Enter the number of:

- (A) AUDIX Data Links
- (B) 3B Applications (CMS, MSA, CallVisor ISDN Gateway)
- (C) DCSs Between Switches

TOTAL PORTS \_\_\_\_\_ ÷ 4 = \_\_\_\_\_ PEC  
63317

**ANALOG LINE (TN742)**

If you are reusing a TN742 from an earlier system, enter the number of:

- (A) 7100 Series Sets..... \_\_\_\_\_
- (B) 2500/2554-Type Sets (On Premises)..... \_\_\_\_\_
- (C) 2500/2554-Type Off-Premises Extensions..... \_\_\_\_\_
- (D) 2500-Type Sets with Message Waiting  
Indicator/Recall capability..... \_\_\_\_\_
- (E) Rotary Dial Telephones (500-Type) ..... \_\_\_\_\_
- (F) 510As..... \_\_\_\_\_
- (G) Recorded Announcement Lines ..... \_\_\_\_\_
- (H) Teleconferencing Lines  
(QUORUM® teleconferencing equipment or CPE) ..... \_\_\_\_\_
- (I) Lines Equipped With Modems Only ..... \_\_\_\_\_
- (J) External Pooled Modems ..... \_\_\_\_\_
- (K) Queue Warning Lamps (for UCD/DDC) ..... \_\_\_\_\_
- (L) Loudspeaker Paging Access Lines ..... \_\_\_\_\_
- (M) Code Calling Access Lines ..... \_\_\_\_\_
- (N) Radio Paging Access Lines (Requiring Tip and Ring only)..... \_\_\_\_\_
- (O) Recorded Telephone Dictation Lines  
(Requiring Tip and Ring only)..... \_\_\_\_\_
- (P) Analog Lines for other CPE ..... \_\_\_\_\_
- (Q) Line for TAAS External Alert ..... \_\_\_\_\_
- (R) Future Growth ..... \_\_\_\_\_

TOTAL PORTS \_\_\_\_\_ ÷ 8 = \_\_\_\_\_ PEC  
63111

Additional information on analog line characteristics is in the following table.

Feature	Analog Line Circuit Packs				
	TN742	TN769	TN746	TN746B	TN479
Number of Ports	8	8	16	16	16
Neon Message Waiting Indicators	No	Yes	Yes	Yes	Yes
LED Terminals	Yes	Yes	Yes	Yes	Yes
Feed Voltage	-48 V	-48 V	-24 V	-48 V	-24V
Hard Bridging	Yes	Yes	No	Yes	No
Station Adjunct	Yes	Yes	No	Yes	No
Secondary Lightning Protection	Yes	Yes	No	Yes	No
Same Premises—Out-of-Building	Yes	Yes	No	Yes	No
Terminals	500-Type 2500-Type 7100 Series	500-Type 2500-Type 7100 Series	500-Type 2500-Type 7102A*	500-Type 2500-Type 7100 Series	500-Type 2500-Type 7100 Series
Range With 500-Type/ 2500-Type/7102A Terminal† (24-Gauge Wire)	20,000 Feet	20,000 Feet	3,100 Feet	20,000 Feet	3,000 Feet
Range With 7101A/7103A Terminals (24-Gauge Wire)	15,200 Feet	15,200 Feet	Not Supported	15,200 Feet	Not Supported
Ringer Loads	3	3	3	3	3
Simultaneous Ports Ringing Ringing	4	4	4	8 †	4

\* The TN746 circuit pack supports the 7102A terminal, but does not support the 7101A or 7103A terminals.

† The TN746B circuit pack allows ringing on four ports of each half of the circuit pack (for a maximum of eight simultaneous ports ringing). A user attempting to ring one half of the circuit pack when all four ports are busy receives the busy tone.

**CALL CLASSIFIER (TN744)**

Eight touch-tone receiver ports are provided on each TN744 Call Classifier circuit pack. The TN744 circuit pack is used exclusively for receiving touch-tone input for the Call Prompting feature, classifying outgoing calls for the Answer Detection feature, and classifying outgoing calls for an outgoing call management system. Each of these are optional features that must be properly engineered. A maximum of 10 TN744 may be used in a G3i or G3r system (TN744 is not supported in G1).

Enter the number of:

- (A) Touch-tone receivers for Call Prompting ..... \_\_\_\_\_
- (B) Touch-tone receivers for Answer Detection ..... \_\_\_\_\_
- (C) Touch-tone receivers for outbound call management ..... \_\_\_\_\_

TOTAL PORTS \_\_\_\_\_ ÷ 8 = \_\_\_\_\_ PEC 63532

**ANALOG LINE (TN746)**

Enter the number of:

- (A) 7100 Series Sets ..... \_\_\_\_\_
- (B) 2500/2554-Type Sets (On Premises)..... \_\_\_\_\_
- (C) 2500/2554-Type Off-Premises Extensions..... \_\_\_\_\_
- (D) 2500-Type Sets with Message Waiting  
Indicator/Recall capability..... \_\_\_\_\_
- (E) Rotary Dial Telephones (500-Type) ..... \_\_\_\_\_
- (F) 510As..... \_\_\_\_\_
- (G) Recorded Announcement Lines ..... \_\_\_\_\_
- (H) Teleconferencing Lines  
(QUORUM® teleconferencing equipment or CPE) ..... \_\_\_\_\_
- (I) Lines Equipped With Modems Only ..... \_\_\_\_\_
- (J) External Pooled Modems ..... \_\_\_\_\_
- (K) Queue Warning Lamps (for UCD/DDC) ..... \_\_\_\_\_
- (L) Loudspeaker Paging Access Lines ..... \_\_\_\_\_
- (M) Code Calling Access Lines ..... \_\_\_\_\_
- (N) Radio Paging Access Lines (Requiring Tip and Ring only)..... \_\_\_\_\_
- (O) Recorded Telephone Dictation Lines  
(Requiring Tip and Ring only)..... \_\_\_\_\_
- (P) Analog Lines for other CPE ..... \_\_\_\_\_
- (Q) Line for TAAS External Alert ..... \_\_\_\_\_
- (R) Future Growth ..... \_\_\_\_\_

TOTAL PORTS \_\_\_\_\_ ÷ 16 = \_\_\_\_\_ **PEC**  
63136

For additional information on analog line circuit pack characteristics, see “Analog Line (TN742).”

**ANALOG LINE (TN479 - For International DEFINITY G1 Only)**

Enter the number of:

- (A) 7100 Series Sets ..... \_\_\_\_\_
- (B) 2500/2554-Type Sets (On Premises)..... \_\_\_\_\_
- (C) 2500/2554-Type Off-Premises Extensions..... \_\_\_\_\_
- (D) 2500-Type Sets with Message Waiting  
Indicator/Recall capability..... \_\_\_\_\_
- (E) Rotary Dial Telephones (500-Type) ..... \_\_\_\_\_
- (F) 510As..... \_\_\_\_\_
- (G) Recorded Announcement Lines ..... \_\_\_\_\_
- (H) Teleconferencing Lines  
(QUORUM® teleconferencing equipment or CPE) ..... \_\_\_\_\_
- (I) Lines Equipped With Modems Only ..... \_\_\_\_\_
- (J) External Pooled Modems ..... \_\_\_\_\_
- (K) Queue Warning Lamps (for UCD/DDC) ..... \_\_\_\_\_
- (L) Loudspeaker Paging Access Lines ..... \_\_\_\_\_
- (M) Code Calling Access Lines ..... \_\_\_\_\_
- (N) Radio Paging Access Lines (Requiring Tip and Ring only)..... \_\_\_\_\_
- (O) Recorded Telephone Dictation Lines  
(Requiring Tip and Ring only)..... \_\_\_\_\_
- (P) Analog Lines for other CPE ..... \_\_\_\_\_
- (Q) Line for TAAS External Alert ..... \_\_\_\_\_
- (R) Future Growth ..... \_\_\_\_\_

TOTAL PORTS \_\_\_\_\_ ÷ 16 = \_\_\_\_\_ 63803I  
PEC

For additional information on analog line circuit pack characteristics, see “Analog Line (TN742).”



**ANALOG LINE (TN769)**

This circuit pack is used for voice terminals with neon message waiting lamps.

If you are reusing a TN769 from an earlier system, enter the number of:

- (A) 7100 Series Sets..... \_\_\_\_\_
- (B) 2500/2554-Type Sets (On Premises)..... \_\_\_\_\_
- (C) 2500-Type Sets with Message Waiting  
Indicator/Recall capability..... \_\_\_\_\_
- (D) Rotary Dial Telephones (500-Type)..... \_\_\_\_\_
- (E) 510As ..... \_\_\_\_\_
- (F) Recorded Announcement Lines (Max 10) ..... \_\_\_\_\_
- (G) Teleconferencing Lines (Max 28)  
(QUORUM® teleconferencing equipment or CPE) ..... \_\_\_\_\_
- (H) Lines Equipped With Modems Only ..... \_\_\_\_\_
- (I) External Pooled Modems ..... \_\_\_\_\_
- (J) Queue Warning Lamps (for UCD/DDC)..... \_\_\_\_\_
- (K) Loudspeaker Paging Access Lines ..... \_\_\_\_\_
- (L) Code Calling Access Lines ..... \_\_\_\_\_
- (M) Radio Paging Access Lines (Requiring Tip and Ring only) ..... \_\_\_\_\_
- (N) Recorded Telephone Dictation Lines  
(Requiring Tip and Ring only)..... \_\_\_\_\_
- (O) Analog Lines for other CPE ..... \_\_\_\_\_
- (P) Line for TAAS External Alert..... \_\_\_\_\_
- (Q) Future Growth..... \_\_\_\_\_

TOTAL PORTS \_\_\_\_\_ ÷ 8 = \_\_\_\_\_ **PEC**  
63142

For additional information on analog line circuit pack characteristics, see “Analog Line (TN742).”

**AUXILIARY TRUNK (TN763)**

Enter the number of:

- (A) Trunks for Code Calling (Max 10) ..... \_\_\_\_\_
- (B) Trunks for Loudspeaker Paging Access (Max 10) (See Note) ..... \_\_\_\_\_
- (C) Trunks for Recorded Telephone Dictation..... \_\_\_\_\_
- (D) Music-on-Hold (Max 1) ..... \_\_\_\_\_
- (E) Trunks for other CPE (Audichron)..... \_\_\_\_\_
- (F) Future Growth ..... \_\_\_\_\_
- (G) (G3r Only) Malicious Call Trace..... \_\_\_\_\_
- (H) (G3r Only) Recorded Announcements..... \_\_\_\_\_

TOTAL PORTS \_\_\_\_\_ ÷ 4 = \_\_\_\_\_ PEC  
63118

**Note:** A 278A adapter and power supply is required for each paging zone, unless PagePac paging system equipment is used.

**CENTRAL OFFICE TRUNK (TN747)**

Enter the number of lines that will terminate as either trunk lines or as personal lines:

- (A) CO Lines ..... \_\_\_\_\_
- (B) WATS Lines ..... \_\_\_\_\_
- (C) 800 Service Lines ..... \_\_\_\_\_
- (D) FX Lines ..... \_\_\_\_\_
- (E) Future Growth ..... \_\_\_\_\_

TOTAL PORTS \_\_\_\_\_ ÷ 8 = \_\_\_\_\_ PEC  
63115

**CENTRAL OFFICE LOOP START TRUNK (TN465 - For International DEFINITY Only)**

Enter the number of lines that will terminate as either trunk lines or as personal lines:

- (A) CO Lines ..... \_\_\_\_\_
- (B) WATS Lines ..... \_\_\_\_\_
- (C) 800 Service Lines ..... \_\_\_\_\_
- (D) FX Lines ..... \_\_\_\_\_
- (E) Future Growth ..... \_\_\_\_\_

TOTAL PORTS \_\_\_\_\_ ÷ 8 = \_\_\_\_\_ PEC  
638011

**DATA LINE (TN726)**

Enter the number of:

- (A) EIA-232C Terminals/ADUs ..... \_\_\_\_\_
- (B) EIA-232C Host Computer Ports/ADUs ..... \_\_\_\_\_
- (C) (G3r Only) System Access Ports ..... \_\_\_\_\_

TOTAL PORTS \_\_\_\_\_ ÷ 8 = \_\_\_\_\_ PEC  
63130

**DIGITAL LINE (TN754B)**

Enter the number of:

- (A) 7401D Terminals..... \_\_\_\_\_
- (B) 7403D Terminals..... \_\_\_\_\_
- (C) 7404D Terminals..... \_\_\_\_\_
- (D) 7405D Terminals..... \_\_\_\_\_
- (E) 7406D Terminals..... \_\_\_\_\_
- (F) 7407D Terminals..... \_\_\_\_\_
- (G) 7410D Terminals..... \_\_\_\_\_
- (H) 7434D Terminals..... \_\_\_\_\_
- (I) 7444 Terminals..... \_\_\_\_\_
- (j) 7400A & BaData Modules..... \_\_\_\_\_
- (I) CallMaster® (602A1)..... \_\_\_\_\_
- (J) PDM/MPDM..... \_\_\_\_\_
- (K) TDM/MTDM..... \_\_\_\_\_
- (L) Attendant Consoles (Max 7, 6 Day + 1 Night)..... \_\_\_\_\_
- (M) Personal Terminal 510D..... \_\_\_\_\_
- (N) 515 BCT..... \_\_\_\_\_
- (O) External Pooled Modems..... \_\_\_\_\_
- (P) Future Growth..... \_\_\_\_\_

TOTAL PORTS \_\_\_\_\_ ÷ 8 = \_\_\_\_\_ PEC  
63114

**DIRECT INWARD DIALING TRUNK (TN753)**

Enter the number of:

- (A) DID Trunks..... \_\_\_\_\_
- (B) Future Growth ..... \_\_\_\_\_

TOTAL PORTS \_\_\_\_\_ ÷ 8 = \_\_\_\_\_ PEC  
63116

**DIRECT INWARD AND OUTWARD DIALING (DIOD) TRUNK  
(TN429 - For International DEFINITY G1 Only)**

Enter the number of:

- (A) DIOD Trunks ..... \_\_\_\_\_
- (B) Future Growth ..... \_\_\_\_\_

TOTAL PORTS \_\_\_\_\_ ÷ 8 = \_\_\_\_\_ PEC  
638021

**DS1 TIE TRUNK (TN722)**

If you are reusing a TN722 circuit pack from an earlier system, enter the number of:

- (A) Voice Grade Data Tie Trunks \* ..... \_\_\_\_\_
- (B) Alternate Voice/Data Tie Trunks \* ..... \_\_\_\_\_
- (C) DMI Tie Trunks \* ..... \_\_\_\_\_
- (D) Release Link Trunks ..... \_\_\_\_\_
- (E) Future Growth ..... \_\_\_\_\_

PEC  
 TOTAL PORTS \_\_\_\_\_ ÷ 23/24\* = \_\_\_\_\_ 63122

**DS1 TIE TRUNK (TN767 - For G1 only)**

Enter the number of:

- (A) Voice Grade Data Tie Trunks † ..... \_\_\_\_\_
- (B) Alternate Voice/Data Tie Trunks † ..... \_\_\_\_\_
- (C) DMI Tie Trunks † ..... \_\_\_\_\_
- (D) ISDN PRI Trunks † ..... \_\_\_\_\_
- (E) DID Trunks ..... \_\_\_\_\_
- (F) DOD Trunks ..... \_\_\_\_\_
- (G) Off Premises Extensions ..... \_\_\_\_\_
- (H) Release Link Trunks ..... \_\_\_\_\_
- (I) Future Growth ..... \_\_\_\_\_

PEC  
 TOTAL PORTS \_\_\_\_\_ ÷ 23/24\* = \_\_\_\_\_ 63156

\* A ÷ 24, B & C ÷ 23; a common circuit pack cannot be used for both AVD and DMI.

† A ÷ 24, B, C, & D ÷ 23; a common circuit pack cannot be used for AVD, DMI, and ISDN.

**32-CHANNEL E1 TRUNK (TN464 - For International DEFINITY G1 and G3r)**

Enter the number of:

- (A) Voice Grade Data Tie Trunks \* ..... \_\_\_\_\_
- (B) Alternate Voice/Data Tie Trunks \* ..... \_\_\_\_\_
- (C) DMI Tie Trunks \* ..... \_\_\_\_\_
- (D) ISDN PRI Trunks \* ..... \_\_\_\_\_
- (E) DID Trunks..... \_\_\_\_\_
- (F) DIOD Trunks ..... \_\_\_\_\_
- (G) DOD Trunks..... \_\_\_\_\_
- (H) Off Premises Extensions ..... \_\_\_\_\_
- (I) Release Link Trunks ..... \_\_\_\_\_
- (J) Future Growth..... \_\_\_\_\_

TOTAL PORTS \_\_\_\_\_ ÷ 30/32\* = \_\_\_\_\_ 638041  
PEC

**Note:** 30 channels can be used for voice or data when one channel is used for inbound signaling and one for frame alignment and network management. In situations where no inbound signaling channel is required, 31 channels can be used for voice or data.

---

\* A ÷ 32, B, C, & D ÷ 30 or 31; a common circuit pack cannot be used for AVD, DMI, and ISDN.

**HYBRID LINE (TN762)**

Enter the number of:

- (A) 7303S Terminals ..... \_\_\_\_\_
- (B) 7305S Terminals ..... \_\_\_\_\_
- (C) 7302H Terminals..... \_\_\_\_\_
- (D) 7303H Terminals..... \_\_\_\_\_
- (E) 7305H01B Terminals (4122) administered as 7305S Terminals ..... \_\_\_\_\_
- (F) 7305H02B Terminals (4170) administered as 7305S Terminals ..... \_\_\_\_\_
- (G) 7305H03B Terminals ..... \_\_\_\_\_
- (H) Future Growth ..... \_\_\_\_\_

PEC  
TOTAL PORTS \_\_\_\_\_ ÷ 8 = \_\_\_\_\_ 63113

**ANNOUNCEMENT (TN750)**

Enter the number of:

- (A) Announcement Ports..... \_\_\_\_\_
- (B) Future Growth ..... \_\_\_\_\_

PEC  
TOTAL PORTS \_\_\_\_\_ ÷ 16 = \_\_\_\_\_ 63141

**Note:** Only one TN750 circuit pack per system. The TN750 circuit pack should only be used in the Control Carrier which provides battery backup and reduces the chance of losing the announcements.

**POOLED MODEM (TN758)**

Enter the number of:

- (A) Pooled Modems ..... \_\_\_\_\_
- (B) Pooled Modems for growth..... \_\_\_\_\_

PEC  
TOTAL PORTS \_\_\_\_\_ ÷ 2 = \_\_\_\_\_ 63119



**MET LINE (TN735)**

Enter the number of METs:

- (A) 10 Button ..... \_\_\_\_\_
- (B) 20 Button ..... \_\_\_\_\_
- (C) 30 Button ..... \_\_\_\_\_
- (D) Future Growth ..... \_\_\_\_\_

TOTAL PORTS \_\_\_\_\_ ÷ 4 = \_\_\_\_\_ PEC  
63112

**SPEECH SYNTHESIZER (TN725)**

Enter the number of:

- (A) Speech Synthesizer Ports ..... \_\_\_\_\_
- (B) Future Growth ..... \_\_\_\_\_

TOTAL PORTS \_\_\_\_\_ ÷ 4 = \_\_\_\_\_ PEC  
63128

**TIE TRUNK (ANALOG) (TN760)**

Enter the number of:

- (A) Tie Trunks (Including Release Link Trunks) ..... \_\_\_\_\_
- (B) Future Growth ..... \_\_\_\_\_

TOTAL PORTS \_\_\_\_\_ ÷ 4 = \_\_\_\_\_ PEC  
63117

**tone clock (TN768)**

For G1 and G3, Tone Clock TN768 is always required instead of TN741 or TN714. G1 and G3 multi-carrier cabinets ship with a TN768 as part of the basic PEC. G1 single-carrier cabinets ship with a TN756 as part of the basic PEC. When a G1 single-carrier cabinet system has the duplication option, EPN, DS1 service, or OCM, a TN768 Tone Clock (PEC 65515) is required.

When either a TN741 or TN768 is used, the Tone Detector must be the TN748.

**tone clock (TN780)**

The TN780 connects and monitors an optional external Stratum 3 clock. The TN780 also couples the Stratum 3 clock's output to local clocks. Only the processor carrier, which supplies master timing to the system, uses this circuit pack. The TN780 provides the following tones: call progress, touch tones, answer-back, and trunk transmission test. It also provides the following clocks: 2MHz, 160kHz, and 8kHz. This circuit pack can transmit the system clock and tones on either TDM bus A, TDM bus B, or both buses.

**tone detector (TN748)**

Two Call Progress Tone Receiver (CPTR) ports are provided on each TN748 Tone Detector circuit pack alongside the four Touch-Tone Receiver ports. CPTRs are required to provide dial tone detection for the enhanced Automatic Route Selection, Terminal Dialing, Abbreviated Dialing, and Last Number Dialed features. High usage of Terminal Dialing to locations outside the system may require a greater number of CPTRs and should be referred to your Technical Service Center (TSC) for review.

Note that up to 20 TN748s may be used in G1 systems, up to 10 in G3i systems, and up to 50 in G3r systems.

In the following calculations, do **not** include TN748s that are provided as standard equipment.

**Note:** For G1 single-carrier systems, the TN768 Tone Clock circuit pack is used instead of the TN756 Tone Detector/Generator circuit pack when the duplication option, DS1 Tie Trunk (TN722), or DS1 Interface (TN767) circuit packs or ISDN-PRI is used.

Enter the number of:

(A) Touch-Tone Receivers ..... \_\_\_\_\_

SUBTOTAL A ÷ 4 = \_\_\_\_\_

(B) Call Progress Receivers ..... \_\_\_\_\_

SUBTOTAL B ÷ 2 = \_\_\_\_\_

PEC  
ENTER LARGER OF SUBTOTALS \_\_\_\_\_ 63123

**TABLE M. Summation of Interface Circuit Packs**

<b>Circuit Pack</b>	<b>Description</b>	<b>PEC</b>	<b>Quantity</b>
TN429 (Int'l Only)	DIOD Dialing Trunk	63802I	
TN464 (Int'l and G3r)	32-Channel E1 Trunk	63804I	
TN465 (Int'l Only)	CO Loop Start Trunk	63801I	
TN479 (Int'l Only)	Analog Line	63803I	
TN553	Packet Data Line	63318	
TN556	ISDN-BRI Line	65512	
TN577	Packet Gateway	63317	
TN722	DS1 Tie Trunk	63122	
TN725	Speech Synthesizer	63128	
TN726	Data Line	63130	
TN735	MET Line	63112	
TN741	Tone Clock	63127	
TN744	Call Classifier	63532	
TN746	Analog Line (16)	63136	
TN747	CO Trunk	63115	
TN748	Tone Detector	63123	
TN750	Announcement	63141	
TN753	DID Trunk	63116	
TN754	Digital Line	63114	
TN758	Pooled Modem	63119	
TN760	Tie Trunk	63117	
TN762	Hybrid Line	63113	
TN763	Auxiliary Trunk	63118	
TN765	Processor Interface	63153	
TN767	DS1 Interface	63156	
TN768	Tone Clock	65515	
TN780 (Int'l Only)	Tone Clock	63137	
TN574	DS1 Converter	63327	
TOTAL CIRCUIT PACKS			

## Software Determination

Table N provides a listing of system software PEC codes.

**TABLE N. System Software PEC Codes**

Description	G1 PEC	G3i PEC	G3r PEC
<b>Basic Voice Applications Software</b> (always required)	<b>1233VAS</b>	<b>1236VAS</b>	<b>1263VAS</b>
CallVisor Adjunct Switch Application Interface		1236ASB	1263ASB
Authorization Codes	1233AUC	1236AUC	1263AUC
Automatic Call Distribution	1233ACD	1236ACD	1263ACD
Automatic Route Selection	1233AR	1236AR	1263ARS
Basic Call Management System Measurements	1233BCM	1236BCM	1263BCM
Call Vectoring Basic		1236CVB	1263CVB
Call Vectoring Prompting		1236CVP	1263CVP
Call Work Codes		1236CWC	1263CWC
Centralized Attendant Service (Branch)	1233CAS	1236CAS	1263CAS
Centralized Attendant Service (Main)	1233CAM	1236CAM	1263CAM
Distributed Communications System	1233DCS	1236DCS	1263DCS
Emergency Access to Attendant	1233VAS	1236VAS	1263VAS
Enhanced Abbreviated Dialing	1233EAD	1236EAD	1263EAD
Forced Entry of Account Codes	1233FEA	1236FEA	1263FEA
Hospitality Services	1233VAS	1236VAS	1263VAS
ISDN-PRI		1236PRI	1263PRI
Look Ahead Interflow		1236LAI	1263LAI
SID/ANI	1233PRI		
circuit packN/BN		1236PRI	1263PRI
Private Networking (AAR)	1233PNA	1236PNA	1263PNA
Service Observing	1233VAS	1236VAS	1263VAS
Uniform Dial Plan	1233UDP	1236UDP	1263UDP

## Cabinet Determination (DEFINITY Generic 1 and Generic 3)

DEFINITY Communications Systems G1 and G3 have a duplication option for the control cabinet (that is, control circuits are duplicated). These systems also have an option for duplicating the expansion cabinet (that is, a second port cabinet can be added). A DEFINITY system is ordered according to the need for duplication, the number of ports required, and future growth expectations.

For DEFINITY systems with multi-carrier cabinet(s), the cabinet that contains the control circuits (duplicated or unduplicated) is called the Processor Port Network (PPN). The PPN provides up to 89 port slots. If a second cabinet is required for additional ports, the cabinet is referred to as an Expansion Port Network (EPN).

**Note:** For G3r, the PPN is only supported by the multi-carrier cabinet. EPNs in G3r can use the single-carrier cabinets.

In a DEFINITY system with single-carrier cabinet(s), the stack of one to four cabinets that includes the control circuits is called the PPN (G1 and G3i only). The PPN also contains up to 64 port slots. If an additional stack of one to four cabinets is required, the stack is referred to as an EPN.

G1 and G3i systems that contain both a PPN and an EPN must be connected by way of expansion interface circuits located in port slots in the PPN and EPN using fiber-optic cables.

The G3r uses a Center Stage Switch (CSS) for interconnections when there are four or more port networks (PPNs and EPNs). In this case, each port network's TN570 Expansion Interface and fiber module is connected by fiber-optic cable to a TN573 Switch Node Interface in a switch node. The CSS can consist of multiple switch nodes, in which case those switch nodes are interconnected by fiber-optic cables. When there are fewer than four port networks, the PPNs and EPNs are connected in the same fashion as for G1 and G3i. You can have a CSS for fewer than four port networks, but it is not recommended unless you anticipate expanding the system to four or more port networks. The TN573 Switch Node Interface circuit packs are usually installed in the E Carrier of the PPN.

**Note:** Although port networks can be interconnected using fiber-optic cable for G3r in the same fashion as for G1 and G3i, it is more cost-effective and it is required, where there are four or more port networks involved, to use the CSS.

The mixing of multi-carrier and single-carrier cabinets in an equipment configuration is allowed. For example, a fully equipped multi-carrier PPN that requires a few additional ports can be supplemented by one single-carrier EPN cabinet. Such an arrangement would be more economical than adding a multi-carrier EPN cabinet equipped with only one carrier.

### Multi-Carrier Cabinet Configuration

A multi-carrier cabinet configuration can be selected from the following equipment arrangements. The G3r data is given in the following table separately from the G1 and G3i data.

The G3r data has special considerations and limitations:

- The PPN cabinet is the first cabinet and is available only in the multi-carrier cabinet.
- The PPN cabinet supports only one port network.
- The PPN cabinet is configured with three different carriers:
  - Processor Carrier - Minimum of one, maximum of two
  - Switch Node Carrier - One or two, depending on connectivity duplication
  - Port Carrier - Minimum of one, maximum of four
- The Switch Node Carrier can only be configured in a multi-carrier cabinet.
- The EPN is available in both the single- and multi-carrier cabinet.

Carriers	Max Port Slots*	PEC	Attribute for AC	Attribute for DC
<b>PPN Without Duplication</b>				
Control A + Port B	29 (28)	6300-05A	PRC02	PRC04
Control A + Ports B, C	49 (48)	6300-05B	PRC02	PRC04
Control A + Ports B, C, D	69 (68)	6300-05C	PRC02	PRC04
Control A + Ports B, C, D, E	89 (88)	6300-05D	PRC02	PRC04
G3r Control A + Ports B, C, D, E (No CSS)	80	6300-07D	PRC02	PRC04
G3r Control A + Ports B, C, D (E - With CSS)	60	6300-07C 63310	PRC02	PRC04
<b>EPN Without Duplication (adds to PPN)</b>				
Expansion Control A	18	63501		
Exp. Control A + Port B	38	63502	PRC02	PRC04
Exp. Control A + Ports B, C	58	63503	PRC02	PRC04
Exp. Control A + Ports B, C, D	78	63504	PRC02	PRC04
Exp. Control A + Ports B, C, D, E	98	63505	PRC02	PRC04
G3r Control A + Ports B, C, D, E (No CSS)	98	63505	PRC02	PRC04
G3r Control A + Ports B, C, D, E (With Simplex Switch Node Carriers)	78	63505	PRC02	PRC04
G3r Control A + Ports B, C, D, E (With Duplicate Switch Node Carriers)	58	63505	PRC02	PRC04

\* Figures in ( ) are maximum PPN slots when the system has EPN.

## HARDWARE AND SOFTWARE DETERMINATION

Carriers	Max Port Slots*	PEC	for AC	Attribute for DC
<b>PPN With Duplication</b>				
Duplication Equipment		63201		
Control A + Dup. Control B	18 (16)	6300-05A	PRC03	PRC05
Control A + Dup. B + Port C	38 (36)	6300-05B	PRC03	PRC05
Control A + Dup. B + Ports C, D	58 (56)	6300-05C	PRC03	PRC05
Control A + Dup. B + Ports C, D, E	78 (76)	6300-05D	PRC03	PRC05
G3r Control A + Dup. B + Ports B, C, D, E (No CSS)	60	6300-07D	PRC03	PRC05
G3r Control A + Dup. B + Ports B, C, D (E-With CSS, Dup. Processor Only)	40	6300-07C	PRC03	PRC05
G3r Control A + Dup. B + Ports B, C, D (E-With CSS, Fully Dup.)	40	6300-07C	PRC03	PRC05
<b>EPN With Duplication (adds to PPN)</b>				
Duplication Equipment		63202		
Exp. Control A + Port B	36	63502	PRC03	PRC05
Exp. Control A + Ports B, C	56	63503	PRC03	PRC05
Exp. Control A + Ports B, C, D	76	63504	PRC03	PRC05
Exp. Control A + Ports B, C, D, E	96	63505	PRC03	PRC05
G3r Control A + Ports B, C, D, E (Two port networks, port network above fans)	59	63505	PRC03	PRC05
G3r Control A + Ports B, C, D, E (Two port networks, port network below fans)	40	63505	PRC03	PRC05

\* Figures in ( ) are maximum PPN slots when the system has EPN.

### Single-Carrier Cabinet Configuration

A single-carrier cabinet configuration can be selected from the following equipment arrangements. The G3r data is given in the following table separately from the G1 and G3i data.

**Note:** The G3r PPN is only available as a multi-carrier cabinet. The G3r EPN is, however, available in single-carrier cabinets.

Cabinets	Max Port Slots*	PEC	Attribute
<b>PPN Without Duplication</b>			
Control A	10 (9)	6300-06A	TNC01-D
Control A + Port B	28 (27)	6300-06B	PRC02-D TNC01-D
Control A + Ports B, C	46 (45)	6300-06C	PRC02-D TNC01
Control A + Ports B, C, D	64 (63)	6300-06D	PRC02-D TNC01
<b>EPN Without Duplication (adds to PPN)</b>			
Expansion Control A	16	63601	PRC02-D
Exp. Control A + Port B	34	63602	PRC02-D
Exp. Control A + Ports B, C	52	63603	PRC02-D
Exp. Control A + Ports B, C, D	70	63604	PRC02-D
G3r Expansion Control A	17	63601	PRC02-D
G3r Exp. Control A + Port B	35	63602	PRC02-D
G3r Exp. Control A + Ports B, C	53	63603	PRC02-D
G3r Exp. Control A + Ports B, C, D	71	63604	PRC02-D
<b>PPN With Duplication</b>			
Duplication Equipment		63201	
Control A + Dup. Control B	20 (18)	6300-06B	PRC03 TNC02
Control A + Dup. Control B + Port C	38 (36)	6300-06C	PRC03 TNC02
Control A + Dup. Control B + Ports C, D	56 (54)	6300-06D	PRC03 TNC02
<b>EPN With Duplication (adds to PPN)</b>			
Duplication Equipment		63202	
Exp. Control A + Port B	32	63602	PRC03
Exp. Control A + Ports B, C	50	63603	PRC03
Exp. Control A + Ports B, C, D	68	63604	PRC03

\* Figures in ( ) are maximum PPN slots when the system has EPN.



## Ordering Information

Enter the quantities of equipment to be ordered on the Order Summary Sheet which follows (make additional copies of the sheet if needed). The sheets, when completed, can be attached to the order. Use the information listed on the various tables in the manual to complete the entries.

To ensure all equipment and facilities are ordered, complete the following checklist.

Are the following pieces of equipment/facilities required and have they been ordered or addressed?

	<b>Required</b>		<b>Ordered</b>	
	<b>Yes</b>	<b>No</b>	<b>Yes</b>	<b>No</b>
DEFINITY cabinet(s) (1 required)	<input type="checkbox"/>	<input type="checkbox"/>	<input type="checkbox"/>	<input type="checkbox"/>
Circuit packs (required)	<input type="checkbox"/>	<input type="checkbox"/>	<input type="checkbox"/>	<input type="checkbox"/>
System adjuncts (See Note 1)	<input type="checkbox"/>	<input type="checkbox"/>	<input type="checkbox"/>	<input type="checkbox"/>
Attendant Console(s)	<input type="checkbox"/>	<input type="checkbox"/>	<input type="checkbox"/>	<input type="checkbox"/>
Manager I Terminal(s) (G1)	<input type="checkbox"/>	<input type="checkbox"/>	<input type="checkbox"/>	<input type="checkbox"/>
G3-Management Terminal(s) (G3)	<input type="checkbox"/>	<input type="checkbox"/>	<input type="checkbox"/>	<input type="checkbox"/>
Terminals (voice & data) (See Note 2)	<input type="checkbox"/>	<input type="checkbox"/>	<input type="checkbox"/>	<input type="checkbox"/>
Terminal adjuncts (See Note 3)	<input type="checkbox"/>	<input type="checkbox"/>	<input type="checkbox"/>	<input type="checkbox"/>
Trunk facilities (local & special)	<input type="checkbox"/>	<input type="checkbox"/>	<input type="checkbox"/>	<input type="checkbox"/>
Network Interface	<input type="checkbox"/>	<input type="checkbox"/>	<input type="checkbox"/>	<input type="checkbox"/>
Switch/Terminal wiring, cable access panel, power failure transfer arrangements (Contact Premises Service Consultants)	<input type="checkbox"/>	<input type="checkbox"/>	<input type="checkbox"/>	<input type="checkbox"/>

**Notes:**

1. System Adjuncts: Printers, Local Storage Units, Queue Warning Lamps, Adjunct Processors, Call Detail Recorders, TELESEER CDR
2. Terminals: Voice Terminals (2500, 7100, 7300, 7400D Series, and CallMaster-602A1) Data Terminals, Data Sets, Data Modules (PDM/MPDM, TDM/MTDM, 7400A, 7400B, 7500B, BCTs, Z3A-ADU)
3. Terminal Adjuncts: Cords, Speakerphones, Modules (DDM, FKM, CCM, DTDM), DC power for modules, Amplifier handsets, Headsets/Adapters)



## ENVIRONMENTAL REQUIREMENTS

### General

This section provides information about the floor and wall space required for system and associated peripheral equipment installed in the equipment room. Specifications for temperature, humidity, air purity, and lighting levels are also included.

### Floor Plans and Layouts

Floor plan arrangements will vary depending on the size and shape of the equipment room and the amount of growth planned for the system. Typical floor plans are shown in Figures 10, 11, 12, and 13. DEFINITY Generic 1 and DEFINITY Generic 3 can have either one system cabinet (PPN) or two system cabinets (PPN and EPN) plus an auxiliary cabinet in some cases.

The wall behind the system cabinet must be clear of all objects (pictures, shelves, or windows) that are not required in the system installation. The entire area behind the cabinet must be reserved for the cross-connect field and the cable access panel (when provided). Also, room for system growth should be considered.

### Floor Loading

The type of system cabinet determines the floor loading requirement.

#### With Multi-Carrier Cabinet(s)

The floor must have a commercial floor loading code of at least 50 pounds per square foot. A fully loaded multi-carrier cabinet weighs about 800 pounds. Thus, a free maintenance area of at least 16 square feet is required for each cabinet.

#### With Single-Carrier Cabinet(s)

One single-carrier cabinet weighs about 130 pounds, a fully loaded two-cabinet system weighs about 255 pounds, a fully loaded three-cabinet system weighs about 380 pounds, and a four-cabinet system weighs about 500 pounds. Since the floor must have a commercial floor loading code of at least 50 pounds per square foot, a free maintenance area of at least 10 square feet is required for a four-cabinet system.

## Earthquake Protection

When earthquake or disaster bracing is required by law, or when local engineering feels that bracing is necessary, the system cabinet can be bolted to the floor. Figure 14 shows the zones in the North American continent where bracing may be desirable.

**Note:** A greater susceptibility of an area to earthquakes is indicated by a higher number in Figure 14. In the United States, 0 represents the lowest susceptibility and 4 represents the highest. In Canada, 0 represents the lowest susceptibility and 3 represents the highest.

Refer to the *DEFINITY® Communications System Generic 1 and Generic 3—Installation and Test*, 555-230-104 manual for details regarding the installation of earthquake bracing.

## Floor Space

The floor space requirements in the equipment room vary for each system.

### With Single-Carrier Cabinet(s)

The following system equipment and optional peripheral equipment occupies floor space in the equipment room (Figure 10):

- System Cabinet and Cable Slack Manager—The system cabinet is 27 inches wide and 22 inches deep. A single cabinet is about 20 inches high, a two-cabinet system is 39 inches high, a three-cabinet system is 58 inches high, and a four-cabinet system is 77 inches high. The cable slack manager requires 38 inches between the cabinet and wall. The system cabinets and cable slack manager occupy about 8 square feet of floor space.

### With Multi-Carrier Cabinet(s)

The following system equipment and optional peripheral equipment occupies floor space in the equipment room (Figures 11, 12, and 13):

- System Cabinet and Cable Slack Manager—The system cabinet is 32 inches wide and 28 inches deep. The cabinet is 70 inches high. The cable slack manager requires 38 inches between the cabinet and wall. Each cabinet (including the door opening) and cable slack manager occupy about 22 square feet of floor space.
- Auxiliary Cabinet—The auxiliary cabinet is 32 inches wide, 24 inches deep, and 70 inches high. This cabinet (including the door opening and maintenance area behind the cabinet) occupies about 22 square feet of floor space.

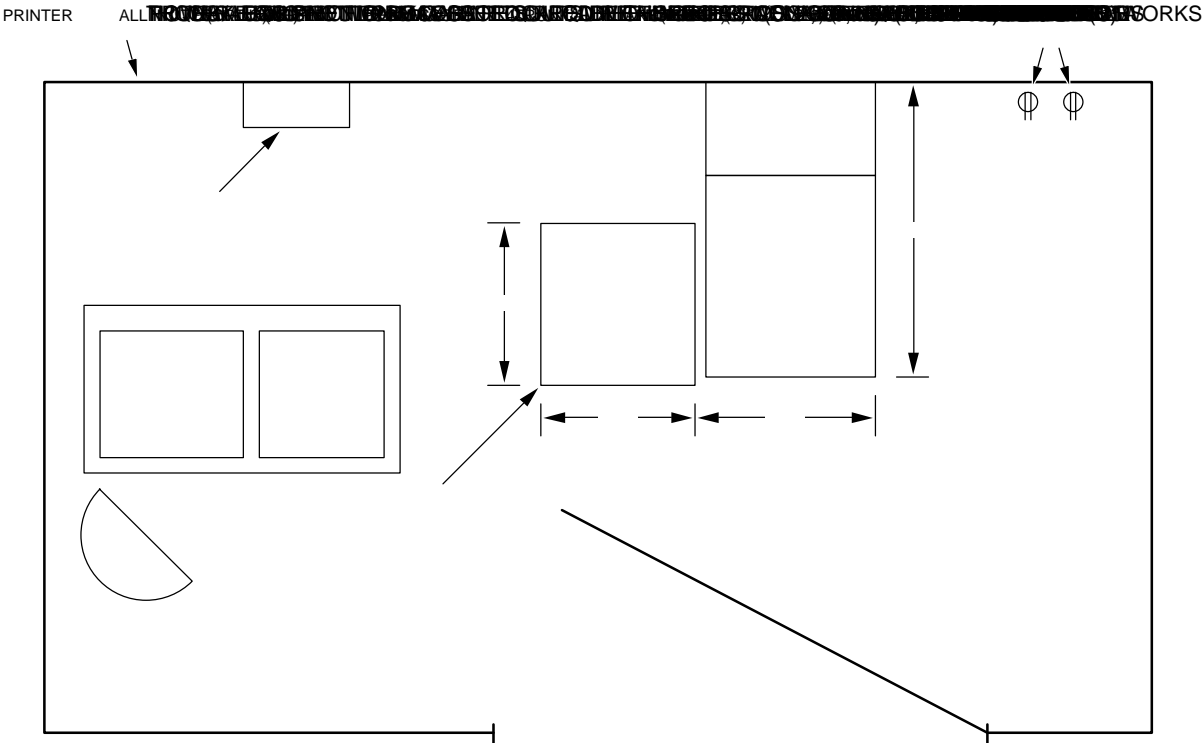

2" ABLE40" T 22" 27"

FIGURE 10. Typical Single-Carrier Cabinet Floor Plan With Processor Port Network Only

PRINTER ■ ALL RIGHTS RESERVED ■ DOCUMENT

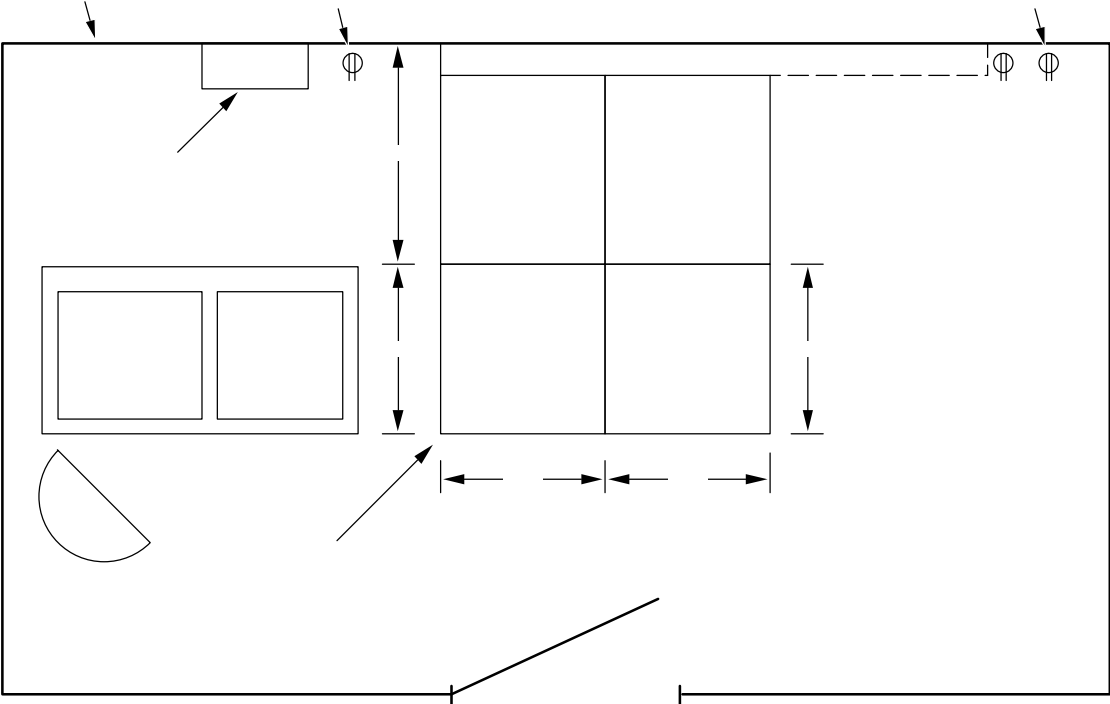

**FIGURE 11. Typical Multi-Carrier Cabinet Floor Plan With Processor Port Network and Auxiliary Cabinet**

PRINTER 5. ALL RIGHTS RESERVED. DOCUMENT

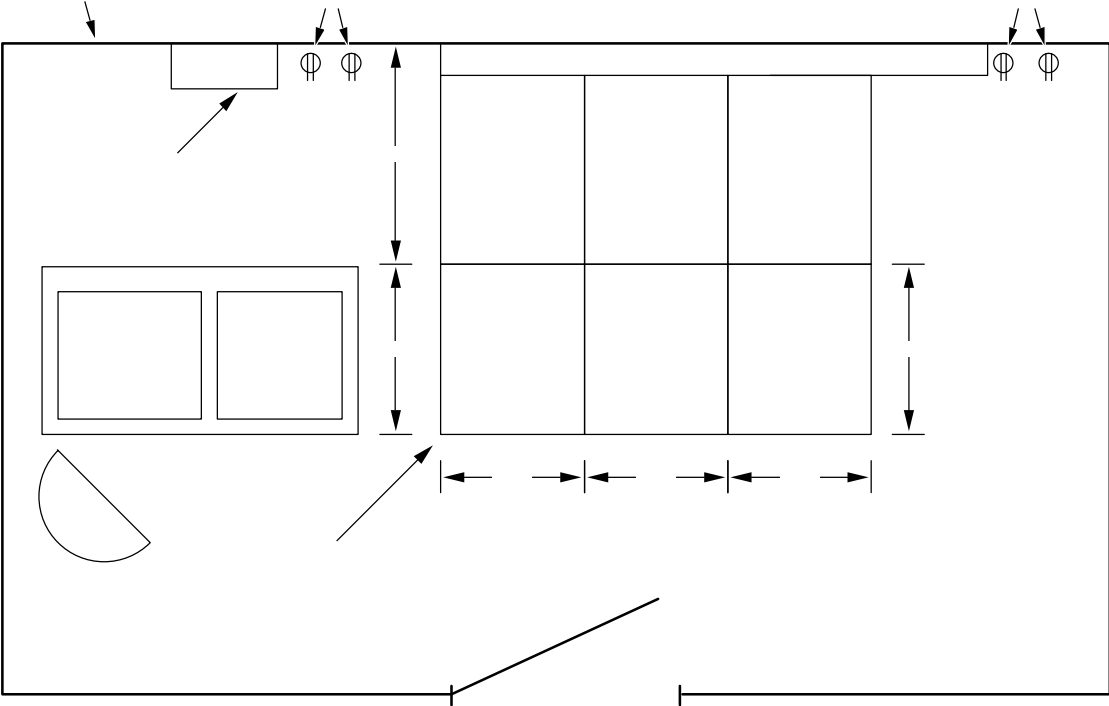

FIGURE 12. Typical Floor Plan With Processor and Expansion Port Networks

PRINTER 5. ALL RIGHTS RESERVED. DOCUMENT

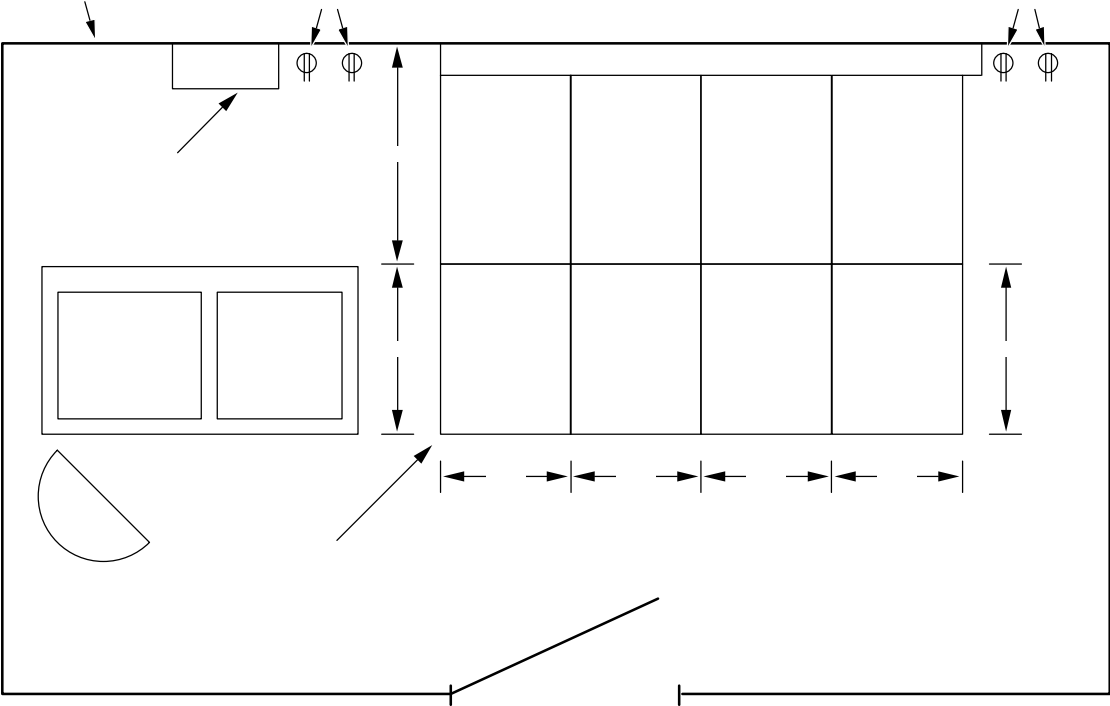

FIGURE 13. Typical Floor Plan With Processor and Expansion Port Networks (G3r Only)



SEISMIC RISK ZONE MAPS

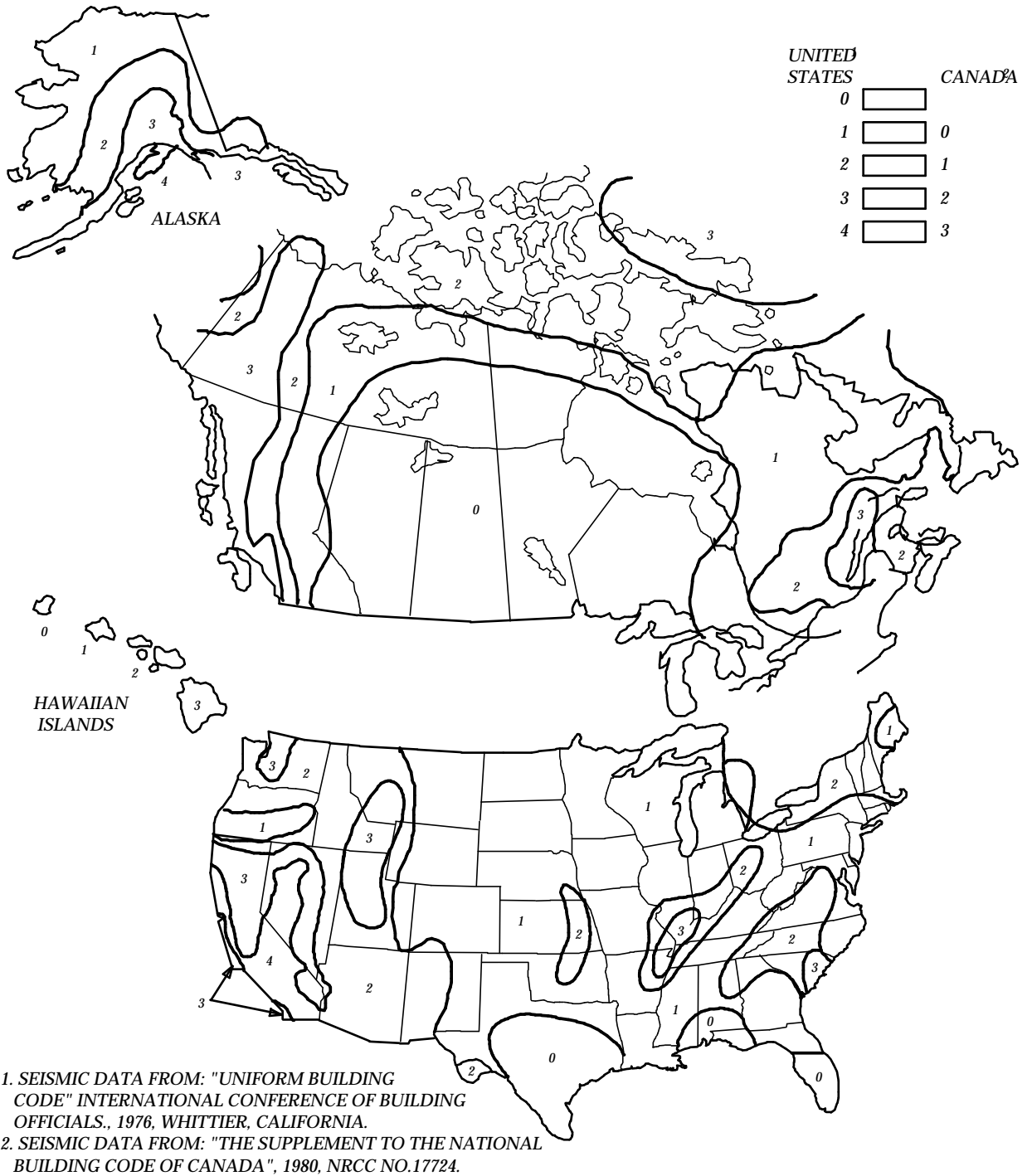

FIGURE 14. Earthquake Environment (North American Continent)

### Desktop Space

The 510A or 510D Personal Terminal and 513, 515, 610, 615, 715, 4410, and 4425 terminals can be located in the equipment room and require space on a desk or table.

The 513, 515, 610, 615, 715, 4410, and 4425 terminals each require approximately 3.2 square feet of space. The 510A or 510D with optional keyboard each requires approximately 2.1 square feet of space.

### Optional Equipment Floor and Desktop Space

Refer to the following documents for additional information on optional equipment that can be used with the system and that will require floor or desk space.

445 Printer	999-700-023
443 Printer	999-700-024
450 Printer	999-700-025
460 Printer	999-700-022
470 Printer and 475 Printer	999-300-285IS
572 Printer and 573 Printer	999-300-562

### Wall Space Required

Wall space required in the equipment room depends on the type of cross-connect equipment being installed—Z100-type (modular) or 110-type. The space required also depends on the size of the system. *DEFINITY® Communications System Generic 1 and Generic 3i—Wiring*, 555-204-111, provides details on the cross-connect hardware.

If existing cross-connect hardware is reused, the space requirements and hardware requirements must be detailed in the system floor plan. Contact the Technical Consultant for assistance in planning for reuse of existing equipment.

## Temperature and Humidity

The system equipment should be installed in a well-ventilated area. Maximum equipment performance is obtained at an ambient temperature between 40 and 120 degrees Fahrenheit (4 and 49 degrees Celsius) for short term operation and up to 110 degrees Fahrenheit (43 degrees Celsius) for continuous operation. The relative humidity range is 10 to 95 percent up to 84 degrees Fahrenheit (29 degrees Celsius). Above 84 degrees Fahrenheit (29 degrees Celsius), maximum relative humidity decreases from 95 percent down to 32 percent at 120 degrees Fahrenheit (49 degrees Celsius). Installations outside these limits may reduce system life or impede operation. Table O correlates room temperature with allowable relative humidity.

**TABLE O. Allowable Relative Humidity**

<b>Room Temperature</b>	<b>Allowable Relative Humidity</b>
40 °F to 84 °F	10% to 95%
86 °F	10% to 89%
88 °F	10% to 83%
90 °F	10% to 78%
92 °F	10% to 73%
94 °F	10% to 69%
96 °F	10% to 65%
98 °F	10% to 61%
100 °F	10% to 58%
102 °F	10% to 54%
104 °F	10% to 51%
106 °F	10% to 48%
108 °F	10% to 45%
110 °F	10% to 43%
112 °F	10% to 40%
114 °F	10% to 38%
116 °F	10% to 36%
118 °F	10% to 34%
120 °F	10% to 32%

The system equipment can operate at the maximum short-term operational limits for a period not to exceed 72 consecutive hours or a total of more than 15 days in a year. For altitudes above 5,000 feet, reduce the maximum short-term temperature limit by 1 °F for each 1,000 feet of elevation above 5,000 feet. At 10,000 feet, for example, the maximum short-term temperature limit is 115 °F.

### Air Purity

The cabinet should not be installed in an area where the air may be contaminated with any of the following:

- Excessive dust, lint, carbon particles, paper fiber contaminants, or metallic contaminants
- Corrosive gases, such as sulfur and chlorine

### Lighting

Lighting should be bright enough to allow administration and maintenance personnel to perform their tasks. The recommended light intensity level is 50 to 70 footcandles. This level complies with the Occupational Safety and Health Act (OSHA) standards.

### Noise

In most cases, electrical noise is introduced into the system through trunk or station cables, or both. However, electromagnetic fields near the system control equipment may also cause noise in the system. Therefore, the system and cable runs should not be placed in areas where a high electromagnetic field strength exists. Radio transmitters (AM or FM), television stations, induction heaters, motors (with commutators) of 0.25 horsepower (187 watts) or greater, and similar equipment are leading causes of interference. Small tools with universal motors are generally not a problem when they operate on separate power lines. Motors without commutators, whether synchronous or asynchronous, generally do not cause interference.

Field strengths below 1.0 volt per meter are unlikely to cause interference. These weak fields can be measured by a tunable meter such as the Model R-70 meter manufactured by Electro-Metrics Division.

Field strengths greater than 1.0 volt per meter can be measured with a broadband meter such as the HOLADAY™ HI-3001 meter or the Model EFS-1 meter manufactured by Instruments for Industry, Inc.

The field strength produced by radio transmitters can be estimated by dividing the square root of the emitted power in kilowatts by the distance from the antenna in kilometers. This yields the approximate field strength in volts per meter and is relatively accurate for distances greater than about half a wavelength (150 meters for a frequency of 1000 kHz).

---

## Additional Considerations

Noise and heat produced by the system also affect the selection of equipment location.

### Acoustic Noise Levels

The acoustic noise levels for the various cabinet configurations are described below.

#### With Multi-Carrier Cabinet(s)

The noise produced by a cabinet with five carriers is 51, 53, and 56 dBa at low, medium, and high fan speeds, respectively, at a distance of 5 feet.

**Note:** If the system cabinet door is open, there is an additional 1 dBa of noise. The tape drive also causes additional noise. When the tape drive is reading data, there is an additional 1 dBa of noise. When the tape recorder is rewinding or fast winding, there is an additional 2 dBa of noise.

#### With Single-Carrier Cabinet(s)

The noise produced by the system is as follows:

- One cabinet— 48 dBa at a distance of 5 feet
- Two cabinets— 50 dBa at a distance of 5 feet
- Three cabinets— 52 dBa at a distance of 5 feet
- Four cabinets— 53 dBa at a distance of 5 feet

**Note:** If the system cabinet door is open, there is an additional 1 dBa of noise. The tape recorder also causes additional noise. When the tape recorder is reading data, there is an additional 2 dBa of noise. When the tape recorder is rewinding or fast winding, there is an additional 4 dBa of noise.

### Heat Dissipation

The amount of heat dissipated by DEFINITY Generic 1 cabinet configurations is described below.

**With Multi-Carrier Cabinet(s)**

A fully-loaded multi-carrier cabinet (five carriers) dissipates approximately 8000 BTUs per hour. However, the typical average dissipation for a cabinet of three carriers is 5000 BTUs per hour.

**With Single-Carrier Cabinet(s)**

A stack of four single-carrier cabinets (fully loaded) dissipates approximately 6700 BTUs per hour. However, the typical average dissipation for a one-carrier system is 1700 BTUs per hour.

Table P shows the typical average and maximum system power consumption and also the system heat dissipation for different size SCC and MCC systems.

**TABLE P. System Power Consumption and Heat Dissipation**

Size	System Power Consumption (Volt-Ampere Rating)				System Heat Dissipation (BTU per Hour)			
	SCC		MCC		SCC		MCC	
	Avg	Max	Avg	Max	Avg	Max	Avg	Max
Tier 1	540	760	540	760	1700	-	-	-
Tier 2	1080	1376	1080	1376	3400	-	-	-
Tier 3	1620	1976	1620	1976	5100	-	-	-
Tier 4	2160	2584	2160	2584	6700	-	-	-
Tier 5	-	-	2700	3344	-	-	5000	8000

## POWER AND GROUNDING

### General

This section provides information on power, grounding, lightning protection, sneak current protection, standby power, and wiring requirements for system and associated peripheral equipment installed in the equipment room.

### AC Power Requirements

The following section provides AC power and grounding requirements for DEFINITY Generic 1 and Generic 3 systems.

#### Multi-Carrier Cabinet System

The customer must provide the main AC distribution panel (panel board). Any available power source can be used, as long as the phase or leg provides 120-volt AC or 208-volt AC between any two legs or phases at the required current drain. The panel board must be equipped with a bolt-on 50-amp 120-volt or 208-volt thermal magnetic circuit breaker for each cabinet. One of the following panel boards, or equivalent, can be provided:

- QMR fusible panel board by General Electric
- QMB fusible panel board by Square D
- VB5 fusible panel by ITE
- FPD fusible panel by Westinghouse

Each system cabinet, along with the auxiliary cabinet, requires a separate power outlet. These outlets must not be shared with other equipment, must not be under switch control, and should be located outside the cross-connect field area, if possible. Individual requirements are as follows:

- PPN cabinet and EPN cabinet—Each cabinet requires a special 120-volt 60-Hz 50-amp power outlet (NEMA 5-50R or equivalent) or a special 208-volt 60-Hz 30-amp power outlet (NEMA L6-30R or equivalent). The outlet must be located within 10 feet of the cabinet.
- Auxiliary Cabinet (optional)—This cabinet requires a special 120-volt 60-Hz 20-amp power outlet (NEMA 5-20R or equivalent) or a special 208-volt 60-Hz 30-amp power outlet (NEMA L6-30R or equivalent). The outlet must be located within 12 feet of the cabinets.

Figure 15 depicts a typical power and grounding layout for colocated PPN and EPN cabinets. A ground wire from the ground block on the EPN cabinet connects to the single-point ground block on the PPN cabinet. A 6-AWG ground wire connects the single-point ground block on the PPN cabinet to an approved ground. (Also see "Grounding," later in this section).

Note that the AC powering for a multi-carrier cabinet is as shown in Figure 15 for the PPN cabinet.

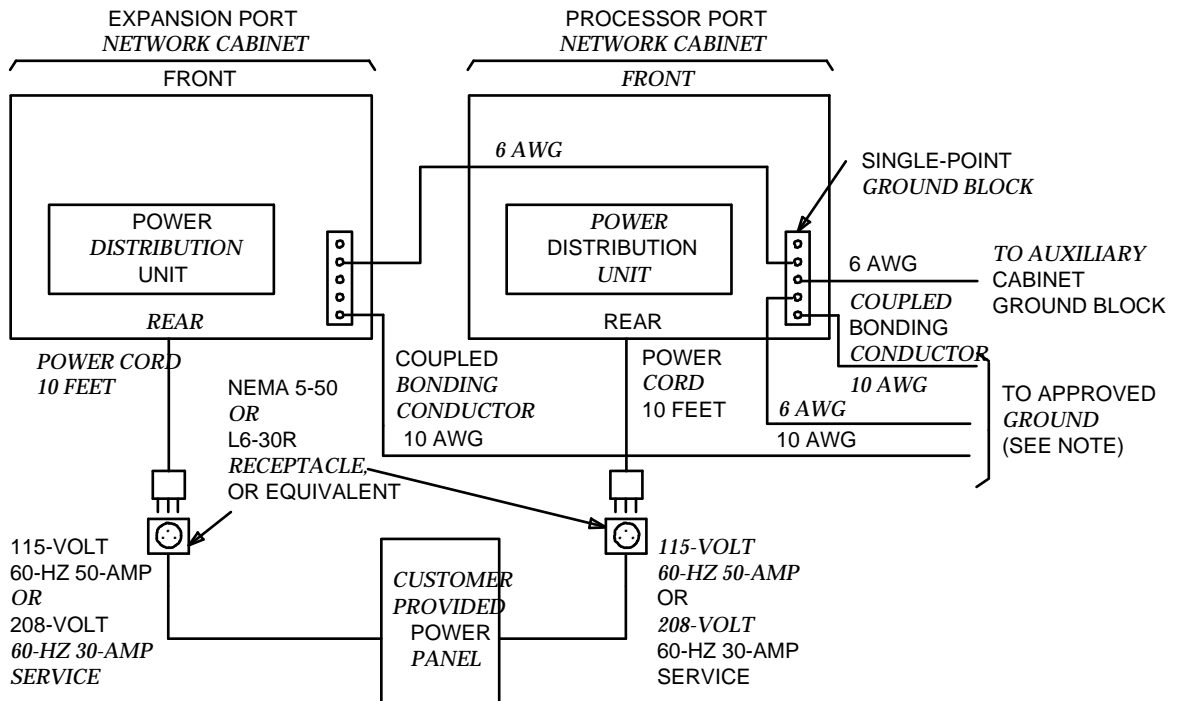

NOTE:  
 USE APPROVED GROUND LOCATED NEAREST THE  
 TELEPHONE COMPANY OWNED PROTECTOR GROUND BLOCK  
 AT THE BUILDING ENTRANCE FACILITY

FIGURE 15. Typical Multi-Carrier System AC Power and Grounding (EPN Colocated)



Figure 16 shows a typical power and grounding layout for a remotely located EPN cabinet. A ground wire must be connected from the cabinet ground block of both the PPN and EPN cabinets to an approved ground. (Also see "Grounding," later in this section).

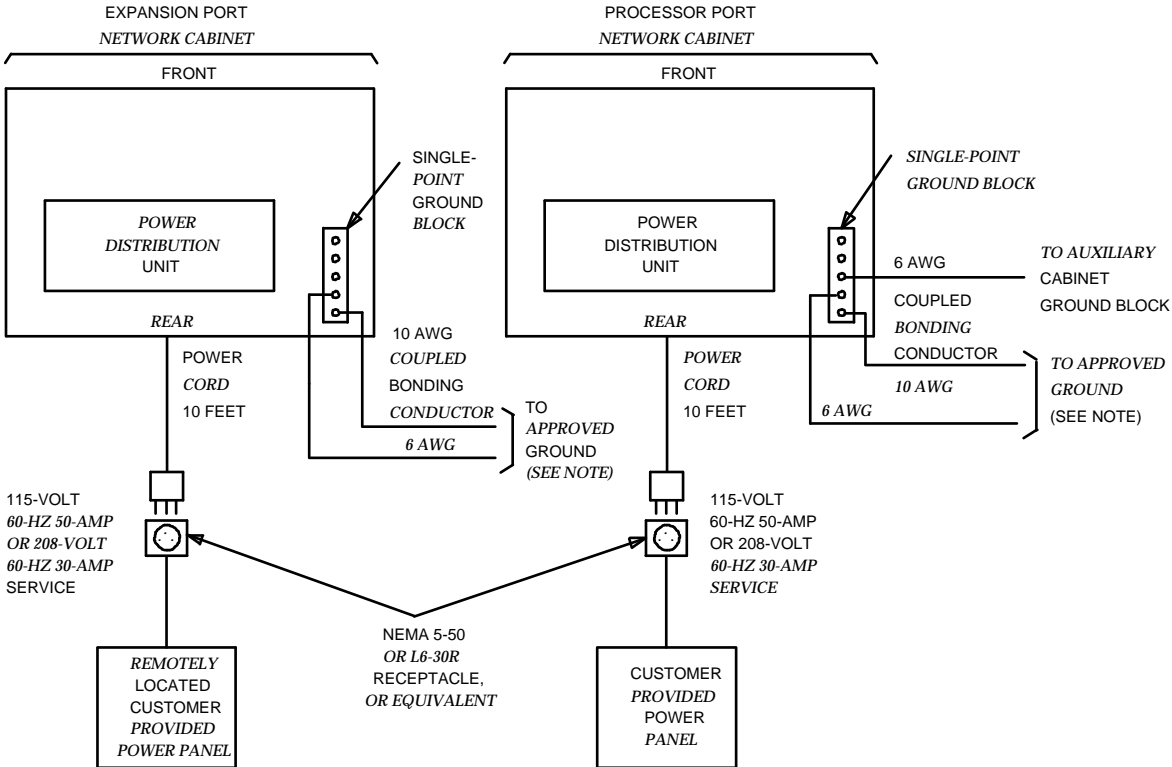

NOTE:  
USE APPROVED GROUND LOCATED NEAREST THE  
TELEPHONE COMPANY OWNED PROTECTOR GROUND BLOCK  
AT THE BUILDING ENTRANCE FACILITY

FIGURE 16. Typical Multi-Carrier AC Power and Grounding (Remote EPN)

### Single-Carrier Cabinet System

Each cabinet requires a separate power outlet, as shown in Figures 17 and 18. These outlets must not be shared with other equipment, must not be under switch control, and should be located outside the cross-connect field area, if possible. Any available power source can be used as long as the phase or leg provides 120-volt AC at the required drain.

The Manager I terminal or G3r-MT should be connected to the “Administration Terminal” power outlet, as shown in Figures 17 and 18.

A system cabinet is UL-listed at 10 amperes, 120 volts, or 1200 watts per cabinet. Therefore, the power required for a two-cabinet system is 2400 watts, the power required for a three-cabinet system is 3600 watts, and the power required for a four-cabinet system is 4800 watts.

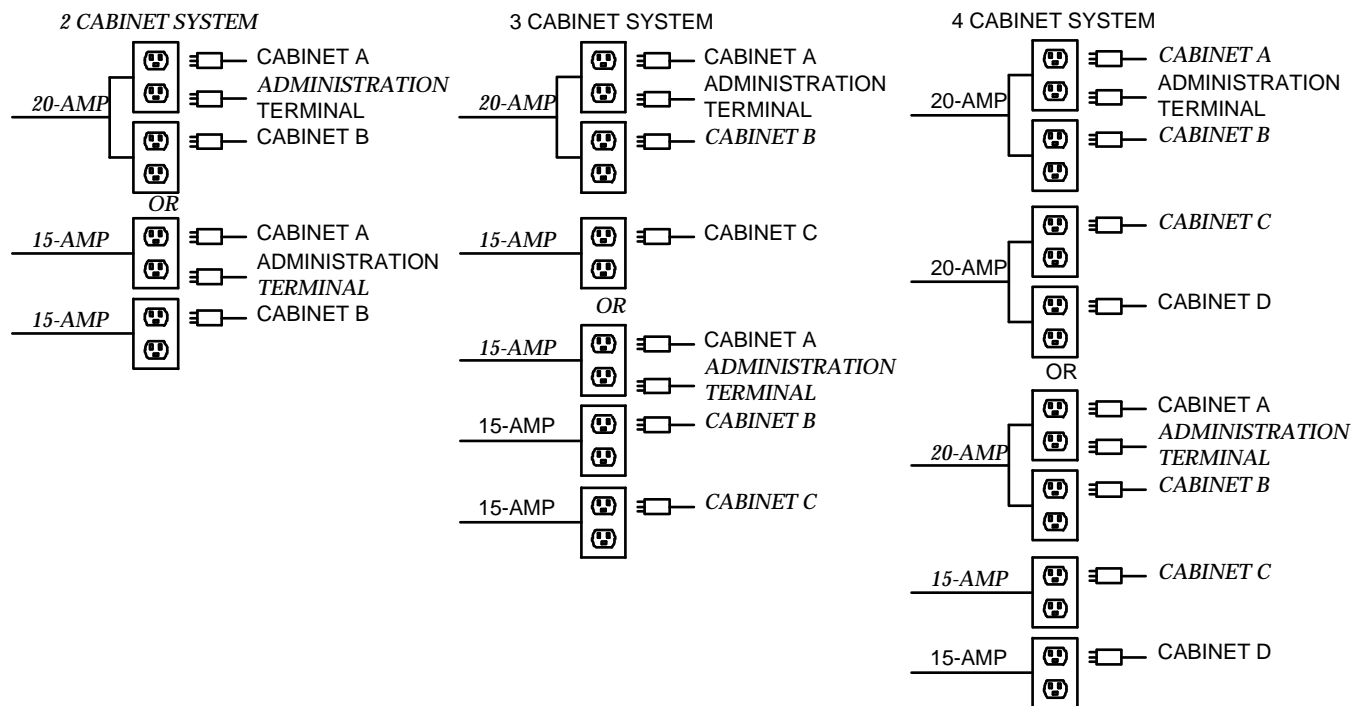

FIGURE 17. AC Power Requirements for a Single-Carrier Cabinet System

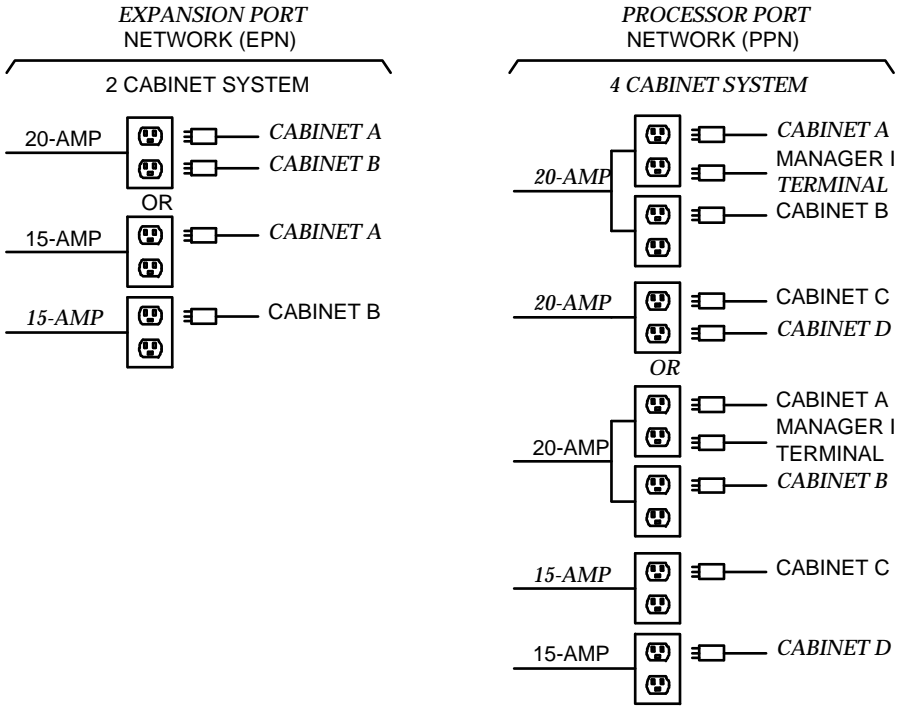
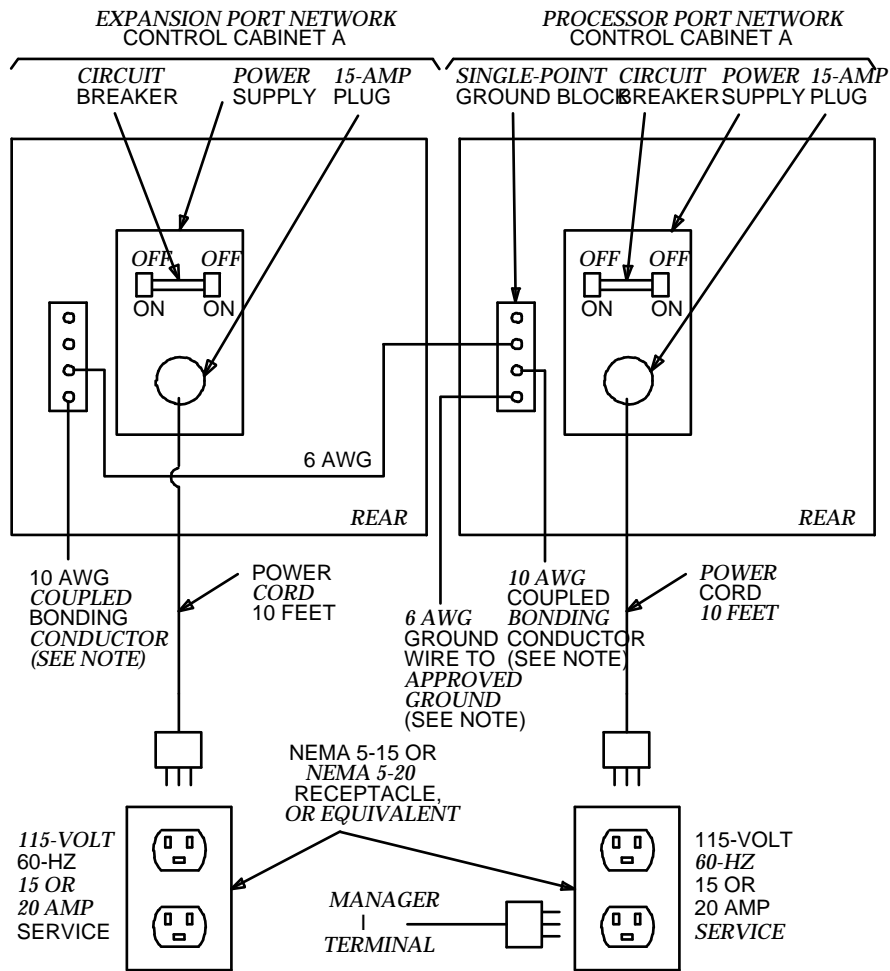

FIGURE 18. AC Power Requirements for a Single-Carrier System (Remotely Located EPN)

Figure 19 depicts a typical power and grounding layout for a single-carrier system with the PPN and EPN cabinets colocated. A ground wire from the ground block on the bottom cabinet of the EPN connects to the single-point ground block on the bottom cabinet of the PPN. A 6-AWG ground wire connects the single-point ground block to an approved ground. (Also see “Grounding,” later in this section).



NOTE:  
TO APPROVED GROUND LOCATED NEAREST THE TELEPHONE COMPANY OWNED  
PROTECTOR GROUND BLOCK AT THE BUILDING ENTRANCE FACILITY

FIGURE 19. Typical Single-Carrier Power and Grounding Layout (EPN Colocated)

Figure 20 shows a typical power and grounding arrangement for a system with the EPN remotely located. A ground wire must be connected from the cabinet ground block of both the PPN and EPN to an approved ground. (Also see "Grounding," later in this section).

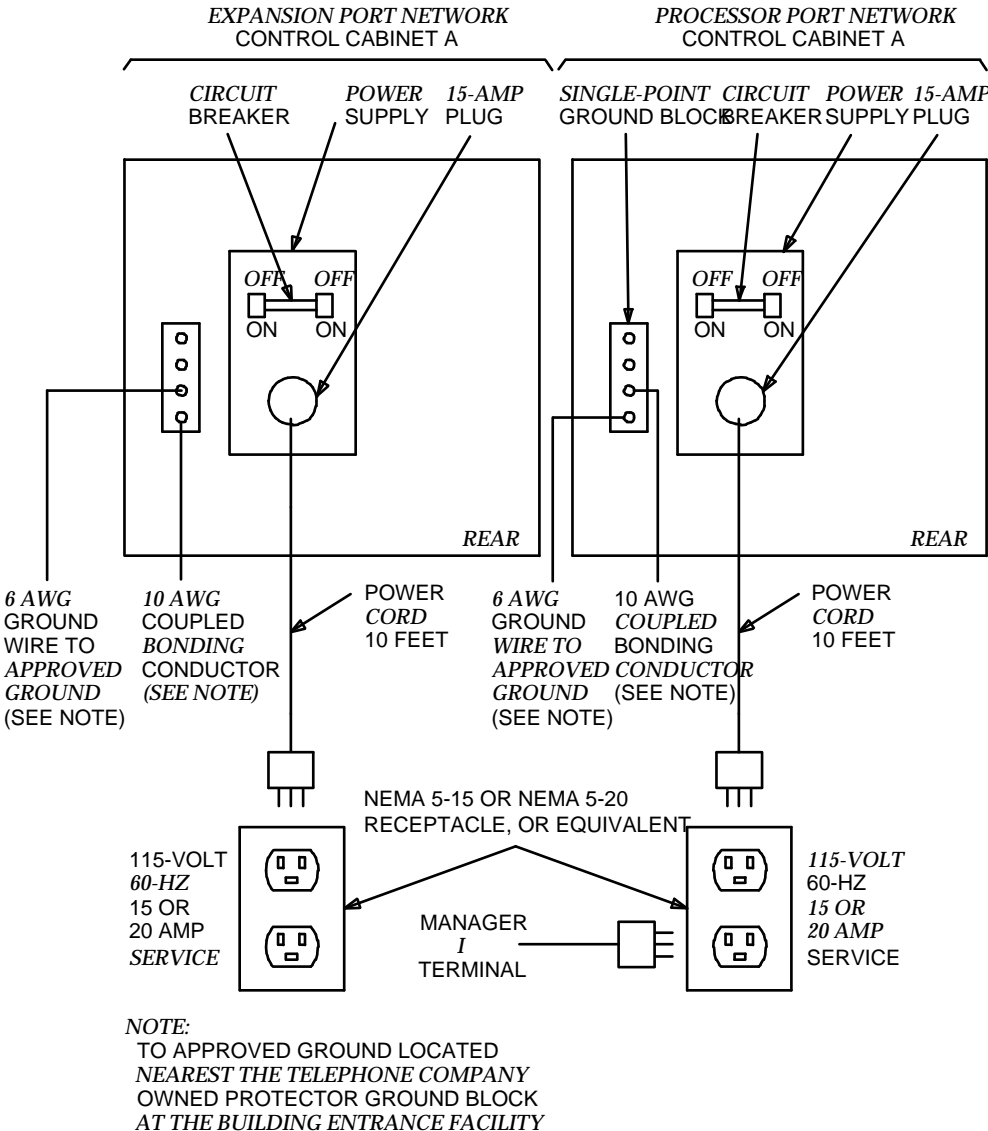
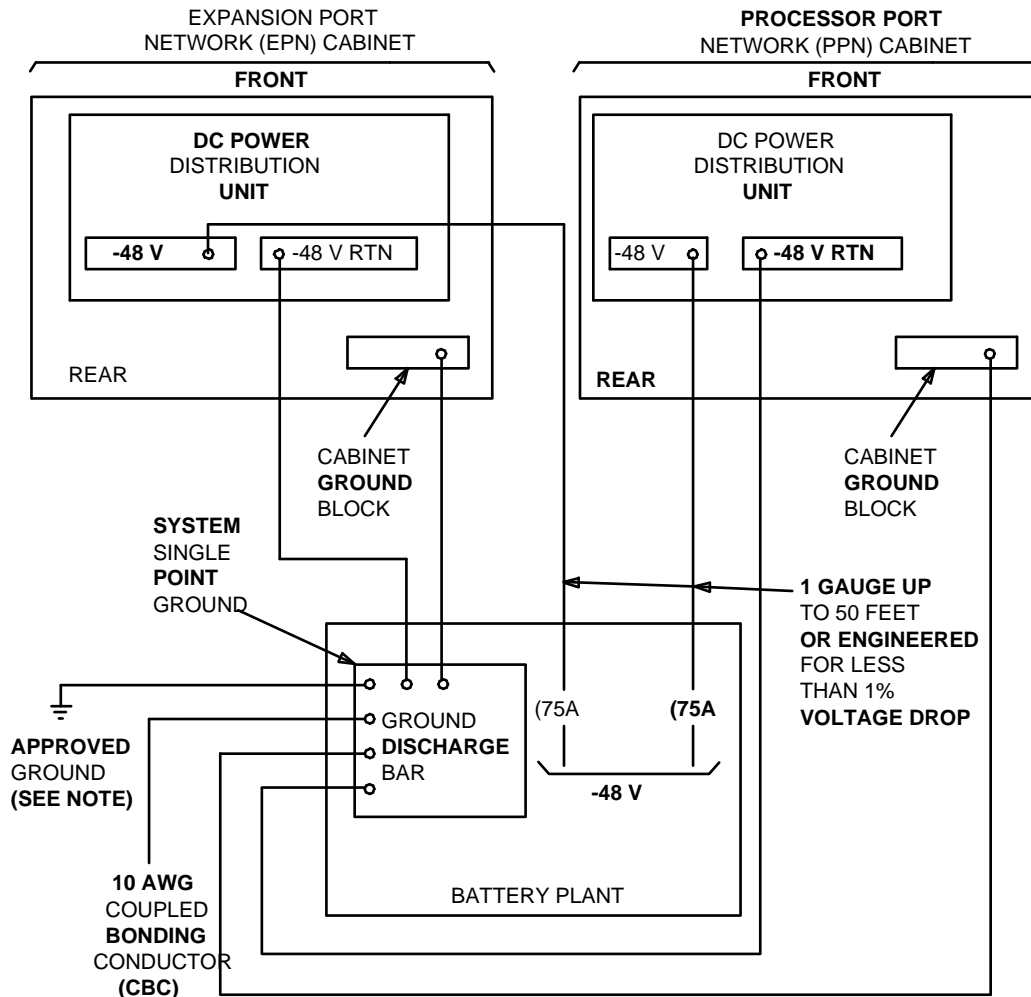

FIGURE 20. Typical Single-Carrier AC Power and Grounding Layout (Remotely Located EPN)

## DC Power Requirements

### Multi-Carrier Cabinet System

A DC power plant may be used to power the multi-carrier system cabinets. Figure 21 shows a typical power and grounding layout for a DC-powered multi-carrier cabinet.



NOTE:  
 USE APPROVED GROUND LOCATED NEAREST THE TELEPHONE  
 COMPANY OWNED PROTECTOR GROUND BLOCK AT THE  
 BUILDING ENTRANCE FACILITY

FIGURE 21. Typical Multi-Carrier Cabinet System DC Power and Grounding Layout (EPN Colocated)

Table Q provides the requirements for input DC power.

**TABLE Q. -48 Volt DC Input Power Requirements**

<b>Parameter</b>	<b>Requirements</b>
Static Voltage	-48 V DC nominal, -42.5 V DC minimum, -52.5 V DC maximum (measured at input to system cabinet)
Dynamic Voltage	Transient change in voltage (+/- 5% of steady state voltage) Allowed transient duration (up to 200 milliseconds)
AC Ripple Voltage	Maximum wideband AC ripple (450 mvpp in the 3 kHz-to-20 MHz band)
Low Voltage Disconnect	Automatic disconnect occurs when input voltage becomes less than -42.5 V DC (control provided with battery plant).
Overvoltage Protection	Input voltage shall not exceed -52.5 V DC.
Voltage Drop	Maximum drop must not exceed 0.5 V DC one-way on feeder cable between the power board and the system cabinet. Feeders must be UL approved and CSA certified. Feeder gauge must be no smaller than 6 AWG and no larger than 1/0 gauge.  Recommended -48 V DC feeder cable— <b>Royal Electric #4905 or equivalent</b> 1-AWG is required for distances up to 50 feet. Cable resistance must be equal to or less than 0.1290 ohms per 1000 feet.
Current Draw	The battery plant rectifiers must be capable of providing current for the system, including current required for system holdover and for charging the batteries. In addition, this may include DC current required for an inverter that provides AC power to peripheral equipment, if it is installed, and for future growth.
Circuit Breaker	A UL-listed and CSA-certified circuit breaker must be provided at the battery plant power board for each system cabinet feeder.  The recommended circuit breakers are <b>75 ampere Airpax UPLI-1-REC2-52-753 or Heinemann AM1-B2-A-75-2.</b>

**TABLE Q (continued).  
-48 Volt DC Input Power Requirements**

Parameter	Requirements
Redundancy	Redundancy of the battery chargers/rectifiers should be considered. This would also provide the additional current necessary to recharge the batteries after being fully discharged.
Electrical Noise	Voice band noise from the battery plant to the system must be less than 32dBmC.
Grounding	<p>A single point ground must be maintained.</p> <p>A ground conductor must be installed from the isolated Ground Discharge Bar* to the closest Approved Ground via the shortest route as required by the NEC/REC. The gauge must be no smaller than the largest conductor in the system and larger than 6 AWG.</p> <p>The Ground Discharge Bar shall not be connected electrically to the chassis of the battery plant chargers, power board, or inverter(s).</p> <p>All output power shall be isolated from the input power.</p>
Lightning Protection	There must be adequate lightning protection in the battery plant to ensure that the system will not be damaged.

As shown in Figure 21, the size of the wire required for the -48 V DC and -48 V return must be engineered so that ***the -48 V DC supplied by the battery plant to the G1 cabinets will be maintained between -42.5 and -52.5 V DC at all times*** to ensure proper operation and to prevent hardware damage.

\* Refer to *DEFINITY® Communications System Generic 1 and Generic 3—Installation and Test*, 555-230-104, for parts and location information.



Figures 17 and 18 provide a power and grounding layout for mixed AC-/DC-powered multi-carrier cabinet configurations.

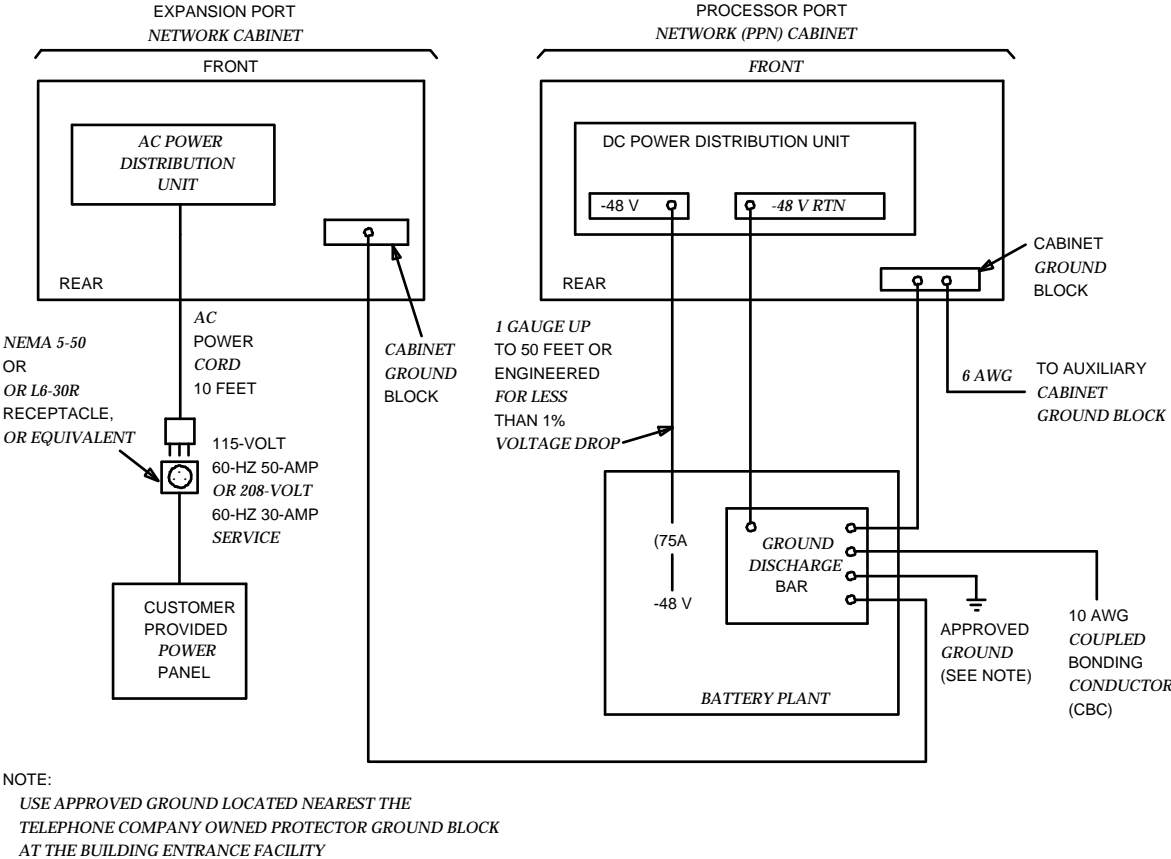
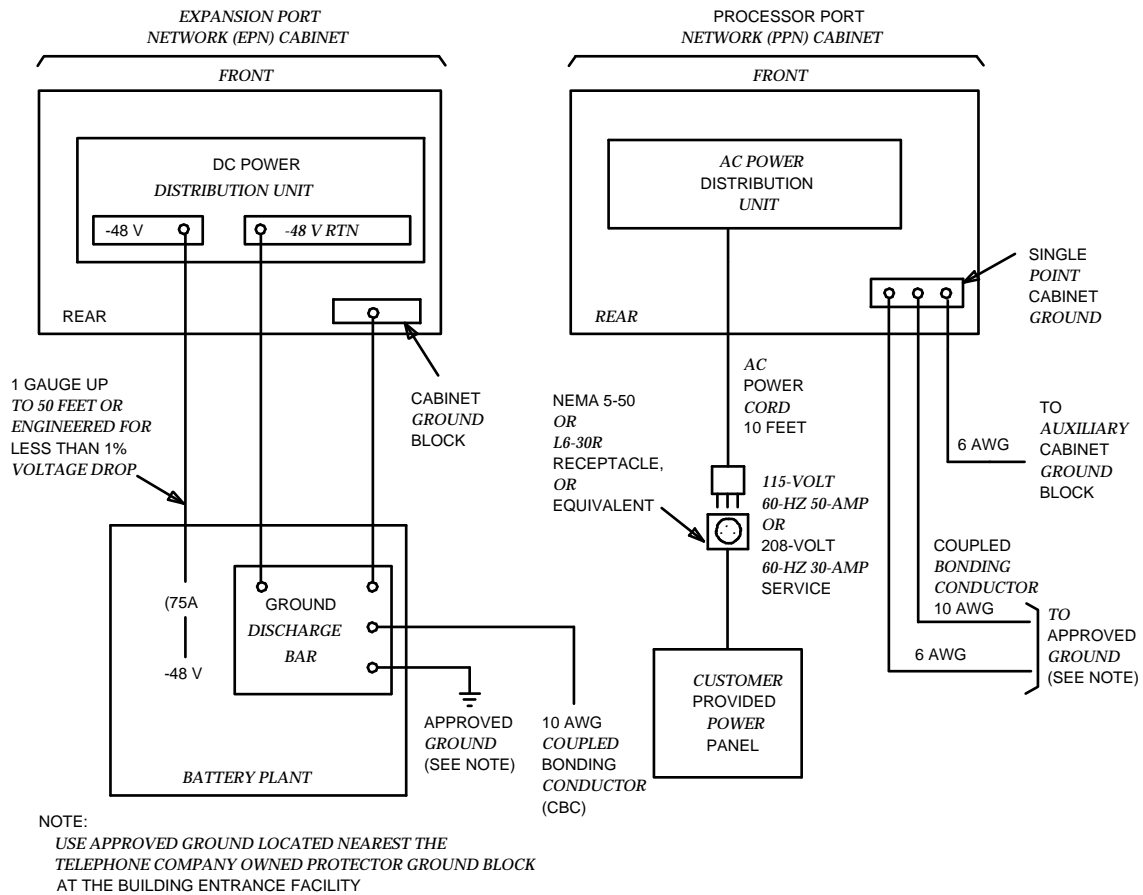

FIGURE 22. Typical Multi-Carrier Mixed AC/DC Power and Grounding Layout (EPN Colocated)



**FIGURE 23. Typical Multi-Carrier Mixed AC/DC Power and Grounding Layout (Remotely Located EPN)**

For DC-powered systems, a ground wire must be installed from the isolated Ground Discharge Bar on the battery plant to the Approved Ground. (See “Grounding.”) The size of the wire must be no smaller than the largest wire in the system and **must be** larger than 6 AWG. The approved ground connection must be identified with a Form 15657NR or equivalent grounding tag. The Ground Discharge Bar shall not be connected electrically to the chassis of the chargers, power board, or inverters. All output power must be isolated from the input power.

A 6-AWG ground wire must be connected to the ground block in the bottom of each cabinet (Figure 21). The ground wire is routed out of the cabinet and terminated on the battery plant.

### Single-Carrier Cabinet System

Each cabinet requires a separate DC power input. See Table Q for input DC power requirements. Figure 24 provides a typical DC powered and grounding arrangement for a single-carrier cabinet system.

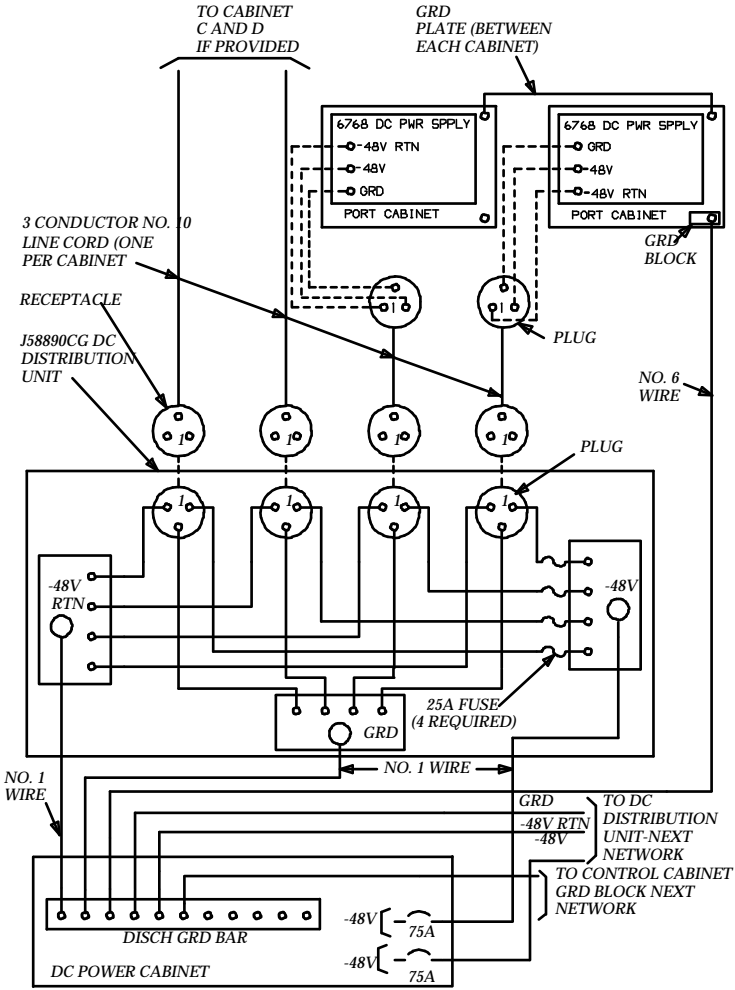

**FIGURE 24. Typical Single-Carrier DC Power and Grounding Layout (EPN Colocated)**

A ground wire is connected to the ground block of the bottom cabinet and routed to the battery plant for termination on the Ground Discharge Bar. An approved ground must be terminated on the Ground Discharge Bar.

## Grounding

An approved ground for the cabinets used in the equipment room is essential. A typical approved ground is one of the following:

- **Grounded Building Steel**—The metal frame of the building where effectively grounded by one of the following grounds: acceptable metallic water pipe, concrete-encased ground, or a ground ring.
- **Acceptable Water Pipe**—A metal underground water pipe, at least 1/2-inch in diameter, in direct contact with the earth for at least 10 feet. The pipe must be electrically continuous (or made electrically continuous by bonding around insulated joints, plastic pipe, or plastic meters) to the point where the protector ground wire is connected. A metallic underground water pipe must be supplemented by the metal frame of the building, a concrete-encased ground, or a ground ring. If these grounds are not available, the water pipe ground can be supplemented by one of the following types of ground:
  - Metal underground gas piping system—An electrically continuous metal underground gas piping system that is uninterrupted with insulating sections or joints and without an outer nonconductive coating
  - Other local metal underground systems or structures—local underground structures such as tanks and piping systems
  - Rod and pipe electrodes—A 5/8-inch (solid rod) or 3/4-inch (conduit or pipe) electrode driven to a minimum depth of 8 feet
  - Plate electrodes—Expose a minimum of 2 square feet of metallic surface to the exterior soil
- **Concrete-Encased Ground**—An electrode encased by at least 2 inches of concrete and located within and near the bottom of a concrete foundation or footing in direct contact with the earth. The electrode must be at least 20 feet of one or more steel reinforcing bars or rods, not less than 1/2 inch in diameter, or at least 20 feet of bare, solid copper wire not smaller than 4 AWG.
- **Ground Ring**—A buried ground that encircles a building or structure at a depth of at least 2-1/2 feet below the earth's surface. The ring must consist of at least 20 feet of bare copper conductor not smaller than 2 AWG.

All approved grounds used must be bonded together to form a single grounding electrode system as required in Section 250-81 of the National Electrical Code.

Approved floor grounds are those grounds on a floor of a high-rise building suitable for connection to the ground terminal in the riser closet and to the PBX equipment single point ground terminal. Such grounds may be one of the following:

- Building steel
- The grounding conductor for the secondary side of the power transformer feeding the floor
- Metallic water pipes
- Power feed metallic conduit supplying panel boards on the floor
- A grounding point specifically provided in the building for the purpose

## **Lightning Protection**

A coupled bonding conductor is tie-wrapped to all trunks. The coupled bonding conductor can be any one of the following:

- 10-AWG ground wire
- Continuous cable sheath
- Six unused pairs of wire

The coupled bonding conductor connects the cabinet single-point ground block and runs all the way to the approved ground located nearest the telephone company-owned protector block at the building entrance facility.

When an auxiliary cabinet is provided with a multi-carrier cabinet system, a 6-AWG ground wire connects the system cabinet single-point ground block to the auxiliary cabinet ground block. It is recommended that the ground wire be routed as close as possible to the cables connecting the system cabinet and the auxiliary cabinet.

If auxiliary equipment is not mounted in the auxiliary cabinet, then the power supply for this equipment must be plugged into one of the two convenience outlets located on the back of the multi-carrier cabinet to preserve ground integrity. The convenience outlet is fused at 5 amps. The dedicated Manager I or G3r-MT terminal should be plugged into the other convenience outlet.

## **Sneak Current Protection**

Sneak fuses protect the building wiring and circuit packs from “foreign potential” by providing a current interruption capability. Sneak fuse panels, when provided, are installed on the switch side of the network interface. All incoming and outgoing trunks and off-premises station lines pass through the sneak fuses. Sneak current protection is required for installations in Canada. The sneak fuses must be CSA certified.

## Standby Power System—Multi-Carrier Cabinet System

### Battery Reserve (Multi-Carrier System)

The system provides a 10-second power holdover during power interruptions. A battery reserve supplies power to a single control carrier for up to 10 minutes during a commercial power failure. With duplicated control carriers, power is available for 5 minutes. If additional holdover power is required, an alternate, independent source of on-premises power is required to maintain the system for a limited time. An external, commercial Uninterruptible Power Supply (UPS) or a battery backup arrangement are used as an alternate source of power during a commercial power failure.

### Uninterruptible Power Supply (Multi-Carrier System)

The uninterruptible power supply (UPS) protects the system equipment from voltage lags, over-voltage conditions, blackouts, and line frequency fluctuations. The UPS uses a microprocessor controlled device to regulate and condition the commercial power. During commercial power failure, UPS provides dependable and reliable backup power for short durations.

**Note:** Any peripheral that is connected to the system and derives its power from a wall socket will not be supported during a power outage. This also applies to the 7407D and 7404D voice terminals.

For most multi-carrier cabinet system configurations, any UPS that meets the requirements given in Table R or Table S can be used with the system for standby power.

**TABLE R. AC Power Requirements**

No. of Control Carrier	No. of Port Carrier	Power Rating (KVA)	Frequency Hertz	Power Factor
1	0	0.90	60 ± 5%	0.70
1	1	1.50	60 ± 5%	0.70
1	2	2.10	60 ± 5%	0.70
1	3	2.70	60 ± 5%	0.70
1	4	3.30	60 ± 5%	0.70

TABLE S. DC Power Requirements

No. of Control Carrier	No. of Port Carrier	Input Power (Watts)
1	0	630
1	1	1050
1	2	1470
1	3	1890
1	4	2310

**Battery Backup (Multi-Carrier System)**

A battery supply and an inverter can be used to provide standby power for up to 8 hours after a commercial power failure.

When standby power is provided, the following items must be taken into consideration:

- Size and weight of the batteries
- Size and weight of the inverter(s)
- Heat dissipation
- Air flow and circulation
- Items of equipment to receive power

This standby power system contains the following:

- Inverter
- Batteries
- Battery stand

The system requires a 120-volt AC input that is provided by the inverter. The size of the inverter is determined by the carrier configuration and the additional equipment to be provided with power in the event of a commercial power failure. The size of the battery supply required depends upon the length of time power is to be provided and the particular power demands of the system. Tables R and S show the approximate power consumption requirements that can be used to size the system for emergency generators or battery backup.

## Standby Power—Single-Carrier Cabinet System

The following provides Battery Reserve, Uninterruptible Power Supply, and Battery Backup information for single-cabinet systems.

### Battery Reserve (Single-Carrier System)

During commercial power failure, the power supply provides a 250-millisecond power holdover to allow the system to remain in service. If power is restored within 250 milliseconds, there is no interruption of service.

A battery reserve is automatically activated if commercial AC power fails. These batteries allow the power supply to provide a 2-minute battery reserve holdover to the control circuit packs and fans during power failure beyond 250 milliseconds. All port circuit packs are out of service during this time. When commercial power is restored within 2 minutes, the system reinitializes from the memory stored in the Memory circuit pack. All port circuit packs continue to remain out of service during the approximately 25 seconds required to restore the system.

When commercial power is restored after 2 minutes, the system reinitializes from the system tape. Reinitialization takes approximately 10 minutes and the port circuit packs remain out of service during this time.

The Emergency Transfer feature becomes active if commercial power failure exceeds 250 milliseconds. Selected voice terminals are automatically connected to trunks in the central office.

If additional holdover power is required, an alternate, independent source of on-premises power is required to maintain the system for a limited time. An external, commercial Uninterruptible Power Supply (UPS) or a battery backup arrangement are used as an alternate source of power during a commercial power failure.

### Uninterruptible Power Supply (Single-Carrier System)

If long-term holdover power is required, an external Uninterruptible Power Supply (UPS) can be provided as an alternate source of power during a commercial power failure. Any UPS that meets the requirements given in Table T can be used with the system.

**TABLE T. UPS Power Requirements**

No. of Cabinets	Volt-Ampere Rating	Frequency Hertz	Power Factor	Maximum Cut-In Time (milliseconds)
1	1200	60 ± 5%	0.6	200
2	2400	60 ± 5%	0.6	200
3	3600	60 ± 5%	0.6	200
4	4800	60 ± 5%	0.6	200



### **Battery Backup (Single-Carrier System)**

A battery supply and an inverter can be used to provide standby power for up to 8 hours after a commercial power failure.

When standby power is provided, the following items must be taken into consideration:

- Size and weight of the batteries
- Size and weight of the inverter(s)
- Heat dissipation
- Air flow and circulation
- Items of equipment to receive power

This standby power system contains the following:

- Inverter
- Batteries
- Battery stand

The single-carrier cabinet system requires a 120-volt AC input that is provided by the inverter. The size of the inverter is determined by the system configuration and the additional equipment to be provided with power in the event of a commercial power failure. The size of the battery supply required depends upon the length of time power is to be provided and the particular power demands of the system. Table T shows the approximate power consumption requirements that can be used to size the system for emergency generators or battery backup.

## **House Wiring**

House wiring includes all on-premises wiring on the customer side of the cross-connect field. The cross-connect field can be either 66-type or 110-type hardware.

Wiring is distributed from the cross-connect field by 25-pair cables. The 25-pair cables are connected either directly to terminal wall jacks using adapters or to satellite locations. Satellite locations are used when already present or when required by the length of the wiring runs from the switch to the terminals. The 25-pair cables can be divided into either 4-pair or 3-pair wiring groups (4-pair wiring groups are recommended). From the satellite locations, 4-pair D-inside cables connect the satellite locations to information outlets (modular wall jacks).

See *DEFINITY® Communications System Generic 1 and Generic 3i—Wiring*, 555-204-111, for details on the cross-connect hardware and wiring distribution.

## UPGRADES AND ADDITIONS

The upgrade process consists of changing the hardware and software of the a previously installed system to that of a later version system. An upgrade may be performed in response to increased call processing demands, need for greater feature capabilities, or other changes in customer requirements.

The addition process consists of adding voice terminals, circuit packs, carriers, or software features to an existing system without upgrading the version of the system.

The following provides a synopsis of the upgrades and additions process for DEFINITY Communications System Generic 1 and Generic 3.

For specific details on the upgrade process and associated administration, refer to the *DEFINITY® Communications System Generic 1 and Generic 3i—Upgrades and Additions*, 555-204-106, or *DEFINITY® Communications System Generic 3r—Upgrades and Additions*, 555-230-106.

### **System 75 Upgrade to DEFINITY Generic 1 PPN Without Duplication**

The System 75 Versions 1 (V1), 2 (V2), or 3 (V3) upgrade to DEFINITY Generic 1 requires the following:

- Replacing the J58890AA-1/J58890AB-1 Control Carrier with a J58890AH-1 Control Carrier
- Replacing TN711 Processor circuit pack with a TN773 Processor circuit pack
- Replacing TN734 Memory circuit packs with a TN770 Memory circuit pack
- Replacing TN727 Network Control circuit pack with a TN777 Network Control circuit pack
- Replacing TN741 Tone Clock circuit pack with a TN768 Tone Clock circuit pack
- Replacing the TDM cables with new WP91716 L1 and L2 TDM/LAN cables
- Adding a new TN774 tape drive circuit pack and removing the HCMR/RMSS tape drive
- Adding a TN765 Processor Interface circuit pack if required
- Replacing the software tape
- Activating and administering new features

If an Expansion Port Network (EPN) is required, an EPN cabinet is added. A TN776 Expansion Interface circuit pack is added to the Processor Port Network (PPN) cabinet. A fiber link connects the Expansion Interface circuit packs.

## System 75 Upgrade to DEFINITY Generic 1 PPN With Duplication

The System 75 Versions 1 (V1), 2 (V2), or 3 (V3) upgrade to DEFINITY Generic 1 with duplication requires the following:

- Replacing the J58890AA-1/J58890AB-1 Control Carrier with a J58890AH-1 Control Carrier
- Replacing TN711 Processor circuit pack with a TN773 Processor circuit pack
- Replacing TN734 Memory circuit packs with a TN770 Memory circuit pack
- Replacing TN727 Network Control circuit pack with a TN777 Network Control circuit pack
- Replacing TN741 Tone Clock circuit pack with a TN768 Tone Clock circuit pack
- Replacing the TDM cables with new WP91716 L1 and L2 TDM/LAN cables
- Adding a new TN774 tape drive circuit pack and removing the HCMR/RMSS tape drive
- Adding a TN765 Processor Interface circuit pack if required
- Replacing the J58890BB-3 Port Carrier in position B with a J58890AJ-1 Duplicated Control Carrier that contains the following circuit packs.
  - Processor circuit pack TN773
  - Memory circuit pack TN770
  - Tape Drive circuit pack TN774
  - Network Control circuit pack TN777
  - Duplication Interface circuit pack TN772
  - Tone Clock circuit pack TN768 in both J58890AJ-1 and J58890AH-1
- Adding a TN772 Duplication Interface circuit pack to the J58890AH-1 Control Carrier
- Adding the inter-carrier cable between the J58890AH-1 Control Carrier and the J58890AJ-1 Duplicated Control Carrier
- Adding the new software tape to the tape drive in both the J58890AH-1 Control Carrier and the J58890AJ-1 Duplicated Control Carrier
- Activating and administering new features

If an EPN is required, an EPN cabinet is added. Two TN776 Expansion Interface circuit packs are needed in the PPN cabinet. Two fiber links are required to connect the Expansion Interface circuit packs.

## **System 75 Upgrade to DEFINITY Generic 1 EPN Without Duplication**

The System 75 Medium Cabinet is upgraded to the EPN Cabinet Without Duplication by:

- Removing the tape drive unit
- Removing the J58890AA-1/J58890AB-1 Control Carrier
- Installing the J58890AF-1 expansion Control Carrier
- Replacing TN741 Tone Clock circuit pack with a TN768 Tone Clock circuit pack
- Adding TN775 Maintenance circuit pack
- Replacing the TDM cables with new WP91716 L1 and L2 TDM/LAN cables
- Adding and restructuring the port circuit packs as required

A TN776 Expansion Interface circuit pack is added to the PPN cabinet. A fiber link connects the Expansion Interface circuit packs.

## **System 75 Upgrade to DEFINITY Generic 1 EPN With Duplication**

The System 75 Medium Cabinet is upgraded to the EPN Cabinet With Duplication by:

- Removing the tape drive unit
- Removing the J58890AA-1/J58890AB-1 Control Carrier
- Installing the J58890AF-1 expansion Control Carrier
- Replacing TN741 Tone Clock circuit pack with two TN768 Tone Clock circuit packs (one in the first and one in the second carrier)
- Adding TN775 Maintenance circuit pack
- Replacing the TDM cables with new WP91716 L1 and L2 TDM/LAN cables
- Adding and restructuring the port circuit packs as required
- Adding two TN776 Expansion Interface circuit packs (one in the first port carrier in the EPN Cabinet and one in the second)

Two TN776 Expansion Interface circuit packs are needed in the PPN Cabinet as well. Two fiber links are required to connect the Expansion Interface circuit packs.

## System 75 XE Upgrade To DEFINITY Generic 1 PPN Without Duplication

The System 75 XE Versions 2 (V2) or 3 (V3) upgrade to DEFINITY Generic 1 requires the following:

- Replacing the J58890G-1 Control Cabinet with a J58890L-1 Basic Control Cabinet containing the following
  - Tape Drive circuit pack TN774
  - Processor TN773
  - Memory TN770
  - Network Control TN777
- Replacing the TDM cables with WP91716 L3 TDM cables if required
- Adding a TN765 Processor Interface circuit pack if required
- Replacing the TN756 Tone Detector/Generator circuit pack with a TN768 circuit pack and a TN748 Tone Detector circuit pack when DS1, ISDN, or EPN applications are required
- Installing the old port circuit pack in the new J58890L-1 cabinet
- Replacing the software tape
- Activating and administering new features

If an EPN is required, an Expansion Control Cabinet is added. The TN776 Expansion Interface circuit pack is added to the Basic Control Cabinet. A fiber cable connects the Expansion Interface circuit packs.

## System 75 XE Upgrade to DEFINITY Generic 1 PPN With Duplication

The System 75 XE Versions 2 (V2) or 3 (V3) upgrade to DEFINITY Generic 1 with duplication requires the following:

- Replacing the J58890G-1 Control Cabinet with a J58890L-1 Basic Control Cabinet containing the following:
  - Tape Drive circuit pack TN774
  - Processor circuit pack TN773
  - Memory circuit pack TN770
  - Network Control circuit pack TN777
- Replacing the TDM cables with WP91716 L3 TDM cables if required
- Replacing the TN756 Tone Detector/Generator circuit pack with TN768 Tone Clock circuit pack and a TN748 Tone Detector circuit pack
- Adding a TN765 Processor Interface circuit pack if required
- Adding the J58890M-1 Duplicated Control Cabinet in cabinet position B. This cabinet contains the following circuit packs.
  - Processor circuit pack TN773
  - Memory circuit pack TN770
  - Tape Drive circuit pack TN774
  - Network Control circuit pack TN777
  - Duplication Interface circuit pack TN772
  - Tone Clock circuit pack TN768 in both the J58890L-1 and J58890M-1 cabinets
- Adding the inter-cabinet cable between the J58890L-1 Control Cabinet and the J58890M-1 Duplicated Control Cabinet
- Adding the old port circuit packs in the new J58890L-1 Control Cabinet and J58890M-1 Duplicated Control Cabinet
- Adding the new software tape to the tape drive in both the J58890L-1 Control Cabinet and the J58890M-1 Duplicated Control Cabinet
- Activating and administering new features

If an EPN is required, an Expansion Control Cabinet and a Port Cabinet are added. A TN776 Expansion Interface circuit pack is needed in the Control Cabinet J58890L-1 and the Duplicated Control Cabinet J58890M-1. Two fiber cables connect the Expansion Interface circuit packs.

## **System 75 XE Upgrade to DEFINITY Generic 1 EPN Without Duplication**

The System 75 XE is upgraded to the EPN Cabinet Without Duplication as follows:

- Replace the Control Cabinet J58890G-1 with an Expansion Control Cabinet J58890N-1
- Replace the TDM cables with WP91716 L3 TDM cables if required
- Add and restructure port circuit packs

## **System 75 XE Upgrade to DEFINITY Generic 1 EPN With Duplication**

The System 75 Single-Carrier Cabinet is upgraded to the EPN cabinet With Duplication as follows:

- Replace the Control Cabinet J58890G-1 with an Expansion Control Cabinet J58890N-1
- Replace the TDM cables with WP91716 L3 TDM cables if required
- Add and restructure port circuit packs
- Add an Expansion Interface circuit pack to the first and second port cabinets
- Add two TN768 Tone Clock circuit packs (one in the first cabinet and one in the second cabinet)

Two TN776 Expansion Interface circuit packs are needed in the PPN cabinet. Two fiber links are required to connect the Expansion Interface circuit packs.

### **Circuit Pack Additions and Replacements**

The following circuit packs, although not required for the basic upgrade, may need to be added or replaced for additional features:

- TN722—Provides connection capability to DS1, alternate/voice data (AVD), and Digital Multiplexed Interface (DMI) facilities.
- TN767 DS1 Interface—Provides connection capability to ISDN feature in addition to the features supported by the TN722.
- TN725 Speech Synthesizer—Provides speech synthesis application for Leave Word Calling feature and supports the Automatic Wakeup feature.
- TN726 Data Line—Provides direct connection capability to asynchronous equipment with EIA-232C interfaces.
- TN760 Tie Trunk—Provides the release-link trunks required for Centralized Attendant Service (CAS). The release-link trunks can also be provided by the DS1 Tie Trunk circuit pack.
- TN746 Analog Line (16 ports)—Used to provide a 16 ports per circuit pack for on-premises (in building) analog terminals.
- TN750 Announcement—Provides an integrated means for recording announcements that can then be played back on demand from call processing as part of a calling feature. Messages can be recorded by customers from their voice terminals, on- or off-premises, and have flexible message lengths. Up to 16 different messages can be played back simultaneously. The TN750 cannot be used for the Automatic Wakeup feature.
- TN755 Power Unit—Converts -48 volt DC to neon lamp voltage required by the circuit packs.
- TN747 CO Trunk—Supports the Abandoned Call Search feature for ACD applications.
- TN763 Auxiliary Trunk—Supports Audichron announcement equipment.

### **Attendant Console Replacement**

To support the Emergency Access to the Attendant feature, the attendant console must be a 301A1-A, 302A1-A, or 301B1-A.



## Port Circuit Pack Upgrades for DEFINITY Generic 3r

It may be necessary, depending on the features required for a particular upgrade, to upgrade some of the port circuit packs. Table U lists the port circuit packs that may need to be upgraded to a later vintage of the same circuit pack or to a different circuit pack, along with the circumstances that make the upgrade necessary.

**TABLE U. Port Circuit Pack Upgrades**

Type	Code	Upgrade Reason
Service	TN725 Speech Synthesizer	Replace with latest model of TN725 (for example, TN725B) for full functionality.
	TN748 or TN748B Tone Detector	Replace with latest model of TN748 (for example, TN748C) if the Outbound Call Management (OCM) feature is required for the system.
	TN714 Tone Clock	Replace all TN714 models with TN768 Tone Clock for full functionality. If Stratum 3 interface is required in the PPN, replace with TN780 Tone Clock.
	TN741 Tone Clock	Replace all TN741 models with TN768 Tone Clock for full functionality. If Stratum 3 interface is required in the PPN, replace with TN780 Tone Clock.
	TN756 Tone Clock	Replace all TN756 models with TN768 Tone Clock for full functionality. If Stratum 3 interface is required in the PPN, replace with TN780 Tone Clock.
	TN776 Expansion Interface	Replace all TN776 models with TN570 Expansion Interface for connection to Switch Node Interface.
	TN775 EPN Maintenance	Replace with latest model for full functionality.
Line	TN762 Hybrid Line	Replace TN762 with TN762B or later model for 7300 sets and if dropping incoming calls.
Trunk	TN747 Central Office Trunk	Replace TN747 with TN747B or later model if ACD is required for the system.
	TN760 Tie Trunk	Replace TN760 with TN760B vintage 6 (or later model) if CAS is required for the system and if there is an end-to-end signaling problem.
	TN763 Auxiliary Trunk	Replace TN763 with latest model if Audichron Announcement Equipment is included in the system.
	TN722 DS1 Tie Trunk	Replace TN722 with TN722B vintage 6 (or later model) if CAS is required for the system.
	TN767 DS1 Interface	Replace with the latest model of TN464 32-Channel E1 Trunk if ISDN-PRI and the DS0 channel are required for the system. TN767 can be reused if only DS1 or NFS in-line service are required.

## **DEFINITY Generic 1 Upgrade to DEFINITY Generic 3r PPN**

When upgrading an existing system to a DEFINITY G3r PPN, with or without duplication, only new shipments of PPNs are supported, so existing cabinets cannot be upgraded regardless of type. Please note that the PPN of a G3r system is only housed in a multi-carrier cabinet.

## **DEFINITY Generic 1 PPN Upgrade to DEFINITY Generic 3r EPN MCC Without Duplication**

The DEFINITY Generic 1 PPN multi-carrier cabinet upgrade to DEFINITY Generic 3r EPN MCC requires the following:

- Remove all port circuit packs in the cabinet position A Control Carrier J58890AH. These will be reused in the carrier replacement.
- Remove TN776 Expansion Interface circuit pack (located in port slot 1).
- Remove all other control circuit packs. These will not be reused except for TN768 Tone Clock.
- Remove power units (631DA and 631DB for AC systems and 644A and 645B for DC systems). These will be reused. Also, power units 631AR and 631BR or 631WA and 631WB (AC systems) will work in the G3r, if present. However, if you do reuse the 631AR and 631BR or 631WA and 631WB power supplies, it is required that you reuse either the TN736 or TN752 Power Converter circuit pack with them.
- Remove inter-carrier cables. Only TDM/LAM bus cables (WP-91716) or terminator (ZAHF4) will be reused.
- Replace J58890AH in cabinet position A with Expansion Control Carrier J58890AF in the cabinet position A. The same cabinet interface cables (wiring harnesses) are reused.
- Install two power units (631DA and 631DB for AC systems and 644A and 645B for DC systems). You can also install power units 631AR and 631BR or 631WA and 631WB as an alternative. However, if you do reuse the 631AR and 631BR or 631WA and 631WB power supplies, it is required that you reuse either the TN736 or TN752 Power Converter circuit pack with them.
- Install TN775 Maintenance circuit pack.
- Install TN570 Expansion Interface circuit pack in port slot 1.
- Install TN768 Tone Clock circuit pack from the DEFINITY Generic 3i.
- Port circuit packs that were removed can be reinstalled in the Expansion Control Carrier. Port circuit packs that must be upgraded for G3r functionality can be installed at this time. See Table U for a list of the circuit packs and their replacements.

- One current limiter (CFY1) circuit pack is installed on the Expansion Control Carrier in cabinet position A.
- Reapply the TDM/LAN bus cables or terminator.
- The AUX connection previously made to the A position Control Carrier can also be reused to the new A position Expansion Control Carrier. Note, however, that the AUX connection will no longer support the Initialization and Administration System (INADS) link. The terminal connections used previously can also be reused to the new A position Expansion Control Carrier.

### **DEFINITY Generic 1 EPN MCC Upgrade to DEFINITY Generic 3r EPN MCC With Duplication**

The DEFINITY Generic 1 EPN MCC upgrade to DEFINITY Generic 3r EPN MCC requires the following:

- Remove TN776 Expansion Interface circuit pack (located in port slot 1 of cabinet position A Expansion Control Carrier J58890AF). This will not be reused.
- Remove TN776 Expansion Interface circuit pack (located in port slot 2 of cabinet position B Port Carrier J58890BB). This will not be reused.
- Install TN570 Expansion Interface circuit pack in port slot 1 of cabinet position A Expansion Control Carrier J58890AF.
- Install TN570 Expansion Interface circuit pack in port slot 2 of cabinet position B Port Carrier J58890BB.
- Port circuit packs that must be upgraded for G3r functionality can be installed at this time. See Table U for a list of the circuit packs and their replacements.

## **DEFINITY Generic 1 EPN SCC Upgrade to DEFINITY Generic 3r EPN SCC Without Duplication**

The DEFINITY Generic 1 EPN SCC upgrade to DEFINITY Generic 3r EPN SCC requires the following:

- Remove TN776 Expansion Interface circuit pack (located in port slot 1 of cabinet position A Expansion Control Cabinet J58890N). This will not be reused.
- Install TN570 Expansion Interface circuit pack in port slot 1 of cabinet position A Expansion Control Cabinet J58890N.
- Port circuit packs that must be upgraded for G3r functionality can be installed at this time. See Table U for a list of the circuit packs and their replacements.

## **DEFINITY Generic 1 PPN SCC Upgrade to DEFINITY Generic 3r EPN SCC Without Duplication**

The DEFINITY Generic 1 PPN SCC upgrade to DEFINITY Generic 3r EPN SCC requires the following:

- Remove all port circuit packs in the cabinet position A Control Carrier J58890L. These will be reused in the carrier replacement.
- Remove TN776 Expansion Interface circuit pack (located in port slot 1).
- Remove all other control circuit packs. These will not be reused except for TN768 Tone Clock. A Control Cabinet supporting a single port network will have a TN756 Tone Generator Clock instead of the TN768 Tone Clock. The TN756 Tone Generator clock cannot be used in the upgrade, and must be replaced with the TN768 Tone Clock.
- Remove power unit (WP91153 for AC systems and 676B for DC systems). This will be reused.
- Remove inter-carrier cables. Only TDM/LAM bus cables (WP-91716, L3) and terminator (AHF110) will be reused.
- Replace Control Cabinet J58890L in cabinet position A with Expansion Control Cabinet J58890N in the cabinet position A.
- Reapply the TDM/LAN bus cables and terminator.
- Install power unit (WP91153 for AC systems and 676B for DC systems).
- Install TN775 Maintenance circuit pack.
- Install TN570 Expansion Interface circuit pack in port slot 1.
- Install TN768 Tone Clock circuit pack.

- Port circuit packs that were removed can be reinstalled in the Expansion Control Cabinet. Port circuit packs that must be upgraded for G3r functionality can be installed at this time. See Table U for a list of the circuit packs and their replacements.
- One current limiter (CFY1) circuit pack is installed on the Expansion Control Cabinet in cabinet position A.
- The AUX connection previously made to the A position Control Cabinet can also be reused to the new A position Expansion Control Cabinet. Note, however, that the AUX connection will no longer support the INADS link. The terminal connections used previously can also be reused to the new A position Expansion Control Cabinet.

### **DEFINITY Generic 1 EPN SCC Upgrade to DEFINITY Generic 3r EPN SCC With Duplication**

The DEFINITY Generic 1 EPN SCC upgrade to DEFINITY Generic 3r EPN SCC requires the following:

- Remove TN776 Expansion Interface circuit pack (located in port slot 1 of cabinet position A of the Expansion Control Cabinet J58890N). This will not be reused.
- Remove TN776 Expansion Interface circuit pack (located in port slot 2 of cabinet position B of the Port Carrier Cabinet J58890H). This will not be reused.
- Install TN570 Expansion Interface circuit pack in port slot 1 of cabinet position A of the Expansion Control Cabinet J58890N.
- Install TN570 Expansion Interface circuit pack in port slot 2 of cabinet position B of the Expansion Control Cabinet J58890H.
- Port circuit packs that must be upgraded for G3r functionality can be installed at this time. See Table U for a list of the circuit packs and their replacements.

## **DEFINITY Generic 1 PPN SCC Upgrade to DEFINITY Generic 3r EPN SCC With Duplication**

The DEFINITY Generic 1 PPN SCC upgrade to DEFINITY Generic 3r EPN SCC requires the following:

- Remove all port circuit packs in the cabinet position A Control Cabinet J58890L. These will be reused in the carrier replacement.
- Remove all port circuit packs in the cabinet position B Control Cabinet J58890M. These will be reused in the carrier replacement.
- Remove TN776 Expansion Interface circuit pack (located in port slot 1 of cabinet position A of the Control Cabinet J58890L). This circuit pack will not be reused.
- Remove TN776 Expansion Interface circuit pack (located in port slot 1 of cabinet position B of the Control Cabinet J58890M). This circuit pack will not be reused.
- Remove all other control circuit packs from the cabinet position A Control Cabinet J58890L. These will not be reused except for the TN768 Tone Clock.
- Remove all other control circuit packs from the cabinet position B Control Cabinet J58890M. These will not be reused except for the TN768 Tone Clock.
- Remove power unit (WP91153 for AC systems and 676B for DC systems) from the cabinet position A Expansion Control Cabinet J58890L. This will be reused.
- Remove power unit (WP91153 for AC systems and 676B for DC systems) from the cabinet position B Expansion Control Cabinet J58890M. This will be reused.
- Remove inter-carrier cables from both cabinet position A and B. Only TDM/LAM bus cables (WP-91716, L3) and terminators (AHF110) will be reused.
- Replace Control Cabinet J58890L in cabinet position A with Expansion Control Cabinet J58890N in the cabinet position A.
- Replace Control Cabinet J58890M in cabinet position B with Port Cabinet J58890H.
- Reapply the TDM/LAN bus cables and terminator to cabinet position A Expansion Control Cabinet J58890N.
- Reapply the TDM/LAN bus cables and terminator to cabinet position B Port Cabinet J58890H.
- Install power unit (WP91153 for AC systems and 676B for DC systems) in cabinet position A Expansion Control Cabinet J58890N.
- Install power unit (WP91153 for AC systems and 676B for DC systems) in cabinet position B Port Cabinet J58890H.
- Install TN775 Maintenance circuit pack in Expansion Control Cabinet J58890N.
- Install TN570 Expansion Interface circuit pack in port slot 1 of Expansion Control Cabinet J58890N.
- Install TN768 Tone Clock circuit pack in Expansion Control Cabinet J58890N.

- Port circuit packs that were removed from cabinet position A can be reinstalled in the Expansion Control Cabinet. Port circuit packs that must be replaced are listed in Table U for a list of the circuit packs and their replacements.
- Port circuit packs that were removed from cabinet position B can be reinstalled in the Port Cabinet. Port circuit packs that must be upgraded for G3r functionality can be installed at this time. See Table U for a list of the circuit packs and their replacements.
- One current limiter (CFY1) circuit pack is installed on the Expansion Control Cabinet in cabinet position A.
- The AUX connection previously made to the A position Control Cabinet can also be reused to the new A position Expansion Control Cabinet. Note, however, that the AUX connection will no longer support the INADS link. The terminal connections used previously can also be reused to the new A position Expansion Control Cabinet.
- The Port Cabinets must be readministered. The first Port Cabinet is administered in the B position.
- Duplication cables H600-204 and Gx are added between the Expansion Control Cabinet and the cabinet position B Port Cabinet, connecting ICCA and ICCB pin fields.
- Install TN570 Expansion Interface circuit pack in port slot 1 of Expansion Control Cabinet J58890N.
- Install TN768 Tone Clock in port slot 1 of the cabinet position B Port Cabinet. Any circuit pack previously installed in this position must be relocated.

---

## Additions to the System

The following additions can be made to an existing system.

### Voice Terminal Additions

Voice terminals are added to a system if unused port slots are available. The voice terminals must be physically wired to the cross-connect field and the system. The Manager 1 or G3r-MT terminal is used to administer these voice terminals.

### Circuit Pack Additions

Circuit packs are added to provide additional port capacity for voice terminals and features. The universal port slots available with a system allow the installation of port and service circuit packs without a service interruption.

### Carrier Additions

A port carrier increases the port slot capacity. The multi-carrier cabinet houses up to four port carriers. Adding a port carrier interrupts service.

### Cabinet Additions

With a single-carrier cabinet system, cabinet additions provide an increase in port slot capacity. The port cabinets (up to three) are stacked on top of an existing control cabinet. Installing additional cabinets interrupts service.

### Expansion Port Network Addition

An Expansion Port Network (EPN) addition increases the line capacity of the system. With a multi-carrier cabinet system, the EPN cabinet provides additional port carriers. An Expansion Control Cabinet equipped with a power unit, maintenance circuit pack, and a clock serves as the basic EPN cabinet for a single-carrier cabinet system. Additional port cabinets, up to three, can be stacked on the Expansion Control Cabinet. A fiber cable connects the EPN cabinet to the PPN cabinet. With the Duplication, two fiber cables connect the EPN cabinet to the PPN cabinet.

### Software Feature Additions

Software Feature additions allow customers to buy an added software package feature such as Automatic Route Selection (ARS). A special login is required to activate these features that are always resident on the system tape.



---

## REFERENCES

The following is an abbreviated listing of DEFINITY Generic 1 and Generic 3 documents. Included is a brief description of each document in the list. For a complete list of DEFINITY Generic 1 documents, refer to the *DEFINITY® Communications System Generic 1—Documentation Guide*, 555-200-010.

To order copies of any of these documents, refer to the address on the back of this document's title page. In addition to the following documents, user instruction booklets are also available for all voice terminals that are orderable with the system.

**AT&T Telecommunication Electrical Protection** **350-060**

Provides practical, functional information and application detail combined with training material for telecommunication engineers in the electrical protection field.

**Business Communications Systems Publications Catalog** **555-000-010**

Provides a list of publications that support AT&T business communications systems. Also provides a brief description of each publication listed.

**DEFINITY® Communications System Generic 1 and System 75  
and System 85—Terminals and Adjuncts Installation and Test** **555-015-104**

Provides the information necessary to perform the tasks of installing and testing the system's common equipment. Includes a description of the necessary tools and equipment.

**DEFINITY® Communications System Generic 1 and System 75  
and System 85—Terminals and Adjuncts Reference** **555-015-201**

Provides concise physical and functional descriptions of the peripheral equipment that can be used with DEFINITY 75/85 Communications Systems and System 75 and System 85. It is intended as an aid for both AT&T and customer personnel in selecting appropriate components for these systems and in training and management. Much of the information applies to DEFINITY Communications System Generic 1 and Generic 3 peripherals as well.

**DEFINITY® Communications System and System 75  
and System 85—DS1/DMI/ISDN-PRI Reference** **555-025-101**

Provides both a broad and detailed description of the System 75 and System 85 DS1/DMI/ISDN-PRI Interface. Introduces and defines concepts and terminology unique to DS1/DMI/ISDN-PRI. Also includes applications, engineering procedures and considerations, cabling and connection arrangements, administration requirements, restrictions and limitations, etc.

**DEFINITY® Communications System  
Generic 1 and Generic 3—Feature Description** **555-230-201**

Provides a technical description of system features and parameters.

**DEFINITY® Communications System Generic 1—Console Operation** **555-200-700**

Provides “how-to-operate” instructions for the attendant console. Serves as a reference when defining the console control keys and Incoming Call Identification requirements.

**DEFINITY® Communications System Generic 1 and Generic 3—  
Voice Terminal Operations** **555-230-701**

Describes all the voice features and provides the “how-to-operate” instructions for each voice terminal. Serves as a reference when defining user requirements.

**DEFINITY® Communications System Generic 1 and Generic 3—  
Automatic Call Distribution (ACD)—Agent Instructions** **555-230-722**

Provides information for use by agents after training is completed. The various ACD features are described and the procedures for using them are provided in this document. The information in this document applies to DEFINITY Generic 1 and Generic 3 systems.

**DEFINITY® Communications System  
Generic 1 and Generic 3—Hospitality Operations** **555-230-723**

Contains the procedures for using the system’s hospitality services. These services include a group of system-based features that support the lodging industry. Hotels and motels use the features to improve their property management and to provide assistance to their employees and clients.

**DEFINITY® Communications System Generic 1 and Generic 3—  
Automatic Call Distribution (ACD)—Supervisor Instructions** **555-230-724**

Provides information for use by supervisors after training is completed. The various ACD features are described and the procedures for using them are provided in this document. The information in this document applies only to DEFINITY Generic 1 and Generic 3 systems.

**DEFINITY® Communications System  
Generic 1 and Generic 3—Installation and Test** **555-230-104**

Provides the information necessary to perform the tasks of installing and testing the system’s common equipment. Includes a description of the necessary tools and equipment.

**DEFINITY® Communications System Generic 1 and Generic 3i—Maintenance 555-204-105**

Provides the information necessary for monitoring, testing, and maintaining the system. It is intended to cover many of the faults and troubles that can occur in the DEFINITY Generic 1 and Generic 3i systems.

**DEFINITY® Communications System Generic 3r—Maintenance 555-230-105**

Provides the information necessary for monitoring, testing, and maintaining the system. It is intended to cover many of the faults and troubles that can occur in the DEFINITY Generic 3r system.

**DEFINITY® Communications System Generic 1 and Generic 3i—Upgrades and Additions 555-204-106**

Provides procedures and information for upgrading or making additions to an operational system after the initial switch installation. The document covers upgrades to Generic 1 from System 75 and to Generic 3i from Generic 1 systems.

**DEFINITY® Communications System Generic 3r—Upgrades and Additions 555-230-106**

Provides procedures and information for upgrading or making additions to an operational system after the initial switch installation. The document covers upgrades to Generic 3r from Generic 3i systems.

**DEFINITY® Communications System Generic 1 and Generic 3i—Wiring 555-204-111**

Provides the information necessary for installing inside wiring.

**DEFINITY® Communications System Generic 1 and Generic 3—System Description 555-230-200**

Provides a technical description of the system hardware, environmental and space requirements, and parameters. This document also provides a brief description of features and services.

**DEFINITY® Communications System Generic 3i—Implementation 555-230-650**

Provides the procedures and associated forms for collecting system and terminal software information. This information is later used to initialize the system via the Manager I or G3r-MT terminal.

**DEFINITY® Communications System Generic 3r—Implementation 555-230-651**

Provides the procedures and associated forms for collecting system and terminal software information. This information is later used to initialize the system via the Manager I or G3r-MT terminal.

## ABBREVIATIONS AND ACRONYMS

AAR	Automatic Alternate Routing
AC	Alternating Current
ACA	Automatic Circuit Assurance
ACD	Automatic Call Distribution
ACU	Automatic Call Unit
ACW	After Call Work
AD	Abbreviated Dialing
ADU	Asynchronous Data Unit
AIM	Asynchronous Interface Module
ALM-ACK	Alarm Acknowledge
AMW	Automatic Message Waiting
AN	Analog
ANI	Automatic Number Identification
AP	Applications Processor
APLT	Advanced Private Line Termination
ARS	Automatic Route Selection
ASAI	Adjunct Switch Application Interface
ASCII	American Standard Code for Information Interchange
ATB	All Trunks Busy
AUDIX	Audio Information Exchange
AVD	Alternate Voice Data
AWG	American Wire Gauge
AWT	Average Work Time
BCC	Bearer Capability Class
BCMS	Basic Call Management System
BCS	Business Communications System
BCT	Business Communications Terminal
BDC	Business Communication Systems Design Center
BHCC	Busy Hour Call Completions
BLF	Busy Lamp Field
BOS	Bit Oriented Signaling
BRI	Basic Rate Interface
BTU	British Thermal Unit
CACR	Cancellation of Authorization Code Request
CAG	Call Answer Group
CAMA	Centralized Automatic Message Accounting
CAS	Centralized Attendant Service
CBC	Call-By-Call
CCITT	Consultative Committee for International Telephone and Telegraph
CCMS	Common Channel Message Set
CCS	Hundred Call Seconds
CCSA	Common Control Switching Arrangement

CDM	Channel Division Multiplexing
CDOS	Customer-Dialed and Operator-Serviced
CDR	Call Detail Recording
CDRR	Call Detail Recording and Reporting
CDRU	Call Detail Recording Utility
CEM	Channel Expansion Multiplex
CI	Clock Input
CMDR	Centralized Message Detail Recorder
CMS	Call Management System
CO	Central Office
COR	Class of Restriction
COS	Class of Service
CPE	Customer Premises Equipment
CPN/BN	Calling Party Number/Billing Number
CPS	Characters Per Second
CPTR	Call Progress Tone Receiver
CRC	Cyclical Redundancy Checking
CSA	Canadian Safety Association
CSD	Customer Service Document
CSM	Centralized System Management
CSS	Center Stage Switch
CSU	Channel Service Unit
DC	Direct Current
DCE	Data Communications Equipment
DCP	Digital Communications Protocol
DCS	Distributed Communications System
DDC	Direct Department Calling
DDD	Direct Distance Dialing
DID	Direct Inward Dialing
DIOD	Direct Inward/Outward Dialing
DLC	Data Line Circuit
DLDM	Data Line Data Module
DMI	Digital Multiplexed Interface
DND	Do Not Disturb
DNIS	Dialed Number Identification Service
DOD	Direct Outward Dialing
DOSS	Delivery Operations Support System
DS1	Data Services Level 1
DSI	Digital Service Interface
DSU	Data Service Unit
DTDM	Digital Terminal Data Module
DTE	Data Terminal Equipment
DTGS	Direct Trunk Group Select
DTMF	Dual Tone Multifrequency
DXS	Direct Extension Selection
E&M	Ear and Mouth (Receive and Transmit)

EBCDIC	Extended Binary Coded Decimal Interexchange Code
EI	Expansion Interface
EIA	Electronic Industries Association
EMI	Electro-Magnetic Interference
EPN	Expansion Port Network
EPROM	Erasable Programmable Read Only Memory
EPSCS	Enhanced Private Switched Communications Services
ESF	Extended Superframe Format
ETN	Electronic Tandem Network
FAC	Feature Access Code
FAS	Facility Associated Signaling
FCC	Federal Communications Commission
FIC	Facility Interface Codes
FNPA	Foreign Numbering Plan Area Code
FRL	Facility Restriction Level
FSAC	Field Support Administration Center
FX	Foreign Exchange
GPTR	General Purpose Tone Receiver
GRS	Generalized Route Selection
HNPA	Home Numbering Plan Area Code
IAS	Inter-PBX Attendant Service
IC	Inter-Cabinet
ICC	Inter-Carrier Cable
ICI	Incoming Call Identifier
ICM	Inbound Call Management
IDDD	International Direct Distance Dialing
IDI	Isolating Data Interface
IE	Information Element
INADS	Initialization and Administration System
INS	ISDN Network Service
INWATS	Inward Wide Area Telephone Service
ISDN	Integrated Services Digital Network
ISDN-BRI	Integrated Services Digital Network-Basic Rate Interface
ISDN-PRI	Integrated Services Digital Network-Primary Rate Interface
ISN	Information Systems Network
ITP	Installation Test Procedure
IXC	Inter-Exchange Carrier Code
KBPS	Kilobits Per Second
LAN	Local Area Network
LDN	Listed Directory Number
LED	Light-Emitting Diode
LSU	Local Storage Units

LWC	Leave Word Calling
M-Bus	Memory Bus
MA-UUI	Message Associated User-to-User Signaling
MBPS	Megabits Per Second
MCC	Multi-Carrier Cabinet
MCS	Message Center Service
MDM	Modular Data Module
MDR	Message Detail Record
MET	Multibutton Electronic Telephone
MIS	Management Information System
MISCID	Miscellaneous Identification
MMS	Material Management Services
MOS	Message Oriented Signaling
MS	Message Server
MSA	Message Service Adjunct
MPDM	Modular Processor Data Module
MTDM	Modular Trunk Data Module
MTP	Maintenance Tape Processor
MTT	Multi-Tasking Terminal
MWL	Message Waiting Lamp
NAU	Network Access Unit
NCOSS	Network Control Operations Support Center
NCISO	National Customer Support Organization
NFAS	Non-Facility Associated Signaling
NID	Network Inward Dialing
NPA	Numbering Plan Area Code
NPE	Network Processing Element
NQC	Number of Queued Calls
NSE	Night Service Extension
NSU	Network Sharing Unit
NXX	Public Network Office Code
OCM	Outbound Call Management
OPS	Off-Premises Station
OQT	Oldest Queued Time
OSHA	Occupational Safety and Health Act
OSS	Operations Support System
PBX	Private Branch Exchange
PC	Personal Computer
PCOL	Personal Central Office Line
PCOLG	Personal Central Office Line Group
PCM	Pulse Code Modulated
PCS	Permanent Switched Calls
PDM	Processor Data Module
PDS	Premises Distribution System

PE	Processing Element
PEC	Price Element Code
PGN	Partitioned Group Number
PIB	Processor Interface Board
PL	Private Line
PMS	Property Management System
PN	Port Network
PNA	Private Networking Automatic Alternate Routing
PPN	Processor Port Network
PRI	Primary Rate Interface
PSC	Premises Service Consultant
PSDN	Packet Switch Public Data Network
PT	Personal Terminal
RAM	Random Access Memory
RCL	Restricted Call List
RHNPA	Remote Home Numbering Plan Area Code
RLT	Release Link Trunk
RNX	Private Network Office Code
ROM	Read Only Memory
RPN	Routing Plan Number
SAKI	Sanity and Control Interface
SCC	Single Carrier Cabinet
SCI	Switch Communications Interface
SCO	System Control Office
SDDN	Software Defined Data Network
SDN	Software Defined Network
SID	Station Identification Number
SIT	Special Information Tones
SMDR	Station Message Detail Recording
SPE	Switch Processing Element
SPID	Service Profile Identifier
SSI	Standard Serial Interface
STARLAN	Star-based Local Area Network
ST3	Stratum 3 Clock Board
TAAS	Trunk Answer From Any Station
TAC	Trunk Access Code
TC	Technical Consultant
TCM	Traveling Class Mark
TDM	Trunk Data Module
TEG	Terminating Extension Groups
TOD	Time of Day
TOP	Task Oriented Protocol
TSC	Technical Service Center
TTR	Touch-Tone Receiver
TTTTN	Tandem Tie Trunk Network



## ABBREVIATIONS AND ACRONYMS

---

TTY	Teletypewriter
UAP	Usage Allocation Plan
UCD	Uniform Call Distribution
UCL	Unrestricted Call List
UDP	Uniform Dial Plan
UPS	Uninterruptible Power Supply
VDN	Vector Directory Number
VM	Voltmeter
WATS	Wide Area Telecommunications Service
WGS	WorkGroup System

## GLOSSARY

### A

---

#### **Access Code**

A 1-, 2-, or 3-digit dial code used to activate or cancel a feature or access an outgoing trunk. The star (\*) and pound (#) can be used as the first digit of an access code.

#### **Access Endpoint**

Either a non-signaling channel on a DS1 interface or a non-signaling port on an Analog Tie Trunk circuit pack that is assigned a unique extension.

#### **Access Tie Trunks**

Tie trunks used to handle normal Electronic Tandem Network (ETN) calls between main and tandem switches.

#### **Adjunct Switch Application Interface (ASAI)**

An AT&T recommendation for interfacing adjuncts and communications systems, based on the CCITT Q.932 specification for layer 3.

#### **Administer**

To access and change the parameters associated with the services or features of the system.

#### **Answer-Back Code**

A code dialed to retrieve a parked call.

#### **Appearance**

*See Call Appearance.*

#### **Asynchronous Data Transmission**

A scheme for transmitting data where each character is preceded by a start bit and followed by a stop bit, thus permitting data elements to occur at irregular intervals. This type transmission is advantageous when transmission is not regular (characters typed at a keyboard).

#### **Asynchronous Data Unit (ADU)**

A data communications equipment (DCE)-type device that allows direct connection between EIA-232C equipment and the system digital switch.

### **Attendant**

The operator of the console.

### **Applications Processor**

A minicomputer used to support several user-controlled applications such as traffic analysis and electronic documentation.

### **Attendant Console**

An electronic call-handling position with pushbutton control. Used by attendants to answer and place calls and to manage and monitor some of the system operations.

### **Audio Information Exchange (AUDIX)**

A unit that provides voice mail service to users.

### **Automatic Trunk**

A trunk that does not require the sending or receiving of digits. The destination is predetermined. A request for service on the trunk (called a seizure) is sufficient to route the call. The normal destination of an automatic trunk is the system attendant group.

### **Automatic Restoration**

A service that restores disrupted connections between access endpoints (non-signaling trunks) and data endpoints (devices that connect the switch to data terminal/communications equipment). This restoration is achieved within seconds of a service disruption so that critical data applications can remain operational.

## **B**

---

### **Barrier Code**

A security code used with the Remote Access feature to prevent unauthorized access to the system.

### **Bit (Binary Digit)**

One unit of information in binary notation (having two possible states or values, zero or one).

### **Bridge (Bridging)**

The appearance of a voice terminal's extension at one or more other voice terminals.

**Bridged Appearance**

A call appearance on a voice terminal that matches a call appearance on another voice terminal for the duration of a call.

**Buffer**

A circuit or component that isolates one electrical circuit from another. Typically, a buffer holds data from one circuit or process until another circuit or process is ready to accept the data.

**Bus**

A multi-conductor electrical path used to transfer information over a common connection from any of several sources to any of several destinations.

**Bus, Time Division Multiplex**

See **Time Division Multiplex Bus**.

**Business Communications Terminal**

An advanced series of semi-intelligent terminals.

**Bypass Tie Trunks**

One-way, outgoing tie trunks from a tandem switch to a main switch in an Electronic Tandem Network (ETN). These trunks, provided in limited quantities, are used as a "last-choice" route when all trunks to another tandem switch are busy. Bypass tie trunks are used only if all applicable intertandem trunks are busy.

**Byte**

A sequence of bits, 8 bits long, that is usually shorter than a word. A word is 16 bits long.

**C**

---

**Call Appearance, Attendant Console**

Six buttons, labeled a through f, used to originate, receive, and hold calls. Each button has two associated lamps to show the status of the call appearance.

**Call Appearance, Voice Terminal**

A button labeled with an extension number used to place outgoing calls, receive incoming calls, or hold calls. Two lamps next to the button show the status of the call appearance or status of the call.

### **Call Management System (CMS)**

An adjunct processor that collects data from an ACD and generates reports to be stored or displayed concerning status of agents, splits, and trunks.

### **Callback Call**

A call that is automatically returned to a voice terminal user who activated the Automatic Callback or Ringback Queuing feature.

### **Call Vector**

A set of up to 15 vector commands to be performed for an incoming or internal call.

### **Call Waiting Ringback Tone**

A low-pitched tone identical to the ringback tone except that the tone decreases during the last 0.2 second. This tone notifies the attendant that the Attendant Call Waiting feature has been activated and that the called user is aware of the waiting call.

### **Call Work Code**

A number, up to 16 digits, entered by ACD agents to record the occurrence of customer-defined events (such as account codes, social security numbers, or phone numbers) on ACD calls.

### **Central Office (CO)**

The location housing telephone switching equipment that provides local telephone service and access to toll facilities for long-distance calling.

### **Central Office Codes**

The first three digits of a 7-digit public network telephone number. These codes are numbered from 200 through 999.

### **Central Office Trunk**

A telecommunications channel that provides access from the system to the public network through the local central office.

### **Channel**

A communications path for transmitting voice and data.

### **Class of Restriction (COR)**

A number (0 through 63) that specifies the restrictions assigned to voice terminals, voice terminal groups, data modules, and trunk groups.

**Class of Service (COS)**

A number (0 through 15) that specifies if voice terminal users can activate the Automatic Callback, Call Forwarding—All Calls, Data Privacy, or Priority Calling features.

**Common Control Switching Arrangement (CCSA)**

A private telecommunications network using dedicated trunks and a shared switching center for interconnecting company locations.

**Confirmation Tone**

Three short bursts of tone followed by silence; indicates that the feature activated, deactivated, or canceled has been accepted.

**Console**

See **Attendant Console**.

**Coverage Answer Group**

A group of up to eight voice terminals that ring simultaneously when a call is redirected to it by Call Coverage. Any one of the group can answer the call.

**Coverage Call**

A call that is automatically redirected from the called party's extension number to an alternate answering position when certain coverage criteria are met.

**Coverage Path**

The order in which calls are redirected to alternate answering positions.

**Coverage Point**

The attendant positions (as a group), Direct Department Calling group, Uniform Call Distribution group, Coverage Answer Group, a voice terminal extension, or Message Center Hunt Group designated as an alternate answering position in a coverage path.

**Covering User**

The person at an alternate answering position who answers a coverage call.

**D**

---

**Data Channel**

A communications path between two points used to transmit digital signals.

### **Data Communications Equipment (DCE)**

The equipment on the network side of a communication link that provides all the functions required to make the binary serial data from the source or transmitter compatible with the communications channel.

### **Data Terminal Equipment (DTE)**

Equipment comprising the source or link of data, or both, that also provides communication control functions (protocol). DTE is any piece of equipment at which a communications path begins or ends.

### **Delay-Dial Trunk**

After a request for service (called a seizure) is detected on an incoming trunk, the system sends a momentary signal followed by a steady tone over the trunk. This informs the calling party that dialing can start. This type of trunk allows dialing directly into the system. That is, the digits are received as they are dialed.

### **Designated Voice Terminal**

The specific voice terminal to which calls, originally directed to a certain extension number, are redirected. Commonly used to mean the “forwarded-to” terminal when Call Forwarding All Calls is active.

### **Dial Repeating Tie Trunk**

A telecommunications channel between two private switching systems. The number dialed is repeated or dialed-in at the distant end.

### **Digital Communications Protocol (DCP)**

Defines the capability for providing simultaneous voice and data transmission over the same channel.

### **Digital Data Endpoints**

In DEFINITY Generic 1, digital data endpoints include the following:

- 510D Personal Terminal or 515-Type Business Communications Terminal
- 7404D Terminals
- 7406D or 7407D Equipped With Optional Data Module Base
- Asynchronous Data Units
- Digital Terminal Data Modules
- Modular Processor Data Modules
- Modular Trunk Data Modules
- 3270 Data Modules
- Internal Data Channels

**Digital Multiplexed Interface (DMI)**

Specifies the remote interface requirements for multiplexed data communications between a host computer and a private switching system.

**Digital Terminal Data Module (DTDM)**

An adjunct to Model 7403D or 7405D voice terminals. Provides the required interface between the system and a data terminal such as a 513 BCT.

**Digital Trunk**

A circuit in a telecommunications channel designed to handle digital voice and data.

**Digit Conversion**

A process used to convert specific dialed numbers into other dialed numbers. ARS uses Digit Conversion to convert public network numbers (ARS) to private network numbers (AAR) in order to save toll charges. AAR uses Digit Conversion to convert private network numbers (ARS) to other private or public network numbers (AAR).

**Direct Extension Selection (DXS)**

An option at the attendant console that allows an attendant direct access to voice terminals by pressing a Group Select button and a DXS button.

**Distributed Communications System (DCS)**

A network of two or more switches, each with its terminals and trunks, configured to function as a single large system.

**E**

---

**Electronic Tandem Network (ETN)**

A special tandem tie trunk network that has automatic call routing capabilities based on the number dialed and most preferred route available at the time the call is placed. Each switch in the network is assigned a unique private network office code (RNK) and each voice terminal is assigned a unique extension number.

**End-to-End Signaling**

The transmission of touch-tone signals generated by dialing from a voice terminal user to remote computer equipment. A connection must first be established over an outgoing trunk from the calling party to the computer equipment. Then additional digits can be dialed to transmit information to be processed by the computer equipment.



**Enhanced Private Switched Communications Service (EPSCS)**

A private telecommunications network that provides advanced voice and data telecommunications services to companies with many locations.

**Extension Number**

A 1- to 5-digit number assigned to each voice terminal, certain system groups, data modules, 510D Personal Terminals, or 515 BCTs within the system. A 1- or 5-digit extension number is available for Version 2 and Version 3.

**External Call**

A connection between a system user and a party on the public telephone network or on a tie trunk.

**F**

---

**Facility**

A general term used for the telecommunications transmission pathway and associated equipment.

**Feature**

A specifically defined function or service provided by the system.

**Feature Button**

A labeled button on a voice terminal or attendant console designating a specific feature.

**Foreign Exchange (FX)**

A central office other than the one providing local access to the public telephone network.

**Foreign Exchange Trunk**

A telecommunications channel that directly connects the system to a central office other than its local central office.

**Foreign Numbering Plan Area Code (FNPA)**

An area code other than the local area code. The foreign area code must be dialed to call outside the local geographical area.

**G**

---

**Ground-Start Trunk**

On outgoing calls, the system transmits a request for services to the distant switching system by grounding the trunk ring lead. When the distant system is ready to receive the digits of the called number, that system grounds the trunk tip lead. When the system detects this ground, the digits are sent. (Tip and ring are common nomenclature to differentiate between ground-start trunk leads.) On incoming calls, detection of ground on the ring lead is sufficient to cause the call to route to a predetermined destination, normally the system attendant group. No digits are received.

**H**

---

**Handshaking Logic**

A format used to initiate a data connection between two data module devices.

**Home Numbering Plan Area Code (HNPA)**

The local area code. The area code does not have to be dialed to call numbers within the local geographical area.

**I**

---

**Immediate-Start Tie Trunk**

After establishing a connection with the distant switching system for an outgoing call, the system waits a nominal 65 milliseconds before sending the digits of the called number. This allows time for the distant system to prepare to receive the digits. Similarly, on an incoming call, the system has less than 65 milliseconds to prepare to receive the digits.

**Information Exchange**

The exchange of data between users of two different systems (DEFINITY G1 and host computer) over a local area network.

**In-Use Lamp**

A red lamp on a multi-appearance voice terminal that lights to show which call appearance will be selected when the handset is lifted or which call appearance is active when a user is off-hook.

**Intercept Tone**

An alternating high and low tone; indicates a dialing error or denial of the service requested.

### **Interface**

A common boundary between two systems or pieces of equipment.

### **Internal Call**

A connection between two users within the system.

### **ISDN Gateway**

An adjunct network that forwards information from the switch to a host for data screen delivery to agents in an ACD split.

## **L**

---

### **Link**

A transmitter-receiver channel or system that connects two locations.

### **Loop-Start Trunk**

After establishing a connection with the distant switching system for an outgoing call, the system waits for a signal on the loop formed by the trunk leads before sending the digits of the called number. On incoming calls, the received request for service is sufficient to cause the call to route to a predetermined destination, normally the system attendant group. No digits are received.

## **M**

---

### **Main/Satellite/Tributary**

A main switch provides interconnection, via tie trunks, with one or more subtending switches, called satellites; all attendant positions for the main/satellite configuration, and access to and from the public network. To a user outside the complex, a main/satellite configuration appears as a single switch, with a single Listed Directory Number (LDN). A tributary is a switch, connected to the main switch via tie trunks, but which has its own attendant position(s) and its own LDN.

### **Message Center**

An answering service for calls that might otherwise go unanswered; an agent accepts and stores messages for later retrieval. (Requires an Applications Processor.)

### **Message Center Agent**

A member of the Message Center Hunt Group who takes and retrieves messages for voice terminal users.

**Modular Processor Data Module (MPDM)**

*See Processor Data Module.*

**Modular Trunk Data Module (MTDM)**

*See Trunk Data Module.*

**Modem Pooling**

Provides shared-use conversion resources that eliminate the need for a dedicated modem when a data module accesses, or is accessed by, an analog line or trunk.

**Multi-Appearance Voice Terminal**

A terminal equipped with several call appearance buttons for the same extension number. Allows the user to handle more than one call, on that same extension number, at the same time.

**Multiplexer**

A device for simultaneous transmission of two or more signals over a common transmission medium.

**N**

---

**Network**

An arrangement of inter- and/or intra-location circuits designed to perform specific functions.

**P**

---

**Paging Trunk**

A telecommunications channel used to access an amplifier for loudspeaker paging.

**Pickup Group**

A group of individuals authorized to answer any call directed to an extension number within the group.

**Port**

A designation of the location of a circuit that provides an interface between the system and lines and/or trunks.

**Principal (User)**

In terms of Call Coverage, a person for whom a call was originally intended.

**Private Network**

A network used exclusively for handling the telecommunications needs of a particular customer.

**Private Network Office Code (RNX)**

The first three digits of a 7-digit private network number. These codes are numbered 220 through 999, excluding any codes that have a zero or one as the second digit.

**Processor Data Module (PDM)**

Provides the required interface between the system and an EIA computer or data terminal.

**Property Management System (PMS)**

A stand-alone computer which lodging and health services organizations use for services such as reservations, housekeeping, billing, etc.

**Protocol**

A set of conventions or rules governing the format and timing of message exchanges to control data movement and correction of errors.

**Public Network**

The network that can be openly accessed by all customers for local or long-distance calling.

**Q**

---

**Queue**

An ordered sequence of calls waiting to be processed.

**Queuing**

The process of holding calls in order of their arrival to await connection to an attendant, to an answering group, or to an idle trunk. Calls are automatically connected in first-in, first-out sequence.

**R**

---

**Random Access Memory (RAM)**

A storage arrangement whereby information can be retrieved at a speed independent of the location of the stored information.

**Read Only Memory (ROM)**

A storage arrangement primarily for information retrieval applications.

**Recall Dial Tone**

Three short bursts of tone followed by steady dial tone; indicates that the system has completed some action (such as holding a call) and is ready to accept dialing.

**Redirection Criteria**

The information administered for each voice terminal's coverage path that determines when an incoming call is redirected to coverage.

**Remote Home Numbering Plan Area Code (RHNPA)**

A foreign numbering plan area code that is treated as a home area code by the Automatic Route Selection feature. Calls can be allowed or denied based on the area code and the dialed central office code rather than just the area code. If the call is allowed, the Automatic Route Selection pattern used for the call is determined by these six digits.

**Removable Mass Storage Subsystem (RMSS)**

A tape storage device that stores the software information for the system.

**Reorder Tone**

A fast-busy tone repeated 120 times a minute; indicates that at least one of the facilities, such as a trunk or a digit transmitter, required for the call was not available at the time the call was placed.

**S**

---

**Service Profile Identifier (SPID)**

A unique number of up to 10 digits, assigned to an Integrated Services Digital Network (ISDN) terminal, that will be used for terminal identification during level-3 initialization.

### **Single-Line Voice Terminals**

Voice terminals served by a single-line tip and ring circuit (Models 500, 2500, 7101A, 7103A).

### **Software**

A set of computer programs that accomplish one or more tasks.

### **Split**

A condition whereby a caller is temporarily separated from a connection with the attendant. This split condition automatically occurs when the attendant, active on a call, presses the Start button.

### **Standard Serial Interface (SSI)**

A communications protocol developed by AT&T Teletype Corporation for use with the 500-series Business Communications Terminals and the 400-series printers.

### **Status Lamp**

A green lamp that shows the status of a call appearance or a feature button by the state of the lamp (lighted, flashing, fluttering, broken flutter, or dark).

### **Stroke Counts**

Method used by ACD agents to record up to nine customer-defined events on a per-call basis when the Call Management System (CMS) is active.

### **Switchhook**

The button(s) on a voice terminal located under the receiver.

### **Synchronous Data Transmission**

A scheme for sending and receiving data, where data elements may occur only at regular specified times. Sending and receiving devices must operate in step with each other.

### **System Manager**

A person responsible for specifying and administering features and services for the system.

### **System Reload**

A process that allows stored data to be written from a tape into the system memory (normally after a power outage).

**T**

---

**Tandem Switch**

A switch within an Electronic Tandem Network (ETN) that provides the logic to determine the best route for a network call, possibly modifies the digits outpulsed, and allows or denies certain calls to certain users.

**Tandem Through**

The switched connection of an incoming trunk to an outgoing trunk without human intervention.

**Tandem Tie Trunk Network (TTTN)**

A private network that interconnects several customer switching systems by dial repeating tie trunks. Access to the various systems is dictated by codes that must be individually dialed for each system.

**Tie Trunk**

A telecommunications channel that directly connects two private switching systems.

**Time Division Multiplex Bus**

A special bus that is time shared by preallocating short time slots to each transmitter on a regular basis. In a PBX, all port circuits are connected to the time division multiplex bus permitting any port to send a signal to any other port.

**Tone Ringer**

A device with a speaker, used in electronic voice terminals to alert the user.

**Trunk**

A telecommunications channel between two switching systems.

**Trunk Data Module (TDM)**

Provides the required interface between the system and a data set (modem) or data service unit connected to a private or switched data line.

**Trunk Group**

Telecommunications channels assigned as a group for certain functions.



**U**

---

**Uniform Dial Plan (UDP)**

A feature that allows a unique 4- or 5-digit number assignment for each terminal in a multi-switch configuration, such as a Distributed Communications System (DCS) or a Main/Satellite/Tributary configuration.

**V**

---

**Voice Terminal**

A single-line or multi-appearance voice instrument (telephone).

**W**

---

**Wide Area Telecommunications Service (WATS)**

A service that allows calls to a certain area or areas for a flat-rate charge based on expected usage.

**Wink-Start Tie Trunk**

After establishing a connection with a distant switching system for an outgoing call, the system waits for a momentary signal (wink) before sending the digits of the called number. Similarly, on an incoming call, the system sends the wink signal when ready to receive digits.

**Write Operation**

The process of putting information onto a storage medium such as magnetic tape.

## Index

### A

AAR/ARS Partitioning, 8  
 Abandoned Call Search, 7, 12  
 Abbreviated Dialing, 7, 12  
 AC Power Requirements, 115  
 Acoustic Noise Levels, 113  
 Additions  
     General, 135  
 Adjunct Quantities, 49  
 Administered Connection/Access  
     Endpoint, 7, 13  
 Agent Call Handling, 7, 13  
 Air Purity  
     Equipment Room, 112  
 Air Requirements  
     Equipment Room, 111  
 Alphanumeric Dialing, 7  
 Alternate Facility Restriction Levels, 7  
 Analog Line Interface  
     TN479, 83  
     TN742, 79  
     TN746, 82  
     TN769, 84  
 Announcement Circuit Pack (TN750), 91  
 Attendant  
     Call Waiting, 7  
     Control of Trunk Group Access, 7  
     Direct Extension Selection With Busy  
         Lamp Field, 7  
     Direct Trunk Group Selection, 7  
     Display, 7  
     Recall, 7  
     Release Loop Operation, 7  
 Attendant Console  
     Replacement, 141  
 Audio Information Exchange (AUDIX)  
     Interface, 7, 13  
 Authorization Codes, 7, 14  
 Automatic  
     Callback, 8  
     Incoming Call Display, 8, 14  
     Wakeup, 8, 15  
 Automatic Alternate Routing (AAR), 8, 14  
 Automatic Available Split, 8  
 Automatic Call Distribution (ACD), 8, 14

Automatic Circuit Assurance (ACA), 8  
 Automatic Route Selection (ARS), 14  
     Partitioning, 14  
 Automatic Trunk Measurement System, 8  
 Auxiliary Trunk  
     TN763, 85

### B

Basic Call Management System  
     (BCMS), 8, 15  
 Battery Backup  
     Multi-Carrier System, 131  
     Single-Carrier System, 133  
 Battery Reserve, 132  
 Bridged Call Appearance  
     Multi-Appearance Voice Terminal, 8  
     Single-Line Voice Terminal, 8  
 Bulk Station Administration, 8  
 Busy Verification of Terminals and Trunks, 8

### C

Cabinet Additions, 149  
 Call  
     Coverage, 8  
     Forwarding All Calls, 8  
     Park, 8  
     Pickup, 8  
     Waiting Termination, 8  
 Call Classifier  
     TN744, 81  
 Call Detail Recording (CDR), 8, 15, 16  
     Account Code Dialing, 8  
     Output Devices and Connections, 53  
     Variable Format Reports, 8  
 Call Party Number/Billing Number  
     (CPN/BN), 8, 17  
 Call Prompting, 8, 17  
 Call Vectoring, 8, 17  
 Call-By-Call Service Selection, 8, 15  
 CallVisor Adjunct Switch Application  
     Interface (ASAI), 7, 12

- Central Office Trunk
    - TN465, 86
    - TN747, 85
  - Centralized Attendant Service (CAS)
    - Branch, 8
    - Branch or Main, 17
  - Circuit Packs
    - Additions, 149
    - Analog Line Interface (TN769), 84
    - Analog Line (TN479), 83
    - Analog Line (TN742), 79
    - Analog Line (TN746), 82
    - Announcement (TN750), 91
    - Auxiliary Trunk (TN763), 85
    - Call Classifier (TN744), 81
    - Central Office Trunk (TN465), 86
    - Central Office Trunk (TN747), 85
    - Data Line (TN726), 86
    - Determination, 75
    - Digital Line (TN754), 87
    - Direct Inward Dialing (DID)
      - Trunk (TN429), 88
    - Direct Inward Dialing (DID)
      - Trunk (TN753), 88
    - Disk Drive (TN1657), 76
    - DS1 Digital Trunk (TN464), 90
    - DS1 Digital Trunk (TN767), 89
    - DS1/DMI Digital Trunk (TN722), 89
    - For PPN, Upgrades, 141
    - Hybrid Line (TN762), 91
    - Integrated Pooled Modem (TN758), 91
    - ISDN-BRI Line (TN556), 77
    - MET Line (TN735), 92
    - Packet Data Line (TN553), 76
    - Packet Gateway (TN577), 78
    - Speech Synthesizer (TN725), 92
    - Summation of, 94
    - Tie Trunk (TN760), 92
    - Tone Clock (TN741 or TN768), 93
    - Tone Clock (TN780), 93
    - Tone Detector (TN748), 93
  - Class of Restriction (COR), 8
  - Class of Service (COS), 8
  - Code Calling Access, 8, 18
  - Conference
    - Attendant, 8
    - Terminal, 8
  - Consult, 8
  - Coverage
    - Callback, 8
    - Incoming Call Identification, 8
  - Cross-Connect Field, 133
  - Customer-Provided Equipment (CPE)
    - Alarm, 8
- D**
- Data
    - Call Setup, 8, 18
    - Communications Adjuncts, 58
    - Hot Line, 8
    - Modules, 55
    - Modules, 7400A, 56
    - Modules, 7400B, 56
    - Modules, 7500B, 56
    - Privacy, 8
    - Restriction, 8
    - Terminals, System, 62
  - Data Communications Equipment (DCE), 52
  - Data Line Circuit Pack (TN726), 86
  - Data-Only Off-Premises Extensions, 8, 19
  - Data/Voice Terminal
    - Equipment Assignments, 45
    - Totals, 45
  - DC Power
    - Multi-Carrier Cabinet System, 122
    - Requirements, Equipment Room, 122
    - Single-Carrier Cabinet System, 127
  - D-Channel Backup, 8, 18
  - Default Dialing, 9
  - Desktop Space
    - Equipment Room, 110
  - Dial Access to Attendant, 9
  - Dial Plan, 9
  - Dialed Number Identification Service (DNIS), 9, 19
  - Digital Line Circuit Pack (TN754), 87
  - Digital Multiplexed Interface (DMI), 9, 19
  - Direct Department Calling and Uniform Call Distribution, 9, 19
  - Direct Inward Dialing (DID), 9, 20
    - Trunk Circuit Pack (TN429), 88
    - Trunk Circuit Pack (TN753), 88
  - Direct Outward Dialing (DOD), 9, 20
  - Disk Drive
    - TN1657, 76

Display Terminals and Printers, 61  
 Distinctive Ringing, 9  
 Distributed Communications System  
   (DCS), 19, 65  
   Alphanumeric Display for Terminals, 9  
   Attendant Control of Trunk Group Access, 9  
   Attendant Direct Trunk Group Selection, 9  
   Attendant Display, 9  
   Automatic Callback, 9  
   Automatic Circuit Assurance (ACA), 9  
   Busy Verification of Terminals and Trunks, 9  
   Call Forwarding All Calls, 9  
   Call Waiting, 9  
   Distinctive Ringing, 9  
   Leave Word Calling, 9  
   Multi-Appearance Conference/Transfer, 9  
   Trunk Group Busy/Warning Indication, 9  
 Distribution  
   Wiring, 133  
 Do Not Disturb, 9, 20  
 Documents  
   Reference, 151  
 DS1  
   Digital Trunk Circuit Pack (TN464), 90  
   Digital Trunk Circuit Pack (TN767), 89  
   Tie Trunk Service, 9, 20  
 DS1/DMI  
   Digital Trunk Circuit Pack (TN722), 89

## E

Earthquake Protection, 104  
 EIA Interface, 9, 20  
 Electrical Requirements  
   Equipment Room, 112  
 Emergency Access to Attendant, 9, 20  
 Enhanced Trunk Signaling and Error  
   Recovery, 9  
 EPN Upgrade  
   From System 75 to, 137  
 EPN With Duplication  
   Upgrade To, 144, 146  
 EPN Without Duplication  
   Upgrade To, 143  
 Equipment Assignments  
   Data/Voice Terminal, 45

Equipment Room  
   Air Purity, 112  
   Air Requirements, 111  
   DC Power Requirements, 122  
   Desktop Space, 110  
   Earthquake Protection, 104  
   Electrical Requirements, 112  
   Floor Loading, 103  
   Floor Plans and Layouts, 103  
   Floor Space, 104  
   Grounding, 128  
   Lighting, 112  
   Noise Levels, 113  
   Noise Suppression, 112  
   Power Requirements, 115  
   Requirements, 103  
   Wall Space Requirements, 110

## F

Facilities  
   Network Access, 73  
 Facility Busy Indication, 9  
 Facility Restriction Levels and Traveling  
   Class Marks, 9, 20  
 Facility Test Calls, 9  
 Features  
   AAR/ARS Partitioning, 8  
   Abandoned Call Search, 7, 12  
   Abbreviated Dialing, 7, 12  
   Administered Connection/Access  
     Endpoint, 7, 13  
   Agent Call Handling, 7, 13  
   Alphanumeric Dialing, 7  
   Alternate Facility Restriction Levels, 7  
   ARS Partitioning, 14  
   Attendant Call Waiting, 7  
   Attendant Control of Trunk Group Access, 7  
   Attendant Direct Extension Selection With  
     Busy Lamp Field, 7  
   Attendant Direct Trunk Group Selection, 7  
   Attendant Display, 7  
   Attendant Recall, 7  
   Attendant Release Loop Operation, 7  
   AUDIX Interface, 7, 13  
   Authorization Codes, 7, 14  
   Automatic Alternate Routing (AAR), 8, 14  
   Automatic Available Split, 8

- Automatic Call Distribution (ACD), 8, 14
- Automatic Callback, 8
- Automatic Circuit Assurance (ACA), 8
- Automatic Incoming Call Display, 8, 14
- Automatic Route Selection (ARS), 14
- Automatic Trunk Measurement System, 8
- Automatic Wakeup, 8, 15
- Basic Call Management System (BCMS), 8, 15
- Bridged Call Appearance, Multi-Appearance Voice Terminal, 8
- Bridged Call Appearance, Single-Line Voice Terminal, 8
- Bulk Station Administration, 8
- Busy Verification of Terminals and Trunks, 8
- Call Coverage, 8
- Call Detail Recording (CDR), 8, 15, 16
- Call Forwarding All Calls, 8
- Call Park, 8
- Call Party Number/Billing Number (CPN/BN), 8, 17
- Call Pickup, 8
- Call Prompting, 8, 17
- Call Vectoring, 8, 17
- Call Waiting Termination, 8
- Call-By-Call Service Selection, 8, 15
- CallVisor Adjunct Switch Application Interface (ASAI), 7, 12
- CDR Account Code Dialing, 8
- CDR Variable Format Reports, 8
- Centralized Attendant Service (CAS), Branch, 8
- Centralized Attendant Service (CAS), Branch or Main, 17
- Class of Restriction (COR), 8
- Class of Service (COS), 8
- Code Calling Access, 8, 18
- Conference, Attendant, 8
- Conference, Terminal, 8
- Consult, 8
- Coverage Callback, 8
- Coverage Incoming Call Identification, 8
- Customer-Provided Equipment (CPE) Alarm, 8
- Data Call Setup, 8, 18
- Data Hot Line, 8
- Data Privacy, 8
- Data Restriction, 8
- Data-Only Off-Premises Extensions, 8, 19
- D-Channel Backup, 8, 18
- DCS, 19
- DCS, Alphanumeric Display for Terminals, 9
- DCS, Attendant Control of Trunk Group Access, 9
- DCS, Attendant Direct Trunk Group Selection, 9
- DCS, Attendant Display, 9
- DCS, Automatic Callback, 9
- DCS, Automatic Circuit Assurance (ACA), 9
- DCS, Busy Verification of Terminals and Trunks, 9
- DCS, Call Forwarding All Calls, 9
- DCS, Call Waiting, 9
- DCS, Distinctive Ringing, 9
- DCS, Leave Word Calling, 9
- DCS, Multi-Appearance Conference/Transfer, 9
- DCS, Trunk Group Busy/Warning Indication, 9
- Default Dialing, 9
- Determination, 7
- Dial Access to Attendant, 9
- Dial Plan, 9
- Dialed Number Identification Service (DNIS), 9, 19
- Digital Multiplexed Interface (DMI), 9, 19
- Direct Department Calling and Uniform Call Distribution, 9, 19
- Direct Inward Dialing (DID), 9, 20
- Direct Outward Dialing (DOD), 9, 20
- Distinctive Ringing, 9
- Do Not Disturb, 9, 20
- DS1 Tie Trunk Service, 9, 20
- EIA Interface, 9, 20
- Emergency Access to Attendant, 9, 20
- Enhanced Trunk Signaling and Error Recovery, 9
- Facility Busy Indication, 9
- Facility Restriction Levels and Traveling Class Marks, 9, 20
- Facility Test Calls, 9
- Forced Entry of Account Codes, 9, 20
- Functional Scheduling Enhancements, 9
- Generalized Route Selection, 9, 20
- Go To Cover, 9
- Hold, 9
- Hot Line Service, 9
- Hunting, 9

- Inbound Call Management (ICM), 21
- Individual Attendant Access, 9
- Information System Network (ISN)
  - Interface, 9, 21
- Integrated Directory, 9
- Integrated Services Digital Network, Basic Rate Interface (ISDN-BRI), 9, 21
- Integrated Services Digital Network, Primary Rate Interface (ISDN-PRI), 9, 21
- Intercept Treatment, 10, 21, 22
- Intercom, Automatic, 10
- Intercom, Dial, 10
- Inter-PBX Attendant Calls, 10, 22
- Intraflow and Interflow, 10, 22
- Last Number Dialed, 10
- Leave Word Calling, 10
- Line Lockout, 10
- Loudspeaker Paging Access, 10, 22
- Loudspeaker Paging Access, Deluxe, 10, 22
- Main/Satellite Extended Trunk Access, 10
- Malicious Call Trace, 10
- Manual Message Waiting, 10
- Manual Originating Line Service, 10
- Manual Signaling, 10
- Modem Pooling, 10, 23
- Move Agents From CMS, 10, 23
- M-to-N Digit Conversion, 10, 22
- Multi-Appearance Preselection and Preference, 10
- Multiple Listed Directory Numbers, 10
- Multi-User System Management Access, 10
- Music-on-Hold Access, 10, 23
- Names Registration, 10, 23
- Network Access, Private, 10, 23
- Network Access, Public, 10, 23
- Night Service, Hunt Group, 10
- Night Service, Night Station Service, 10
- Night Service, Trunk Answer From Any Station, 10, 23
- Night Service, Trunk Group, 10
- Off-Premises Station, 10, 23
- Outgoing Trunk-to-Outgoing Trunk Transfer, 10
- PC/PBX Connection, 10
- Permanent Switched Calls, 10
- Personal Central Office Line (PCOL), 10, 23
- Personalized Ringing, 10
- Power Failure Transfer, 10, 24
- Priority Calling, 10
- Privacy, Attendant Lockout, 10
- Privacy, Manual Exclusion, 10
- Property Management System (PMS), 10, 24
- Queue Status Indication, 10, 24
- Recall Signaling, 10
- Recent Change History, 10
- Recorded Announcement, 11, 24
- Recorded Telephone Dictation Access, 11, 25
- Remote Access, 11, 25
- Remote Administration, 11, 61
- Report Scheduler and System Printer, 11, 25
- Requiring Additional Hardware and/or Software, 12
- Restriction, Controlled, 11
- Restriction, Miscellaneous Terminal, 11
- Restriction, Miscellaneous Trunk, 11
- Restriction, Toll/Code, 11
- Restriction, Voice Terminal, 11
- Ringback Queuing, 11
- Ringer Cutoff, 25
- Rotary Dialing, 11
- Send All Calls, 11
- Senderized Operation, 11
- Service Observing, 11, 26
- Single-Digit Dialing and Mixed-Station Numbering, 11
- Station Identification/Automatic Number Identification, 11, 26
- Straightforward Outward Completion, 11
- Subnet Trunking, 11, 26
- System Measurements, 11
- System Reload Indication, 11
- System Status Report, 11
- Temporary Bridged Appearance, 11
- Ten Digit-to-Seven Digit Conversion, 11, 26
- Terminal Translation Initialization, 11
- Terminating Extension Group (TEG), 11
- Through Dialing, 11
- Time of Day Routing, 11, 26
- Timed Reminder, 11
- Touch-Tone Dialing, 11
- Transfer, 11
- Trunk Group Busy/Warning Indicators to Attendant, 11
- Trunk Identification By Attendant, 11
- Uniform Call Distribution (UCD), 11
- Uniform Dial Plan (UDP), 11, 26
- Unrestricted 5-Digit Uniform Dial Plan, 11

- Vector Directory Number (VDN)
  - Reports, 11
- Voice Message Retrieval, 11, 27
- Voice Terminal Display, 11, 27
- Floor Loading
  - Equipment Room, 103
- Floor Plans and Layouts
  - Equipment Room, 103
- Floor Space
  - Equipment Room, 104
- Forced Entry of Account Codes, 9, 20
- Functional Scheduling Enhancements, 9

## G

- Generalized Route Selection, 9, 20
- Go To Cover, 9
- Grounding
  - Equipment Room, 128

## H

- Hardware and Software
  - Determination, 45
  - Requirements, 12
- Heat Dissipation, 113
- Hold, 9
- Holdover
  - Power, 132
- Hot Line Service, 9
- House Wiring, 133
- How to Use This Document, 4
- Humidity
  - Equipment Room, 111
- Hunting, 9
- Hybrid Line Circuit Pack (TN762), 91

## I

- Inbound Call Management (ICM), 21
- Individual Attendant Access, 9

- Information System Network (ISN)
  - Interface, 9, 21
- Integrated
  - Directory, 9
  - Pooled Modem Circuit Pack (TN758), 91
- Integrated Services Digital Network-
  - Basic Rate Interface (ISDN-BRI), 9, 21
  - Primary Rate Interface (ISDN-PRI), 9, 21
- Intercept Treatment, 10, 21, 22
- Intercom
  - Automatic, 10
  - Dial, 10
- Inter-PBX Attendant Calls, 10, 22
- Intraflow and Interflow, 10, 22
- ISDN-BRI Line
  - TN556, 77

## L

- Last Number Dialed, 10
- Leave Word Calling, 10
- Lighting
  - Equipment Room, 112
- Lightning Protection, 129
- Limits
  - Terminal Equipment, 50
- Line Lockout, 10
- Loudspeaker Paging Access, 10, 22
  - Deluxe, 10, 22

## M

- Main/Satellite Extended Trunk Access, 10
- Malicious Call Trace, 10
- Manual
  - Message Waiting, 10
  - Originating Line Service, 10
  - Signaling, 10
- MET Line Circuit Pack (TN735), 92
- Modem Pooling, 10, 23
- Move Agents From CMS, 10, 23
- M-to-N Digit Conversion, 10, 22

Multi-Appearance Preselection and Preference, 10  
Multiple Listed Directory Numbers, 10  
Multi-User System Management Access, 10  
Music-on-Hold Access, 10, 23

## N

Names Registration, 10, 23  
Network Access  
  Facilities, 73  
  Private, 10, 23  
  Public, 10, 23  
Night Service  
  Hunt Group, 10  
  Night Station Service, 10  
  Trunk Answer From Any Station, 10, 23  
  Trunk Group, 10  
Noise Levels, 113  
Noise Suppression  
  Equipment Room, 112

## O

Off-Premises Station, 10, 23  
Ordering Information, 100  
Outgoing Trunk-to-Outgoing Trunk Transfer, 10

## P

Packet Data Line  
  TN553, 76  
Packet Gateway  
  TN577, 78  
Paging  
  Loudspeaker, 22  
Parameters  
  System, 29  
Partitioning, 14  
PC/PBX Connection, 10  
Personal Central Office Line (PCOL), 10, 23  
Personalized Ringing, 10

Power  
  Failure Transfer, 10, 24  
  Holdover, 132  
  Multi-Carrier Cabinet System, 115  
  Single-Carrier Cabinet System, 118  
Power Requirements  
  -48 Volt DC, 123  
  AC, 115  
  DC, 122  
  UPS, 132  
Power Supply  
  Uninterruptible, 130, 132  
Power System  
  Standby, Multi-Carrier Cabinet, 130  
PPN With Duplication  
  Upgrade To, 136, 139, 147  
PPN Without Duplication  
  Upgrade From System 75 XE, 138  
  Upgrade To, 135, 143, 145  
Printers  
  and Display Terminals, 61  
  System, 63  
Priority Calling, 10  
Privacy  
  Attendant Lockout, 10  
  Manual Exclusion, 10  
Property Management System (PMS), 10, 24  
Protection  
  Lightning, 129  
  Sneak Current, 129

## Q

Queue Status Indication, 10, 24

## R

Recall Signaling, 10  
Recent Change History, 10  
Recorded  
  Announcement, 11, 24  
  Telephone Dictation Access, 11, 25  
Reference Documents, 151



References, 151  
Remote  
  Access, 11, 25  
  Administration, 11, 61  
Report Scheduler, 25  
  and System Printer, 11  
Requirements  
  Air, 111, 112  
  Desktop Space, 110  
  Earthquake Protection, 104  
  Electrical, 112  
  Equipment Room, 103  
  Floor Loading, 103  
  Floor Space, 104  
  Lighting, 112  
  Noise Suppression, 112  
  Temperature and Humidity, 111  
  Wall Space, 110  
Reserve  
  Battery, 132  
Restriction  
  Controlled, 11  
  Miscellaneous Terminal, 11  
  Miscellaneous Trunk, 11  
  Toll/Code, 11  
  Voice Terminal, 11  
Ringback Queuing, 11  
Ringer Cutoff, 25  
Rotary Dialing, 11

## **S**

Send All Calls, 11  
Senderized Operation, 11  
Service Observing, 11, 26  
Single-Digit Dialing and Mixed-Station  
  Numbering, 11  
Sneak Current Protection, 129  
Software  
  and Hardware Determination, 45  
  Feature Additions, 149  
  Requirements, 12  
Speech Synthesizer Circuit Pack (TN725), 92  
Standby Power System, 130

Station Identification/Automatic Number  
  Identification, 11, 26  
Straightforward Outward Completion, 11  
Subnet Trunking, 11, 26  
System  
  Data Terminals, 62  
  Measurements, 11  
  Parameters, 29  
  Printers, 11, 25, 63  
  Reload Indication, 11  
  Status Report, 11  
  Version Determination, 43

## **T**

Temperature  
  Equipment Room, 111  
Temporary Bridged Appearance, 11  
Ten Digit-to-Seven Digit Conversion, 11, 26  
Terminal  
  Equipment, 45  
  Equipment Limits, 50  
Terminal Translation Initialization, 11  
Terminals and Printers, 61  
Terminating Extension Group (TEG), 11  
Through Dialing, 11  
Tie Trunk Circuit Pack (TN760), 92  
Time of Day Routing, 11, 26  
Timed Reminder, 11  
Tone Clock Circuit Pack (TN741 or TN768), 93  
Tone Clock Circuit Pack (TN780), 93  
Tone Detector Circuit Pack (TN748), 93  
Touch-Tone Dialing, 11  
Traffic Considerations, 72  
Transfer, 11  
Trunk Group Busy/Warning Indicators to  
  Attendant, 11  
Trunk Identification By Attendant, 11

**U**

Uniform Call Distribution (UCD), 11  
Uniform Dial Plan (UDP), 11, 26  
Uninterruptible Power Supply (UPS), 130, 132  
Unrestricted 5-Digit Uniform Dial Plan, 11  
Upgrades  
    Attendant Console Replacement, 141  
    General, 135  
    To EPN, 137  
    To EPN With Duplication, 144, 146  
    To EPN Without Duplication, 143  
    To PPN With Duplication, 136, 139, 147  
    To PPN Without Duplication, 135, 138,  
        143, 145  
Users and Required Equipment, 46

**V**

Vector Directory Number (VDN) Reports, 11  
Version Determination  
    System, 43  
Voice Message Retrieval, 11, 27

## Voice Terminal

    Additions, 149  
    Compatibility, 49  
    Display, 11  
    Quantities, 47  
Voice Terminal Display, 27  
Voice/Data Terminal  
    Equipment Assignments, 45  
    Quantities, 47  
    Totals, 45

**W**

Wall Space Requirements  
    Equipment Room, 110  
Wiring  
    House, 133