



TPU250

Telephone Paging Amplifier

Installation and Use Manual

Notice

Every effort was made to ensure that the information in this guide was complete and accurate at the time of printing. However, information is subject to change.

Important Safety Information

Always follow these basic safety precautions when installing and using the unit:

1. Read and understand all instructions.
2. Follow all warnings and instructions marked on the product.
3. DO NOT block or cover the ventilation slots and openings. They prevent the product from overheating. DO NOT place the product in a separate enclosure or cabinet, unless proper ventilation is provided.
4. Never spill liquid on the product or drop objects into the ventilation slots and openings. Doing so may result in serious damage to the components.
5. Repair or service must be performed by a factory authorized repair facility.
6. The product is provided with a UL-CSA approved, 3-wire ground type plug. This is a safety feature. DO NOT defeat the safety purpose of the grounding type plug. DO NOT staple or otherwise attach the AC power supply cord to building surfaces.
7. DO NOT use the product near water or in a wet or damp place (such as a wet basement).
8. DO NOT use extension cords. The product must be installed within 6 feet of a grounded outlet receptacle.
9. DO NOT install telephone wiring during a lightning storm.
10. DO NOT install telephone jacks in a wet location unless the jack is specifically designed for wet locations.
11. Never touch uninsulated wires or terminals, unless the line has been disconnected at the paging or controller interface.
12. Use caution when installing or modifying paging or control lines.

Applications Assistance

Our Applications Engineering Department is available to assist you from 8:30 A.M. to 6:00 P.M. and on call until 8:00 P.M., Eastern Daylight Time, Monday through Friday.
Call 800-999-2809, Option 2.

Domestic and International Listings

UL and CSA Listed.

Contents

	Page
INTRODUCTION	4
PACKAGE CONTENTS	4
INSTALLATION	5
Mounting	5
<i>Wall Mounting</i>	5
<i>Rack Mounting</i>	5
WIRING CONNECTIONS	6
Input Wiring	6
<i>Tel Input</i>	6
<i>Music Input</i>	7
<i>Microphone Input</i>	7
<i>Night Ringer Connections</i>	8
<i>Bridging Inputs</i>	8
<i>Input Cover Replacement</i>	8
Output Wiring	9
<i>Speaker Connection</i>	9
<i>Additional Power Amplifier</i>	10
<i>Line-Matching Transformer WMT1A Connector</i>	10
<i>Output Cover Replacement</i>	10
OPERATION	11
Indicators	11
Controls	11-12

Telephone Paging Amplifier

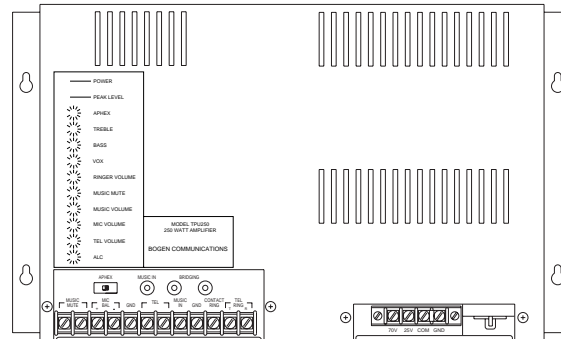

Figure 1: Telephone Paging Amplifier

Introduction

This document describes the Bogen TPU250 250-watt Telephone Paging Amplifier (see Figure1). This is a full-featured, wall-mounted amplifier that provides inputs for dry loop 600-ohm telephone page signal, background music source, and low impedance microphone. Automatic music mute is provided when making a telephone page. Background music mute level during a page is adjustable and the music slowly fades back in after the page is completed. An automatic level control system limits the output level of the telephone page channel so that differences in the volume of the paging party's voice will be less noticeable. Bass and treble controls are provided for adjusting the quality of the output signal. An Aphex® Aural Exciter feature is also provided. Aphex improves the clarity of the output signal by replacing the higher frequency harmonics that are normally lost through the telephone system. This amplifier includes a built-in night ringer that can be triggered by either a standard telephone (analog) ring signal or an external contact closure. The night ringer mutes the background music, but not pages.

Package Contents

- * Telephone Paging Amplifier unit
- * 4 wall-mounting screws
- * Installation and Use Manual

Before You Start Review the contents of the box. Read through this entire manual to understand how this product installs and operates.

Figure 2: Wall Mounting the Amplifier

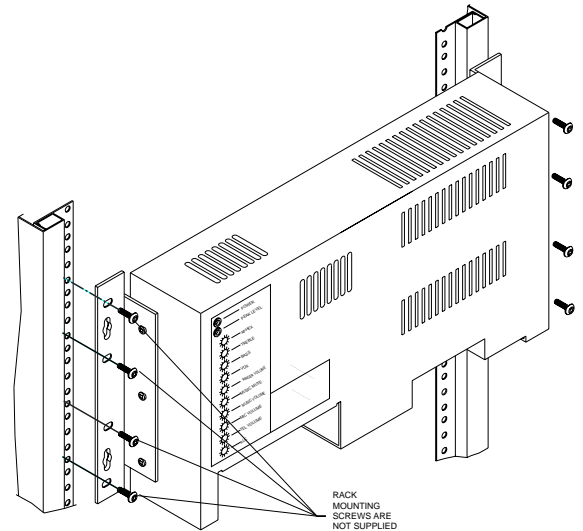
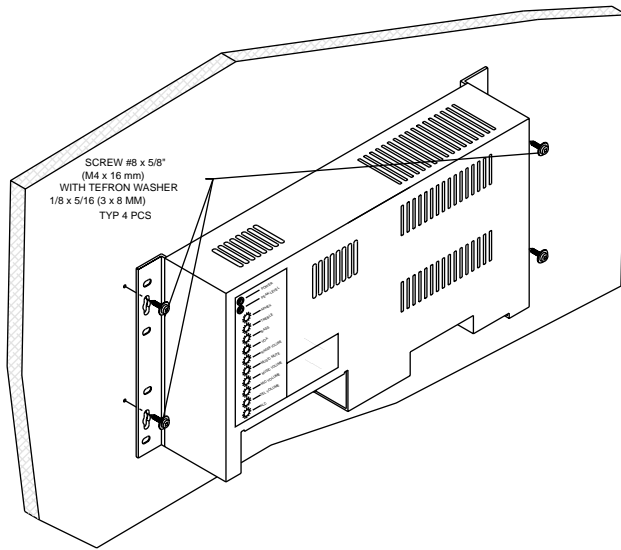

Figure 3: Rack Mounting the Amplifier

Installation

Mounting

The amplifier is designed for wall mount applications but can also be mounted in a standard 19" rack. The TPU250 amplifier weighs 31 lbs.

NOTE: The amplifier will produce heat during operation which will rise and may cause problems for temperature-sensitive equipment mounted above it. Mount the amplifier near the top of the backboard (for wall mounting) or rack (for rack mounting) so that no other equipment will be above it. If this is not possible, then allow at least 12" between the top of the amplifier and the bottom of any equipment positioned above it. Also allow at least 6" between the bottom of the amplifier and any equipment below it to allow for adequate air circulation.

Wall Mounting

To wall mount this unit, use the four 5/8" pan head screws with nylon washers provided (see Figure 2). Insert the top two screws first leaving the heads protruding about 1/4". Lift the amplifier and place it over the 2 screws using the top keyhole slots in the flanges at the sides of the amplifier. Allow the amplifier to rest on the 2 screws and then proceed to insert the bottom 2 screws into the lower keyhole slots. With all the screws in place, tighten the screws to secure the amplifier.

NOTE: Backboard must be a minimum of 3/8" thick plywood and securely mounted to the wall.

Rack Mounting

The amplifier was designed to mount directly to standard 19" racks using the mounting flanges as shown in Figure 3 (rack screws are not supplied). In the factory set position, the unit will protrude from the front of the rack. This provides the best ventilation of the unit and easier access to the wiring connections.

NOTE: The unit can also be mounted partially recessed in the rack by reversing the mounting flanges. Unscrew the mounting flanges (3 screws mount the flange to the cover) and install them in a flipped over orientation. This position will provide adequate ventilation and centers the weight of the unit over the rack rails.

Wiring Connections

IMPORTANT: Before making any connections or wiring changes to the amplifier or any equipment connected to the amplifier, make sure that the amplifier is NOT plugged into an AC outlet.

NOTE: The amplifier does not have a power switch, so it must be unplugged in order to turn the power off.

Input Wiring

All signal input and control wiring is made to the terminal strip and RCA connectors beneath the left side access cover. Loosen the 2 Phillips-head screws on each side of the cover and remove it.

TEL Input The telephone input is a 600-ohm, dry loop, balanced input available at the T and R terminals. Automatic music mute is provided when making a telephone page.

Figure 4: Wiring for TEL Input

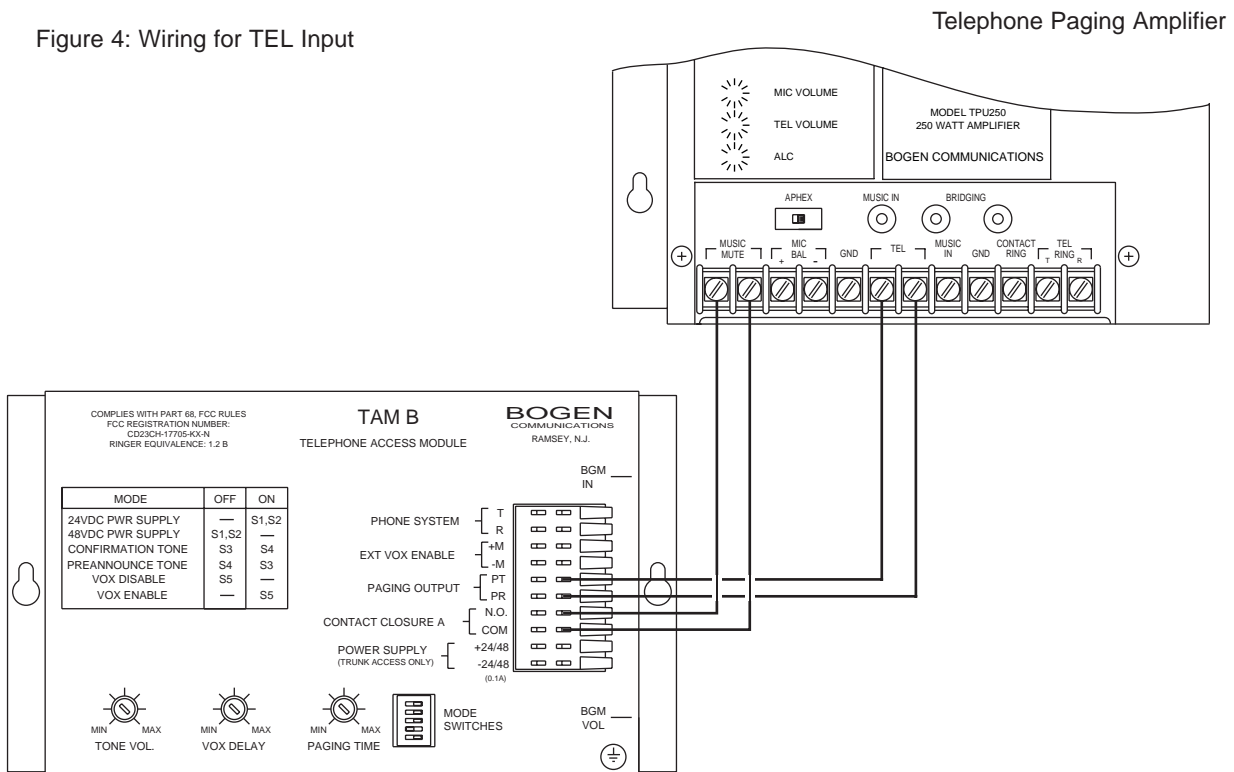

Music Input

A single RCA connector and screw terminals are provided for the connection of a background music source. The music input is a mono unbalanced input, so the music source's output should be unbalanced and mono. If a balanced input is needed, use a Bogen Line-Matching Transformer WMT1A (sold separately) to balance the music input. The WMT1A is also effective in breaking ground loops that cause hum.

Microphone Input

A high gain, low impedance microphone input is provided in this amplifier. It is designed to work with microphones like Bogen's MBS1000 microphone. Connect the microphone's black wire to the amplifier's "-" (negative) terminal under the MIC BAL connections. Connect the microphone's Red wire to the "+" (positive) terminal. Connect the shield wire from the microphone to the adjacent GND terminal.

Two conductor shielded microphone wire should be used to extend the cable from the microphone. 22 AWG shielded, twisted pair speaker cable will also work. When extending microphone cable, be sure to connect the shields of the microphone cable to the extension wire.

Figure 5: Connect Microphone to Telephone Paging Amplifier

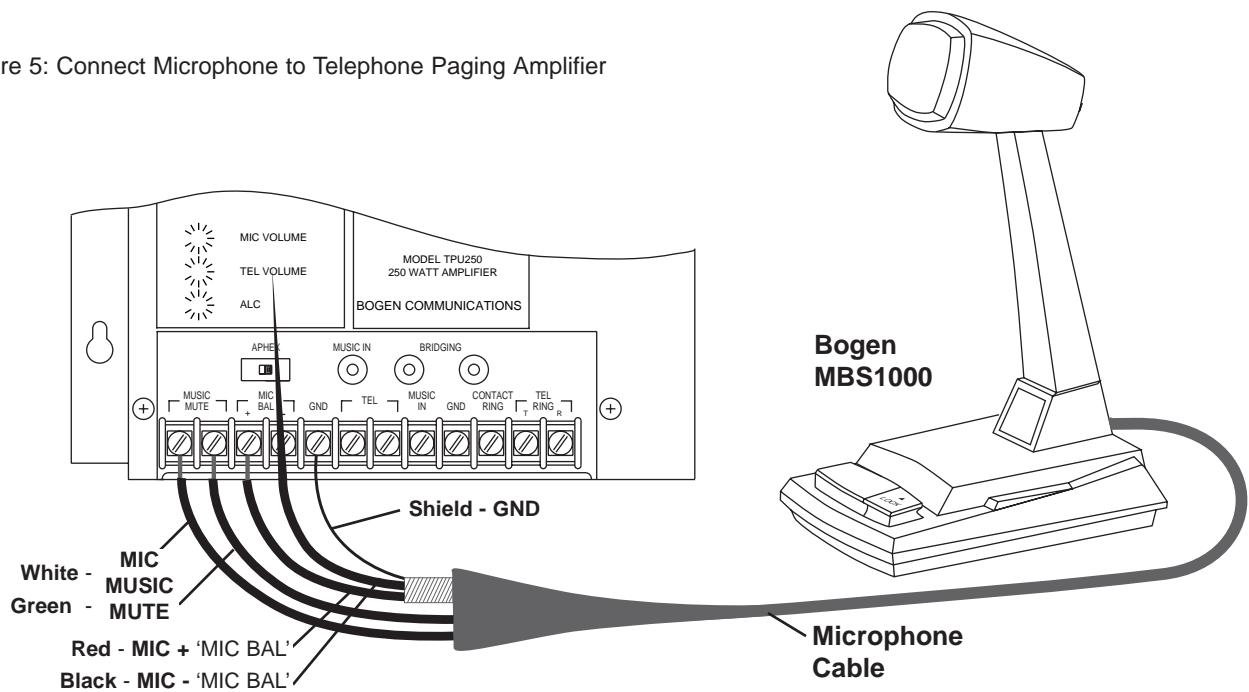

Night Ringer Connection

Either a standard telephone (analog) ring signal (90 - 105 V AC, 20 - 30 Hz) or an external contact closure activates the night ringer function of the amplifier. To activate the night ringer using standard telephone (analog) ring, connect the analog station's tip lead to the TEL RING "T" terminal and connect the ring lead to the "R" terminal. If using an external contact closure, connect the closure pair across the CONTACT RING terminals (not polarized). The night ringer follows the cadence of the activating signal.

Bridging Inputs

Bridging permits two amplifiers to be used in tandem with one another to increase the total output power of the system, thereby permitting additional speakers to be added (see Figure 6). For example, when two 250-watt amplifiers are bridged, the total output capacity of the system is 500 watts. However, bridging does not increase the size of the load a TPU250 can individually handle. Once bridged, each amplifier will amplify the inputs present on both amplifiers. The level control of a particular input on an amplifier will control the volume of this signal on both amplifiers. The cable used to bridge amplifiers should not exceed 20 feet in length.

NOTE: You cannot bridge more than two TPU250 amplifiers at one time. TPU250 amplifiers can only be bridged with other TPU250 amplifiers.

Input Cover Replacement

When all connections are made, remove an appropriate knockout on the input cover. Replace the cover and tighten the screws while dressing the wires through the knockout hole.

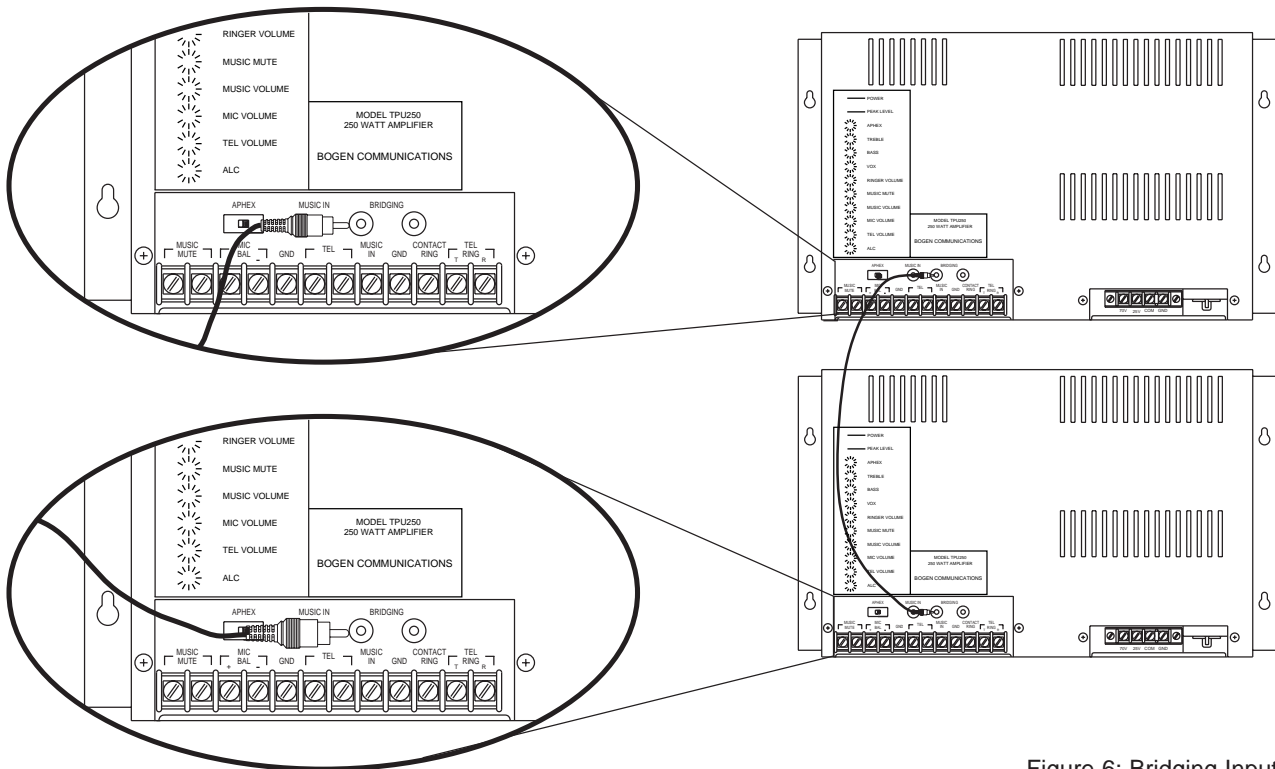

Figure 6: Bridging Inputs

Output Wiring

All output wiring connections are made to the terminal strip located under the right side access panel. Loosen the 2 Phillips-head screws on each side of the cover and remove the cover.

IMPORTANT: Before making any connections or wiring changes to the amplifier or any equipment connected to the amplifier, make sure that the amplifier is NOT plugged into an AC outlet.

NOTE: The amplifier does not have a power switch, so it must be unplugged in order to turn the power off.

Speaker Connection

70-volt speaker connections are made between the 70V and COM terminals on the output terminal strip (see Figure 7). Use a 22 AWG shielded, twisted pair cable. Connect the shield of the cable to the GND terminal of the output terminal strip. The COM and GND terminals of the output terminal strip are connected using a shorting clip. The shorting clip enables the amplifier output to act as an unbalanced output (one side of the output connected to ground). If desired, the output can be made to be a balanced output with no connection to ground. To balance the output, simply remove the shorting clip. All speaker connections remain the same as above including connecting the shield to the GND terminal.

NOTE: The amplifier output terminal strip includes a terminal for 25V speaker connections. This is provided for special applications and is generally not used.

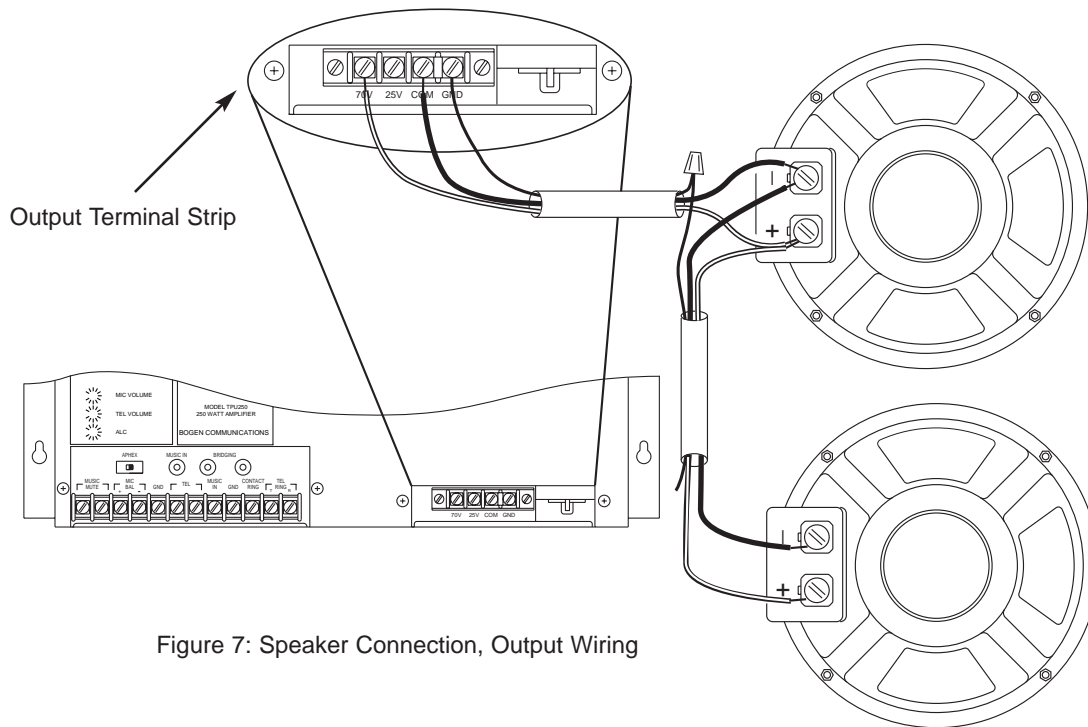

Figure 7: Speaker Connection, Output Wiring

Additional Power Amplifier

An external power amplifier can be used with the TPU250 amplifier. You must first add a resistor voltage divider to the telephone amplifier, as illustrated in Figure 8. Connect a patch cord to the high-level/high-impedance input of the booster amplifier.

Figure 8 : Output Circuitry

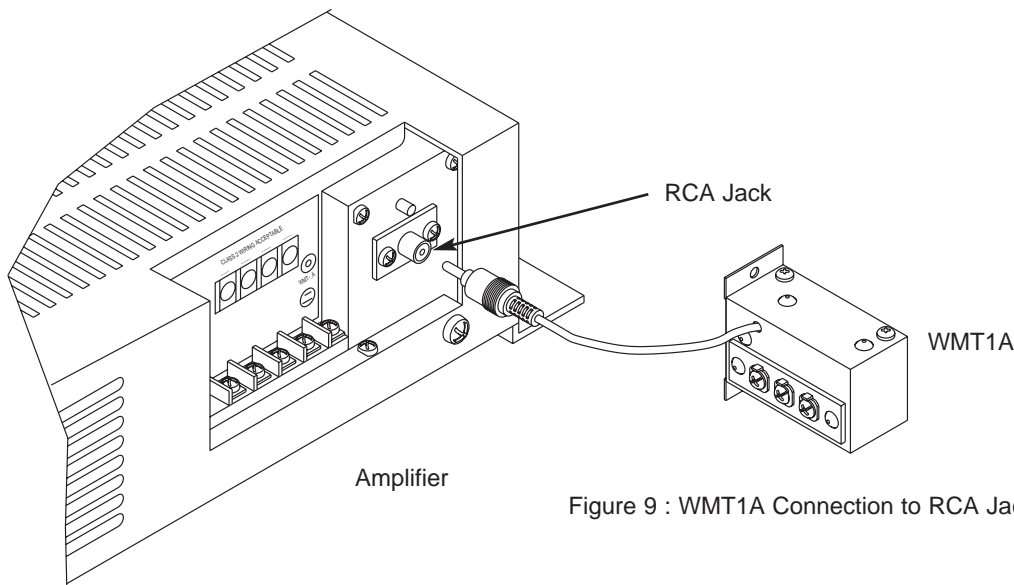
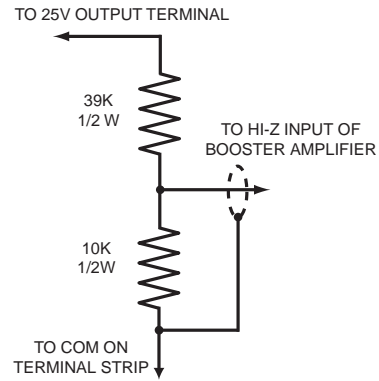

Figure 9 : WMT1A Connection to RCA Jack on Amplifier

**Line-Matching Transformer
WMT1A Connector**

An RCA jack is provided near the output terminal strip for connection to a WMT1A line-matching transformer. A 600-ohm, balanced telephone level output signal can be obtained by plugging the RCA connector of the WMT1A line-matching transformer into this jack and taking the output signal off of the WMT1A line-matching transformer screw terminals (see Figure 9). This is useful for dividing a long line when connecting to remote equipment.

Output Cover Replacement

When all output connections are made, remove the appropriate knockout on the input cover. Replace the cover and tighten the screws while dressing the wires through the knockout hole.

Operation

IMPORTANT: Before plugging the amplifier into an AC outlet, turn all volume controls to their full counterclockwise positions.

Indicators

- POWER IND** The POWER IND LED illuminates whenever AC power is applied to the amplifier (there is no power switch on the amplifier).
- PEAK LEVEL** The PEAK LEVEL LED illuminates whenever the speaker output signal level approaches its maximum level. This indicator is used when setting volume levels. Maximum output level is achieved when the PEAK LEVEL indicator flashes intermittently on loud peaks of the input signal. If the indicator illuminates steadily, the output signal volume is set too high and distortion is occurring. Decrease the volume control for the appropriate input until the indicator flashes only occasionally.

Controls

- TEL VOLUME** This control adjusts the level of the telephone page output. Further adjustment can be made using the PEAK LEVEL indicator described above.
- MUSIC VOLUME** This control adjusts the level of the background music output. The background music level should be set to an acceptable level without overdriving the system. When adjusting this level, the PEAK LEVEL indicator should be observed to ensure that the amplifier signal is not distorted.
- MUSIC MUTE** This control adjusts the level of the background music heard during a paging announcement. The background music mute level should be set to the customer's satisfaction, but the page announcement must always be easily heard above the background music.
- MIC VOLUME** This control adjusts the level of the microphone page output.
- CAUTION:** Microphone should not be placed near any paging loudspeakers.
- RINGER VOLUME** This control adjusts the level of the night ringer tone output. The background music level should be set to the customer's satisfaction. When adjusting this level, the PEAK LEVEL indicator should be used to ensure that the amplifier signal is not distorted.
- APHEX** This control adjusts the amount of Aphex® Aural Exciter effect mixed in to the page signal. To use this function, the APHEX switch beneath the input connection cover must be set to ON. Setting this switch to OFF bypasses the Aphex effect and makes the control inoperable. With the APHEX switch turned on, make a page and rotate the control until the audio sounds crisp and clear.

BASS and TREBLE

Bass and treble controls are provided to adjust the high frequency and low frequency response of the paging system. Reference positions are provided for these controls. When set to these positions, the frequency response of the system will be flat. Set the controls to the customer's satisfaction. Clockwise rotation increases (boosts) the response and counterclockwise reduces (cuts) the response. Increasing bass and/or treble can cause output signal peaks to increase. Check the PEAK LEVEL indicator after making bass adjustment and lower the music input volume if excess peaking occurs.

VOX (Voice Operated) SENS

The VOX SENSitivity control should be set so that only the desired signal is above the threshold level, while noise or unwanted signal is below it. When an input signal (such as voice) is detected, the music channel will be muted. To adjust the sensitivity of this circuit:

1) Rotate the control fully clockwise. While making a page announcement and talking at a low level, the sound should not be choppy nor missing parts of words. If it is choppy, or if intelligibility is poor, rotate the control counterclockwise to the point where the sound is clear and crisp (but not to the maximum counterclockwise position).

2) If the background music shuts down when no page is in progress, rotate the control clockwise until the music is restored.

ALC

The ALC controls the level at which the amplifier will begin to limit the output signal level.

Manual Output Adjustment Procedure (follow only if minor adjustments to the reference settings are not adequate)

1) Disable ALC by turning ALC control to the maximum counterclockwise position.

2) Make a page, speaking softly, yet distinctly. Set the TEL VOLUME control to the desired paging level during this page.

3) Make another page speaking relatively loudly this time. Rotate the ALC control clockwise, while making the page, until it has the same loudness as the first page.

NOTE: The TEL Volume and ALC controls work together to set the output level.

NOTE: The PEAK LEVEL indicator should not show excessive peaking during loud pages. If this is occurring, the ALC control must be further increased.