

Telex[®] Technical Data

Model PT-400 Switch Kit

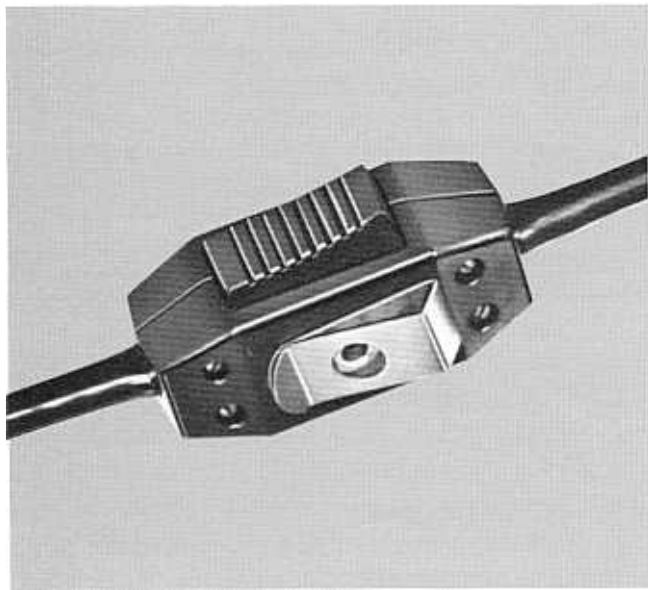

General Description

The Telex PT-400 Switch Kit connects in-line in the cordage of a headset or microphone. It may be wired to provide a variety of functions such as push-to-talk, push-to-cough or relay keying when used with Ham, CB and other communications equipment.

The kit contains either one or two SPDT Type, Form C, microswitches rated at 10 amps, 125/250 VDC. The switches are positively mounted over two spring pins inside the high impact plastic housings. Two vinyl strain/bend reliefs along with two metal retainers hold cordages up to .180" (4.6 mm) in diameter firmly in place. The high impact plastic pushbutton can activate the switches to either a momentary or a locked "on" position. A clothing/belt clip is firmly attached to one of the housing halves. The clip can be rotated 360° to locate the switch assembly in any convenient position.

Assembly Procedure

(Refer to detail on reverse side)

Tools required are a Phillips screwdriver, pliers, side cutter, soldering iron, solder.

- Determine exactly where the switch is to be located and cut the cord.
- Disassemble the PT-400 Switch Kit by removing the four (4) #2-28 x 1/2" Phillips machine screws.
- Slide one vinyl strain relief over each end of the cut cordage with the flange towards the eventual switch location.
- Determine leads to be switched and spliced and strip to desired length.
- Solder leads to appropriate switch contacts.
- Solder leads that require splicing. Unused switch contacts may be used for this purpose. Make sure that all loose splices are carefully insulated from each other and from the switch contacts.
- Position housing with spring pins on a table, pins up. Slide both switches over the pins until they rest on the plastic tabs in the housing. Determine the position the vinyl strain reliefs should have on the cordage to be properly located in the housing. Position the metal retainers between each strain relief and the switches. Remove the switches and crimp both metal retainers over the cordage. Reposition the switches, cordage, and strain reliefs in the housing. Exercise caution not to pinch any leads between the switches or between the switches and the housing.
- Position the pushbutton.
- Position remaining housing half and assemble with the 4 machine screws. Again, exercise caution not to pinch leads between the switches and the housing.

© Telex Communications, Inc.: May 1995

TELEX[®]

Specifications subject to change without notice.

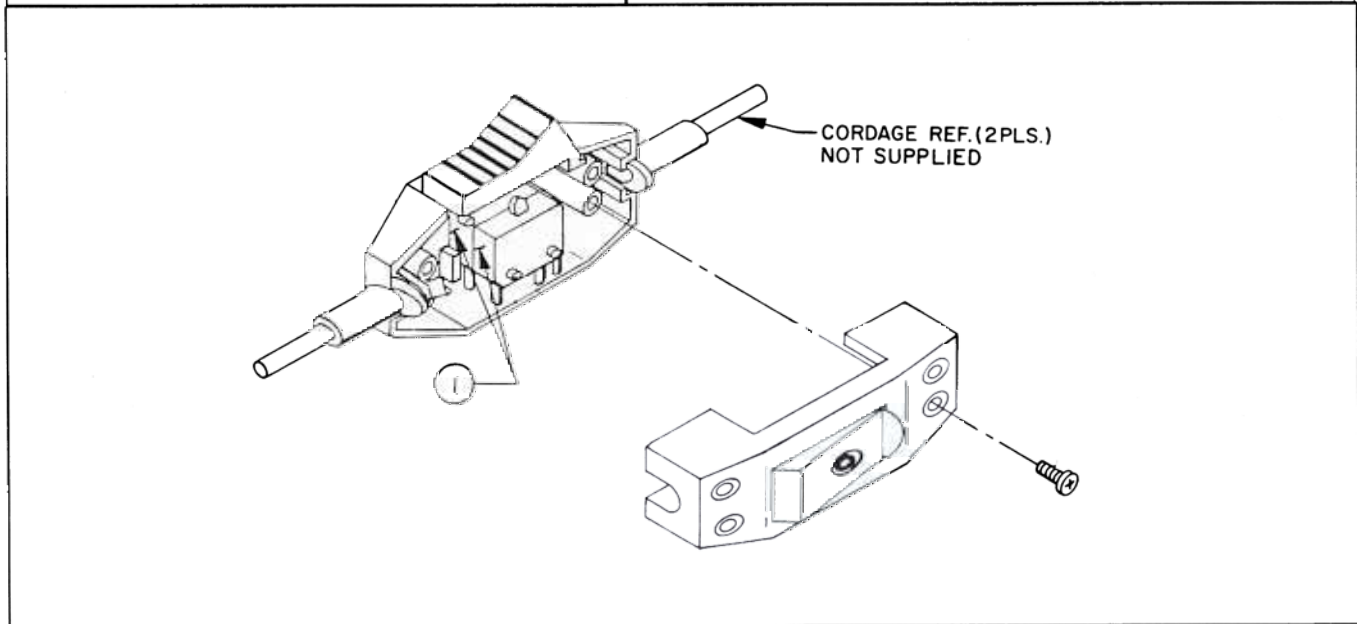
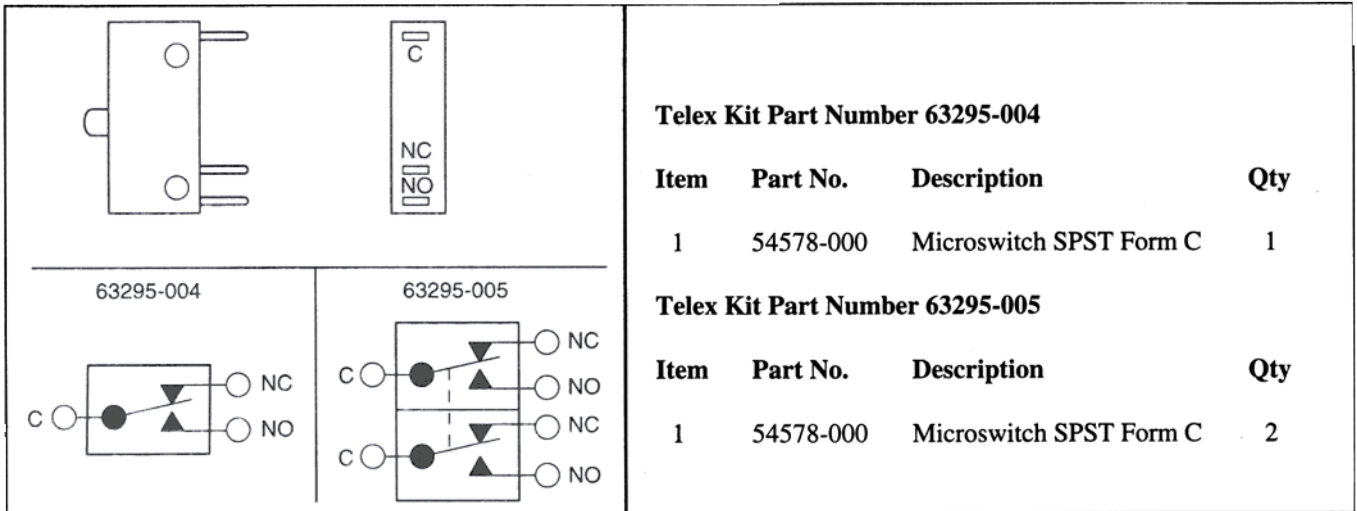

Exploded Isometric Diagram

Specifications

Switch Type: SPDT, Form C. Solder Terminals
Voltage: 125/250 VDC maximum
Current: 10 amps

Color: Black
Cordage: Can be used with up to .180" (4.6 mm) diameter
Weight: 2.5 oz (72 grams)

Ordering Information

Model PT-400 Switch Kit

· Catalog No. 63295-004
 · Catalog No. 63295-005

