

Quick Start Guide Control I/O



To download the latest version of SymNet Designer, the Windows application that controls all SymNet hardware, go to: www.symmetrixaudio.com

Before You Begin

1/11

What Ships in the Box

- A Control I/O hardware device.
- One PS-5 switching power supply which provides 15 volts DC @ 1.33 amperes. NOTE: The PS-5 will accept a 100-240 VAC input. A power cable for domestic use is supplied for the PS-5. Export customers should supply the appropriate substitute cable for their locale.
- This Quick Start Guide.
- An RJ-45 Incompatibility Warning sheet.

What You Need to Provide

- A Windows PC with 300MHz or higher Pentium and:
 - WIN 98SE, ME, 2000 or XP.
 - 10-15 MB free storage space.
 - 1024x768 graphics capability.
 - 16-bit or higher colors.
 - CD-ROM drive or Internet connection.
 - 64MB RAM (WIN 98SE/ME), 128MB RAM (WIN 2000/XP).
- Shielded twisted pair wire to connect the Control I/O RS-485 port to the RS-485 port of a master SymNet DSP™ or CobraLink™ unit.
- CAT-5 cables to connect the Control I/O to any ARC(s).
- External controls (pots, switches, encoders, etc.) and hook up wire as necessary.

Getting Help

SymNet Designer, the Windows application that controls all SymNet hardware, includes a help module which acts as a complete user's guide for both hardware (including the Control I/O) and software. A printable copy is also available at www.symmetrixaudio.com.

If you have questions beyond the scope of the help module, contact our Customer Support Group in the following ways:

Tel (425) 778-7728
8:00 am to 4:30 pm
Monday through Friday,
Pacific Time

Email tech@symmetrixaudio.com

Web www.symmetrixaudio.com

This device complies with part 15 of the FCC Rules. Operation is subject to the following two conditions: (1) This device may not cause harmful interference, and (2) this device must accept any interference received, including interference that may cause undesired operation.

This Class B Digital apparatus meets all requirements of the Canadian Interference-Causing Equipment Regulations
Cet appareil numérique de la classe B respecte toutes les Exigences du Règlement sur le matériel brouilleur du Canada.

Important Safety Instructions.

1. Read these instructions.
2. Keep these instructions.
3. Heed all warnings.
4. Follow all instructions.
5. Do not use this apparatus near water.
6. Clean only with dry cloth.
7. Do not block any ventilation openings. Install only in accordance with the manufacturer's instructions.
8. Do not install near any heat sources such as radiators, heat registers, stoves, or other apparatus (including amplifiers) that produce heat.
9. Do not defeat the safety purpose of the polarized or grounding-type plug. A polarized plug has two blades with one wider than the other. A grounding type plug has two blades and a third grounding prong. The wide blade or the third prong are provided for your safety. If the provided plug does not fit into your outlet, consult an electrician for replacement of the obsolete outlet.
10. Protect the power cord from being walked on or pinched particularly at plugs, convenience receptacles, and the point where they exit from the apparatus.
11. Only use attachments/accessories specified by the manufacturer.
12. Use only with the cart, stand, tripod, bracket, or table specified by the manufacturer, or sold with the apparatus. When a cart is used, use caution when moving the cart/apparatus combination to avoid injury from tip-over.
13. Unplug this apparatus during lightning storms or when unused for long periods of time.
14. Refer all servicing to qualified service personnel. Servicing is required when the apparatus has been damaged in any way, such as power-supply cord or plug cord is damaged, liquid has been spilled or objects have fallen into the apparatus, the apparatus has been exposed to rain or moisture, does not operate normally, or has been dropped.



WARNING: TO REDUCE THE RISK OF FIRE OR ELECTRIC SHOCK DO NOT EXPOSE THIS EQUIPMENT TO RAIN OR MOISTURE

AVIS: RISQUE DE CHOC ELECTRIQUE NE PAS OUVRIR

SEE OWNERS MANUAL. VOIR CAHIER D'INSTRUCTIONS.
No user serviceable parts inside. Refer servicing to qualified service personnel.
Il ne se trouve a l'interieur aucune piece pouvant etre repareré l'usager.
S'adresser a un reparateur competent.

The lightning flash with arrowhead symbol within an equilateral triangle is intended to alert the user of the presence of uninsulated "dangerous voltage" within the product's enclosure that may be of sufficient magnitude to constitute a risk of electric shock to persons. The exclamation point within an equilateral triangle is intended to alert the user of the presence of important operating and maintenance (servicing) instructions in the literature accompanying the product (i.e. this Quick Start Guide).

CAUTION To prevent electric shock, do not use the polarized plug supplied with the unit with any extension cord, receptacle, or other outlet unless the prongs can be fully inserted.

Power Source. SymNet™ Control I/O hardware uses a switching power supply that automatically adjusts to the applied voltage. Ensure that your AC mains voltage is somewhere between 100-240 VAC, 50-60 Hz. Use only the power cord and connector specified for the product and your operating locale. A protective ground connection, by way of the grounding conductor in the power cord, is essential for safe operation.

User Serviceable Parts. There are no user serviceable parts inside the SymNet™ Control I/O. In case of failure, customers inside the U.S. should refer all servicing to the Symetrix factory. Customers outside the U.S. should refer all servicing to an authorized Symetrix distributor. Distributor contact information is available online at www.symmetrixaudio.com.

Quick Start Guide

Control I/O



To download the latest version of SymNet Designer, the Windows application that controls all SymNet hardware, go to: www.symnetriaudio.com

Overview, Front Panel, Rear Panel, System Connection 2/11

Overview

The Control I/O is a 1 rack space SymNet system accessory which expands the SymNet's ability to control and be controlled from external devices. Oftentimes, system designs require more control options than provided on one or more of the core SymNet DSP devices. The Control I/O serves to expand and augment a SymNet system's capabilities. Additionally, Control I/O provides a MIDI gateway to SymNet allowing the use of low-cost generic MIDI controllers for control of almost any SymNet DSP parameter. The Control I/O also provides a generic ASCII command protocol which allows it to be used in a stand-alone fashion or integrated into other RS-485 compatible control systems such as those made by AMX or Crestron.

Front Panel

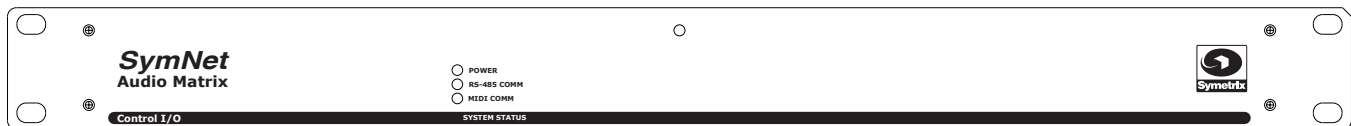

| Item | Description | What It Does |
|-------------|-------------|---|
| POWER | Red LED | Indicates that the unit is powered on. |
| RS-485 COMM | Yellow LED | Indicates active RS-485 communications. |
| MIDI COMM | Green LED | Indicates active MIDI communications. |

Rear Panel

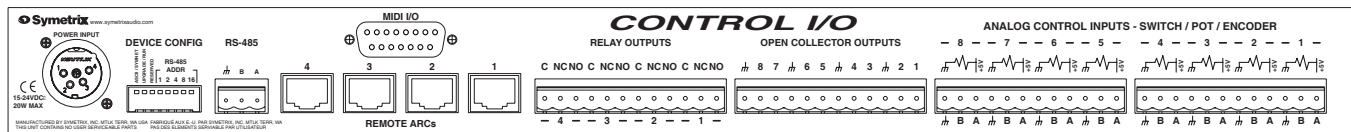

| Item | Description | What It Does |
|------------------------|--------------------|--|
| POWER INPUT | 4 pin XLR jack | Accepts power from a Symetrix PS-5 switching power supply (15 VDC @ 1.33 A). |
| DEVICE CONFIG | 8 DIP switch block | Configures the Control I/O's device address (0-31). Addressing is done in a binary fashion. (See Device Address Quick Reference). |
| RS-485 | Euroblock | Connects to Ring Master SymNet hardware device (SymNet 8x8, 8in or 8out DSP, or SymNet CobraLink if multi-ring system) or 3rd party RS-485 compatible controller. |
| MIDI I/O | Female DB15 | Allows external MIDI control via a standard DB15 "joystick" to (2) DIN 5 MIDI IN and MIDI OUT cables adapter. (Adapter not included). |
| REMOTE ARCs | 4 x RJ-45 | Distributes power and RS-485 data to one or more ARCs per port. (See ARC Network Design) |
| RELAY OUTPUTS | Euroblocks | 4 x SPDT relays rated at 3A, 24VDC, resistive; 0.3A, 60VDC, resistive and can be wired normally open or normally closed. |
| OPEN COLLECTOR OUTPUTS | Euroblocks | 8 x open collector outputs with paired common ground pins. OC outputs go low (0V) when active, and are internally pulled high (5V) when inactive and can drive external LED indicators directly. |
| ANALOG CONTROL INPUTS | Euroblocks | 8 x analog control inputs able to be used as 8 potentiometer inputs, 8 mechanical rotary encoder inputs, or as 16 switch inputs (+5 VDC reference voltage supplied). |

Control I/O connections to SymNet system

The Control I/O connects to any Ring Master SymNet hardware device. This would be any CobraLink device in the system or the 8x8, 8in, 8out or DigIO DSP device at address 1. The Control I/O connects via the RS-485 ports using shielded twisted pair cable wired in parallel.

Warning! DO NOT plug the RJ-45 connectors labeled "REMOTE ARCs" into any RJ-45 connector labeled "SYMLINK", "HOMERLINK" or "ETHERNET".

Quick Start Guide

Control I/O

To download the latest version of SymNet Designer, the Windows application that controls all SymNet hardware, go to: www.symetrixaudio.com

Analog Control Input and Open Collector Output Wiring

Analog Control Input Wiring

The following illustrations show the connection of either a 10k ohm linear potentiometer, a mechanical rotary encoder or switches to one of the 8 analog control inputs of Control I/O. (Please see the SymNet Designer online help for information on how to assign an analog control input to a SymNet DSP parameter.)

Typical Control Potentiometer Wiring

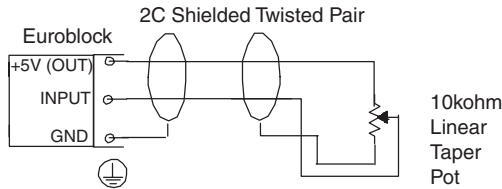

Typical Control Switch Wiring for Discrete Switch Inputs

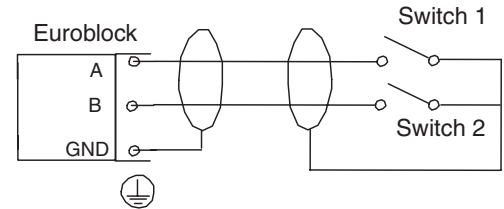

Typical Mechanical Rotary Encoder Wiring

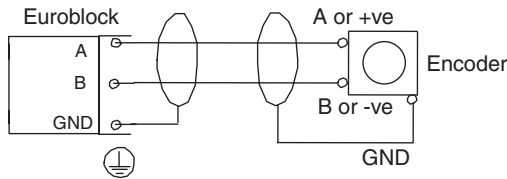

The Symetrix model RC-3 is the perfect potentiometer match for the Control I/O. Suitable potentiometers, switches and encoders might also be sourced from electronic parts suppliers such as Digi-key. Note that encoders must be of the mechanical type.

Disclaimer: From time to time we test the compatibility of our own products with those of third parties. While we are happy to share with our customers the results of our own studies as well as other possibly unsubstantiated information regarding these third party products, it is the policy of Symetrix, Inc. to neither endorse, recommend nor support products manufactured and/or supplied by third parties. The responsibility of choosing third party products which are compatible with Symetrix products rests solely with the qualified contractor, consultant or system designer.

Open Collector Output Wiring

The following illustrations depict three typical open collector output hook ups. The most common uses for the open collector outputs are to fire external LED indicators (LED lit when OC inactive) or drive external relays. (Please see the SymNet Designer online help for information on how to address an Open Collector output in a SymNet DSP design.)

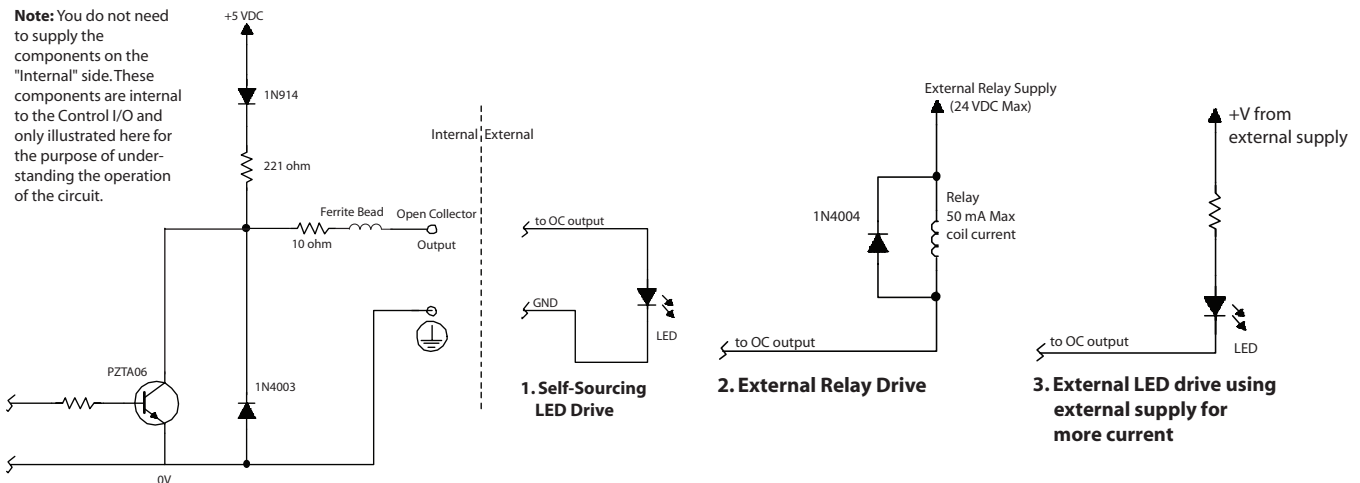

Relay Outputs, Remote ARCs, ARC Network Design 4/11

Relay Outputs

The Control I/O provides four (4) SPDT relay contacts. Common, Normally Closed and Normally Open pins are furnished on Euroblock connectors. Contact ratings for the relays are: 3A, 24VDC, resistive; 0.3A, 60VDC, resistive. **Do not use at 120 VAC.** (Please see the SymNet Designer online help for information on how to address a Relay Output in a SymNet DSP design.)

Remote ARCs

The four (4) REMOTE ARC ports distribute power and RS-485 data to one or more ARCs arranged in one or more chains over standard CAT-5 cable. The Control I/O can support up to eight (8) ARCs total within the guidelines set forth in the **ARC Network Design** section. (Please see the SymNet Designer online help for information on how to program the ARC.)



Warning! The RJ-45 connectors labeled “REMOTE ARCs” are only for use with the ARC controllers. Do not plug these connections into any SymLink, HomerLink or Ethernet connector or into an ARC-PS or even another Control I/O!

ARC Network Design

The ARC’s power requirements vary depending on the voltage supplied to it. At 15V DC, it uses approximately 115 mA, while at 6V DC it uses approximately 300 mA maximum. As the voltage goes from 15V DC to 6V DC, the current requirement increases accordingly.

ARCs can be daisy-chained and fed power over this daisy-chain from the Control I/O. However, as the length of the cable increases, so does the resistive line loss, which lowers the voltage available at each subsequent ARC. The actual power drain on each output from the Control I/O can vary substantially depending on the number of ARCs and the distance each of them is separated by. In order to assist with system design, Symetrix has available a Microsoft Excel spreadsheet that can help a system designer determine power requirements based upon cable length, number of ARCs and the power supply to be used. This spreadsheet can be downloaded from the SymNet Technical Support pages at:

http://www.symmetrixaudio.com/SymNet_Web/index.htm

The following table gives some indication of cabling limitations, based on DC power only (the table is not relevant if only RS-485 is distributed via the Control I/O): minimum stated distances assume 28 gauge CAT-5 cabling, maximum stated distances assume 24 gauge CAT-5 cabling.

| CABLE LENGTH LIMITATIONS FOR ARC DC POWER OVER CAT-5 CABLE | |
|--|---------------------------------|
| Total cable length (to end of chain) | Number of ARCs in 1 daisy chain |
| 224-640 ft. | 4 |
| 276-792 ft. | 3 |
| 350-1028 ft. | 2 |
| 486-1396 ft. | 1 |

If power is not distributed over CAT-5, the ARC’s RS-485 will be limited to 1000 ft in a star network configuration and 4000 ft in a daisy-chain network configuration. Longer distances may be possible using third party RS-485 extender products.

Connections

The RS-485 port on the back of any Ring Master SymNet hardware device at ADDR #1 should be connected to the RS-485 port on the Control I/O using shielded twisted pair cable wired in parallel. Then, CAT-5 cable should be distributed amongst the ARCs in the system preferably in a star configuration or in minimal daisy chains according to the limitations outlined previously. Finally, power can be applied to the Control I/O and programming may commence.

| CAT-5 CABLE PINOUT FOR POWER AND RS-485 DISTRIBUTION | |
|--|------------|
| Pin # | Function |
| 1 | Ground |
| 2 | Ground |
| 3 | Ground |
| 4 | RS-485 “A” |
| 5 | RS-485 “B” |
| 6 | Ground |
| 7 | Power |
| 8 | Power |

WARNING: When designing a system, one must be careful not to double power any ARCs. If all pins on the CAT-5 connections are used, power can travel over the CAT-5 cable and reach any ARC on that particular chain. So, power over CAT-5 could potentially come from the Control I/O or from an ARC that is powered locally and then daisy chained via CAT-5 to other ARCs. In general, it is recommended to use only one type of connector on the ARCs, either the RJ-45s (with CAT-5 cable) or the terminal blocks.

RS-485 Termination, MIDI I/O, Device Address Quick Reference 5/11

RS-485 Termination

Both the ARC and the Control I/O feature an RS-485 termination jumper. Jumper J17 inside the Control I/O by the RS-485 jack enables and disables termination. Jumping pins 1 and 2 = terminated, pins 2 and 3 = open. For maximum signal integrity, follow the termination guidelines below:

| RS-485 TERMINATION GUIDELINES | |
|--|--|
| Daisy chain length | Termination |
| 0 - 200 ft. | No termination required |
| 200 - 1000 ft. (if powering over CAT-5) | Terminate at Control I/O |
| > 1000 ft. (or if not powering over CAT-5) | Terminate at Control I/O and at the last ARC in each chain |

For star configurations, terminate at the Control I/O.

MIDI I/O

With the DB15 MIDI I/O “joystick” port, the Control I/O can function as a MIDI Continuous Controller (CC) to RS-485 Controller translator. The DB15 port uses a standard to (2) DIN 5 MIDI IN and MIDI OUT cable adapter. (Adapter not included). The adapter is the same that most all computer sound cards with a joystick port use and is available at many computer and music supply outlets. (Please see the SymNet Designer online help for information on how to map a MIDI Controller number to an RS-485 Controller number in a SymNet DSP design.)

Device Address Quick Reference

Every RS-485 device (including all ARCs and Control I/Os) connected to the same SymNet Ring must be uniquely identified. You may use the pictorial diagrams below to quickly set up and understand the device address DIP switches on the Control I/O. Any time the DIP switches are changed, the unit must be power cycled for the changes to take effect.

Control I/O DIP Switch Settings

NOTE: For the sake of space, only switch settings for the first 8 addresses are pictured. An address of up to 31 is possible (all DIP switches down). For systems containing 32 total Control I/O's, an address of zero (0) is available (all DIP switches UP).

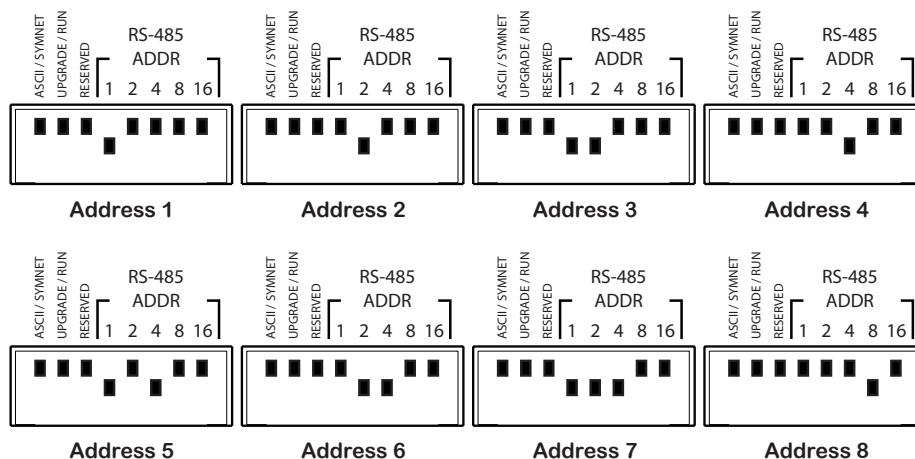

Note: The Control I/O contains field-upgradable firmware. Upgrading is facilitated by DIP switch #2 labeled “UPGRADE / RUN”. Unless instructed by Symetrix Technical Support personnel or a Symetrix Technical Bulletin, this switch should remain in the “RUN” position.

Stand-alone Operation

The Control I/O may also be used in a stand-alone fashion or integrated into other RS-485 compatible control systems such as those made by AMX or Crestron. All previous hook up information applies as well as device addressing information (with the exception of DIP switch #1 "ASCII / SYMNET", which should be down in the "ASCII" position and then the unit power cycled to enable stand-alone mode). The REMOTE ARC ports will not be of use in this application as the ARCs do not use the protocol outlined below.

ASCII Control Protocol

Introduction

The Control I/O has the capability of being used as a generic I/O control device, without the SymNet system being present. In this mode, the device accepts generic commands from the RS-485 input and respond accordingly. This section outlines how that is accomplished, and the commands supported by the device.

Control I/O Setup

Setting the second DIP switch from the left (looking from the rear) to the 'on' (down) position puts the Control I/O into the ASCII control mode. After changing modes, the unit will need to be power cycled for the setting to take effect. While in the ASCII control mode, the unit will not respond to normal SymNet commands, but instead to a simple ASCII based protocol suitable for AMX/Crestron type controllers or even a simple terminal program.

Command Set

The **<address>** field must match the value of the address on the specific unit's DIP switch. If the address field does not match, then the command is ignored and no response is sent which allows multiple units to reside on the same RS-485 bus. If the address is correct but the command isn't recognized, or any of the parameters are incorrect, a **NAK** will be returned. The address field can range from **0-31**. If everything was satisfactory, an **ACK** will be returned. Parameter values can be separated by space(s) or a comma, though numeric parameters directly following a character value need no delimitation. All numeric parameters are positive decimal integers except for the **Send MIDI String** command which accepts a string of two digit hexadecimal numbers.

(FU) Flash Front LEDs

Command:

```
FU <address><cr>
```

Where **<address>** is a decimal number **0-31**.

Response:

```
<ACK/NAK><cr>
```

(RV) Return Software Version

Returns the current firmware version of the Control I/O's microcontroller.

Command:

```
RV <address><cr>
```

Response:

```
<value> <ACK/NAK><cr>
```

Where **<value>** is the version number times 100.

(IM) Set Input Mode

Command:

```
IM <address> <input> <mode><cr>
```

Where **<input>** is a decimal number **1-8** and **<mode>** is:

P = potentiometer
E = encoder
S = dual switch

Note: Input modes are persistent with power cycling. A new unit from the factory will set all 8 inputs as dual switches.

Response:

```
<ACK/NAK><cr>
```

If **<input>** is outside the **1-8** range, or **<mode>** is not "P", "E", or "S" then a "NAK" is returned.

(RI) Read Input State

Reads the state of the analog control inputs.

Command:

```
RI <address> <input><cr>
```

Where <input> is a decimal number 1-8.

Response:

```
<value> <ACK/NAK><cr>
```

If the input is a pot, <value> is always returned as 3 decimal digits with a range of 000-255.

000 = pot arm at ground

255 = pot arm at max

If the input is an encoder, <value> is always returned as 3 decimal digits with a range of 000-255. The step size is assumed as 1. Encoder range can be limited with the **EN** and **EX** commands. When used as encoder inputs, the analog control inputs feature a built in acceleration function to speed large changes.

If the input is a dual switch, <value> is:

000 = No switches on

001 = Lower (A) switch on

010 = Upper (B) switch on

011 = Both switches on

Note: If <input> is outside the 1-8 range, a **NAK** is returned along with a <value> of 0. If the port mode wasn't previously set up, a "NAK" is returned along with a <value> of 0.

(SO) Set Open Collector Initial Value

Allows the powerup value of the open collectors to be set. This is useful for initializing the open collector outputs to a given state on powerup.

Command:

```
SO <address> <output> <state><cr>
```

Where <output> is a decimal number 1-8 and <state> is 0 for off and 1 or greater for on. When the open collector is off, the voltage at the open collector is pulled high to 5 volts allowing an attached LED to light. When the open collector driver is on, there is a low impedance between the output and ground connections allowing an external load to sink current.

Response:

```
<ACK/NAK><cr>
```

If <value> is greater than 255 or <input> is outside the 1-8 range, a "NAK" is returned. This value is saved and restored on powerup.

(OC) Open Collector Output Control

Turns open collector outputs on (active low) or off (tristate, normally pulled high). These outputs first initialize to off (high), however this initial state can be changed with the **Set Open Collector Initial Value** command.

Command:

```
OC <address> <output> <state><cr>
```

Where <output> is a decimal number 1-8 and <state> is 0 for off and 1 or greater for on. When the open collector is off, the voltage at the open collector is pulled high to 5 volts allowing an attached LED to light. When the open collector driver is on, there is a low impedance between the output and ground connections allowing an external load to sink current.

Response:

```
<ACK/NAK><cr>
```

(SR) Set Relay Initial Value

Allows the powerup value of the relays to be set. This is useful for initializing the relays to a given state on powerup.

Command:

```
SR <address> <relay> <state><cr>
```

Where <relay> is a decimal number 1-4 and <state> is 0 for off and 1 or greater for on. An off state of the relay corresponds to the NC of the relay connector being connected to the common (C) connection. An on state corresponds to the NO of the relay connector being connected to the common (C) connection.

Response:

```
<ACK/NAK><cr>
```

If <value> is greater than 255 or <input> is outside the 1-4 range, a "NAK" is returned. This value is saved and restored on powerup.

(RC) Relay Control

Turns relays on or off. These outputs first initialize to off, however this initial state can be changed with the **Set Relay Initial Value** command.

Command:

```
RC <address> <relay> <state><cr>
```

Where <relay> is a decimal number 1-4 and <state> is 0 for off and 1 or greater for on. An off state of the relay corresponds to the NC of the relay connector being connected to the common (C) connection. An on state corresponds to the NO of the relay connector being connected to the common (C) connection.

Response:

```
<ACK/NAK><cr>
```

(SE) Set Internal Encoder Initial Value

Allows the powerup value of the internal encoders to be set. This is useful for initializing the encoders to a given state on powerup.

Command:

```
SE <address> <input> <value><cr>
```

Where <input> is a decimal number 1-8 and <value> is 0-255.

Response:

```
<ACK/NAK><cr>
```

If <value> is greater than 255 or <input> is outside the 1-8 range, a "NAK" is returned. This value is saved and restored on powerup.

(EN) Set Internal Encoder Minimum Value

Allows the minimum value of the internal encoders to be set. This is useful for restricting the range of the encoder input(s).

Command:

```
EN <address> <input> <value><cr>
```

Where <input> is a decimal number 1-8 and <value> is 0-255.

Response:

```
<ACK/NAK><cr>
```

If <value> is greater than 255 or <input> is outside the 1-8 range, a "NAK" is returned. This value is saved and restored on powerup. If the minimum encoder value is set greater than the maximum encoder value, anomalous operation will occur.

(EX) Set Internal Encoder Maximum Value

Allows the maximum value of the internal encoders to be set. This is useful for restricting the range of the encoder input(s).

Command:

```
EX <address> <input> <value><cr>
```

Where <input> is a decimal number 1-8 and <value> is 0-255.

Response:

```
<ACK/NAK><cr>
```

If <value> is greater than 255 or <input> is outside the 1-8 range, a "NAK" is returned. This value is saved and restored on powerup. If the maximum encoder value is set less than the minimum encoder value, anomalous operation will occur.

(MC) Return MIDI Control Changed

Used to determine if one or more MIDI controllers have changed value.

Command:

```
MC <address><cr>
```

Response:

```
<value> <ACK/NAK><cr>
```

Where <value> is 0-127. If the value is 0, no MIDI values have changed since the last poll, else the MIDI controller number 1-127 that has changed will be returned. Each poll will return the lowest numbered changed controller until all the changed parameters have been reported. Only MIDI channel 1 is decoded (where lower nibble = 0 in the MIDI control change command byte) A typical poll sequence would be:

```
If (Ctrl = MC<addr>) != 0 then Value = RM<addr> <Ctrl>
```

(RM) Read MIDI Input Value

Allows an external MIDI input to be read by an RS-485 controller.

Command:

```
RM <address> <controller><cr>
```

Where <controller> is a decimal number 1-127.

Response:

```
<value> <ACK/NAK><cr>
```

Where <value> is a decimal number 0-127.

If <controller> is outside the 1-127 range, a "NAK" is returned along with a value of 0. Only MIDI channel 1 is decoded (where lower nibble = 0 in the MIDI control change command byte).

(SM) Send MIDI String

Allows MIDI strings to be sent to the Control I/O via RS-485, then output on the MIDI out connector. **Note:** the maximum string length is 512 MIDI characters including all delimiters. Longer strings must be sent using multiple invocations of the command. The data is in decimal format. The string is stored until the <cr> is received, then sent out in one block.

Command:

```
SM <address> <$data byte 1>...<$data byte n><cr>
```

Response:

```
<ACK/NAK><cr>
```

Quick Start Guide

Control I/O



To download the latest version of SymNet Designer, the Windows application that controls all SymNet hardware, go to: www.symnetaudio.com

Warranty and Service

11/11

The Symetrix Limited Warranty

Symetrix, Inc. expressly warrants that the product will be free from defects in material and workmanship for eighteen (18) months from the date the product is shipped from the factory. Symetrix's obligations under this warranty will be limited to repairing or replacing, at Symetrix's option, the part or parts of the product which prove defective in material or workmanship within eighteen (18) months from the date the product is shipped from the factory, provided that the Buyer gives Symetrix prompt notice of any defect or failure and satisfactory proof thereof. Products may be returned by Buyer only after a Return Authorization number (RA) has been obtained from Symetrix. Buyer will prepay all freight charges to return the product to the Symetrix factory. Symetrix reserves the right to inspect any products which may be the subject of any warranty claim before repair or replacement is carried out. Symetrix may, at its option, require proof of the original date of purchase (dated copy of original retail dealer's invoice). Final determination of warranty coverage lies solely with Symetrix. Products repaired under warranty will be returned freight prepaid via United Parcel Service by Symetrix, to any location within the Continental United States. Outside the Continental United States, products will be returned freight collect.

The foregoing warranties are in lieu of all other warranties, whether oral, written, express, implied or statutory. Symetrix, Inc. expressly disclaims any IMPLIED warranties, including fitness for a particular purpose or merchantability. Symetrix's warranty obligation and buyer's remedies hereunder are SOLELY and exclusively as stated herein.

This Symetrix product is designed and manufactured for use in professional and studio audio systems and is not intended for other usage. With respect to products purchased by consumers for personal, family, or household use, **Symetrix expressly disclaims all implied warranties, including but not limited to warranties of merchantability and fitness for a particular purpose.**

This limited warranty, with all terms, conditions and disclaimers set forth herein, shall extend to the original purchaser and anyone who purchases the product within the specified warranty period.

Symetrix does not authorize any third party, including any dealer or sales representative, to assume any liability or make any additional warranties or representation regarding this product information on behalf of Symetrix.

This limited warranty gives the buyer certain rights. You may have additional rights provided by applicable law.

Note: Some Symetrix products contain embedded software and may also be accompanied by control software intended to be run on a personal computer. Said software is specifically excluded from this warranty.

Limitation of Liability

The total liability of Symetrix on any claim, whether in contract, tort (including negligence) or otherwise arising out of, connected with, or resulting from the manufacture, sale, delivery, resale, repair, replacement or use of any product will not

exceed the price allocatable to the product or any part thereof which gives rise to the claim. In no event will Symetrix be liable for any incidental or consequential damages including but not limited to damage for loss of revenue, cost of capital, claims of customers for service interruptions or failure to supply, and costs and expenses incurred in connection with labor, overhead, transportation, installation or removal of products, substitute facilities or supply houses.

Servicing the Control I/O

If you have determined that your Control I/O requires repair services and you live outside of the United States please contact your local Symetrix dealer or distributor for instructions on how to obtain service. If you reside in the U.S. then proceed as follows.

Return authorization

At the Symetrix factory, Symetrix will perform in-warranty or out-of-warranty service on any product it has manufactured for a period of three (3) years from date of discontinued manufacture.

Before sending anything to Symetrix, please contact our Customer Service Department for a return authorization (RA) number. The telephone number is (425) 778-7728. Additionally support is available via E-mail through tech@symetrixaudio.com or via the web site <http://www.symetrixaudio.com>.

In-warranty repairs

To get your Control I/O repaired under the terms of the warranty:

1. Call us for an RA number (have the serial number, shipping and contact information and description of the problem ready).
2. Pack the unit in its original packaging materials.
3. Include your name, address, daytime telephone number, and a brief statement of the problem.
4. Write the RA number on the **outside** of the box.
5. Ship the unit to Symetrix, freight prepaid. We do not accept freight collect shipments.

Just do these five things, and repairs made in-warranty will cost you only one way freight charges. We'll pay the return freight.

If you don't have the factory packaging materials, we recommend using an oversize box. Wrap the unit in a plastic bag, surround it with bubble-wrap, and place it in the box surrounded by Styrofoam peanuts. Be sure there is enough clearance in the box to protect the rack ears. We won't return the unit in anything but Symetrix packaging for which we will have to charge you. If the problem is due to operator misuse or error, you will have to pay for both parts and labor. In any event, if there are charges for the repair, you will pay for the return freight. All charges will be COD unless you have made other arrangements (prepaid, Visa or Mastercard).

Out-of-warranty repairs

If the warranty period has passed, you'll be billed for all necessary parts, labor, packaging materials, and freight charges. Please remember, you must call for an RA number before sending the unit to Symetrix.