

**Model**  
***528E Voice Processor***



**528E**

**User's Guide**

528E

Symetrix Inc.  
14926 35th Avenue West  
Lynnwood, Washington 98037  
voice: (425) 787-3222  
(800) 288-8855  
fax: (425) 787-3211



**Symetrix**  
**528E**  
**Voice Processor**

## Owner's Manual

**Rev B, 4/2/1998**

**Part number: 53528E0B00**

Subject to change at our whim, and without notice.

Copyright (c) 1992-1996, Symetrix Inc. All rights reserved.

Batteries not included. Ground isn't ground!

Available at finer studios everywhere.

*No part of this manual may be reproduced or transmitted in any form or by any means, electronic or mechanical, including photocopying, recording or by any information storage and retrieval system, without permission, in writing, from the publisher.*

## **Production Information**

This document was written using Microsoft Word for Windows V2.0 and 6.0. The drawings and graphs in this manual were prepared using Corel Draw V2.0, Autocad V12, and Autoscript V5, then imported into Word for Windows via encapsulated PostScript files. All page makeup occurred within Word for Windows.

Body text is set in Bookman 10pt and Section Heads are set in various sizes of Helvetica Bold. Helvetica-Narrow was used for Figure and Table captions.

This manual was printed directly from PostScript files generated by Word for Windows on a Xerox Docutech printer. This unique device is actually a laser printer, capable of 600 dpi resolution, with a page throughput that rivals a high-speed photocopier. As a result, every page is a first-generation image.

Ain't technology grand?

# Table of Contents

<b>1. Introduction.....</b>	<b>1-1</b>
1.1 Manual Sections.....	1-2
1.2 Operator Safety Summary.....	1-2
1.2.1 Terms.....	1-3
1.3 Other Safety Information.....	1-3
<b>2. Basics.....</b>	<b>2-1</b>
2.1 Dynamic Range Processing.....	2-1
2.1.1 Defining Dynamic Range.....	2-1
2.1.2 Dynamic Range as a Specification.....	2-2
2.1.3 Dynamic Range of Sounds and Signals.....	2-2
2.1.4 Why Dynamic Range Processors are Necessary.....	2-2
2.1.5 Compressors are to Downward Expanders as Limiters are to Gates.....	2-3
2.1.6 The Threshold Concept.....	2-3
2.1.7 The VCA - Voltage Controlled Amplifier.....	2-3
2.1.8 Linear vs. Downward Expanders.....	2-3
2.1.9 How Expanders Increase Usable Dynamic Range.....	2-4
2.1.10 De-essers.....	2-4
2.1.11 Sidechain Processing.....	2-4
2.2 Equalization.....	2-5
2.2.1 Equalization Tutorial.....	2-5
2.2.2 Power and Fullness.....	2-6
2.2.3 Rhythm and Musical Foundation.....	2-6
2.2.4 Telephone Quality.....	2-6
2.2.5 Lipping Quality.....	2-7
2.2.6 Presence Range.....	2-7
2.2.7 Brilliance.....	2-7
2.2.8 Conclusions.....	2-7
2.2.9 Using the Parametric Equalizer.....	2-8
2.2.10 Beware of Distortion and Noise.....	2-8
2.2.11 Know What You Are Listening To.....	2-8
2.2.12 Use Wide Peaks, Narrow Dips.....	2-8
2.2.13 Tuning the EQ/Notch Filter.....	2-8
2.2.14 Equalizing for Speech.....	2-9
<b>3. Technical Tutorial.....</b>	<b>3-1</b>
3.1 Matching Levels vs Matching Impedances.....	3-1
3.2 Signal Levels.....	3-2
3.3 I/O Impedances.....	3-2
3.4 Polarity Convention.....	3-3
3.5 Input and Output Connections.....	3-3
3.6 Phantom Powering Condenser Microphones.....	3-5
<b>4. Front Panel Overview.....</b>	<b>4-1</b>
<b>5. Rear Panel Overview.....</b>	<b>5-1</b>

<b>6. Fast First Time Setup</b> .....	<b>6-1</b>
6.1 Connections .....	6-1
6.2 Settings .....	6-1
6.3 Initial Setup.....	6-2
6.4 Refining Your Settings.....	6-2
6.4.1 Mic Preamp Gain .....	6-2
6.4.2 De-Esser Settings.....	6-2
6.4.3 Downward Expander Settings .....	6-2
6.4.4 Compressor Settings .....	6-2
6.4.5 Equalizer Settings.....	6-3
6.4.6 Output Settings.....	6-3
<b>7. Using the 528E</b> .....	<b>7-1</b>
7.1 Block Diagram .....	7-1
7.2 Installation .....	7-2
7.3 Level Setting.....	7-2
7.4 Operational Details.....	7-2
7.4.1 Stand-alone Operation .....	7-2
7.4.2 Using the 528E as a Channel Insert Device .....	7-3
7.4.3 Using the 528E in an Effects Loop .....	7-3
7.5 Using the Patch Points .....	7-3
7.5.1 Inserting Additional Processing .....	7-4
7.5.2 Changing the Sequence of Processing .....	7-4
7.5.3 Using the Equalizer in the Sidechain .....	7-4
7.6 Tips and Techniques for Using the 528E .....	7-5
7.6.1 Metering.....	7-5
7.6.2 Gain Setting.....	7-5
7.6.3 Equalization .....	7-5
7.6.4 De-Esser.....	7-6
7.6.5 Compression.....	7-6
7.6.6 Downward Expander .....	7-6
7.6.7 Using the Sidechain.....	7-7
7.6.8 The Voice Symmetry Switch.....	7-7
<b>8. Applications</b> .....	<b>8-1</b>
8.1 Broadcast Applications .....	8-1
8.2 Announce Mics - Compressing, Limiting, Expanding.....	8-1
8.3 Using the De-esser.....	8-2
8.4 Cleaning Up News Feeds.....	8-2
8.5 Increasing Gain Before Feedback .....	8-2
8.6 Parametric EQ in the Sidechain .....	8-3
8.7 Using Sidechain EQ to Enhance Expander Action .....	8-3
8.8 Using Reverb or Effects.....	8-3
8.9 Vocal Processing - Recording and Reinforcement .....	8-4
8.10 Adding Dynamics, or "Punch".....	8-4
8.11 High Level Stage Monitors - Dynamic Processing.....	8-4
<b>9. Troubleshooting Chart</b> .....	<b>9-1</b>
<b>10. Repair and Warranty Information</b> .....	<b>11-1</b>
<b>11. Specifications</b> .....	<b>11-1</b>
<b>Appendix A. Architects and Engineers Specification</b> .....	<b>A-1</b>
<b>Appendix B. Disassembly Instructions</b> .....	<b>B-1</b>

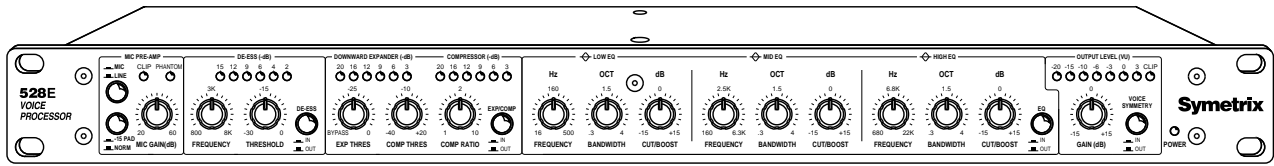

## 1. Introduction.

The **Symetrix 528E** is a single-channel Voice Processor intended for use in voice-over studios, broadcast studios, sound-reinforcement, music and speech recording, and post-production. Simply stated, the 528E consists of a high-quality microphone preamp coupled to a three-band parametric equalizer, a de-esser, and a dynamic range processor. It is everything you would have at your disposal in a world-class mixing console. The 528E accepts both mic and line inputs. Of course, while we use the term "Voice Processor" for the 528E, it is perfectly at home with any signal, vocal or not.

The microphone input uses a balanced-transformerless design using an integrated circuit specifically developed for this application. The 528E's microphone input works with any phantom-powered condenser microphone or any low-impedance microphone having a balanced, floating output.

The line input uses a balanced transformerless design. The line input's design uses matched resistors to attain a high, wideband, CMRR (common-mode rejection ratio) and multi-stage RFI filters to prevent Radio Frequency interference problems.

The de-esser operates by selectively removing the high frequencies from the input signal when sibilant sounds are present and exceed the threshold level. The filter frequency can be varied over a wide range to accommodate different speakers and languages.

The dynamic range processor combines an interactive compressor/limiter and a downward expander. Typically, the downward expander helps reduce studio noise as well as the artifacts of close miking. The compressor/limiter gives you overall control over the dynamic range of the output signal and helps maintain a high overall signal level.

The three-band parametric equalizer is a reciprocal-curve design. An unusual leap-frog topology minimizes the number of amplifiers in the signal path while ensuring that each frequency band interacts with its neighbor in a desirable and musical fashion.

The 528E's output section can drive balanced loads at line or mic levels. A line-level unbalanced output is also provided. For broadcast applications, a switchable voice symmetry circuit helps make speech waveforms more symmetrical, which makes better use of the transmitter's output power.

Each of the dynamics processors have individual six-segment LED displays and an eight-segment display monitors the overall output level.

All inputs and outputs are available via XLR connectors and the connection points between the individual processors can be accessed via TRS phone jacks. The interstage patching may be used to change the insertion order of the processors or to insert additional processing.

We recommend that you read this manual from cover to cover. Somewhere between the confines of the two covers you should find the answers to most (98%) of your questions, both technical as well as musical.

If you're in a hurry (like most of us), or if you really don't believe that someone could write a decent owners manual that you can read and understand, then do us both a favor and read the remainder of this section and Section 6, "Fast First Time Setup." This section will help you get connected, tell you what the knobs do, and send you on your way.

## 1.1 Manual Sections

This manual contains the following sections:

**Chapter 1.** *Introduction* introduces the 528E and this manual. Describes important safety information

**Chapter 2.** *Basics* lets you know what the 528E does, and how it does it.

**Chapter 3.** *Technical Tutorial* a basic and not-so-basic discussion of signal levels, input and output impedances, connection polarity, and phantom powering.

**Chapter 4.** *Front Panel Overview* gives a brief look at the controls and switches of the 528E.

**Chapter 5.** *Rear Panel Overview* gives a brief look at the connectors of the 528E.

**Chapter 6.** *Fast, First Time Setup* is a section written especially for people who just can't wait to get their hands on the knobs.

**Chapter 7.** *Using the 528E* describes the use of the 528E in detail.

**Chapter 8.** *Applications* describes some of the myriad uses for the **528E**.

**Chapter 9.** *Troubleshooting* tells what to do if the 528E doesn't work.

**Chapter 10.** *Repair and Warranty Information* tells how to get your 528E repaired and describes the 528E's warranty.

**Chapter 11.** *Specifications* lists the technical specifications of the 528E's performance.

**Appendix.** *Appendices* contains the Architects and Engineer's specifications and disassembly instructions.

## 1.2 Operator Safety Summary

The information in this summary is intended for persons who operate the equipment as well as repair personnel. Specific warnings and cautions are found throughout this manual wherever they may apply; they do not appear in this summary.

The notational conventions used in this manual and on the equipment itself are described in the following paragraphs.

The lightning flash with arrowhead symbol within an equilateral triangle is intended to alert the user of the presence of uninsulated "dangerous voltage" within the product's enclosure that may be of sufficient magnitude to constitute a risk of electric shock to persons.

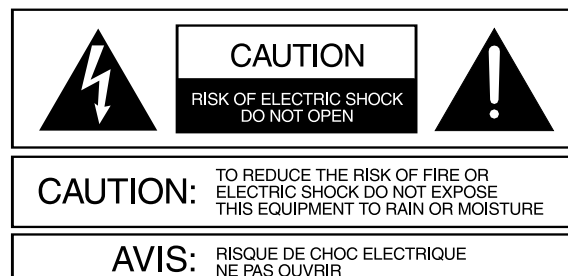

No user serviceable parts inside. Refer servicing to qualified service personnel.  
il ne trouve a l'interieur aucune piece pouvant entre reparee l'usager.  
S'adresser a un reparateur competent.

The exclamation point within an equilateral triangle is intended to alert the user of the presence of important operating and maintenance (servicing) instructions in the literature accompanying the appliance (i.e. this manual).

**Caution:** *To prevent electric shock, do not use the polarized plug supplied with this appliance with any extension cord, receptacle, or other outlet unless the blades can be fully inserted to prevent blade exposure.*



### 1.2.1 Terms

Several notational conventions are used in this manual. Some paragraphs may use Note, Caution, or Warning as a heading. These headings have the following meaning:

Convention	Description
<b>Caution</b>	<i>Identifies information that, if not heeded, may cause damage to the 528E or other equipment in your system.</i>
Note	Identifies information that needs extra emphasis. A Note generally supplies extra information to help you use the 528E better.
<b>Warning</b>	<b>Identifies information that, if ignored, may be hazardous to your health or that of others.</b>

In addition, certain typefaces and capitalization are used to identify certain words. These situations are:

Convention	Meaning
CAPITALS	Controls, switches or other markings on the chassis.
<b>Boldface</b>	Strong emphasis.

Finally, two symbols are used as visual hints. They are:

Symbol	Meaning
N	Helping hand. A hint to make your life a bit easier.
	The Bomb. A visual way of saying, "Caution!"

### 1.3 Other Safety Information

Power Source	This product is intended to operate from a power source that does not apply more than 250V rms between the power supply conductors or between either power supply conductor and ground. A protective ground connection, by way of the grounding conductor in the power cord, is essential for safe operation.
Grounding	The chassis of this product is grounded through the grounding conductor of the power cord. To avoid electric shock, plug the power cord into a properly wired receptacle before making any connections to the product. A protective ground connection, by way of the grounding conductor in the power cord, is essential for safe operation.

Danger from Loss of Ground	If the protective ground connection is lost, all accessible conductive parts, including knobs and controls that may appear to be insulated, can render an electric shock.
Proper Power Cord	Use only the power cord and connector specified for the product and your operating locale. Use only a cord that is in good condition.
Proper Fuse	The fuse is mounted internally and is not considered user serviceable. The fuseholder accepts American sized fuses (1/4 in dia.) or European sized fuses (5mm dia). For 117V ac operation, the correct value is <b>1/4A, 250V ac, fast blowing</b> (Bussman type AGC) For 230V ac operation, the correct value is <b>1/8A, 250V ac, slow blowing</b> (Bussman type MDL or GDC).
Operating Location	Do not operate this equipment under any of the following conditions: explosive atmospheres, in wet locations, in inclement weather, improper or unknown AC mains voltage, or if improperly fused.
Stay Out of the Box	To avoid personal injury (or worse), do not remove the product covers or panels. Do not operate the product without the covers and panels properly installed.
User-serviceable parts	There are no user serviceable parts inside the 528E. In case of failure, refer all servicing to the factory.

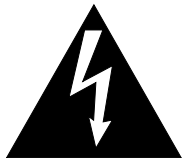

**To prevent hazard or damage, ensure that only microphone cables and microphones designed to IEC-268-15A are connected.**

## 2. Basics

The **Symetrix 528E Voice Processor** combines Symetrix' program controlled interactive dynamic range processing technique with a three-band parametric equalizer. This combination of processors is similar to a voiceover or vocal signal processing chain as used in a recording or voiceover studio. "Program controlled" means the 528E's dynamic range processor section analyzes incoming signals, then adjusts its release time to match the transient characteristics of those signals.

This chapter of the manual contains a tutorial on the basics of dynamic range processing and equalization: the two key ingredients in the 528E. The tutorial information is intended to provide a background for the information found in the remainder of this manual.

### 2.1 Dynamic Range Processing

Dynamic range processors are used to fit wide-range signals into narrow-range transmission or storage channels. The dynamic range of acoustical signals found in real life usually far exceeds our capacity to store or transmit them. Confronted with this dilemma, audio engineers usually reach for a compressor/limiter or downward expander as a means to fit two-pound signals into one-pound bags.

Compressor/limiters respond quickly to transients, and gently to normal speech level changes which keeps overall levels in check. The downward expander's operation is the inverse of the compressor/limiter which prevents "pumping" and "breathing" even when high ratio compression is necessary. Because the compressor/limiter and the downward expander are interactive, the 528E always responds appropriately, while providing automatic control over a wide range of input levels.

Strictly speaking, the terms compressor and limiter refer to two different devices. Oftentimes the two are combined into a single device called a compressor/limiter. Compressor/limiters usually perform as either a compressor or a limiter, but not both at once. Functionally, a compressor/limiter is a device that lets the user define, or predetermine, the maximum level of an audio signal.

Expanders and gates are the functional opposites of compressors and limiters. Compressors continuously reduce the dynamic range of signals that are above threshold, while expanders continuously increase the dynamic range of signals that are below threshold. Limiters can be thought of as very high ratio compressors, and gates can be thought of as very high ratio expanders.

In addition to their roles as remedial signal processors, compressors also have a creative role. You can use a compressor to increase the apparent sustain of a guitar, increase apparent loudness, improve the consistency of a bass by removing or reducing level changes, and many other things. Generally speaking, the settings for these applications are somewhat extreme, so experimentation is the name of the game.

#### 2.1.1 Defining Dynamic Range

To begin a discussion of dynamic range processors it's necessary to have a working definition of dynamic range. The term is really self-descriptive, but has two distinctly different uses:

1. To describe the actual range of signal fluctuations that are going through the equipment.
2. To define the maximum allowable range of signal fluctuations that can be put through the equipment.

The usual unit of measure for audio signals is the decibel (dB).

## 2.1.2 Dynamic Range as a Specification

The maximum usable range of operation for a particular circuit or piece of gear is the distance in dB between the noise floor and the maximum output level. In this context, dynamic range is used as an equipment specification.

Noise floor is defined as the lower limit of a circuit's operating level, and is a function of its self-generated electrical noise. Very noisy circuits have a high noise floor, quiet circuits have a low noise floor. All circuits have a noise floor, unless they are operating at -460 degrees Fahrenheit (absolute zero). The maximum output level of a circuit is the upper limit of the operating level, and is the level at which clipping begins and is a function of the internal power supply voltage. To put levels in perspective they must be referenced to some nominal operating level, like 0 dBm. That's why noise specs are stated as negative numbers.

In the case of the 528E, noise is referred to the input, and stated as equivalent input noise (EIN). The noise specification is given this way because the gain of the 528E's input stage is variable, so the actual signal-to-noise performance of the unit becomes a function of how much gain is used in the preamp. To find the signal-to-noise ratio at 0 dBm output, algebraically add the preamp gain to the EIN.<sup>1</sup>

Since maximum output level is usually greater than 0 dBm, it's stated as plus something. The 528E's maximum output level is **+18 dBm into a 600-ohm** balanced load, which is **18 dB** above 0 dBm. The difference between the noise floor and the onset of clipping is the dynamic range. To find the 528E's dynamic range with 50 dB preamp gain, subtract **-89** from **18**. The result (113 dB) is the dynamic range.

## 2.1.3 Dynamic Range of Sounds and Signals

The other definition of dynamic range describes actual level changes, or the range over which signals fluctuate. The signals under discussion here are electrical representations of sounds, so it follows that sound has dynamic range. The dynamic range of the human voice, from a whisper to a shout, is well over 100 dB. Thus, the microphone converts the sound pressure of a voice going from a whisper to a shout into an electrical output signal having the same dynamic range.

## 2.1.4 Why Dynamic Range Processors are Necessary

For signals to stay below distortion and above noise, their actual dynamic range must be kept within the specified dynamic range of the circuits through which those signals flow. Unfortunately, the actual dynamic range of real world signals often exceeds the available dynamic range of even the best equipment.

For example, the dynamic range of the best analog tape recorders is around 80 dB, while digital recorders top out at around 96 dB. As good as these machines are, there's still not quite enough room for very wide dynamic range signals. In order to maintain a 60 dB signal-to-noise ratio (to keep the signals 60 dB above the noise floor), the dynamic range of signals stored on the analog tape machine would have to be restricted by 20 dB, while the digital recorder would be restricted by 36 dB.

A compressor or limiter is often used to reduce dynamic range by setting an upper limit on the larger signals. In some cases, it's better to put processing to work on the lower end of the dynamic range than on the upper end. In other words, instead of reducing the amount of change at the upper end of the dynamic range with a compressor or limiter, increasing the amount of change at the lower end of the dynamic range with a downward expander or gate.

---

<sup>1</sup> Equivalent input noise (EIN) is a method of modeling the noise performance of a preamp as the signal level of an equivalent noise source connected to the input of a noiseless preamplifier. The thermal noise of a 150-ohm resistor is about -133dBV; this represents the theoretical best case.

## 2.1.5 Compressors are to Downward Expanders as Limiters are to Gates

Compressors reduce the dynamic range of their output whenever the input signal is above threshold, while downward expanders increase the dynamic range of their output whenever the input signal is below threshold.

Compressors, limiters, expanders, and gates increase or decrease signal levels by some ratio. Compressors usually have an adjustable ratio, the ratio of the input level to the output level, which is generally user-adjustable. A compressor operating with a 2:1 ratio allows only a 1 dB increase in output level for every 2 dB increase in input level.

Limiters usually have a non-adjustable ratio that is very high (greater than 10:1). At 10:1, the limiter allows only a 1 dB increase in the output level for every 10 dB increase in the input level. Limiters can be thought of as high ratio, high threshold compressors. They are intended to "stay out of the way" until the level goes above threshold. However, above threshold their action is very definite.

## 2.1.6 The Threshold Concept

The threshold is the level at which a dynamic range processor's activity begins. In operation, the dynamic range processor's sensing circuitry constantly "looks at" the incoming signal and compares it to a reference level, which is called the threshold level. In practice that reference level is set by the operator via the threshold control. Remember, compressors and limiters respond when signals at the input are above threshold, while downward expanders and gates respond only when signals at the input are lower than the defined threshold.

## 2.1.7 The VCA - Voltage Controlled Amplifier

The action of any dynamic range processor depends on some method of changing the gain based on some external signal. Typically this takes the form of a special sort of amplifier whose gain is controlled by a DC voltage. That part of the circuit is called a voltage controlled amplifier, or VCA. Inside the 528E a separate buffered audio signal is sent to a group of circuits that comprise the detector (envelope follower to you synthesists). The detector circuits turn the AC audio signal into a DC control voltage, which is sent to the VCA under the direction of the front panel controls.

## 2.1.8 Linear vs. Downward Expanders

Expander operation is easily misunderstood unless it's remembered that what's being expanded is the dynamics, or changes, of signals passing through the circuit. Expanders come in two very different types: linear, and downward.

Linear expanders increase the dynamic range of all signals, no matter what their actual level. The linear expander simply makes all changes greater by some ratio, which is sometimes user adjustable. In the real world, linear expanders aren't too practical because clipping occurs when signals just below maximum output level are expanded.

For instance, an unprocessed signal 3 dB below clipping that increases 2 dB won't distort, because it's still 1 dB below maximum. But if that same signal is passed through an expander operating at a 1:2 ratio, the same 2 dB change at the expander's input becomes a 4 dB change at its output. However, that signal would be 1 dB over maximum, causing distortion. Linear expanders must be used with care, because very few systems have enough headroom to handle the upward dynamic range increase they produce.

The kind of processor most commonly called an expander is really a downward expander, because it only affects signals below threshold. This gives the operator control over the expander's activities, allowing it to be used to expand the usable dynamic range of the system without running out of headroom.

**Note:** in the interests of clarity and brevity, the term *expander* will be defined as a *downward expander* from this point forward in this manual.

## 2.1.9 How Expanders Increase Usable Dynamic Range

The lower limit restriction of a system is the noise floor, which is usually well below the 528E's lowest expander threshold (-50 dBu). It's important to keep in mind that while the signal levels may change greatly, the noise usually doesn't change very much. The action of the expander increases the dynamic range of all signals below threshold. This action increases the apparent loudness of signals, while decreasing the apparent loudness of the noise.

For example, an expander operating at a ratio of 1:2 will cause an input signal that falls 10 dB below threshold to fall 20 dB at its output. The downward action of the expander reduces the noise floor by the same ratio applied to the signal. Since the relationship between the signal and the noise stays the same, the noise is reduced 20 dB by the action of expander, which is responding to a 10 dB drop in the signal with its 1:2 ratio.

### 2.1.10 De-essers

A de-esser is another type of dynamic range controller that's specially designed to regulate high frequency content. The technique was originally developed for motion picture dialogue recording, when it was discovered that speech sounded more natural and pleasing when the accentuation of sibilants was reduced. By sensing and limiting certain selected frequencies, the de-esser is intended to provide more specific control over some of the higher frequency vocal sounds that tend to become over-emphasized especially when the talker is close-miked.

Many sibilant vocal sounds like "s," "sh," and "t" are very difficult to reproduce electronically, because they contain a large percentage of very high frequency harmonics. But because these sounds are essential to the intelligibility of speech, they cannot be simply removed with equalization. In fact, to help maintain articulation many sound engineers boost the higher frequencies of the vocal spectrum (3 kHz to 8 kHz), and/or use microphones with "presence curves." However, in certain individuals sibilant sounds are already over-accentuated, and any kind of high frequency boost only exacerbates the situation.

The 528E's de-esser controls excessive sibilant and fricative vocal sounds, which can often be as much as 12 dB louder than the rest of the spectrum. It's activity is similar to a frequency conscious compressor/limiter (with an equalizer boosting the high frequencies in the sidechain). Unlike a compressor/limiter however, the de-esser operates only on the frequencies selected and above. Unlike an equalizer, the de-esser can reduce the offending sounds without sacrificing intelligibility, because it operates dynamically, removing only sounds that are disproportionately loud, and only those that fall within the operator-selected control range.

De-essers usually include controls that allow the operator to determine which frequencies are controlled, and how much those frequencies are actually attenuated. The 528E's de-esser controls are frequency, which is variable from 800 Hz to 8 kHz, and threshold, which may be set from 0 dB to -30 dB. In other words, the 528E's de-esser will attenuate selected frequencies between 800 Hz and 8 kHz as much as 20 dB.

### 2.1.11 Sidechain Processing

The sidechain is a patch point in the control circuit of a dynamic range processor, which provides access to the part of the circuitry that tells the VCA what to do. The 528E's sidechain routes through a rear panel TRS jack that allows the control signal to be processed outside the unit (see Chapter 7 for specific hookup information).

Refer to the block diagram in Figure 7-1. Notice the sidechain connections that come from the compressor/limiter/expander section. They allow access to the audio input of the control circuit (a fancy envelope follower by any other name) for the dynamic range processor. This control signal is derived from, but kept totally separate from, the audio signal path. That means the control signal can be processed outside the 528E without actually processing the signal that's going through the VCA (the audio signal itself). This presents some very

interesting possibilities for changing or improving the operation of the dynamic range processor.

The best use of the sidechain connections is to make the action of the 528E's dynamics processor frequency dependent, that is, to make it respond more (or less) to certain frequencies. Because the audio signal and the control signal remain completely separate (even while the control circuit tells the VCA whether to turn the gain up or down), you can equalize the sidechain without changing the EQ in the main audio path.

Removing unwanted frequencies from the control signal before it actually reaches the VCA prevents those frequencies from being used to create gain changes. Applications utilizing the sidechain may be found in Chapter 8.

## 2.2 Equalization

Equalization is one of the most powerful tools available to the audio engineer. It is, quite possibly, the first signal modification device that most people experience (aside from the volume control). This experience takes the form of using the tone controls found on most consumer audio equipment. Even in this primitive form, simple tone controls can shape and alter a sound, giving us pleasure or pain, evoking emotion, or simply enhancing our listening pleasure.

The parametric EQ in the 528E provides both creative and corrective frequency shaping - it can be used to create a more pleasing sound, and to correct frequency response problems. The equalizer has a symmetrical  $\pm 15$  dB boost/cut response.

The term "parametric" simply refers to the fact that the primary operating parameters of the equalizer may be altered by the user. The user adjustable parameters are:

- center frequency (or  $f_c$ , expressed in Hz),
- bandwidth (sometimes called "Q," or selectivity, expressed in octaves), and
- the amount of cut or boost (expressed in dB).

These terms are defined as follows:

1. Center Frequency is defined as the frequency (in Hz) of the middle of the bell shaped response curve formed by a filter.
2. Bandwidth is the width of the bell shaped curve, measured between its -3 dB points. The measure of bandwidth in audio equalizers is usually given in octaves or parts of an octave.
3. Cut or Boost is given in dB, at the center frequency.

### 2.2.1 Equalization Tutorial

Equalization is nothing more than selectively (or not) amplifying a signal based on frequency. Since audio signals consist of combinations of fundamental signals and their harmonics, changing the tonality or the spectral balance of a signal involves nothing more than altering the relationship of the fundamental to its harmonics, and of the harmonics to themselves. Each harmonic is responsible for one aspect of the audible character of a signal; knowing these relationships allows you to quickly zero-in on the correct frequency range of the signal and apply boost or cut to enhance or correct what you are hearing.

The audio spectrum has several critical portions that are responsible for our perceptions of sounds that we hear:<sup>2</sup>

Range	Frequencies	Musical Location
Very Low Bass	16-64 Hz	1st and 2nd octaves.
Bass	64-256 Hz	3rd and 4th octaves.
Midrange	256-2048 Hz	5th, 6th, and 7th octaves.
"Lisping" Quality	3000 Hz	Between the 7th and 8th octaves.
Presence Range	4750-5000 Hz	Between the 8th and 9th octaves.
Brilliance	6500-16 kHz	Part of the 9th through the 10th octave.

## 2.2.2 Power and Fullness.

In the very low bass region lies the threshold of feeling, where the lowest sounds, like wind, room effects, and distant thunder, are felt, rather than heard. In the upper half of the first octave of this range, research has shown that the fundamentals of piano, organ and even the harp reach well into this range. Harvey Fletcher (of Fletcher-Munson fame) charted the sensitivity of the ear for various parts of the spectrum at levels that are lower than those of reality. Fletcher's compensation curves (the well known Fletcher-Munson curves) show that for equal loudness in this range at lower recorded and reproduced levels shows requirements for tremendous boosts, on the order of 10 to 30 dB. Aside from the subjective effects of this range, the ability to control unwanted sounds in this range is equally important to subdue stage rumble and outside traffic noise (especially important where there are subways beneath buildings!). Overemphasis caused by close cardioid microphone placement can cause muddiness in the overall sound; attenuating (cutting) the very-low-bass region can greatly improve overall clarity.

## 2.2.3 Rhythm and Musical Foundation.

In the bass region, most of the low, grave tones of the drum and piano can be found. Here we can also find the fundamentals of the rhythm section, as well as the foundation of all musical structure.

It was Leopold Stowkowski who said "If I had a thousand bass viols I could use them all!" This is not as extreme as it may sound. A bass viol, even though it is reinforced by its sounding board, generally plays single notes and possesses little dynamic range. In a large orchestra, as many as eight bass viols may be used. A total of 1000 bass viols in this case would only give an additional 21 dB of level, which is not an inordinate amount given a glance at Mr. Fletcher's equal loudness curves. Pay attention to this range because the overall musical balance of your program can be controlled by equalizing or attenuating the 100 Hz range.

## 2.2.4 Telephone Quality

The ear is reasonably sensitive in the midrange frequencies, and sound restricted to this range has a telephone-like quality (which is generally why telephone-quality frequency response covers the 300-3 kHz range).

If you make the 6th octave (500-1024 Hz) louder with respect to the other octaves, the subjective result is a horn-like quality. If you emphasize the 7th octave (1000-2000 Hz), the effect is one of tinniness.

The fundamental tones in most music lie equally above and below middle C (261 Hz), from 128 to 512 Hz. As most instruments are rich in the first overtones, the majority of sound energy is found up to the 2.5 kHz range. Music editors and others engaged in listening to music over long

---

<sup>2</sup> The majority of the material in Section 2.2 is taken from "Equalizing for Spectral Character," Langevin Corporation, 1966 Catalog.



periods find that listening fatigue can be reduced by attenuating the 5th, 6th, and 7th octaves by about 5 dB.

### **2.2.5 Lispings Quality**

*The 3 kHz range delivers a generous stimulus to the ear. At very loud levels the region of greatest ear sensitivity shifts downward from 5 kHz; this is why many "PA" speakers have broad peaks in this region. A characteristic of low-level signals peaked at 3 kHz is a "lispings" quality, and the total inability to distinguish labial sounds such as m, b, and v.*

*In wide-range lower level systems, a peak in the 3 kHz region has a masking effect on important recognition sounds, and on others which lie above 4 kHz. Brilliance and clarity are lost and without attenuation of this region, an unconscious strain with increasing fatigue is felt according to the amount of 3 kHz boost.*

### **2.2.6 Presence Range**

*The usual band affecting clarity in male speech is 3000 to 6000 Hz. In a woman's voice, the fundamentals are roughly an octave higher than a man's, and a woman's range of consonant clarity lies between 5000 and 8000 Hz (the high-end of this range approaches a region of hearing insensitivity in humans). Furthermore, the total range of a woman's voice is about half that of a mans, stimulating fewer hearing nerves, and for this reason, is consequently still weaker upon reception.*

*Wide range sounds, especially those of singing voices, have fundamentals with harmonics in the 5 kHz region of good ear sensitivity. Voices that are powerful or rich with harmonics at 5 kHz sound especially pleasing, clear and full. Male opera singers are particularly favored with 5 kHz sounds, women less so. In popular music, this range shifts downward somewhat. It follows that voices deficient in the 5 kHz range can be enhanced in listening value by a generous boost on the order of 5 to 8 dB at 5 kHz. A secondary benefit of this boost is an apparent increase in level; a 6 dB rise at 5 kHz frequently gives an apparent increase of 3 dB to the overall signal.*

*Attenuating the 5 kHz range on instruments gives a "transparent" quality to the sound, providing, of course, that the remainder of the signal is otherwise wide range. Microphones having a dip in this region lack the "punch" or "presence" to which we (Americans) are accustomed.*

### **2.2.7 Brilliance**

*Unvoiced consonants attributed to tooth, tongue and lip sounds are high in frequency, and reach the 10 kHz range. These frequencies account for some clarity and most brilliance, even though they contain less than 2% of the total speech energy. This also holds true for musical instruments; especially percussion. Boosting or cutting this range affects clarity and naturalness. In speech, the 9th and 10th octaves impart intimacy although too much emphasis can make secondary speech sounds (lip smacking, etc.) objectionable (a good case for a expander).*

*Some microphones having a rise at the higher frequencies (especially omni microphones) benefit from some attenuation in this region. Those microphones having under damped diaphragms may ring at these frequencies, causing an annoying sibilant distortion on speech. On musical forms using hand percussion, boosting this range frequently results in an astonishing and pleasing feeling of clarity.*

### **2.2.8 Conclusions**

When the article containing the above excerpts was written (probably around 1963), stereo was just becoming a commercial reality (you could still purchase mono and stereo versions of an LP and there were still more FM stations broadcasting in mono than stereo), and as many mixers contained rotary mix pots as those that used slide pots. The value of individual channel equalization was known, but it was both technologically and financially prohibitive. The article concludes thusly:

*"With the advent of stereo and three-channel recording, nearly three times the equipment, with more elaboration, seems indicated, and expansion of console area in the horizontal plane offers the only direction in which to proceed. But a single engineer has arms only so long."*

How times have changed!

### **2.2.9 Using the Parametric Equalizer**

Great care must be exercised when using equalization. The following paragraphs give some general hints and precautions for using the 528E's parametric equalizer (or any other equalizer, for that matter).

### **2.2.10 Beware of Distortion and Noise**

When a frequency or group of frequencies are boosted, the overall operating level is boosted as well. For example, 12 dB of boost (no matter what the frequency) increases the 528E's output level 12 dB (at that frequency). This kind of boost reduces headroom by 12 dB in every circuit from the 528E's own line driver to the last device in the signal chain (transmitter, tape machine, or what have you). Unless signal levels are very low to begin with, the 528E's output gain will have to be reduced to compensate for increased levels whenever the equalizer is used for boost.

The CLIP LED in the OUTPUT LED meter monitors levels in the equalizer as well as at the output of the 528E. If the CLIP LED glows, try switching the equalizer to BYPASS. If the LED still glows, reduce the setting of the OUTPUT GAIN control. If switching the equalizer to BYPASS eliminates the clip indication, then the input level must be reduced via the MIC GAIN control or by lowering the level of the line input.

On the other hand, if the levels within the 528E are too low to start with, using the equalizer for boost may increase noise to unacceptable levels.

If levels are too low, increase the preamp gain (or the output level of the device feeding the line input).

### **2.2.11 Know What You Are Listening To**

Low frequency boost may increase the level of some frequencies that cannot be heard, for one reason or another. Many high quality microphones are capable of generating substantial output at very low frequencies (below 50 Hz) which cannot be adequately reproduced by most monitor speakers or headphones. Be aware that the true effects of low frequency boost may not be audible, and may actually result in a "muddy" or distorted sound.

### **2.2.12 Use Wide Peaks, Narrow Dips**

In general, the human ear prefers wide bandwidth peaks and narrow bandwidth dips. Boosting a narrow bandwidth produces a sound usually perceived as "offensive," while boosting wider bandwidths (.7 octave or greater) usually results in a sound deemed "musical." It has also been observed that very few people will notice anything's missing when a narrow bandwidth (.3 octave or less) is cut, even when it's cut as much as 30 dB. But, cut a wide bandwidth and the resulting sound quality is often called "empty."

### **2.2.13 Tuning the EQ/Notch Filter**

To "tune" the equalizer, use full boost. For both boost and cut, the 528E's parametric equalizer is intended to be put to work on specific frequencies. To find a particular frequency "by ear" (the method used by everyone who doesn't have a real-time analyzer), turn the cut/boost control all the way up to +15 dB (be very careful of feedback if you are monitoring on a loudspeaker!). Set the bandwidth for about .3 octave (max CCW). Tune the frequency control until you distinctly hear the part of the sound you wish to control. Then, adjust the cut/boost control for the appropriate amount of change, and readjust the bandwidth control if necessary.

## 2.2.14 Equalizing for Speech

In broadcast, equalizers are often used to create a sonic personality for the station's on-air talent. In production applications, it is practical to write down each person's settings. In broadcast applications (on-air), most stations try to find a single composite setting that works for all of their on-air talent. If your station's on-air talent is comprised of both men and women then finding a single, compromise setting becomes more difficult. A possibly more workable solution might be to use a single-D<sup>3</sup> microphone (so it has proximity effect) and to vary the working distance to alter the low-frequency response somewhat.

Some general thoughts on speech equalization:

1. Try to use wider bandwidths. Narrower bandwidths (1/2 octave and less) are less audible (harder to hear) and are generally only useful for remedial work. Broader bandwidths are less obnoxious, more pleasing sounding, and easier to work with (especially if you're boosting a range of frequencies).
2. Try to avoid massive amounts of boost or cut. If you're only trying to impart a flavor (like sprinkling salt and pepper on a meal), then 6-8 dB of boost or cut should be all that you need.
3. A wide bandwidth cut is equivalent to a boost at the frequencies surrounding the cut.
4. A quick way to figure out what's going on is to set the level of one band of the equalizer to full boost (+15 dB), then switch to the frequency control and vary the frequency of that band of the equalizer while listening to program material fed through the unit. This usually makes quick work out of finding the region that you want to work on. Now reduce the level setting to something tasteful.

A common problem when trying to set an equalizer for someone's voice is converting the descriptive adjectives that people use in describing the character of a voice into the numbers that make equalizers happy. Figure 2-1 lists some commonly used adjectives and their corresponding frequency ranges.

Range	Description (men)	Range	Description (women)
75-200 Hz	"Balls", rumble, heaviness	100-250 Hz	Fullness
200-300 Hz	Bassiness, bigness	250-400 Hz	Bassiness, bigness
400-600 Hz	Chesty	400-600 Hz	Warmth
600-1 kHz	Volume	600-1 kHz	Volume
2 kHz-4 kHz	Clarity	2 kHz-4 kHz	Clarity
3 kHz	Nasal, yell, presence	3 kHz - 5 kHz	Nasal, yell, presence
5 kHz-8 kHz	Enunciation, intimacy	5 kHz-8 kHz	Enunciation, intimacy
10 kHz up	Air, mouth noises	10 kHz up	Air, mouth noises

Figure 2-1. Descriptive adjectives for voice ranges of men and women.

To tailor your station's announce sound, begin with an idea of what general sound you want. Since you only have three general locations that you can equalize at, you'll need to begin with the aspects of your sound that are most important. The choice of microphone is very important, since every microphone imparts its own equalization to any sound that it hears. If you want a large, "ballsy" sound, you ought to think about single-D cardioid microphones such as those made by AKG, Shure, Neumann, Sennheiser, and EV (like the RE38N/D or ND series) or a ribbon microphone such as the RCA 77DX. The built-in bass boost caused by close talking a single-D microphone (proximity effect) can be tailored or tamed with careful

<sup>3</sup>A single-D microphone is a directional microphone having its rear-entry port(s) spaced at a single distance from the diaphragm. Single-D microphones are always characterized by proximity effect, a rise in the bass response at short working distances.

equalization, which also reduces room rumble at the same time. Last, since the proximity effect increases with decreasing source-microphone distance, a skilled user can substantially change their sound simply by moving in or out from the microphone.

If clarity is your goal, then a variable-D<sup>4</sup> microphone such as the EV RE-20, RE-27 or RE-18 or an omnidirectional type such as the EV RE50 or AKG414 (with the pattern set to omni) is a good choice as these types do not emphasize the bass frequencies when you close-talk them. On the negative side, any room rumble present with the microphone will be boosted along with the voice if you try to equalize at the lower frequencies.

Next, add or remove low frequencies in the 100-300 Hz range until you get a weight or fullness that is pleasing. Next add midrange boost in the 2.5 kHz to 5 kHz range to add punch and presence (experiment with the bandwidth control!), and finally add or remove frequencies in the 10000+ Hz range to get the sense of brilliance that you want.

The chart shown in Figure 2-2 shows the relationships of many different instruments, and a piano keyboard along with the frequencies involved.

---

<sup>4</sup>A variable-D cardioid microphone has multiple rear entry ports spaced at varying distances from its diaphragm. Variable-D microphones have little or no proximity effect. Variable-D is a trademark of Electro-Voice Inc.

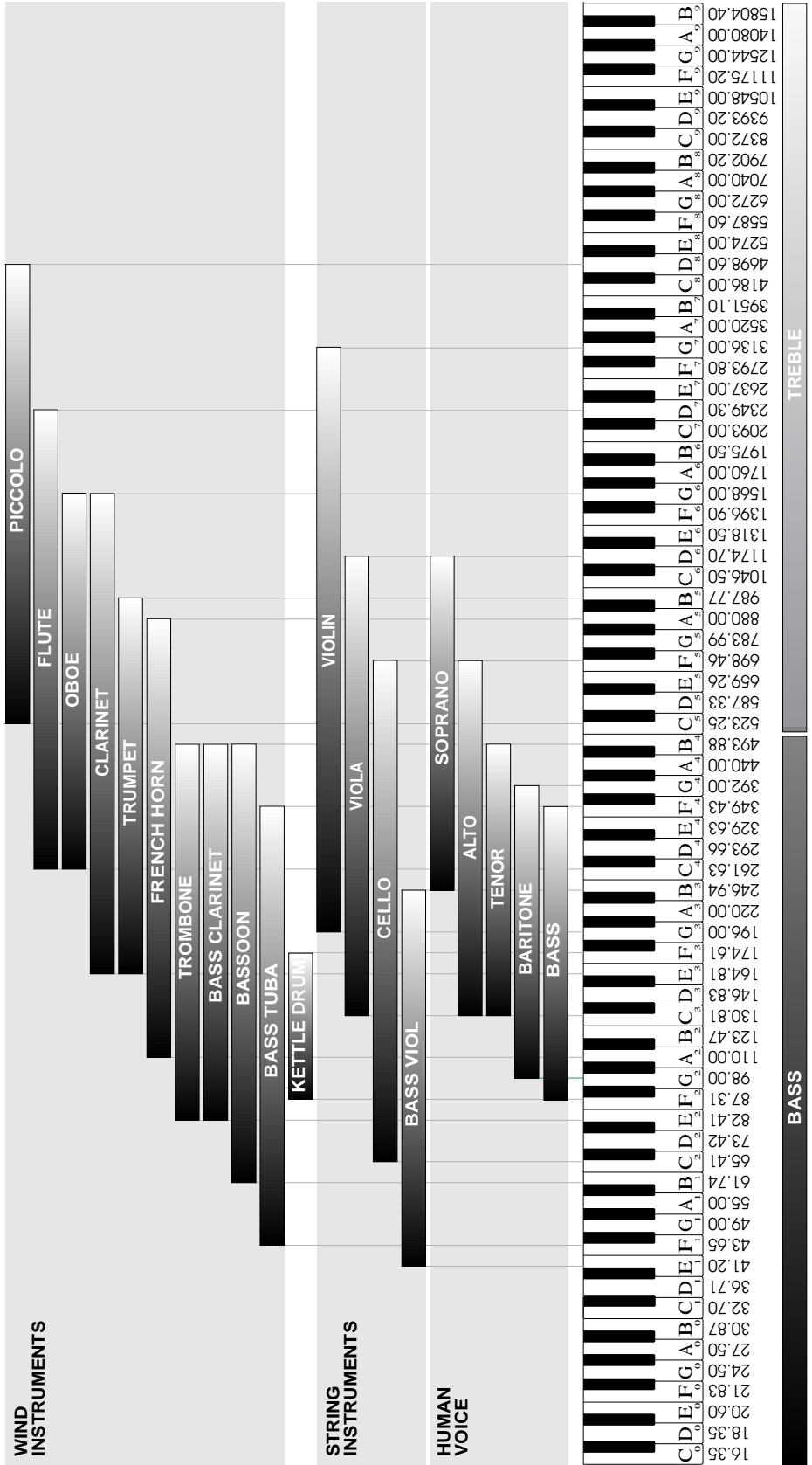

Figure 2-2. Relationships of Musical instruments, Piano, and actual frequencies.



### 3. Technical Tutorial

This section discusses a multitude of things, all related to getting signals in and out of the 528E.

#### 3.1 Matching Levels vs Matching Impedances

In any audio equipment application, the question of "matching" inevitably comes up. Without digging a hole any deeper than absolutely necessary, we offer the following discussion to (hopefully) clarify your understanding of the subject.

Over the years, we have all had impedance matching pounded into our heads. This is important only for ancient audio systems, power amplifiers, and RF. Technically speaking, the reason is power transfer, which reaches a maximum when source and load are matched. Modern audio systems are voltage transmission systems and source and load matching is not only unnecessary, but undesirable as well.

- ❑ Ancient audio systems operate at 600 ohms (or some other impedance value), and must be matched, both at their inputs and at their outputs. Generally speaking, if you are dealing with equipment that uses vacuum tubes, or was designed prior to 1970, you should be concerned about matching. These units were designed when audio systems were based on maximum power transfer, hence the need for input/output matching.
- ❑ Power amplifiers are fussy because an abnormally low load impedance generally means a visit to the amp hospital. Thus, it's important to know what the total impedance of the pile of speakers connected to the amplifier really is.
- ❑ RF systems are matched because we really are concerned with maximum power transfer and with matching the impedance of the transmission line (keeps nasty things from happening). Video signals (composite, baseband, or otherwise) should be treated like RF.

Some folks seem to believe that balanced/unbalanced lines and impedances are related; or even worse that they are associated with a particular type of connector. Not so. Unbalanced signals are not necessarily high-impedance and balanced signals/lines are not necessarily low-impedance. Similarly, although 1/4-inch jacks are typically used for things like guitars (which are high-impedance and unbalanced), this does not predispose them to only this usage. After all, 1/4 inch jacks are sometimes used for loudspeakers, which are anything but high-impedance. Therefore, the presence of 3-pin XLR connectors should not be construed to mean that the input or output is low-impedance (or high-impedance). The same applies to 1/4-inch jacks.

So, what is really important? Signal level, and (to a much lesser degree), the impedance relation between an output (signal source) and the input that it connects to (signal receiver).

Signal level is very important. Mismatch causes either loss of headroom or loss of signal-to-noise ratio. Thus, microphone inputs should only see signals originating from a microphone, a direct (DI) box, or an output designated microphone-level output. Electrically, this is in the range of approximately -70 to -20 dBm. Line inputs should only see signals in the -10 to +24 dBm/dBu range. Guitars, high-impedance microphones, and many electronic keyboards do not qualify as line-level sources.

The impedance relation between outputs and inputs needs to be considered, but only in the following way:

**Always make sure that a device's input impedance is higher than the output source impedance of the device that drives it.**

Some manufacturers state a relatively high-impedance figure as the output impedance of their equipment. What they really mean is that this is the minimum load impedance that they would like their gear to see. In most cases, seeing a output impedance figure of 10,000 (10K) ohms or higher from modern equipment that requires power (batteries or AC) is an instance of

this type of rating. If so, then the input impedance of the succeeding input must be equal to or greater than the output impedance of the driving device.

Symetrix equipment inputs are designed to bridge (be greater than 10 times the actual source impedance) the output of whatever device drives the input. Symetrix equipment outputs are designed to drive 600-ohm or higher loads (600-ohm loads are an archaic practice that won't go away). You don't need to terminate the output with a 600-ohm resistor if you aren't driving a 600-ohm load. If you don't understand the concept of termination, you probably don't need to anyway.

The two facts that you need to derive from this discussion are:

1. Match signal levels for best headroom and signal-to-noise ratio.
2. For audio, impedance matching is only needed for antique equipment and power amplifier outputs. In all other cases, ensure that your inputs bridge (are in the range of 2 to 200 times the output source impedance) your outputs.

## 3.2 Signal Levels

The 528E is designed around studio/professional line levels: +4 dBu or 1.23 volts. The unit is quiet enough to operate at lower signal levels such as those found in semi-pro or musical-instrument (MI) equipment (-10 dBu or 300 millivolts).

The microphone input is designed to accept low-impedance microphones. Switchable 48V phantom powering is provided for suitable condenser microphones. The microphone input accepts signal levels from -60 to -5 dBV (+10 dBV with the -15 dB pad).

The line input is designed to accept nominal line level: +4 dBu.

The output line driver delivers +4 dBm into 600-ohm or higher balanced loads. An internal switch converts the line level output to microphone level, or -36 dBu. Refer to Appendix C.

An unbalanced output is also available via a 1/4" TRS phone jack. This jack is always line-level and is unaffected by the internal switch.

## 3.3 I/O Impedances

The 528E is designed to interface into almost any recording studio or sound reinforcement application. This includes:

- 600 ohm systems where input and output impedances are matched.
- Unbalanced semi-professional equipment applications.
- Modern bridging systems where inputs bridge and outputs are low source impedances (voltage transmission systems).

The 528E's microphone input is intended to bridge a 150-ohm balanced source. The actual input impedance is approximately 8-kilohms. 48V phantom powering for condenser microphones is present if the PHANTOM POWER switch has been depressed. Refer to section 3.6 for additional information.

The 528E's line input impedance is **10-kilohms** balanced, and **10-kilohms** unbalanced. The inputs may be driven from any source (balanced or unbalanced) capable of delivering at least -10 dBu into the aforementioned impedances.

The 528E's output impedance is **200 ohms** balanced, **100 ohms** unbalanced. The output line driver delivers **+18 dBm into a 600-ohm** balanced load or **+18 dBm into 600-ohm unbalanced** loads.



### 3.4 Polarity Convention

The 528E uses the international standard polarity convention of pin 2 hot. Therefore:

XLR	Tip-Ring-Sleeve	Signal
1	Sleeve	Ground
2	Tip	High
3	Ring	Low

If your system uses balanced inputs and outputs, and uses the 528E this way, then the polarity convention is unimportant. If your system is both balanced and unbalanced, then you must pay attention to this, especially when going in and coming out through different connector types (like input on an XLR, output on a phone jack).

### 3.5 Input and Output Connections

Figure 3-1 illustrates how to connect the 528E to balanced and unbalanced sources and loads.

To operate the 528E from line level unbalanced sources, run a 2-conductor shielded cable (that's two conductors plus the shield) from the source to the 528E's line input. At the source, connect the low/minus side to the shield, these connect to the source's ground; connect the high/plus side to the source's signal connection. At the 528E, the high/plus wire connects to pin 2, the low/minus wire connects to pin 3, and the shield (always) connects to pin 1. This is the preferred method as it makes best use of the 528E's balanced input (even though the source is unbalanced). The other alternative shown in Figure 3-1 converts the 528E's balanced input into an unbalanced input at the input connector. This works, but is more susceptible to hum and buzz than the preferred method. There is no level difference between either method.

The 528E has two output connectors: XLR-male and TRS female. The XLR connector may be configured for either microphone-level or line-level output. The TRS connector is always line level. Refer to Appendix B for conversion instructions.

You can drive unbalanced loads with the 528E's outputs by using the XLR connector with pin 3 left open. In an emergency (the show must go on), you can ground pin 3, but if you have the choice...leave it open. If you must ground pin 3, it must be grounded at the 528E, rather than at the other end of the cable. The price, regardless of whether or not pin 3 is grounded is 6dB less output level. This can be easily made up via the output gain controls. If your system is wired with pin 3 hot, **pin 2 must float** if you are driving an unbalanced load.

The 1/4-inch unbalanced output uses a TRS female jack with the ring contact wired to circuit ground. This jack is unaffected by the internal output level switch. Unlike the XLR connector, using this jack corrects the gain so that it is unity.

The interstage patching jacks are half-normalled (only the input jack breaks normal) TRS jacks wired for unbalanced operation. This means that the tip is the signal connection, ring and sleeve are ground. This method of connection allows either TRS or TS plugs to be used, with either balanced or unbalanced inputs or output on the remote equipment. Aside from that, the TRS jack grabs the plug better. Ensure that your plug is fully inserted into the jack.

The sidechain access jack for the dynamics processor uses a TRS jack wired as an insert jack. This means that the ring connection is the send to and the tip connection is the return from the remote processor. Figure 3-2 shows the wiring for the plug as well as the connections to/from the external processor.

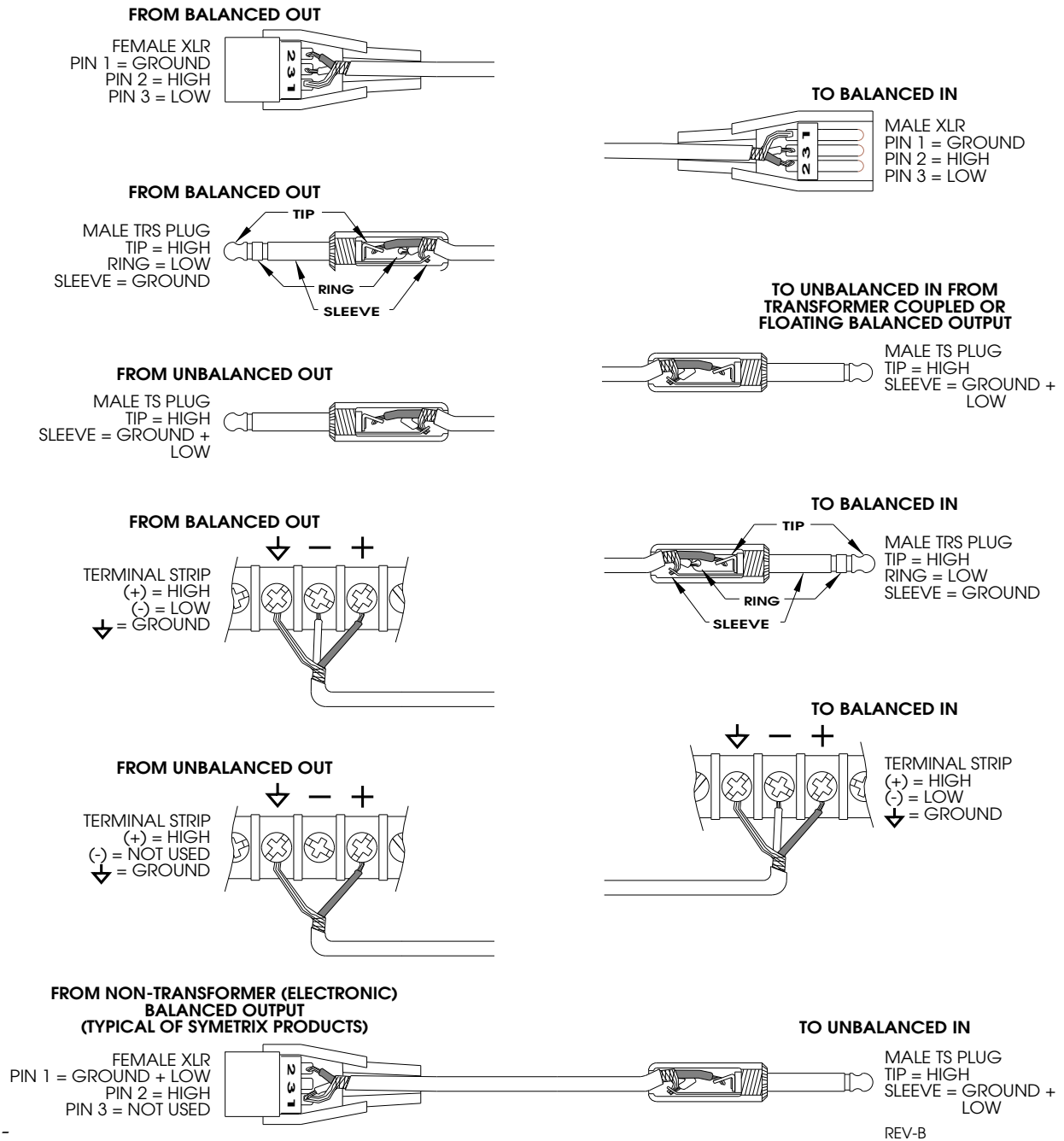

**Figure 3-1. Input and output connector wiring. These diagrams represent the majority of connectors used in modern audio equipment. Locate the source connector in the left column and match it up with the destination connector in the right column. Wire your cable according to the diagrams.**

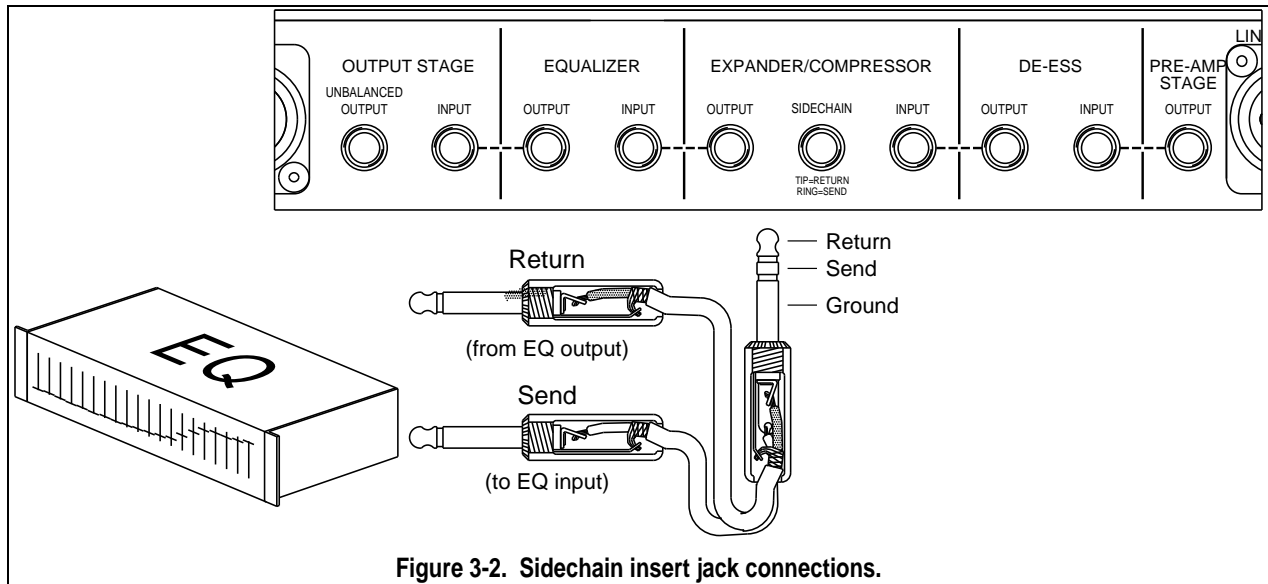

Figure 3-2. Sidechain insert jack connections.

### 3.6 Phantom Powering Condenser Microphones

Most modern condenser microphones have provisions for being remotely powered via the microphone cable. The dominant system in use today is the phantom power system which is compatible with both condenser and non-condenser microphones (dynamics, ribbons, etc.). If your microphone's data sheet says that it is phantom powered, the 528E can power it<sup>1</sup>.





Another remote powering system exists called A-B powering, modulation lead powering, or T system. A-B powering is incompatible with phantom powering as well as other non-powered microphones.

The technical requirements for operation and/or compatibility are:

- ❑ The microphone must have a balanced, low-impedance output.
- ❑ The balanced output must be floating with respect to ground. If there is a center tap, it must also float with respect to ground. (In the past, it was common to ground the center tap of the microphone's output transformer. This was especially true of ribbon microphones.)

<sup>1</sup> The DIN specification (DIN 45 596) covering phantom powering specifies the phantom powering voltage as an open-circuit measurement. If you attempt to measure the phantom voltage, **make sure that you do so with the microphone disconnected.**

In a nutshell, here are the do's and don'ts of phantom powering.

Do	Don't
Verify that your microphone can be phantom powered (only if it is a condenser mic).	Worry about your dynamic or ribbon microphones, as long as they are wired so that the output is balanced and floating.
Ensure that your microphone's output is low impedance, <b>balanced and floating</b> . This is especially important for ribbon mics like the RCA 77DX and 44BX.	 Plug in an A-B powered microphone without a suitable adapter.
 Mute your monitor speakers or headphones when turning the phantom power on or off. If you don't, there <b>will be a loud, nasty POP</b> . <sup>2</sup>	Use the microphone input with unbalanced sources. Use a direct box to feed an unbalanced source into the microphone input.
 Mute your monitor speakers or headphones whenever you plug or unplug a phantom powered microphone. If you don't, there <b>will be a loud, nasty POP</b> .	Worry about your tube condenser mics. They're compatible (although they can't be phantom powered).
Turn the phantom power off when connecting vintage ribbon microphones.	 Use the microphone input for line-level sources, especially those that are transformerless.

---

<sup>2</sup> The 528E mutes its output whenever the phantom power switch is actuated, which prevents the loud, nasty pop...BUT other pieces of equipment probably don't mute their outputs when their phantom power switches are actuated. Muting the monitors or phones is a good habit to get into regardless.

## 4. Front Panel Overview

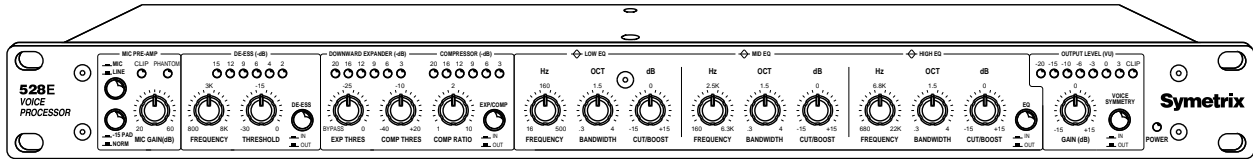

### Mic Preamp

MIC/LINE Switch	Selects between the Mic input (switch in) and Line input (switch out).
-15 dB PAD Switch	Inserts 15 dB pad for strong mic signals.
MIC GAIN	Sets the gain of the mic preamp for best compromise between signal-to-noise ratio and headroom.
CLIP LED	Monitors inputs (mic and line) for clipping. Illuminates 3 dB below the actual clip point.
PHANTOM LED	Illuminates when 48V phantom power is present at the microphone input connector. The phantom power switch is located on the rear panel.

### DE-Esser

FREQUENCY	Sets the rolloff (cutoff) frequency of the de-esser.
THRESHOLD	Sets the threshold level for the de-esser. Signals above this level cause de-esser action, signals below do not.
IN/OUT Switch	Hard-wire bypasses the de-esser. The de-esser is active when this switch is <b>in</b> .
LED Display	Indicates the amount of de-esser activity at any instant in time.

### Downward Expander / Compressor

EXP THRESH	Sets the threshold level for the downward expander. Signals below this threshold are downward expanded (reduced in level).
COMP THRESH	Sets the threshold level for the compressor. Signals above this threshold cause gain reduction in the compressor.
COMP RATIO	Sets the compression ratio of the compressor.
EXP/COMP IN/OUT Switch	Defeats the downward expander / compressor. This is <b>not</b> a hard-wire bypass.
DOWNWARD EXPANDER LED Display	Indicates the amount of downward expander activity (gain reduction) at any instant in time.
COMPRESSOR LED Display	Indicates the amount of compressor activity (gain reduction) at any instant in time.

### **Parametric EQ Low**

FREQUENCY	Varies the center frequency of the low-frequency equalizer from 16 Hz to 500 Hz.
BANDWIDTH	Varies the bandwidth of the low-frequency equalizer from 0.3 to 4 octaves. ( $Q=4.8$ to $0.27$ ).
CUT/BOOST	Sets the degree of boost or cut; $\pm 15$ dB.

### **Parametric EQ Mid**

FREQUENCY	Varies the center frequency of the low-frequency equalizer from 160 Hz to 6300 Hz.
BANDWIDTH	Varies the bandwidth of the low-frequency equalizer from 0.3 to 4 octaves. ( $Q=4.8$ to $0.27$ ).
CUT/BOOST	Sets the degree of boost or cut; $\pm 15$ dB.

### **Parametric EQ High**

FREQUENCY	Varies the center frequency of the low-frequency equalizer from 680 Hz to 22 kHz.
BANDWIDTH	Varies the bandwidth of the low-frequency equalizer from 0.3 to 4 octaves. ( $Q=4.8$ to $0.27$ ).
CUT/BOOST	Sets the degree of boost or cut; $\pm 15$ dB.
IN/OUT Switch	Hard-wire bypasses the entire equalizer.

### **Output Section**

GAIN	Sets the overall gain of the 528E'S output over a $\pm 15$ dB range. Note: the actual adjustment point is in the expander/compressor's VCA, which is pre-EQ.
VOICE SYMMETRY Switch	Inserts speech waveform asymmetry correction into the signal path.
OUTPUT LED Display	Indicates the peak output level of the 528E relative to the balanced output. 0 VU on the display corresponds to +4 dBu at the balanced output. For unbalanced applications, the actual output level is 6 dB lower than that shown by the display.  Note: if the internal mic-level output switch has been depressed, the output level is -40 dBu when the display indicates 0 VU.
Power LED	Indicates the presence of AC power.

## 5. Rear Panel Overview

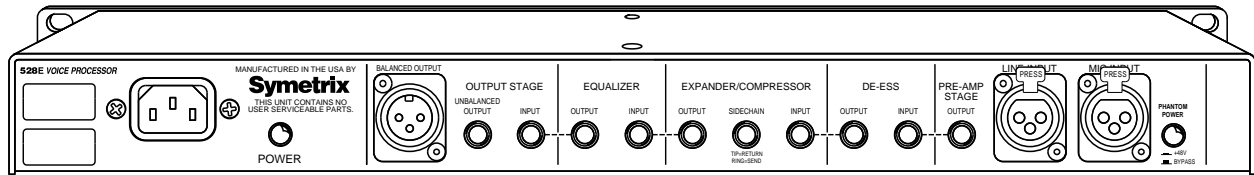

Serial Number	Do yourself a favor and write this number down somewhere safe, and while you're at it, please send us the completed warranty card?
AC Power Input	IEC-power connector. Connect only to appropriate AC power source. Refer to rear-panel marking for correct AC source voltage.
OUTPUTS	XLR-male, balanced, line-level output. This output may be converted to mic-level via an internal switch. Refer to Appendix C. TRS phone jack (wired unbalanced). This is the unbalanced, line-level output of the 528E. This jack is unaffected by the internal switch (see preceding paragraph).
OUTPUT STAGE INPUT	TRS phone jack (wired for unbalanced operation). This is the input to the output stage and interrupts the signal coming from the remainder of the 528E.
EQUALIZER OUTPUT	TRS phone jack (wired unbalanced). This is the output of the equalizer. This jack does <b>not</b> interrupt the signal flow to the 528E's output stage.
EQUALIZER INPUT	TRS phone jack (wired unbalanced). This is the input to the equalizer. This jack interrupts the signal from the Expander/Compressor.
EXPANDER/COMPRESSOR OUTPUT	TRS phone jack (wired unbalanced). This is the output of the Expander/Compressor. This jack does not interrupt the signal flow to the 528E's equalizer.
EXPANDER/COMPRESSOR SIDECHAIN	TRS phone jack wired as an insert jack (Tip=return, Ring=send). Use this jack to access the compressor/expander's sidechain.
EXPANDER/COMPRESSOR INPUT	TRS phone jack (wired unbalanced). This is the input to the Expander/Compressor. This jack interrupts the signal from the De-Esser.
DE-ESS OUTPUT	TRS phone jack (wired unbalanced). This is the output of the De-Esser. This jack does not interrupt the signal flow to the 528E's Expander/Compressor.
DE-ESS INPUT	TRS phone jack (wired unbalanced). This is the input to the De-Esser. This jack interrupts the signal from the Mic/Line inputs.
PRE-AMP STAGE OUTPUT	TRS phone jack (wired unbalanced). This is the output of the Mic/Line preamp. This jack does not interrupt the signal flow to the 528E's De-Esser.

LINE INPUT	XLR Connector. 10-kilohm balanced bridging line input intended for signals ranging from -10 dBu to +4 dBu.
MIC INPUT	XLR connector. Balanced input suitable for low-impedance microphones. 48V phantom powering available.
PHANTOM POWER	Supplies 48V phantom powering to the microphone input. A LED located on the front panel indicates the presence of phantom power when illuminated. The 528E's outputs temporarily mute anytime that this switch is operated. Refer to Chapter 3 for additional information on phantom powering.



## 6. Fast First Time Setup

Follow these instructions to get your 528E up-and-running as quickly as possible. The intent of this section is fast setup. If you need something clarified, then you'll find the answer elsewhere in this manual.

### 6.1 Connections

Connect your input source to the appropriate XLR connector. Connect the 528E's output to line-level input using the XLR output connector. If you need to feed a mic-level input, refer to Appendix C before proceeding further. Ignore the interstage patching for now (details in Chapter 7 and 8).

If you are using a condenser microphone, refer to "Phantom Powering Condenser Microphones" in Chapter 3 before depressing the PHANTOM POWER switch.

Connect the AC input to an AC power source of the proper voltage and frequency, as marked on the rear of the unit.



**Caution:** *Failure to connect the 528E to the proper AC mains voltage may cause fire and/or internal damage. There are no user serviceable parts inside the chassis. Refer all service to qualified service personnel or to the factory.*

**Warning:** **Lethal voltages are present inside the chassis. There are no user serviceable parts inside the chassis. Refer all service to qualified service personnel or to the factory.**

### 6.2 Settings

Set the controls and switches on the front and rear panel as follows:

Front Panel Control	Setting	Front Panel Control	Setting	Rear Panel	Setting
MIC/LINE	as reqd.	EQ Low FREQUENCY	0 (12:00 o'clock)	Output	Connect to input of console, tape recorder, etc.
-15 DB PAD	OUT	EQ Low BANDWIDTH	1.5 octaves	Line Input	Connect line-level source here.
MIC GAIN	12:00 o'clock	EQ Low CUT/BOOST	0 (12:00 o'clock)	Mic Input	Connect microphone here.
De Esser FREQUENCY	12:00 o'clock	EQ Mid FREQUENCY	12:00 o'clock	Phantom Power	Depress if mic requires phantom powering.
De-Ess THRESHOLD	0 (max CW)	EQ Mid BANDWIDTH	1.5 octaves		
DE-ESS IN/OUT	IN	EQ Mid CUT/BOOST	12:00 o'clock		

*(table continued on next page)*

Front Panel Control	Setting	Front Panel Control	Setting
Expander THRESHOLD	0 (max CW)	EQ High FREQUENCY	11:00 o'clock
Compressor Threshold	-10 (12:00 o'clock)	EQ High BANDWIDTH	1.5 octaves
Compressor RATIO	2:1 (12:00 o'clock)	EQ High CUT/BOOST	0 (12:00 o'clock)
EXP/COMP switch	IN	EQ IN/OUT	IN
VOICE SYMMETRY switch	OUT	GAIN	0 (12:00 o'clock)

### 6.3 Initial Setup

The 528E's controls and switches are now set according to the preceding section. All connections listed in Section 6.1 are now made. The 528E should now pass signal. The OUTPUT LEVEL LED display and the POWER LED should be illuminated. Depending upon the signal levels, the compressor's gain-reduction display may be illuminated.

### 6.4 Refining Your Settings

At this point, the 528E should pass signal. There should be some activity on some of the LED displays.

#### 6.4.1 Mic Preamp Gain

Temporarily put the De-esser, Exp/Comp, and EQ sections into bypass mode, set the MIC GAIN control so that the OUTPUT LED display indicates a signal level between -10 and 0 VU. The CLIP LED should almost never illuminate.

#### 6.4.2 De-Esser Settings

Use the de-esser to reduce the level of sibilant sounds (S and T sounds) if they are objectionable. Set the THRESHOLD control so that the de-esser gain-reduction display shows about 12 dB of gain-reduction. Now "tune" the FREQUENCY control for maximum sibilance reduction. Finally, reduce the setting of the THRESHOLD control until you reduce the sibilance to a tolerable level. Try to use the lowest setting of the FREQUENCY control that gets the job done.

#### 6.4.3 Downward Expander Settings

Use the downward expander to reduce room noise and/or mouth noises. Set the THRESHOLD control to allow low level speech sounds to pass while still blocking the room sound.

#### 6.4.4 Compressor Settings

Use the threshold control to vary the amount of gain reduction, as indicated on the compressor's gain-reduction display. Generally, 3 to 6 dB is sufficient, unless you are using a low compression ratio (below 2:1), or you want a special effect. Pick a ratio suited to the task at hand: low ratios and low thresholds for unobtrusive level control, medium ratios for overall level control and consistency, high ratios (> 8:1) for limiting or in-your-face sorts of sounds.

## 6.4.5 Equalizer Settings

The settings given will work well with male voices. For women, the low-EQ range shifts up to 200 or 300Hz, the mid-EQ range shifts up to 3-5 kHz.

If you are using a microphone that exhibits proximity effect when you close-talk it, then you'll probably need to reduce (cut) the bass (low) response somewhat. 3-6 dB should be fine (don't do this if you want a big, ballsy sound). A bit of mid-EQ will help make voices cut and seem loud. The high-EQ adds brightness and intimacy.

If you are using a microphone that has no proximity effect (like the ElectroVoice RE-20), then you'll probably need to increase (boost) the bass response somewhat. 3 to 6 dB should do the job. The same mid- and high- EQ recommendations given previously still apply. A thorough discussion of equalization may be found in Chapter 2.

## 6.4.6 Output Settings

For many applications, setting the output GAIN control at 0 dB (12:00 o'clock) works fine. If you are adding a bunch of EQ (which tends to cause an overall level increase), then you may need to decrease the GAIN setting. On the other hand, if you are using a fair amount of compression, you may need to add some gain to compensate for the level lost in compression. Pick a setting that gives you enough signal downstream, yet still keeps the CLIP LED from illuminating. The output display is peak responding, so you can't quite set levels as if it were a VU meter.

The output CLIP LED monitors both the equalizer and the output stage. Large amounts of boost and/or high signal levels can cause CLIP indications. If this occurs, lower the signal level via the GAIN control. It is also possible for the output stage to clip if a processor, inserted via the output stage access jacks, is contributing gain to the overall signal path. In this case, either lower the gain of the insert processor or reduce the setting of the GAIN control.



## 7. Using the 528E

This section is intended for more advanced users. If you are a first-time user, we recommend that you start out by using the procedure found in "Fast, First-Time Setup."

### 7.1 Block Diagram

Figure 7-1 is the block diagram for the 528E. Please take a moment and take note of the following:

- ❑ The equalizer and de-esser are hard-wire bypassed by their IN/OUT switches.
- ❑ The interstage patch points use TRS jacks wired for unbalanced operation.
- ❑ The interstage patch points are half-normalled. The send jack does not break the signal flow.
- ❑ The output level of the 528E can be set to either line level or mic level. The switch for this function is internal to the unit. Refer to Appendix B.

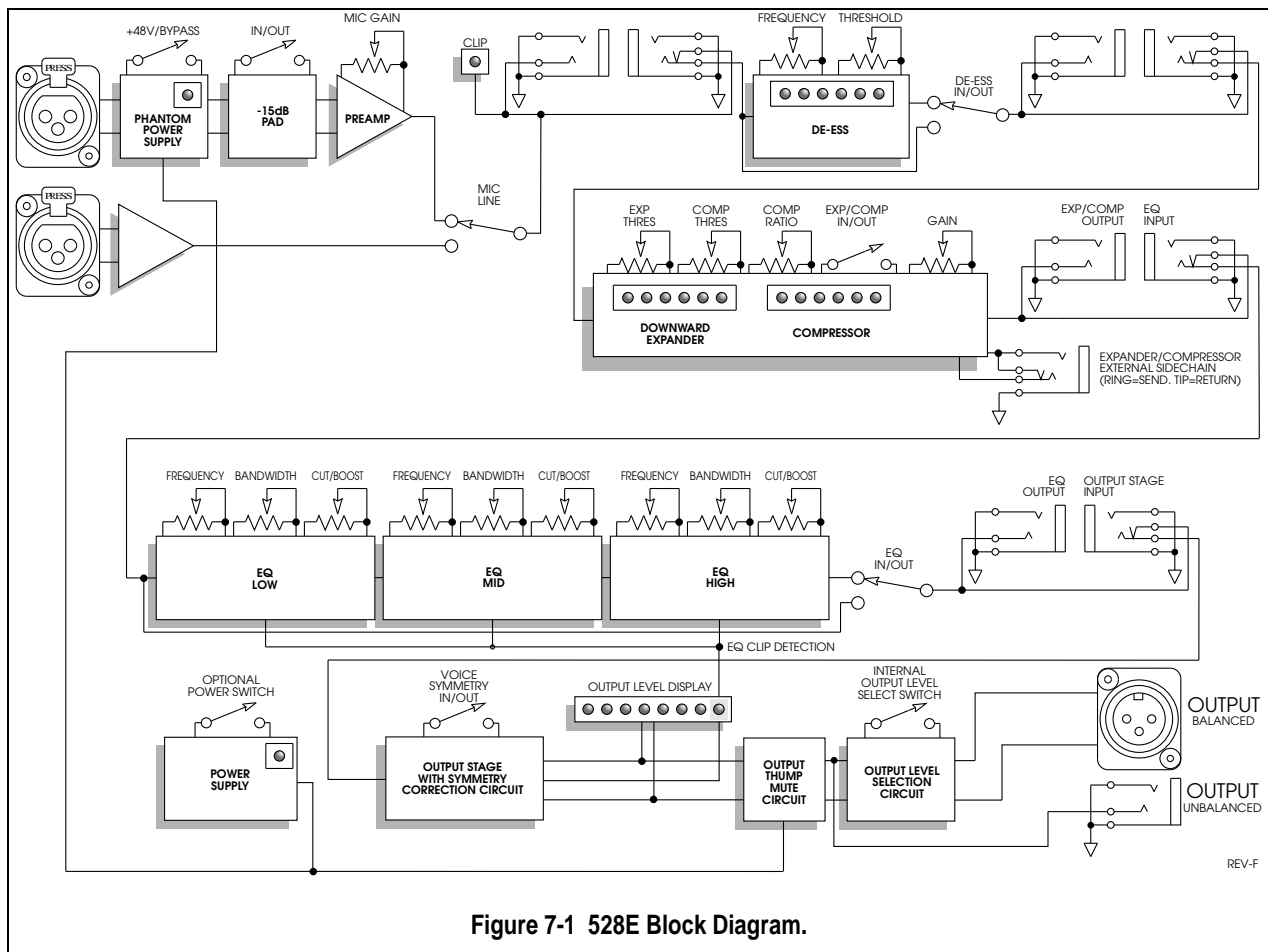

Figure 7-1 528E Block Diagram.

## 7.2 Installation

The **528E** may be installed free-standing or rack mounted. Rubber feet are included for free-standing use. No special ventilation requirements are necessary. Table 7-1 lists the 528E's requirements for installation.

<b>Table 7-1. Installation Requirements</b>	
Mechanical	One rack space (1.75 inches) required, 12.5 inches depth (including connector allowance). Rear chassis support recommended for road applications.
Electrical	105-125V ac, <b>12.5 Watts maximum</b> . 210-250V ac, 50 Hz, 12.5W maximum (export).
Connectors	XLR-3 female for inputs, XLR-3 male and TRS 1/4-inch female for outputs, Pin 2 of the XLR connectors is "Hot."  The sidechain access jack output uses a TRS jack wired as an insert jack (tip=return, ring=send).  The interstage patch points use TRS jacks with the ring and sleeve connections connected to circuit ground. The jacks are half-normalled (only input breaks normal).

## 7.3 Level Setting

For optimum noise performance, correct level settings are a must, especially for microphone sources. You should operate the 528E's mic preamp at the highest gain possible without overload. Extremely hot signals may require using the -15 dB pad switch.

The 528E expects line level signals to fall in the +4 dBu region. Lower signal levels are okay, but the noise performance may suffer as there is no gain trim control for the line input.

The CLIP LED in the mic input section of the 528E actually monitors the output of the MIC-LINE switch. If the LED glows, and you are using the MIC input, then reduce the setting of the MIC GAIN control until the LED no longer glows. If you are using the LINE input, reduce the level of the device driving the 528E.

The CLIP LED in the OUTPUT LED meter monitors levels in the equalizer as well as at the output of the 528E. If the CLIP LED glows, try switching the equalizer to BYPASS. If the LED still glows, reduce the setting of the OUTPUT GAIN control. If switching the equalizer to BYPASS eliminates the clip indication, then the input level must be reduced via the MIC GAIN control or by lowering the level of the line input.

## 7.4 Operational Details

This section describes the details of operating the 528E. Usage information can be found later in this chapter.

The 528E accepts monaural analog input signals at mic or line level, processes them, and delivers them back to you as balanced line, unbalanced line or balanced mic level signals.

### 7.4.1 Stand-alone Operation

A vast majority of users use the 528E as a stand-alone device. Here the 528E replaces their usual microphone preamp and either feeds their tape machine or workstation directly, in essence becoming a one-input, one-output console. Figure 7-2 illustrates the connections needed.

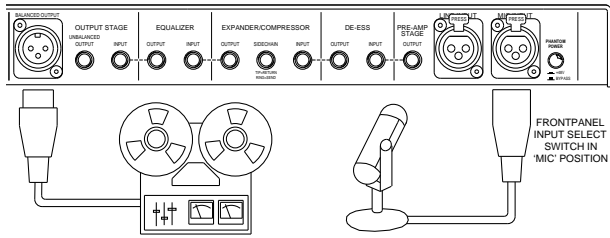

Figure 7-2. Hookup for standalone operation.

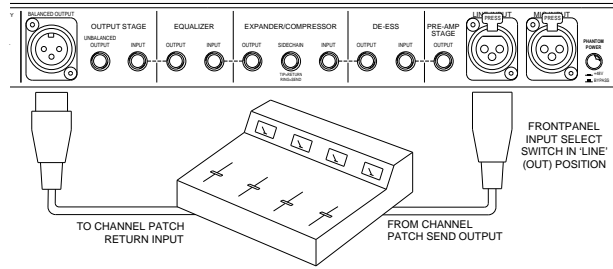

Figure 7-3. Using the 528E as a channel insert device.

For best results, the 528E should replace the mic preamp in your console or recording chain. If you have to plug the 528E into a microphone input (-40 dBu nominal level), then you'll need to pad (attenuate) the output of the 528E down to microphone level. An internal switch reduces the 528E's output to this level. Although a far preferable connection would be to bypass your console's mic preamp, this will work. When configured for mic-level output, the 528E's circuitry doesn't care if phantom powering is or isn't present at the console's mic input. Appendix B contains instructions for altering the output level of the 528E.

**Note:** Padding (attenuating) the output of the 528E back to microphone level is a workable solution towards interfacing the 528E into a console or system having only microphone level inputs. However workable, the ultimate performance of the 528E will be limited by the performance of your system's existing microphone preamps. If you can find a way to bypass the existing microphone preamps in your system, do so. It'll be worth the trouble.

### 7.4.2 Using the 528E as a Channel Insert Device

The 528E can also be used as a channel-insert device with your console. Use the 528E's line input and line output as shown in Figure 7-3.

### 7.4.3 Using the 528E in an Effects Loop

Signal processors used in a console's effects (send-receive) loop should not be insert or series<sup>1</sup> processors. A series processor means that you have to break the signal path to insert the processor. Since using the effects loop does not break the signal path, we don't recommend that you connect the 528E here. Use the channel-insert jacks as described under the previous heading or insert the 528E between your console and your tape machine.

## 7.5 Using the Patch Points

Located on the rear panel are several TRS jacks. These jacks are the connections between the various processors that make up the 528E. The jacks are half-normalled, which means that without any plugs inserted, the signal flows through them via internal switching contacts. The term "half normal" means that only the input or return jack has switching contacts; inserting a plug into the output or send jack does not break the signal path. This allows you to access the signal at various points in the 528E's signal path for use with external processors.

The patch point jacks can be used to insert additional processing into the signal path or perhaps to rearrange the sequence in which the individual processors receive the input signal. Still another possibility would be to use the parametric equalizer in the sidechain of the compressor/downward expander (for additional information on using the sidechain, see the end of this chapter).

<sup>1</sup> An insert or series processor is one that is inserted in *series* with the signal to be modified. Generally speaking, series processors have a wet-dry mix control, however compressors, expanders, gates, equalizers, as well as the **528E**, are all series processors that don't.

## 7.5.1 Inserting Additional Processing

Figure 7-4 shows an external processor inserted between the 528E's equalizer and its output stage. To insert additional (external) processing into the 528E's signal path:

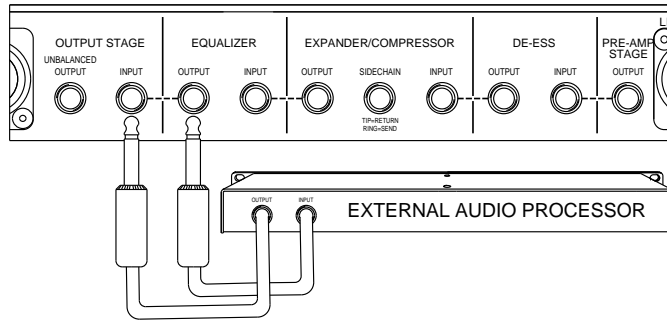

Figure 7-4. Inserting additional processing.

1. Decide where in the signal path you wish to insert the external processor.
2. Patch the appropriate output jack on the 528E to the input jack of the external processor. Use either a TRS or TS patchcord.
3. Patch the output jack of the external processor to the corresponding input jack on the 528E. Use either a TRS or TS patchcord.

## 7.5.2 Changing the Sequence of Processing

You may wish to change the sequence of processing within the 528E to allow the signal processors to work on the input signal in a particular way (your way). A good example of this is the compressor: should the equalizer precede or follow the compressor. Most studio engineers would have the equalizer follow the compressor, like it normally does in the 528E. In broadcast, many engineers prefer the opposite; the compressor receives the output of the equalizer. Figure 7-5 illustrates this patch.

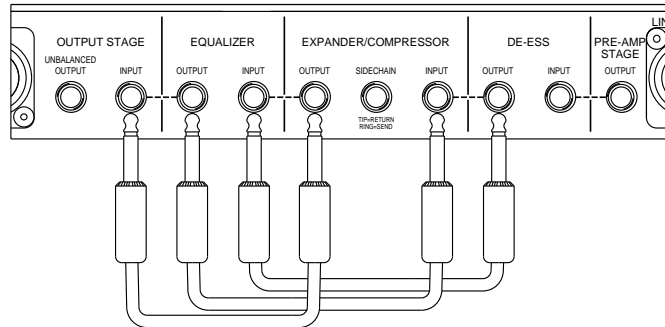

Figure 7-5. Changing the sequence of processing.

## 7.5.3 Using the Equalizer in the Sidechain

For some applications, you may want the 528E's equalizer in its sidechain rather than in the signal path. Doing so makes both the compression *and* downward expansion frequency conscious. Figure 7-6 illustrates this patch. You can find out more about using the sidechain in Chapter 8.

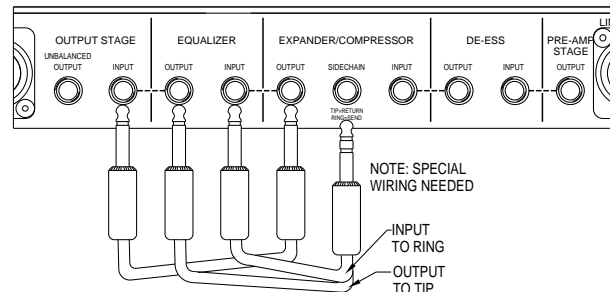

Figure 7-6. Using the equalizer in the dynamics processor's sidechain.



## 7.6 Tips and Techniques for Using the 528E

Following are some tips and techniques for using the 528E. You should consider any settings given as starting points for developing your own settings. More general discussions of these topics may also be found in Chapter 2 of this manual.

### 7.6.1 Metering

The 528E has several LED bargraphs that serve as gain reduction and output meters. The gain-reduction meters indicate the change, from unity gain, for their respective function and the LEDs read (and move) from right to left. When operating as a level meter, the LEDs read (and move) from left to right. Each meter has its own scale markings, as shown on the front panel.

### 7.6.2 Gain Setting

There are two places to adjust the gain of the 528E: at the mic input, before any processing, and at the output. An understanding of this topic is essential to getting the most from your 528E. A more basic discussion can be found under the heading, "Gain Setting," in Chapter 2.

First, the mic input gains. You make best use of the 528Es signal-to-noise ratio by ensuring that your mic-level input signals are adjusted to fit within the headroom of the mic preamp. Doing so ensures optimum dynamic range through the mic preamp and succeeding processors. With the De-esser, Expander/Compressor, and EQ sections temporarily set to BYPASS and the OUTPUT GAIN control set to 0 dB (12:00 o'clock), set the MIC GAIN control so that the OUTPUT LEVEL display indicates levels in the -10 to 0 VU range. The CLIP LED should never illuminate on signal peaks. Remember to restore the settings of the various bypass switches.

Finally, the OUTPUT GAIN. After adjusting all of the other processors, set this control so that the 0 VU LED on the OUTPUT LEVEL meter illuminates. The red CLIP LED should never illuminate.

The output CLIP LED also monitors the EQ section. If the CLIP LED illuminates, reduce the OUTPUT GAIN control setting slightly. You may need to increase the gain of some device following the **528E** to achieve the same overall level.

### 7.6.3 Equalization

The 528Es parametric equalizer has three overlapping bands. Each band can operate as a peaking or dipping equalizer. The boost and cut range for each band is  $\pm 15$  dB. The bandwidth may be varied from 0.3 to 4-octaves wide.

Since the bands overlap, it is possible to apply equalization at the same frequency in two places. Doing so could conceivably increase the signal level by 30 dB at one frequency. You may need to reduce the INPUT or OUTPUT GAIN to avoid distortion. Likewise, large amounts of boost in any one band may require reducing the setting of the OUTPUT GAIN control to prevent overload. Let the OUTPUT CLIP LED be your guide.

Electronic considerations aside, one of the contributing factors to an equalizer's sound is its bandwidth. Table 7-2 lists the bandwidths (octaves) for several (possibly) familiar equalizers, as found on their respective mixing consoles. While we make no promise that the 528E will sound the same, these settings may be a good starting point if one of these equalizers is within your frame of reference.

**Table 7-2. Bandwidth specs, in octaves, for some popular equalizers.**

Name	BW (min)	BW (max)
API 550	1.6	n/a
Focusrite	0.6	1.8
Neve V3	0.2	3.0
SSL G	1.4	2.8
SSL E	0.5	2.5

A parametric equalizer offers perhaps the greatest flexibility of any type of equalizer, however it can be more difficult to arrive at a setting than with other equalizers. A good strategy for setting any equalizer is to set the level control for maximum boost, then vary the Frequency and Bandwidth until you locate the portion of the spectrum that you wish to modify. Then refine the setting of the Level control for that band. Next refine the setting of the Bandwidth control. You may have to go back and forth between Level and Bandwidth to find the magic setting. Toggling the EQ Bypass switch between in and out can help too.

As a rule, it is much easier to hear changes in amplitude (level) than it is to hear bandwidth changes. It is also easier to hear the abundance of something rather than the absence of the same thing. Even if you intend to apply cut (negative level) to a particular frequency, it is still easier to find that frequency by boosting first, tuning second, and resetting the boost/cut last according to taste or need. Finally, you may find that more natural sounds result when you use wider bandwidths for boosting, narrower bandwidths for cutting. Regardless, there are no hard and fast rules and in the end, whatever works for you is best.

It's generally easier to apply boost to a sound for shaping (and that's how many engineers start). Many times, however, you may want to experiment with removing an offending sound (as opposed to drowning it out with something else). In a complex mix, this may work better because it may require less overall EQ to remove the offending sound; the end result will sound more natural.

#### **7.6.4 De-Esser**

The de-esser uses a variable-frequency crossover whose outputs are mixed. The high-frequency path through the mixer is controlled by a VCA whose gain is a function of the sibilance content of the input signal. In sibilant speech, the dominant frequency component is the sibilance itself. Reducing the level of high-frequencies during periods of sibilance reduces the level of the sibilant.

Set the de-esser by adjusting the THRESHOLD level until the de-esser's gain reduction display indicates around -12 dB. Now "tune" the FREQUENCY control until the sibilance is no longer objectionable. Finally, modify the THRESHOLD control setting until you have the desired degree of de-esser action.

#### **7.6.5 Compression**

The compressor generally controls peak levels and helps to maintain a high overall average signal level. Used in this manner, the compressor's action is generally inaudible. Compressors can also be used creatively, to make a source sound louder than it really is, or to create a special effect.

For most level control applications, moderate settings yield the best results. We recommend a starting point of: COMP THRESHOLD control setting sufficient to cause about 6 to 8 dB of gain reduction on peaks using a COMP RATIO setting of 4:1.

For a highly compressed sound (you know, the used car salesman during the 3AM movie), use a 10:1 ratio setting and 10 dB or more of gain reduction.

#### **7.6.6 Downward Expander**

The downward expander reduces its gain for any signal level below its threshold setting. Typically, downward expanders are used to remove noise or unwanted signal from an audio signal by simply lowering the gain when the overall level falls below threshold.

Think about using the expander when you are faced with a noisy signal (not necessarily hiss) or when heavily compressing a voice and you want to remove some of the less desirable artifacts (false teeth rattling, lip smacking, tongue noise, etc.) You can also use the expander to help remove microphone leakage from a signal.

Start by setting the threshold so that the expander causes gain reduction (left LED meter) as the signal falls in level. Increasing threshold levels (less negative numbers) cause further reductions in the overall gain as the signal level falls.

### **7.6.7 Using the Sidechain**

The sidechain is a patch point in the control circuit of a dynamic range processor, which provides access to the part of the circuitry that tells the VCA what to do. The 528E's sidechain routes through a rear panel TRS jack that allows the control signal to be processed outside the unit (see Figure 7-6 for specific hookup information).

Refer to the block diagram at the beginning of this chapter. Notice the sidechain connections that come from the compressor/downward expander section. These connections allow access to the audio signal at the input to the control circuit that drives the dynamics processor. This control signal is derived from, but kept totally separate from, the audio signal path, which means that the control signal can be processed outside the 528E without actually processing the signal that's going through the VCA (the audio signal itself). This presents some very interesting possibilities for changing or improving the operation of the dynamic range processor.

The best use of the sidechain is to make the action of the 528E's compressor/downward expander frequency dependent, that is, to make it respond more (or less) to certain frequencies. Because the audio signal and the control signal remain completely separate (even while the control circuit tells the VCA whether to turn the gain up or down), you can equalize the sidechain without changing the EQ in the main audio path. Removing unwanted frequencies from the control signal before it actually reaches the VCA prevents those frequencies from being used to create gain changes. Applications utilizing the sidechain may be found in the next chapter of this manual.

### **7.6.8 The Voice Symmetry Switch**

Human speech, especially male human speech, contains a great deal of asymmetry. In broadcast (especially AM broadcast), this wastes transmitter power because the asymmetrical waveforms do not utilize the full power of the modulator. The bottom line is that you risk negative overmodulation if you don't correct speech asymmetry before the modulator. The VOICE SYMMETRY switch corrects asymmetric speech waveforms before they get to your board; an added bonus is that you can apply the correction only to the announce mics without affecting the music.

In recording applications, this switch may help give slightly higher overall levels by improving the symmetry of speech signals which may allow lightening up on the compression. Non-speech signals may be adversely affected by the VOICE SYMMETRY switch. Let your ears be your guide.



## 8. Applications

The 528E Voice Processor was designed to make the same kind of specialized processing that's applied to voice-overs and vocal tracks in recording studios available for use in broadcasting, paging, public address and sound reinforcement. In a recording studio, four or five separate pieces of equipment are usually patched together to obtain the kind of processing provided by the 528E.

For the highest level of versatility, we recommend making the output/input patching and sidechain connections available by wiring the unit to a patch bay. Be sure that the interstage patch points are normalled together (we recommend half-normalling) and that the sidechain connection terminates in two half-normalled jacks. This allows access to the individual sections of the 528E, provides for easy use of the sidechain, and allows the processing order to be changed at will (to place the parametric in the sidechain, for instance).

The following discussions illustrate some of the more useful applications for the 528E. Because of its versatility, combinations of the applications described here will normally be used.

### 8.1 Broadcast Applications

With the 528E, a variety of common problems can be corrected, and overall sound quality can be greatly improved. In addition to its "normal" use with announce mics, there are several more specialized uses for the Voice Processor. This section provides general operating guidelines for the various parts of the 528E, and also describes typical applications used in the production room for special effects, in the news room for cleaning up actualities and phone feeds, and in television for PA feed to a studio audience.

The applications that follow are merely operational guidelines for the Voice Processor. The particular kind of processing applied in any given situation must be determined by the problems encountered, and by the dictates of the format. What's necessary or appropriate in one case, may not be at all proper in another.

### 8.2 Announce Mics - Compressing, Limiting, Expanding

The 528E's dynamic range processor is used to control both over-modulation and noise. Noise, in this case, may be electrically induced (hum, buzz, etc.), or acoustically transferred (paper rattling, cart solenoids, air conditioning, etc.), since the downward expander attenuates all below threshold signals without regard to origin. Careful adjustment of the two threshold controls allows the operator to put the 528E to work on any portion of the dynamic range. The expand threshold control governs the 528E's activity in the lower part of the dynamic range, while the comp threshold governs activity in the upper part of the range.

For smooth overall dynamic range processing that will tend to "homogenize" the sound and remove only very low level noises, use a gentle compression ratio with a relatively high comp threshold, and a relatively low expand threshold.

The soft-knee transition characteristic of the interactive processor allows the use of much higher compressor/limiter ratios with much lower thresholds. The expander's rapid rise below its threshold, combined with the compressor's smooth transition through its threshold, makes processing go unnoticed. Use this application to "tighten up" voice-overs. The expander eliminates noise and adds "punch."

The expander may be used without the compressor to remove background noise. Be sure the expand threshold is set low enough to allow even the lowest level speech sounds to pass, and the compression ratio is set to 1 (so the compressor/limiter is essentially out of circuit).

Likewise, the compressor/limiter may be used without the expander to control only the upper end of the dynamic range. For general purpose overall gain control, use compression. Set the

ratio between 2:1 and 3:1, with a comp threshold setting that results in 6dB to 10dB attenuation.

Limiting is used for very definite control of the maximum level. As the name implies, limiting sets the upper limit, but is not intended for general purpose overall gain control. For limiting, set the ratio at 10:1, with the comp threshold control set to provide no more than 3dB to 6dB attenuation.

Bear in mind that limiting is an extreme dynamic control action intended to prevent overload farther down the line. Limiting may be more pleasing to the ear than clipping distortion, but it doesn't sound good enough to be used for more than 6dB attenuation.

### 8.3 Using the De-esser

De-essers are used to reduce the level of certain high frequency vocal sounds like sibilance, over-emphasized fricatives, and lip smacking. The 528E's de-esser provides control over much lower frequencies than would normally be considered "essing." The additional control range greatly enhances the versatility of the de-esser.

### 8.4 Cleaning Up News Feeds

Use the de-esser to reduce unnatural high frequencies, the compressor/limiter to prevent overload, the expander to eliminate noise, and the parametric to make the feed sound better and/or get rid of interference (hiss, noise, extraneous sound, etc.).

Actualities carts<sup>1</sup> that are prepared with the 528E produce an end product with better intelligibility and improved signal to noise ratio. The object of the processing is to keep dynamic range within the real limits of the recording equipment, to eliminate extraneous noise, and to get better sound.

### 8.5 Increasing Gain Before Feedback

To optimize a PA system's response for minimum feedback, tune out the feedback using the parametric equalizer. To find and eliminate resonances that can become feedback problems, turn the system on, with the microphone(s) and speaker(s) in place as they will normally be used, then follow the sequence below. Gain before feedback should increase about 6dB (perhaps as much as 15dB) with this technique.

1. Note the settings of each of the compressor controls.
2. Temporarily set the compressor ratio to 10:1. Increase system gain very carefully until a feedback frequency becomes slightly audible.
3. With the bandwidth set at about .3 octave, and the cut/boost control set for about -15dB, tune the frequency control of one section until the feedback is no longer audible.
4. Increase system gain until feedback becomes slightly audible again.
  - A. If it's the same frequency that was heard first, readjust the same frequency and bandwidth controls until it again subsides.
  - B. If it's a new frequency, repeat Step 2 using another of the EQ sections.
5. Increase gain again to find the third most prominent feedback frequency. Repeat Step 2 using yet another of the EQ sections.
6. Reduce system gain to normal operating levels.

---

<sup>1</sup> An *actualities cart* is a recording (on a Fidelipac cart) of an actual broadcast. An aircheck by any other name. Actualities carts are typically used to give someone else a warm fuzzy feeling.

## 8.6 Parametric EQ in the Sidechain

The parametric equalizer can be placed in the sidechain of the dynamic range processor to make compression, limiting, or expanding action frequency sensitive. The equalizer is patched into the sidechain, so the audio signal that will ultimately become the VCA's control voltage can be equalized before being fed to the detector circuitry (see Chapter 2 for additional information and Chapter 7 for hookup details).

To make the 528E's compressor/limiter more sensitive to high frequencies, boost the high frequencies on the equalizer. This increases the sensitivity of the compressor's control circuits to those particular frequencies, so the compressor/limiter responds more to those frequencies than any others (in effect, the threshold setting is lowered by the extent that the high frequencies have been boosted). Juggling the relationship between the amount of boost and the threshold setting can have the effect of only compressing when the signal contains significant energy in the region boosted by the equalizer. Likewise, cutting or attenuating certain frequencies desensitizes the compressor to those frequencies.

Keep in mind that the COMP THRESHOLD becomes a function of the amount of overall gain through the equalizer, including the boost. This technique can be used with any frequency that can be controlled by the equalizer.

## 8.7 Using Sidechain EQ to Enhance Expander Action

Since the expander can only discriminate between different levels (not different sounds), it can be fooled by signals whose levels are nearly the same, even if the frequency content of those signals is fundamentally different. When the 528E's expander is used to shut out unwanted sounds, any signal that exceeds threshold will trigger the expander. When unwanted signals trigger the system, it's often possible to eliminate the false triggering by equalizing the control signal.

For example, if low frequency signals transmitted through a desk or podium are triggering the 528E's expander unnecessarily:

*With an equalizer in the sidechain, remove the low frequencies from the control signal, and/or boost the higher voice range frequencies.*

When the offending frequencies are removed, and the relative level of the desired frequencies is increased, the expander can tell the difference between the wanted and unwanted signals. Use this technique in any situation where levels are nearly the same, but the fundamental frequencies involved are different.

**NOTE** The ability of the expander to discriminate between wanted and unwanted signals is determined in part by mic technique. Be particularly careful of high frequency sounds entering the side or rear pattern of a cardioid mic. Most cardioids exhibit a sharply rising off-axis response characteristic at higher frequencies. Check the off-axis curve (the lower one) in the manufacturer's literature. If there's only a 3dB to 6dB difference between the on-axis (front) response and the off-axis (side or rear) response in the 5kHz to 10kHz region, high frequency sounds will be picked up by the side or back of your mic.

Use the mic's directional pattern to keep other sources as far off-axis as possible - do everything you can to extract all the source-to-source discrimination possible through good mic technique. The sounds picked up by individual mics must be primarily the sound of the the desired signal, or the expander won't be able to tell the difference.

## 8.8 Using Reverb or Effects

Effects usually require another mixer input for effects return. However, the 528E's patching connections can be used to feed a signal to the effects unit, and the output stage input can be used to return the effects signal to the 528E's output. The only requirement is that the effects

device have a mix control to set the direct/effects signal mix. If you need a hookup diagram, you'll find one in Figure 7-4.

## **8.9 Vocal Processing - Recording and Reinforcement**

The 528E handles a wide variety of program material with ease. When recording vocals, the undesirable side effects that usually result from high ratio comp/limiting, like headphone leakage and room noise, can be reduced with the 528E's interactive expander processing. During mixdown the 528E not only provides compression, but also eliminates the noise that often accompanies vocal tracks that are processed with high frequency EQ, compression, or both.

In sound reinforcement situations, if the threshold has been set correctly, the expander will attenuate whenever a mic is not in use, eliminating extraneous pickup of stage sounds, and reducing feedback from monitor speakers. The operating principle is the same for both the recording and reinforcement situations.

## **8.10 Adding Dynamics, or "Punch"**

By setting the expand threshold above the level of the program material, the 528E can be made to behave like a linear expander (see Chapter 2). With this technique, the 528E can simultaneously create a more dynamic feel, add compression, and reduce noise. Use this kind of processing for special effects, and to increase the dynamic feel of percussive instruments like electric bass, snare drum, rhythm guitar, etc.

Set the expander threshold above the signal level. The compressor/limiter is used to control peaks (and with certain instruments like electric bass, to put in a little more "bottom" by creating extra sustain). Set the comp threshold so the maximum compression is about 6dB with ratios below 2:1, or 3dB with ratios above 2:1.

Since this kind of processing reduces overall output level, use the output gain control to bring levels back up to normal.

## **8.11 High Level Stage Monitors - Dynamic Processing**

Public address and sound reinforcement situations that require compression/limiting are often plagued by feedback problems. Usually the "make up gain" used with compression causes an overall increase in level which in turn, can cause feedback in the absence of signal, when the compressor releases and brings the gain back up to normal.

The 528E's interactive dynamics processor allows the use of large amounts of comp/limiting without serious side effects. When compression is applied to "normal" signal levels, the compressor returns to unity gain when the signal goes away. This action increases overall system gain. The 528E's expander, on the other hand, decreases gain whenever signals fall below threshold. Careful setting of the two threshold controls tells the 528E how and when to adjust the gain.

Stage monitors can be made much "tighter" with compression, but feedback problems often make even gentle, low ratio compression impossible. The 528E's interactive processor performs exceedingly well in this situation, because the expander decreases gain to compensate for the gain increase that results from compression.

Careful adjustment of the expander threshold control will prevent feedback in the absence of signal, even with substantial compression. Note that in most cases the expander threshold must be set higher than the compressor threshold.



## 9. Troubleshooting Chart

Symptom	Probable Cause
No output	<p>Check cables and connections.</p> <p>Are inputs driven by outputs, and outputs driving inputs?</p> <p>Verify cables, source and load by patching input and output connections together, at the unit.</p> <p>Check for AC power presence. POWER LED on?</p> <p>Check output by plugging headphones into output connector (use an adapter).</p> <p>Are the LED displays operating?</p> <p>Is the 528E set for mic-level output?</p> <p>Is the MIC/LINE switch set correctly?</p>
Hum or buzz in output	<p>Check input and output connector wiring (refer to Figure 3.3).</p> <p>Ground loop. Check related system equipment grounding. Are all system components on the <b>same</b> AC ground?</p>
Distortion	<p>Check input signal. Is it too hot, or is it already distorted?</p> <p>Is the OUTPUT display indicating clipping?</p> <p>Is the input clipping?</p> <p>Check output loading. Should be above 600 ohms.</p> <p>Are the power amplifier(s) clipping?</p> <p>Is something else clipping?</p> <p>Is the 528E set for mic-level output, driving a line-level input, with the 528E's gain set fairly high and upstream devices contributing a significant amount of gain?</p>
Noise (hiss)	<p>Check input signal levels, and level control setting.</p> <p>The OUTPUT display should indicate signal, up to but not including the CLIP led.</p> <p>Check gain settings on downstream equipment.</p> <p>The system gain structure should be such that the 528E operates at or near unity gain.</p> <p>Is the input signal already noisy?</p> <p>Is the 528E set for mic-level output, driving a line-level input, with the 528E's gain set fairly high and upstream devices contributing a significant amount of gain?</p>
No LED displays	<p>Is the unit plugged in, and turned on?</p> <p>Is the AC outlet OK?</p>
No nothing	<p>If you are using a condenser microphone, is the phantom power switched on?</p> <p>Do you have the proper input selected?</p> <p>Is everything downstream really live?</p> <p>If you are using the patching jacks, unpatch everything temporarily to see if it is in your patch.</p> <p>Is the downward expander threshold set too high?</p>
Unit not plugged in, but works anyway	<p>Call us.</p>
Need schematic diagram?	<p>Contact the factory.</p>



## 10. Repair and Warranty Information

Should you decide to return your 528E to Symetrix for service, please follow the following instructions.

### 10.1 Return Authorization

Symetrix will service any of its products for a period of five years from the date of manufacture. However, no goods will be accepted without a Return Authorization number.

**BEFORE SENDING ANYTHING TO SYMETRIX, CALL US FOR AN RA NUMBER. JUST ASK, WE'LL GLADLY GIVE YOU ONE! CALL (206) 787-3222 WEEKDAYS, 8AM TO 4:30 PM PACIFIC TIME.**

### 10.2 In-Warranty Repairs

To get your unit repaired under the terms of the warranty:

1. Call us for an RA number.
2. Pack the unit in its original packaging materials.
3. Include your name, address, etc. and a brief statement of the problem. Your daytime telephone number is very useful if we can't duplicate your problem.
4. Put the RA number on the outside of the box.
5. Ship the unit to Symetrix, freight prepaid.

Just do those five things, and repairs made in-warranty will cost you only the one-way freight fee. We'll pay the return freight.

If you choose to send us your product in some sort of flimsy, non-Symetrix packaging, we'll have to charge you for proper shipping materials. If you don't have the factory packaging materials, then do yourself a favor by using an oversize carton, wrap the unit in a plastic bag, and surround it with bubble-wrap. Pack the box full of Styrofoam peanuts. Use additional bubble-wrap if you must ship more than one unit per carton. Be sure there is enough clearance in the carton to protect the rack ears (you wouldn't believe how many units we see here with bent ears). We won't return the unit in anything but original Symetrix packaging. Of course, if the problem turns out to be operator inflicted, you'll have to pay for both parts and labor. In any event, if there are charges for the repair costs, you will pay for return freight. All charges will be COD unless you have made other arrangements (prepaid, Visa or Mastercard).

### 10.3 Out-of-Warranty Repairs

If the warranty period has passed, you'll be billed for all necessary parts, labor, packaging materials, and any applicable freight charges.

Remember, you must call for an RA number before you send the unit to Symetrix.

This Symetrix product is designed and manufactured for use in professional and studio audio systems. Symetrix, Inc. (Symetrix) warrants that this product, manufactured by Symetrix, when properly installed, used, and maintained in accordance with the instructions contained in the product's operator's manual, will perform according to the specifications set forth in the operator's manual.

## 10.4 Symetrix 528E Voice Processor Limited Warranty

Symetrix expressly warrants that the product will be free from defects in material and workmanship for one (1) year. Symetrix' obligations under this warranty will be limited to repairing or replacing, at Symetrix' option, the part or parts of the product which prove defective in material or workmanship within one (1) year from date of purchase, provided that the Buyer gives Symetrix prompt notice of any defect or failure and satisfactory proof thereof. Products may be returned by Buyer only after a Return Authorization number (RA) has been obtained from Symetrix and Buyer will prepay all freight charges to return any products to the Symetrix factory. Symetrix reserves the right to inspect any products which may be the subject of any warranty claim before repair or replacement is carried out. Symetrix may, at its option, require proof of the original date of purchase (dated copy of original retail dealer's invoice). Final determination of warranty coverage lies solely with Symetrix. Products repaired under warranty will be returned freight prepaid via United Parcel Service by Symetrix, to any location within the Continental United States. Outside the Continental United States, products will be returned freight collect.

**The foregoing warranties are in lieu of all other warranties, whether oral, written, express, implied or statutory. Symetrix, expressly disclaims any IMPLIED warranties, including fitness for a particular purpose or merchantability. Symetrix's warranty obligation and buyer's remedies hereunder are SOLELY and exclusively as stated herein.**

This Symetrix product is designed and manufactured for use in professional and studio audio systems and is not intended for other usage. With respect to products purchased by consumers for personal, family, or household use, Symetrix **expressly disclaims all implied warranties, including but not limited to warranties of merchantability and fitness for a particular purpose.**

This limited warranty, with all terms, conditions and disclaimers set forth herein, shall extend to the original purchaser and anyone who purchases the product within the specified warranty period.

Warranty Registration must be completed and mailed to Symetrix within thirty (30) days of the date of purchase.

Symetrix does not authorize any third party, including any dealer or sales representative, to assume any liability or make any additional warranties or representation regarding this product information on behalf of Symetrix.

This limited warranty gives the buyer certain rights. You may have additional rights provided by applicable law.

### 10.4.1 Limitation of Liability

The total liability of Symetrix on any claim, whether in contract, tort (including negligence) or otherwise arising out of, connected with, or resulting from the manufacture, sale, delivery, resale, repair, replacement or use of any product will not exceed the price allocable to the product or any part thereof which gives rise to the claim. In no event will Symetrix be liable for any incidental or consequential damages including but not limited to damage for loss of revenue, cost of capital, claims of customers for service interruptions or failure to supply, and costs and expenses incurred in connection with labor, overhead, transportation, installation or removal of products or substitute facilities or supply houses.

## 11. Specifications

### Inputs

Controls and Switches  
Mic and Line input connectors  
Clip LED

### Microphone input type

Phantom Power (DIN 45 596)  
Gain: pad out  
pad in  
Microphone input maximum input level  
(pad out)  
Input pad  
Equivalent Input Noise (EIN)  
THD (preamp only)  
CMRR

### Line input type and impedance

Line input maximum input level  
Line input nominal input level  
CMRR

### Parametric Equalizer

Type  
Bands

Peak/Dip Bandwidth  
Maximum boost/cut

### Dynamic Range Processor

Type  
Compressor Threshold  
Compression ratio  
Downward Expander Threshold  
Downward Expansion ratio (max)

### De-esser

Type  
Frequency Range  
Threshold  
Rolloff Characteristic

### Output Section

Type  
Maximum output level

Mic level output  
Connector  
Clip LED

Output source impedance  
Minimum load impedance

Voice Symmetry switch

Output gain

Mic Gain, Phantom Power, Mic-Line  
XLR female (2)  
Fires at +17 dBu output level from mic  
preamp or line input preamp  
Wideband, balanced transformerless low  
impedance. Intended for 150-ohm  
microphones.  
+48V, nominal  
variable: 22 to 60 dB  
8 to 45 dB  
-3 dBu  
-15 dB  
-126 dBV. (150 ohm source, 20 Hz - 20 kHz)  
.05% (2 kHz, 50 dB gain, +17 dBu output)  
> 60 dB (55 dB gain, 20-20kHz)  
> 70 dB (55 dB gain, 60 Hz)  
10 kilohm transformerless balanced bridging  
+20 dBu  
+4 dBu  
> 45 dB (0 dBu, 20-20 kHz)

Three-band parametric equalizer  
Low Band 16-500 Hz  
Mid Band 160-6300 Hz  
High Band 680 Hz-22 kHz  
.3 to 4 octaves, measured at maximum boost.  
±15 dB

Interactive compressor/limiter/downward  
expander  
-40 dBu to +20 dBu  
1:1 to 10:1  
Bypass to 0 dBu  
1:1.8

Program controlled high-cut filter  
800 Hz to 8000 Hz  
-30 to 0 dBu  
12 dB/octave, 40 dB/decade

Balanced transformerless  
+18 dBm balanced or unbalanced  
+20 dBu balanced or unbalanced bridging  
-40 dBu (@ 0 VU on the output display)  
XLR male  
Senses multiple internal nodes, fires at 3 dB  
below clipping.  
200 ohms, balanced  
600 ohms balanced or unbalanced. 600-ohm  
termination not required for operation.  
Second-order all-pass filter improves  
modulation symmetry of speech signals.  
±15 dB

## Metering

Type  
Output Level

multi-segment LED bargraph  
-20 to +3 VU (0 VU = +4 dBu), VU calibrated  
peak responding

Gain Reduction

Separate displays for: de-ess, downward  
expander, compressor. 0 to 20 dB per display

## Overall Performance Data

Frequency Response

20 Hz - 20 kHz +0, -0.5 dB, EQ out,  
compressor out, downward expander out, de-  
esser out.

THD  
Noise Floor

.05%, 20-20 kHz, +4 dBm output  
better than -89 dBu, 20 Hz - 22 kHz.

## Physical

Size (hwd), in & cm

1.75 x 19 x 7 in  
4.44 x 48.26 x 17.78 cm

Weight, lbs & kg

7.6 lbs (3.5kg) net  
10 lbs (4.6kg) shipping

## Electrical

Power requirements

117V ac nominal, 105-125V ac 50-60 Hz,  
12.5 watts maximum.  
230V ac nominal, 205-253V ac 50 Hz, 12.5  
watts maximum.

*In the interest of continuous product improvement, Symetrix Inc. reserves the right to alter, change, or modify these specifications without prior notice*

## **Appendix A. Architects and Engineers Specification**

The voice processor shall be capable of all signal processing functions commonly found on a mixing console input channel, including microphone signal preamplification, line input buffering, simultaneous de-essing, downward expansion, and compression/limiting, and parametric equalization.

The unit shall have a low-noise, low distortion microphone preamplifier with variable gain (22dB - 60dB) and switchable (on/off) +48V phantom power. A 15 dB pad shall be provided to accommodate high-output microphone signals. A balanced-bridging line input suitable for +4 dBu input signals shall also be provided along with a switch to select either the microphone or line inputs.

The voice processor shall have an integral de-esser which shall offer up to 20db of attenuation within a manually sweepable frequency range of 800Hz to 8kHz. There shall be front panel controls for range, frequency, and a bypass switch.

The dynamics processing section shall contain an interactive compressor/limiter and downward expander. There shall be front panel controls for compression ratio (1:1 to 10:1), compressor threshold (-50dBm to +20dBm), expander threshold (-30dBm to 0dBm), and a bypass switch.

There shall be a three-band parametric equalizer. Each band shall have  $\pm 15$ dB maximum boost/cut, and continuously variable bandwidth (.3 octaves - 4 octaves). The equalizer bands shall have substantially overlapping frequency ranges, with a combined range of 16Hz to 22kHz. There shall be a front panel bypass switch.

The voice processor shall be equipped with the following LED displays: An eight-segment LED display shall be provided for monitoring the overall output level, six-segment displays for monitoring the de-esser, compressor/limiter, and downward expander. All displays shall be independent. There shall also be a single LED clip indicator to indicate clipping within either of the input preamplifiers or buffers..

The microphone input shall be an active balanced bridging design terminated with 3-pin XLR-female connector (AES/IEC standard wiring). The microphone preamp shall be capable of an equivalent input noise specification of at least -126dBV. The line input shall be a balanced, transformerless design using a 3-pin XLR-female connector (AES/IEC standard wiring). All input circuitry shall incorporate RFI filters of the LC lowpass type.

The output shall be an active balanced design terminated with a 3-pin XLR-male connector (AES/IEC standard wiring). The output signal level shall be switchable to accommodate either line or microphone inputs. The output section shall provide a switchable phase rotator for the purpose of improving the asymmetry of speech waveforms.

Access to the dynamics processing sidechain send/receive shall be provided via a 1/4 inch TRS jack. Access to the interstage connections between all processing sections (mic/line preamp, de-esser, compressor/limiter/downward expander, equalizer, output stage) shall be provided via half-normalled TRS jacks.

The voice processor shall be capable of operating by means of its own built-in power supply connected to 117V nominal AC (105-130V) 50/60 Hz (230V nominal, 207-253V AC, 50 Hz where applicable).

The unit shall be a Symetrix Incorporated model 528E Voice Processor.





## Appendix B.

## Disassembly Instructions and Output Level Switch



**Caution:** These instructions are for use by qualified personnel only. To avoid electric shock do not perform any servicing other than that contained in the operating instructions portion of this manual unless you are qualified to do so. Refer all servicing to qualified service personnel.

**Warning: Lethal voltages are present inside the chassis. Perform all service work with the unit disconnected from all AC power.**

### Tools Required

#2 phillips-head screwdriver.

### Removing the top cover

1. Ensure that the 528E is disconnected from the AC power source.
2. Remove six 6-32 x 1/2 inch screws from each side of the chassis.
3. Remove two 6-32 flat-head screws from the top cover.
4. Lift the top cover free of the chassis.

### Line Output Level

The following procedure changes the output level of the 528E to microphone level (or back to line level). The output switch only affects the signal level at the XLR connector. The unbalanced output is always at line level.

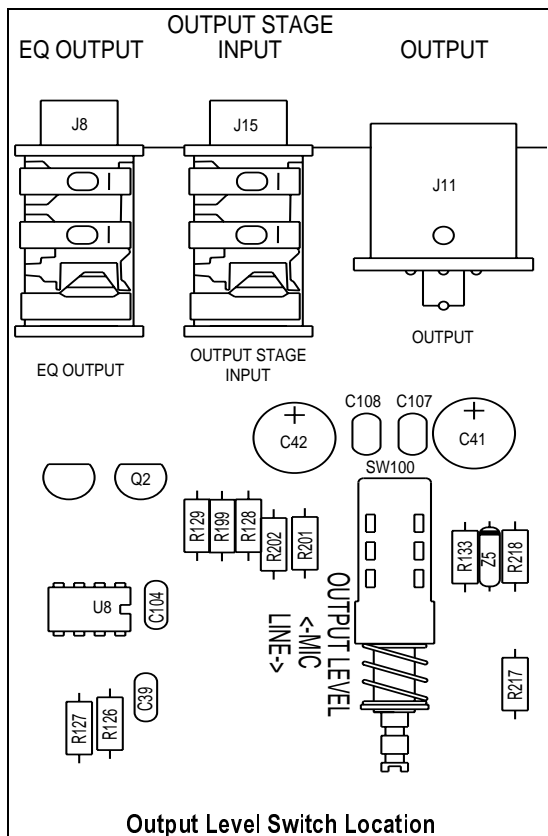

Remove the top cover.

1. Locate the OUTPUT LEVEL switch, located more or less to the rear of the output connector.
2. For microphone level, the switch plunger should be in the IN position (push towards the output connector).
3. For line level output, the switch plunger should be in the OUT position.
5. Reinstall the top cover.



## **Declaration of Conformity**

We, **Symetrix Incorporated**,  
14926 35th Ave. West, Lynnwood, Washington, USA,  
declare under our sole responsibility that the product:

### **528E Voice Processor**

to which this declaration relates,  
is in conformity with the following standards:

#### **EN 60065**

**Safety requirements for mains operated electronic and related apparatus for household and similar general use.**

#### **EN 50081-1**

**Electromagnetic compatibility - Generic emission standard  
Part 1: Residential, commercial, and light industry.**

#### **EN 50082-1**

**Electromagnetic compatibility - Generic immunity standard  
Part 1: Residential, commercial, and light industry.**

The technical construction file is maintained at:

#### **Symetrix, Inc.**

14926 35th Ave. West  
Lynnwood, WA, 98037-2303  
USA

The authorized representative located within the European Community is:

#### **World Marketing Associates**

P.O. Box 100  
St. Austell, Cornwall, PL26 6YU, U.K.

Date of issue: April 1, 1998

Place of issue: Lynnwood, Washington, USA

Authorized signature:



Dane Butcher, President, **Symetrix Incorporated**.

528E

528E

 **Symetrix**



*14926 35th Ave. West  
Lynnwood, WA 98037 USA  
Tel (425) 787-3222  
Fax (425) 787-3211  
Email [symetrix@symetrixaudio.com](mailto:symetrix@symetrixaudio.com)  
Website [www.symetrixaudio.com](http://www.symetrixaudio.com)*