



ENGINEERED SOUND application notes

Restaurant / Retail

MUSIC / PAGE INSTALLATION

- 3 program sources: CD player, tape player, satellite music receiver.
- Program ducking for page-over-music announcements.
- Music-on-hold output for telephone system.
- Remote access to master level control and music source selection.
- Stereo AGC/leveler ensures consistent level of all audio sources.
- Main room output in stereo or mono.

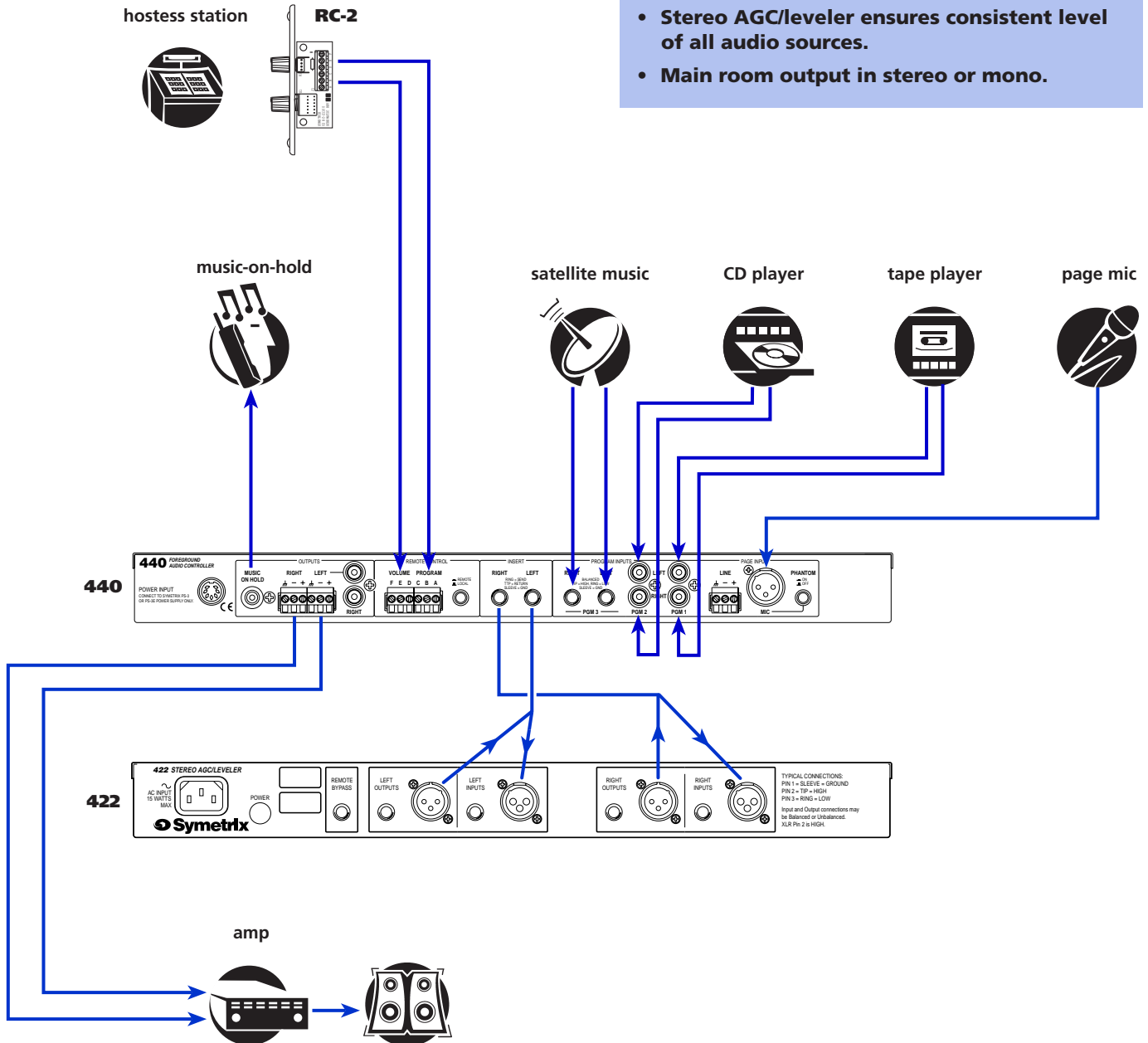

Symetrix Product

Function in Installation

Features

440 Foreground Audio Controller

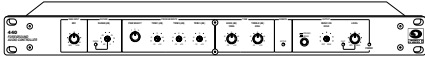

Supplies the page mic preamp, inputs for up to 3 stereo sources, and the necessary ducking for page-over-music announcements. It is the complete music and paging front-end for great sounding systems.

3 switch-selectable stereo program inputs for CD player, satellite music receiver, radio, tape player, or TV audio.

Adjustable page-over-music.

600 ohm transformer-isolated music-on-hold output without the page signal.

Main room output may be in stereo or mono.

Insert jacks to route signals for processing to a device such as the 422 and then back again to the 440.

Internal jumpers for selecting the point at which the page signal is added to the output path. Routing options:

	Pre-Insert	Post-Insert	Post-Tone
1*	program +page	—————>	
2	program	————->	+page —————>
3	program	————->	+page

*default mode

See Appendix B in the 440 user's guide for additional information on routing page and program signals.

422 Stereo AGC/Leveler



Maintains consistent output level regardless of the program source. Smooths system response to varying input levels.

Reduces the variations in playback levels of CDs and tapes.

Keeps the output of the page mic at a consistent level regardless of who is using the mic.

Provides peak limiter for peace of mind protection.

RC-2 Remote Control



Provides remote access to the 440 since equipment is usually out of reach.

Enables remote selection of the program inputs and adjustment of the master volume of the 440.

Adjusts only up to the maximum volume level set on the 440 front panel, which eliminates overdriving the speakers.