

581E Distribution Amplifier



581E

User's Guide

Table of Contents

<i>Chapter 1</i>	Introduction	1
<i>Chapter 2</i>	Operator Safety Summary	2
<i>Chapter 3</i>	Fast Setup	3
<i>Chapter 4</i>	Front Panel Overview	4
<i>Chapter 5</i>	Rear Panel Overview	5
<i>Chapter 6</i>	Connecting to Other Gear	7
<i>Chapter 7</i>	Signal Flow Chart	10
<i>Chapter 8</i>	Troubleshooting	11
<i>Chapter 9</i>	Specifications	12
<i>Chapter 10</i>	Warranty and Service	13
<i>Chapter 11</i>	Declaration of Conformity	15

© April 1999-2001 Symetrix, Inc.

All rights reserved.

Symetrix Part Number 53581E0C00

The information in this guide is subject to change without notice. Symetrix, Inc. shall not be liable for technical or editorial errors or omissions contained herein; nor is it liable for incidental or consequential damages resulting from the furnishing, performance, or use of this material.

Mention of third-party products is for informational purposes only and constitutes neither an endorsement nor a recommendation. Symetrix assumes no responsibility with regard to the performance or use of these products.

Under copyright laws, no part of this user guide may be reproduced or transmitted in any form or by any means, electronic or mechanical, without permission in writing from Symetrix, Inc. If, however, your only means of access is electronic, permission to print one copy is hereby granted.

 **Symetrix**

6408 216th St. SW
Mountlake Terrace, WA 98043 USA
Tel (425) 778-7728
Fax (425) 778-7727
Email: symetrix@symetrixaudio.com



The Symetrix 581E Distribution Amplifier (4x4) is a four-input, sixteen-output distribution amplifier. In a typical configuration the 581E accepts four balanced input signals and distributes each input to four independent outputs. The volume of each of the sixteen outputs may be individually trimmed via its front panel potentiometer. Similarly, the volume of each of the four inputs may be independently controlled. Associated with each input is a four LED level meter to assist the user in setting optimum operating levels. The balanced input stages are designed for high common mode rejection and RF immunity. Output line drivers are stable short-circuit protected and designed around industry standard 5532 type op amps. The 581E operates from an internal power supply built around a low magnetic field toroidal transformer, resulting in a very low noise, high performance product.

The 4x4 architecture of the 581E allows the amplifier to fit the greatest possible number of configurations. Each one input, four output module is independent of the others. Wiring the 581E's inputs to four separate audio sources provides four mono distribution channels with four outputs each. This

configuration also accommodates two stereo audio feeds.

Stereo audio can be distributed to eight inputs by strapping the 581E's inputs together in pairs. Left channel audio is wired to inputs #1 and #2, while the right channel connects to inputs #3 and #4.

The 581E distributes a single mono audio source to all 16 outputs when all inputs are strapped together. Regardless of your audio distribution requirements, the Symetrix 581E solves the problem with minimum cost and no wasted outputs.

Feel free to contact us if you have questions, comments, or suggestions.

Phone (425)778-7728

Fax (425)778-7727

Email symetrix@symetrixaudio.com

Website www.symetrixaudio.com

Our office hours are 8:00am (800 hours) to 4:30pm Pacific Time.

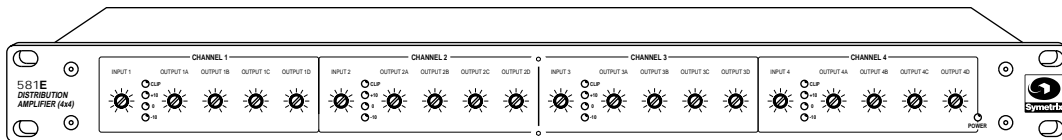

Front panel

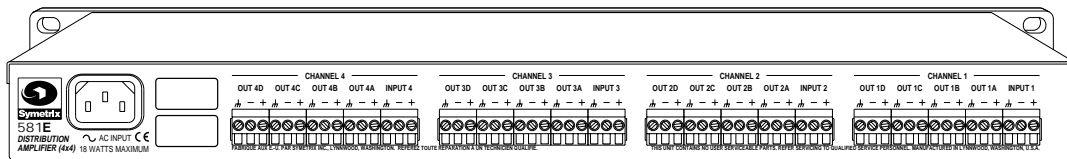

Rear panel

581E

Equipment Markings

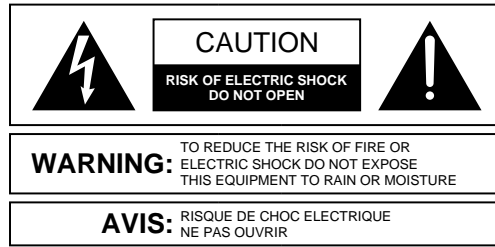

SEE OWNERS MANUAL. VOIR CAHIER D'INSTRUCTIONS.
No user serviceable parts inside. Refer servicing to qualified service personnel.
Il ne se trouve à l'intérieur aucune pièce pouvant être réparée l'utilisateur.
S'adresser à un réparateur compétent.

The lightning flash with arrowhead symbol within an equilateral triangle is intended to alert the user of the presence of uninsulated "dangerous voltage" within the product's enclosure that may be of sufficient magnitude to constitute a risk of electric shock to persons. The exclamation point within an equilateral triangle is intended to alert the user of the presence of important operating and maintenance (servicing) instructions in the literature accompanying the product (i.e. this manual).

Caution *To prevent electric shock, do not use the polarized plug supplied with the unit with any extension cord, receptacle, or other outlet unless the blades can be fully inserted.*

Terms

Several notational conventions are used in this manual. Some paragraphs may use **Note**, **Caution**, or **Warning** as a heading. Certain typefaces and capitalization are used to identify certain words. These are:

Note	Identifies information that needs extra emphasis. A Note generally supplies extra information to help you to better use the 581E.
Caution	Identifies information that, if not heeded, may cause damage to the 581E or other equipment in your system.
Warning	Identifies information that, if ignored, may be hazardous to your health or that of others.
CAPITALS	Controls, switches or other markings on the 581E's chassis.
Boldface	Strong emphasis.

Important Safety Instructions

Please read and keep these instructions. Heed and follow all warnings and instructions. Install in accordance with the manufacturer's instructions.

Power Source This product is intended to operate from a power source that does not apply more than 250V rms between the power supply

conductors or between either power supply conductor and ground. A protective ground connection, by way of the grounding conductor in the power cord, is essential for safe operation.

Grounding The chassis of this product is grounded through the grounding conductor of the power cord. To avoid electric shock, plug the power cord into a properly wired receptacle before making any connections to the product. A protective ground connection, by way of the grounding conductor in the power cord, is essential for safe operation. **Do not defeat the safety purpose of the grounding plug.** The grounding plug has two blades and a third grounding prong. The third prong is provided for your safety. When the provided plug does not fit your outlet, consult an electrician for replacement of the obsolete outlet.

Danger from Loss of Ground If the protective ground connection is lost, all accessible conductive parts, including knobs and controls that may appear to be insulated, can render an electric shock.

Proper Power Cord Use only the power cord and connector specified for the product and your operating locale. Use only a cord that is in good condition. **Protect the power cord** from being walked on or pinched, particularly at plugs, convenience receptacles, and the point where they exit from the apparatus.

Operating Location **Do not operate this equipment under any of the following conditions:** explosive atmospheres, in wet locations, in inclement weather, improper or unknown AC mains voltage, or if improperly fused. Do not install near any heat source such as radiators, heat registers, stoves, or other apparatus (including amplifiers) that produce heat. Unplug this apparatus during lightning storms or when unused for long periods of time.

Stay Out of the Box To avoid personal injury (or worse), do not remove the product covers or panels. Do not operate the product without the covers and panels properly installed. Only use accessories specified by the manufacturer. Clean only with a damp cloth.

User-serviceable parts There are no user serviceable parts inside the 581E. In case of failure, refer all servicing to the factory. Servicing is required when the 581E has been damaged in any way, such as when a power supply cord or plug is damaged, liquid has been spilled or objects have fallen into the apparatus, the apparatus has been exposed to rain or moisture, does not operate normally, or has been dropped.

581E

Fast First-Time Setup

Follow these instructions to get your 581E up-and-running as quickly as possible. The intent of this section is fast setup. Refer to later chapters for explanation of the 581E's controls and functions.

- ❶ Connect audio inputs and outputs. If you do not know how to do this, forget Fast Set-Up and read Chapter 5.
- ❷ Set INPUT level trim controls straight up (12 o'clock position).
- ❸ Set OUT level trim controls at maximum level (clock-wise rotation).
- ❹ Plug the 581E into an AC outlet using the IEC-type detachable power cord provided with the unit.

Caution: *Failure to connect the 581E to the proper AC mains voltage may cause fire and/or internal damage.*

Warning: **Lethal voltages are present inside the chassis. There are no user serviceable parts inside the chassis. Refer all service to qualified service personnel or to the factory.**

- ❺ Apply line level audio signal to the input(s). "Line level" means previously amplified audio, i.e. not the output of a microphone or other unamplified audio transducer.
- ❻ Turn up the INPUT level pot(s) until the red CLIP LED just barely lights. Then back the level down just a bit until the CLIP LED doesn't come on any more, or only occasionally flashes.
- ❼ Now read the rest of this user's guide.

581E

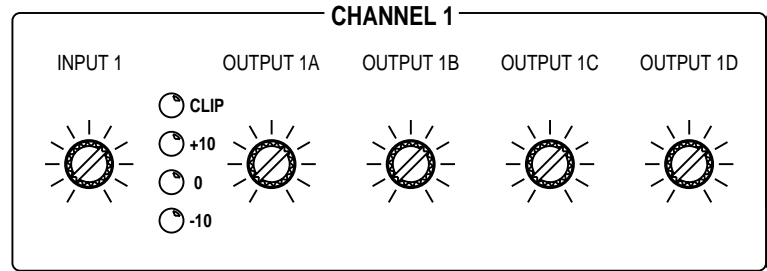

Front panel drawing

Input Level Controls

The four input level controls on the 581E are marked INPUT 1, INPUT 2, INPUT 3 and INPUT 4. Each control adjusts its corresponding input signal over a 30dB range. With signal applied to input(s) turn up the INPUT level pot(s) until the red CLIP LED just barely lights. Then back the level down just a bit until the CLIP LED doesn't come on any more, or only occasionally flashes. This is the optimum setting and will provide the greatest signal-to-noise ratio without distortion.

If your incoming signal positions are unpredictable then we suggest a straight up (12 o'clock) setting. Since the 581E's input has 18dB of headroom above +4dBu, this setting should work well under most conditions.

If you find that your input signal is very low (the output of a "-10" consumer level device, such as a CD player, for example), turn the INPUT level control clockwise to boost the signal. Conversely, if you're feeding a "+8" broadcast level signal to the 581E then turn the INPUT level control counterclockwise until the proper LED display is achieved.

Output Level Controls

The sixteen output level controls on the 581E are marked OUT 1A, OUT 1B, OUT 1C, OUT 1D, OUT 2A, OUT 2B, etc. Use these controls to attenuate the output level over a 20dB range. Start by turning all controls fully clockwise (unity gain). This will create equal levels from all outputs. If for some reason you wish to reduce the level of certain outputs then turn the appropriate control(s) counterclockwise. Otherwise, for better overall system performance it's best to leave the controls wide open (full clockwise) for the hottest possible output signals.

581E

The 581E is fitted with removable terminal blocks for both input and output connections. While not absolutely necessary, it is usually much easier to unplug the removable block before making or changing connections.

INPUTS

The four 581E inputs are balanced. Of course, they may be used in unbalanced configurations but for optimum system wide performance (best noise rejection) balanced operation is highly recommended, whenever possible. Be sure and use shielded cable for both input and output connections. The wire should always be two-conductor plus shield, even for unbalanced connections.

For balanced input signals:

1. Connect the incoming signal “+” (high) to the “+” INPUT terminal of the 581E.
2. Connect the incoming signal “-” (low) to the “-” INPUT terminal of the 581E.
3. Connect the incoming signal ground (shield) to the ground terminal of the 581E. Repeat for all inputs.

For unbalanced input signals, using two-conductor shielded cables:

1. Connect the incoming signal “+” (high) to the “+” INPUT terminal of the 581E. Use the red wire.
2. Connect the incoming signal ground to the “-” INPUT terminal of the 581E. Use the black wire.
3. Connect the cable shield at the ground connection of the 581E only.

If you experience hum or noise, make sure that both the 581E and the device which you are feeding are grounded on the same AC mains circuit. If this is not the source of the noise problem, you must isolate the unbalanced output from the balanced input with an audio transformer or “matchbox.”

WIRING THE 581E IN 2x8 or 1x16 CONFIGURATION

To connect the 581E as a 2 input, 8 output distribution amplifier proceed as follows:

1. Connect the two incoming signals to INPUT 1 and INPUT 2 as per the instructions above.
2. Connect (4) additional short pieces of #20 or #22 gauge wire as follows:

INPUT 1 “+” to INPUT 3 “+”

INPUT 1 “-” to INPUT 3 “-”

INPUT 2 “+” to INPUT 4 “+”

INPUT 2 “-” to INPUT 4 “-”.

To connect the 581E as a 1 input, 16 output distribution amplifier proceed as follows:

1. Connect the single incoming signal to INPUT 1 as per the instructions above.
2. Connect (6) additional short pieces of #20 or #22 gauge wire as follows:

INPUT 1 “+” to INPUT 2 “+”

INPUT 2 “+” to INPUT 3 “+”

INPUT 3 “+” to INPUT 4 “+”

INPUT 1 “-” to INPUT 2 “-”

INPUT 2 “-” to INPUT 3 “-”

INPUT 3 “-” to INPUT 4 “-”



OUTPUTS

The 581E's four outputs are active balanced circuits and should be used to feed balanced audio inputs. Use two-conductor shielded audio cable for all connections.

Feeding balanced inputs:

1. Connect the "+" (high) OUTPUT terminal of the 581E to the "+" (high) of the input of the device which you are feeding.
2. Connect the "-" (low) OUTPUT terminal of the 581E to the "-" (low) of the input of the device which you are feeding.
3. Connect cable shield to the ground of the 581E and the ground connection of the device which you are feeding.

Feeding unbalanced inputs:

WE DON'T RECOMMEND IT. If you must feed an unbalanced input with the 581E, you should isolate the two devices with either an audio transformer or an interface matching device (a "matchbox"). The 581E follows the AES standards for balanced audio circuits. The ground connections of the amplifier are chassis ground.

If you must connect the output of the 581E directly to an unbalanced input, try this procedure. Use two-conductor shielded audio cable.

1. Connect the "+" (high) OUTPUT terminal of the 581E to the "+" (high) of the unbalanced input.
2. Make no connection to the "-" (low) OUTPUT terminal of the 581E.
3. Connect the cable shield at the 581E's ground and at the input connector of the unbalanced input.

The output signal level of the 581E will be 6 dB lower when driving an unbalanced input without a transformer or matching interface device.

If you experience hum or noise, make sure that both the 581E and the device which you are feeding are grounded on the same AC mains circuit. If this is not the source of the noise problem, you must isolate the balanced output from the unbalanced input with an audio transformer or "matchbox."

Matching Levels vs Matching Impedances

In any audio equipment application, the question of “matching” inevitably comes up. Without digging a hole any deeper than absolutely necessary, we offer the following discussion to (hopefully) clarify your understanding of the subject.

Over the years, we have all had impedance matching pounded into our heads. This is important only for vintage audio systems, power amplifiers, and RF. Technically speaking, the reason is power transfer, which reaches a maximum when source and load are matched. Modern audio systems are voltage transmission systems and source and load matching is not only unnecessary, but undesirable as well.

- ❑ Vintage audio systems operate at 600 ohms (or some other impedance value), and must be matched, both at their inputs and at their outputs. Generally speaking, if you are dealing with equipment that uses vacuum tubes, or was designed prior to 1970, you should be concerned about matching. These units were designed when audio systems were based on maximum power transfer, hence the need for input/output matching.
- ❑ Power amplifiers are fussy because an abnormally low load impedance generally means a visit to the amp hospital. Thus, it's important to know what the total impedance of the pile of speakers connected to the amplifier really is.
- ❑ RF systems are matched because we really are concerned with maximum power transfer and with matching the impedance of the transmission line (keeps nasty things from happening). Video signals (composite, baseband, or otherwise) should be treated like RF.

Some folks seem to believe that balanced/unbalanced lines and impedances are related; or even worse that they are associated with a particular type of connector. **Not so.** Unbalanced signals are not necessarily high-impedance and balanced signals/lines are not necessarily low-impedance. Similarly, although 1/4 inch jacks are typically used for things like guitars (which are high-impedance and unbalanced), this does not predispose them to only this usage. After all, 1/4 inch jacks are sometimes used for loudspeakers, which are anything but high-impedance. Therefore, the presence of 3-pin XLR connectors should not be construed to mean that the input or output is low-impedance (or high-impedance). The same applies to 1/4 inch jacks.

So, what is really important? Signal level, and (to a much lesser degree), the impedance relation between an output (signal source) and the input that it connects to (signal receiver).

Signal level is very important. Mismatch causes either loss of headroom or loss of signal-to-noise ratio. Thus, microphone inputs should only see signals originating from a microphone, a direct (DI) box, or an output designated microphone-level output. Electrically, this is in the range of approximately -70 to -20 dBm. Line inputs should only see signals in the -10 to +24 dBm/dBu range. Guitars, high-impedance microphones, and many electronic keyboards do not qualify as line-level sources.

The impedance relation between outputs and inputs needs to be considered, but only in the following way - *Always make sure that a device's input impedance is higher than the output source impedance of the device that drives it.*

Some manufacturers state a relatively high-impedance figure as the output impedance of their equipment. What they really mean is that this is the minimum load impedance that they would like their gear to see. In most cases, seeing a output impedance figure of 10,000 (10K) ohms or higher from modern equipment that requires power (batteries or AC) is an instance of this type of rating. If so, then the input impedance of the succeeding input must be equal to or greater than the output impedance of the driving device.

Symetrix equipment inputs are designed to bridge the output of whatever device drives the input (i.e. to be greater than 10 times the actual source impedance). Symetrix equipment outputs are designed to drive 600-ohm or higher loads (600-ohm loads are an archaic practice that won't go away). You don't need to terminate the output with a 600-ohm resistor if you aren't driving a 600-ohm load. (If you don't understand the concept of termination, you probably don't need to anyway.)



The two facts that you need to derive from this discussion are:

- Match signal levels for best headroom and signal-to-noise ratio.
- For audio, impedance matching is only needed for vintage equipment and power amplifier outputs. In all other cases, ensure that your inputs bridge your outputs (meaning the inputs are in the range of 2 to 200 times the output source impedance).

Signal Levels

The 581E is designed around studio/professional line levels: +4 dBu or 1.23 volts RMS. The unit is quiet enough to operate at lower signal levels such as those found in semi-pro or musical instrument (MI) equipment (-10 dBu or 300 millivolts).

I/O Impedances

The 581E is designed to interface into almost any recording studio or sound reinforcement application. This includes:

- 600-ohm systems where input and output impedances are matched.
- Modern bridging systems where inputs bridge and outputs are low source impedances (voltage transmission systems).

The 581E's input impedance is greater than 20-kilohms balanced. The inputs may be driven from any balanced source capable of delivering at least -10 dBu into the aforementioned impedances.

The 581E's output impedance is 600 ohms balanced, 300 ohms unbalanced. The output line driver delivers +22 dBm into 600-ohm balanced loads or +18 dBm into 600-ohm unbalanced loads.

Input and Output Connections

The illustration on the next page shows how to connect the 581E to balanced and unbalanced sources and loads.

To operate the 581E from unbalanced sources, run a 2-conductor shielded cable (that's two conductors plus the shield) from the source to the 581E. At the source, connect the low/minus side to the shield, these connect to the source's ground; connect the high/plus side to the source's signal connection. At the 581E, the high/plus wire connects to pin 2, the low/minus wire connects to pin 3, and the shield (always) connects to pin 1. This is the preferred method as it makes best use of the 581E's balanced input (even though the source is unbalanced). The other alternative shown in the illustration converts the 581E's balanced input into an unbalanced input at the input connector. This works, but is more susceptible to hum and buzz than the preferred method. There is no level difference between either method.

You can drive unbalanced loads with the 581E's outputs by using the XLR connector with pin 3 left open. In an emergency (the show must go on), you can ground pin 3, but if you have the choice...leave it open. If you must ground pin 3, it must be grounded at the 581E, rather than at the other end of the cable. The price, regardless of whether or not pin 3 is grounded is 6 dB less output level. If your system is wired with pin 3 hot, and you are driving an unbalanced load, **pin 2 must float**.

581E

Balanced Terminal Strip

(When Using CIRCUIT Ground)
(Wire Shield Not Connected)

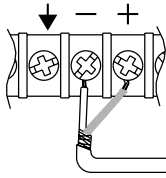

Two Conductor
Shielded Cable

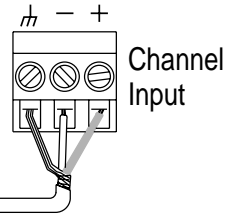

Balanced Female XLR

(When Using CIRCUIT Ground)

Pin 1=Not Connected

Pin 2 = High

Pin 3 = Low

Shield Tab = Not Connected

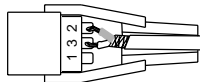

Two Conductor
Shielded Cable

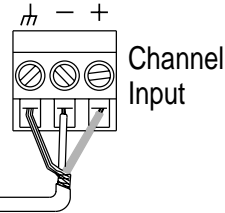

TRS Plug

(When Using CIRCUIT Ground)

Tip = High

Ring = Low

Sleeve = Not Connected

(Wire Shield Not Connected)

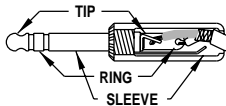

Two Conductor
Shielded Cable

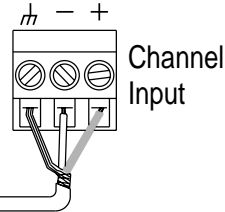

TS Plug

(When Using CIRCUIT Ground)

Tip = High

Sleeve = Low

(Wire Shield Not Connected)

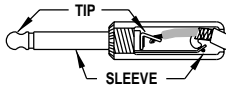

Two Conductor
Shielded Cable

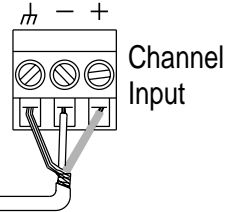

RCA Plug

(When Using CIRCUIT Ground)

Tip = High

Sleeve = Low

(Wire Shield Not Connected)

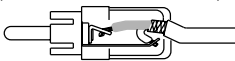

Two Conductor
Shielded Cable

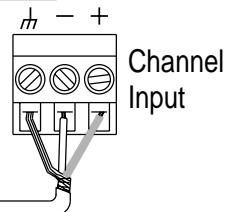

Balanced Male XLR

(When Using CIRCUIT Ground)

Pin 1= Circuit Ground

Pin 2 = High

Pin 3 = Low

Shield Tab = Not Connected

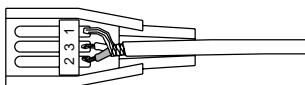

Two Conductor
Shielded Cable

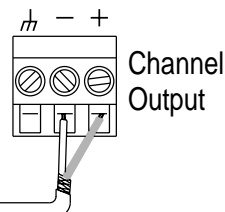

TS Plug

(When Using CIRCUIT Ground)

Tip = High

Sleeve = Shield

(Wire Low Not Connected)

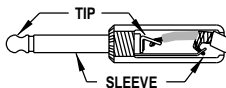

Two Conductor
Shielded Cable

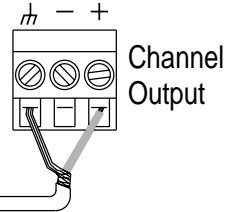

WLS

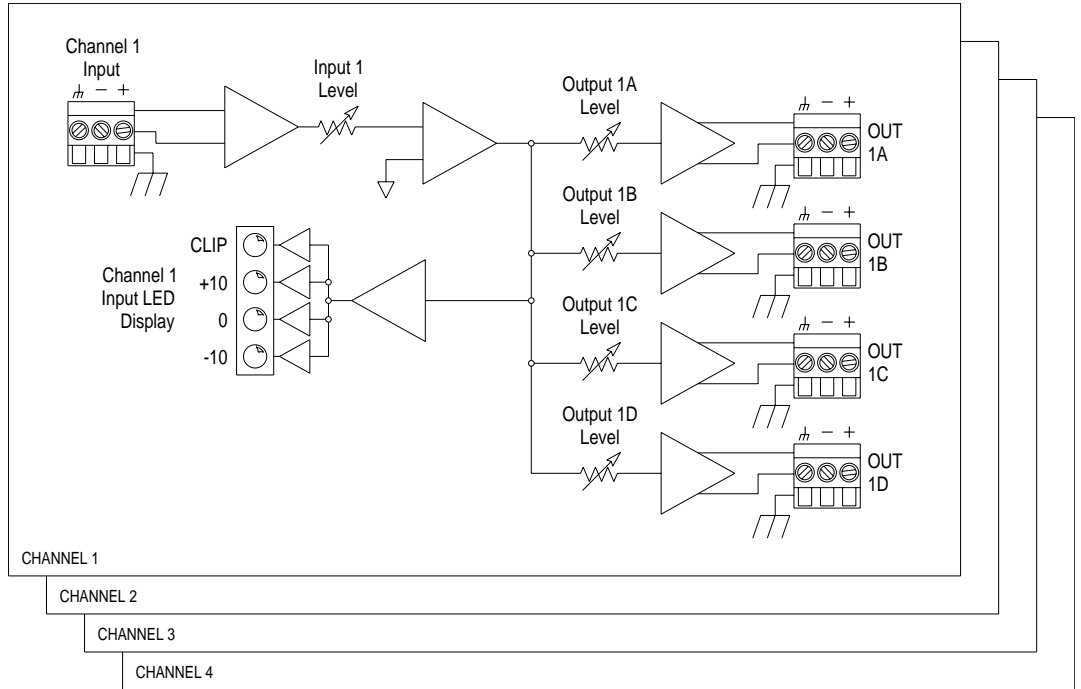

581E

Troubleshooting Chart

<u>SYMPTOM</u>	<u>PROBABLE CAUSE</u>
No output signal	Check cables and connections. Are inputs driven by outputs, and outputs driving inputs? Verify cables, source and load by patching input and output connections together, at the unit. Check for AC power presence.
Hum or buzz in output	Check input and output connector wiring (refer to page 9). Ground loop: check related system equipment grounding. Are all system components on the same AC ground?
Distortion	Check the level of the input signal on the 581E's LED display(s). Is the CLIP light on all the time? If so, reduce the incoming signal level by turning the INPUT level counterclockwise. Is the incoming signal already distorted? Listen "up stream" from the 581E to make sure you're feeding it a clean signal.
Noise (hiss)	Check input signal levels and input level control settings. The input signal may be too low. If so, boost the incoming signal (if possible). Is the input signal already noisy? Listen "up stream" from the 581E to determine that you are feeding it a clean signal.
No LED display	Is the unit plugged in, and turned on? Is the AC outlet OK?

581E

Architects and Engineers Specifications

The audio distribution amplifier shall be a four channel unit with each channel consisting of one electronically balanced input amplifier and four electronically balanced output amplifiers. Associated with each channel shall be a master gain adjustment circuit capable of up to 15dB of gain or 15dB of loss for the purpose of optimally matching incoming signal level(s). Also associated with each channel shall be a four LED array for the indication of the signal levels applied to the output drive circuits. The LED's shall be labelled CLIP, +10, 0, and -10 corresponding to internal signal levels of +18dBu, +10dBu, 0dBu, and -10dBu.

Each output shall be capable of driving a 600-ohm balanced load to a level of +22 dBm. The maximum output level into a balanced bridging load (20K Ohms) shall be +26 dBu. Each output will offer an individual attenuator with a range of 0 to -20 dB.

Frequency response through the amplifier shall be $\pm\frac{1}{2}$ dB, measured between 20 Hz and 20 kHz. THD+Noise shall be less than 0.009% measured at unity gain with a bandwidth of 30 kHz. Residual noise will be >100 dB below a +4 dBu input signal when measured with an A-weighting filter.

The unit shall occupy one rack space (1U). The physical dimensions shall be 1.72"H x 19"W x 6"D; 4.45cm H x 43.7cm W x 15.24cm D.

The distribution amplifier shall operate by means of its built-in power supply connected to 117V AC, nominal, 95-130V AC, 50-60 Hz; or 230V AC nominal, 165-255V AC, 50 Hz. Power consumption shall be 18 watts, maximum. There shall be a rear panel receptacle for an IEC type detachable power cord. The distribution amplifier shall carry the CE mark.

The distribution amplifier shall be a Symetrix, Inc. model 581E Distribution Amplifier (4x4).



Specifications

Input/Output	
Maximum Input Level	+26 dBu Balanced
Maximum Output Level	+26 dBu Balanced (20k Ohm load) +22 dBm (600 Ohm load)
Input Impedance	20k Ohms Balanced, 10k Ohms Unbalanced
Output Impedance	200 Ohms Balanced, 100 Ohms Unbalanced
Performance Data	
Frequency Response	$\pm\frac{1}{2}$ dB, 20 Hz - 20 kHz
THD+Noise	<.009%, unity gain input to output, 30kHz measurement bandwidth
Signal to Noise Ratio	>100dB, A-weighted, ref. to +4dBu
Dynamic Range	>125 dB, A-weighted
Common Mode Rejection	>40 dB, 20 Hz - 20 kHz
Input Gain Range	\pm 15dB
Output Gain Range	0 to -20dB

Physical	
Size (hwd)	1.72 x 19 x 6 in., 4.37 x 48.26 x 15.24 cm.
Shipping Weight	8 lbs

Electrical	
Power Requirements	117V AC nominal, 95-130V AC, 50-60 Hz 230V AC nominal, 165-255V AC, 50Hz
Power Consumption	18 watts maximum

Note: The maximum operating ambient temperature is 25 degrees C.

In the interest of continuous product improvement, Symetrix, Inc. reserves the right to alter, change, or modify these specifications without prior notice.
© 1999, Symetrix, Inc. All rights reserved.

Warranty

Symetrix, Inc. expressly warrants to the original purchaser (“Buyer”), subject to the terms and conditions set forth below, that the Product will be free from defects in material and workmanship as a result of normal commercial use for (18) months from the date of shipment.

Symetrix’s warranty obligation is limited to the repair, replacement, or refund at Symetrix’s sole discretion, of the part or parts of the Product which may thus prove defective in materials or workmanship within (18) months from date of shipment under normal use and which our examination discloses to our satisfaction to be thus defective, provided that Buyer gives Symetrix prompt notice of its warranty claim and satisfactory proof thereof.

Symetrix will make every reasonable effort to ensure that parts are available to support the repair of our products under warranty. In the event that a product or component part thereof becomes obsolete, unavailable or irreparable, Symetrix reserves the right to refund a prorated portion of the purchase price in full satisfaction of all warranty claims. A refund of the purchase price is prorated as follows: 100% through year one, 80% through year two, 60% through year three, 40% through year four and 20% through year five.

In order to serve you better we request that the Buyer shall, prior to shipping Product to Symetrix for warranty service, contact Symetrix and secure a Return Authorization Number that shall be included with the returned Product. This will facilitate our efforts to keep track of your Product and process your warranty repair as quickly as possible. Buyer will prepay all freight charges to ship the Product to Symetrix for warranty inspection and service. This warranty is subject to Symetrix’s inspection of the Product at its facilities and, upon Symetrix’s request, satisfactory proof of purchase (dated copy of original retail dealer’s invoice.)

Symetrix reserves the right to effect repairs to the product with reconditioned components/parts. Products once repaired under warranty will be shipped to Buyer freight prepaid by Symetrix via United Parcel Service (surface) or any similar shipper, to any location designated by buyer within the Continental United States. At Buyer’s request and expense Product will be returned via airfreight. Outside the continental United States, repaired or replaced products will be returned freight collect.

THIS WARRANTY IS EXPRESSLY IN LIEU OF ALL OTHER WARRANTIES EXPRESS OR IMPLIED, ARISING BY LAW OR OTHERWISE (INCLUDING, WITHOUT LIMITATION ANY OBLIGATIONS OF THE SELLER WITH RESPECT TO CONSEQUENTIAL DAMAGES) INCLUDING THE WARRANTIES OF MERCHANTABILITY AND FITNESS FOR USE AND OF ALL OTHER OBLIGATIONS OR LIABILITIES ON OUR PART, AND WE NEITHER ASSUME, NOR AUTHORIZE ANY OTHER PERSON TO ASSUME FOR US, ANY OTHER LIABILITY IN CONNECTION WITH THE SALE OF THE PRODUCT. THIS WARRANTY SHALL NOT APPLY TO THIS PRODUCT OR ANY PART THERE OF WHICH HAS BEEN SUBJECT TO ACCIDENT, NEGLIGENCE, ALTERATION, ABUSE, OR MISUSE. WE MAKE NO WARRANTY WHATSOEVER IN RESPECT TO ACCESSORIES OR PARTS NOT SUPPLIED BY US. THE TERM “ORIGINAL PURCHASER,” AS USED IN THIS WARRANTY SHALL BE DEEMED TO MEAN THAT PERSON OR COMPANY THAT ORIGINALLY PURCHASED THE PRODUCT.

This Symetrix product has been designed and manufactured for use in professional/industrial systems and is not intended for other usage. This warranty only applies to Buyers using the Product professional/industrial systems. With respect to others, including but not limited to consumers for personal, family, or household use, Symetrix expressly disclaims all warranties, including but not limited to warranties of merchantability and fitness for a particular purpose and the express warranties as otherwise provided herein.

Symetrix reserves the right to modify the design or make additions to, or improvements to, its product lines without making similar upgrades to Product purchased by Buyer. Symetrix does not authorize any third party, including any dealer or sales representa-

WE
18
5

tive, to assume any liability, effect any repairs or modifications to the Product, or make any additional warranties or representation regarding the Product or Product information on behalf of Symetrix.

Symetrix's total liability on any claim, whether in contract, tort (including negligence) or otherwise arising out of, connected with, or resulting from the manufacture, sale, delivery, resale, repair, replacement or use of Product will not exceed the purchase price of the Product or any part thereof which gives rise to the claim. In no event will Symetrix be liable for any incidental or consequential damages including but not limited to damage for lost revenue, cost of capital, claims of customers for service interruptions or failure to supply, and costs and expenses incurred in connection with labor, overhead, transportation, installation or removal of products or substitute facilities or supply houses as a result of Product failure.

This limited warranty gives Buyer certain rights. Buyer may have additional rights under applicable law.

Where to Get Service

If outside of the USA
If you have determined that your 581E requires repair services and you live outside of the United States, please contact your local Symetrix dealer or distributor for instructions on how to obtain service.

If inside the USA

Symetrix will perform in-warranty or out-of-warranty service on any product it has manufactured for a three years from date of discontinued manufacture. If you reside in the USA, then proceed as follows:

In-Warranty Repairs

Repairs made in-warranty will cost you only one-way freight charges. We'll prepay the return (surface) freight. Of course, if the repair is due to operator error, parts and labor will be charged. If there are charges for the repair costs, you will pay for the return freight. All charges will be COD unless you have made other arrangements (prepaid, Visa, or Mastercard).

Out-of-Warranty Repairs

If the warranty period has passed, you'll be billed for all necessary parts, labor, packaging materials, and freight charges.

To Get Your 581E Unit Repaired (USA Customers Only)

- 1 Call our Technical Services Group for a return authorization (RA) number.
(425) 778-7728,
Monday through Friday,
8:00 am to 4:30 pm Pacific Time.
Have your serial number ready to give to the service representative.
- 2 Pack the unit in its original packaging materials.
Include your name, address, daytime telephone number, and a brief statement of the problem.
- 3 Write the RA number on the outside of the box.
- 4 Ship the unit to Symetrix, freight prepaid. We do not accept freight collect shipments.

Symetrix, Inc.
6408 216th St. SW
Mountlake Terrace, WA 98043

If You Don't Have Factory Packaging Materials

If you send us your product in substandard packaging, we will charge you for factory shipping materials. If you don't have the factory packaging materials, do the following:

- 1 Select an oversized carton.
- 2 Wrap the unit in a plastic bag, and surround it with bubble-wrap.
- 3 Pack the box full of Styrofoam peanuts. Be sure there is enough clearance in the carton to protect the rack ears.

We will return the unit in Symetrix packaging.

581E

Declaration of Conformity

We, **Symetrix, Inc.**,
6408 216th St. SW, Mountlake Terrace, Washington, USA,
declare under our sole responsibility that the product:

581E Distribution Amplifier (4x4)

to which this declaration relates,
is in conformity with the following standards:

EN 60065

Safety requirements for mains operated electronic and related apparatus for household and similar general use.

EN 50081-1

**Electromagnetic compatibility - Generic emission standard
Part 1: Residential, commercial, and light industry.**

EN 50082-1

**Electromagnetic compatibility - Generic immunity standard
Part 1: Residential, commercial, and light industry.**

The technical construction file is maintained at:

Symetrix, Inc.

6408 216th St. SW
Mountlake Terrace, WA, 98043
USA

The authorized representative located within the European Community is:

World Marketing Associates

P.O. Box 100
St. Austell, Cornwall, PL26 6YU, U.K.

Date of issue: April 1, 1998

Place of issue: Mountlake Terrace, Washington, USA

Authorized signature:



Dane Butcher, President, **Symetrix Incorporated.**

581E

581E

 **Symetrix**



Symetrix, Inc.

6408 216th St. SW

Mountlake Terrace, WA, 98043

USA

Tel: (425) 778-7728

Fax: (425) 778-7727

Website: <http://www.symetrixaudio.com>

Email: symetrix@symetrixaudio.com