

450 Dual Zone Priority Mixer



450

Users Guide

Table of Contents

<i>Chapter 1</i>	Introduction	1
<i>Chapter 2</i>	Operator Safety Summary	2
<i>Chapter 3</i>	Fast Setup	3
<i>Chapter 4</i>	Mic/Line Inputs	4
<i>Chapter 5</i>	Stereo Line Inputs	6
<i>Chapter 6</i>	Output Zone Master	7
<i>Chapter 7</i>	Priority Override Muting	9
<i>Chapter 8</i>	Applications	10
<i>Chapter 9</i>	Troubleshooting	12
<i>Chapter 10</i>	Specifications	13
<i>Chapter 11</i>	Warranty & Service	14
<i>Appendix A</i>	Input/Output Connections	16
<i>Appendix B</i>	Declaration of Conformity	17

Rev C.00, 6 July, 1999

Symetrix part number 53450-0C00

Subject to change without notice.

©1999, Symetrix, Inc. All right reserved.

Symetrix is a registered trademark of Symetrix, Inc.

Mention of third-party products is for informational purposes only and constitutes neither an endorsement nor a recommendation. Symetrix assumes no responsibility with regard to the performance or use of these products.

Under copyright laws, no part of this manual may be reproduced or transmitted in any form or by any means, electronic or mechanical, including photocopying, scanning, recording or by any information storage and retrieval system, without permission, in writing, from Symetrix, Inc.

 **Symetrix**
6408 216th St. SW
Mountlake Terrace, WA 98043 USA
Tel (425) 778-7728
Fax (425) 778-7727
Email symetrix@symetrixaudio.com

450

The 450 Dual Zone Priority Mixer is designed for paging and music sound systems in clubs, restaurants, hotels, conference facilities, houses of worship or anywhere multiple audio inputs must be combined and distributed. There are two mono mic/line inputs (with phantom power and low frequency filters) and four stereo line inputs. Each input may be assigned to a stereo output zone, a mono output zone or both.

Our unique hierarchical Priority Override structure permits the two mic/line inputs and the first stereo line input to mute the other (lower priority) inputs assigned to the same zone. For example, in a typical configuration, a paging microphone assigned to the stereo zone will have priority over a background music source (connected to line input 5-6) in that zone. A jukebox (connected to line input 3-4) in the same zone will have priority over the background music, but the paging signal will retain ultimate priority and force muting of both the jukebox and the background music whenever the page mic is used.

The 450's flexibility and simplicity make it the perfect choice for a wide variety of systems. By accepting audio inputs from virtually any type of audio source and selectively routing to either the mono or stereo output zone the 450 can save you time and money in the design and installation of your next project.

Of course we recommend you read this manual cover-to-cover. You'll find the answer to most of your questions inside. If you have technical questions beyond the scope of this manual contact our Customer Service Department at:

Phone: (425)778-7728
 Fax: (425)778-7727
 Email: symetrix@symetrixaudio.com

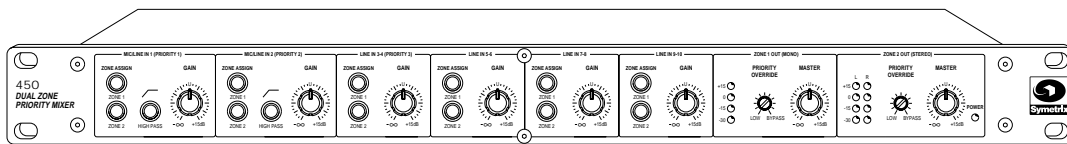

Front panel

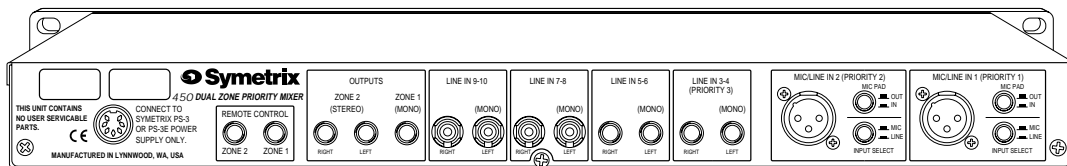

Rear panel

450

Equipment Markings

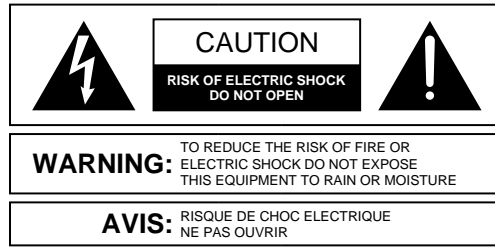

SEE OWNERS MANUAL. VOIR CAHIER D'INSTRUCTIONS.
No user serviceable parts inside. Refer servicing to qualified service personnel.
Il ne se trouve à l'intérieur aucune pièce pouvant être réparée l'utilisateur.
S'adresser à un réparateur compétent.

The lightning flash with arrowhead symbol within an equilateral triangle is intended to alert the user of the presence of uninsulated dangerous voltage within the product's enclosure that may be of sufficient magnitude to constitute a risk of electric shock to persons. The exclamation point within an equilateral triangle is intended to alert the user of the presence of important operating and maintenance (servicing) instructions in the literature accompanying the product (i.e. this manual).

Caution *To prevent electric shock, do not use the polarized plug supplied with the unit with any extension cord, receptacle, or other outlet unless the blades can be fully inserted.*

Terms

Several notational conventions are used in this manual. Some paragraphs may use **Note**, **Caution**, or **Warning** as a heading. Certain typefaces and capitalization are used to identify certain words. These are:

Note	Identifies information that needs extra emphasis. A Note generally supplies extra information to help you to better use the 450.
Caution	<i>Identifies information that, if not heeded, may cause damage to the 450 or other equipment in your system.</i>
Warning	Identifies information that, if ignored, may be hazardous to your health or that of others.
CAPITALS	Controls, switches or other markings on the 450's chassis.
Boldface	Strong emphasis.

Important Safety Instructions

Please read and keep these instructions. Heed and follow all warnings and instructions. Install in accordance with the manufacturer's instructions.

Power Source This product is intended to operate from a power source that does not apply more than 250V rms between the power supply conductors or between either power supply conductor and ground. A protective ground

connection, by way of the grounding conductor in the power cord, is essential for safe operation.

Grounding The chassis of this product is grounded through the grounding conductor of the power cord. To avoid electric shock, plug the power cord into a properly wired receptacle before making any connections to the product. A protective ground connection, by way of the grounding conductor in the power cord, is essential for safe operation. **Do not defeat the safety purpose of the grounding plug.** The grounding plug has two blades and a third grounding prong. The third prong is provided for your safety. When the provided plug does not fit your outlet, consult an electrician for replacement of the obsolete outlet.

Danger from Loss of Ground If the protective ground connection is lost, all accessible conductive parts, including knobs and controls that may appear to be insulated, can render an electric shock.

Proper Power Cord Use only the power cord and connector specified for the product and your operating locale. Use only a cord that is in good condition. **Protect the power cord** from being walked on or pinched, particularly at plugs, convenience receptacles, and the point where they exit from the apparatus.

Operating Location Do not operate this equipment under any of the following conditions: explosive atmospheres, in wet locations, in inclement weather, improper or unknown AC mains voltage, or if improperly fused. Do not install near any heat source such as radiators, heat registers, stoves, or other apparatus (including amplifiers) that produce heat. Unplug this apparatus during lightning storms or when unused for long periods of time.

Stay Out of the Box To avoid personal injury (or worse), do not remove the product covers or panels. Do not operate the product without the covers and panels properly installed. Only use accessories specified by the manufacturer. Clean only with a damp cloth.

User-serviceable parts There are no user serviceable parts inside the 450. In case of failure, refer all servicing to the factory. Servicing is required when the 450 has been damaged in any way, such as when a power supply cord or plug is damaged, liquid has been spilled or objects have fallen into the apparatus, the apparatus has been exposed to rain or moisture, does not operate normally, or has been dropped.

450

If you're in a hurry to get the 450 into your sound system and don't have time to thoroughly read this manual, the following steps will probably be enough to get you started:

1. Turn all front panel gain controls down.
2. Make sure all Zone Assign buttons are OUT.
3. Connect the 450 to AC power.
4. Set all back panel switches in correct position. Take extra care to set the Mic/Line switch (found on Inputs 1 and 2 only) in the appropriate position.
5. Connect all the audio inputs and outputs you need.
6. Set BOTH Priority Override adjustments to BYPASS. To use this feature, see Priority Override Muting in the Operations section of this manual.
7. Assign the inputs to appropriate zones, set the Zone Out Master to 12:00 (unity gain), and turn up each input until the sound source is at the desired loudness.
8. Now read the rest of this manual.

450

Front Panel

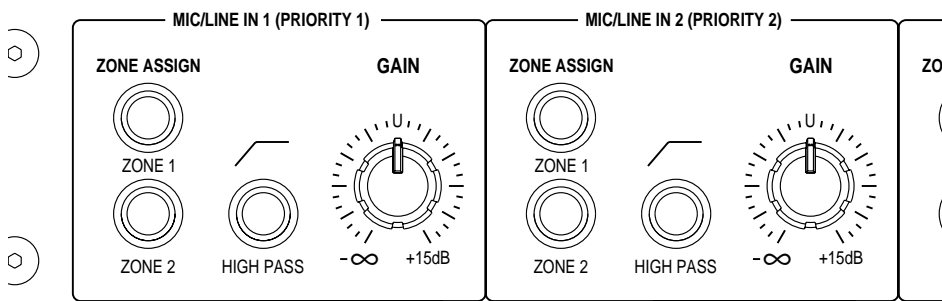

Zone Assign - Any input can be assigned to either the mono or stereo output zone, or both, or neither. When either Mic/Line input is assigned to the stereo output zone, both left and right will be driven by the same signal. For the best signal to noise performance, leave the input unassigned if not in use.

Highpass Filter - 12dB/Oct LF rolloff. 3dB down at 115 Hz. Use this to eliminate excessive p-popping or room rumble from paging/announce mics. Even if you don't notice a problem, try pushing this switch anyway. It increases the efficiency of systems using ceiling mounted speakers of the 70V variety, because it removes low frequency material that the speakers probably can't reproduce anyway. It will help your amplifier to run cooler, draw less power, and just maybe it will help to extend the life of the speaker.

Channel Gain Control - Gain range is -infinity to +15dB. Unity gain (indicated by the U symbol on the front panel) at 12:00 position. This is no ordinary volume control. Well, actually it is.

450

Rear Panel

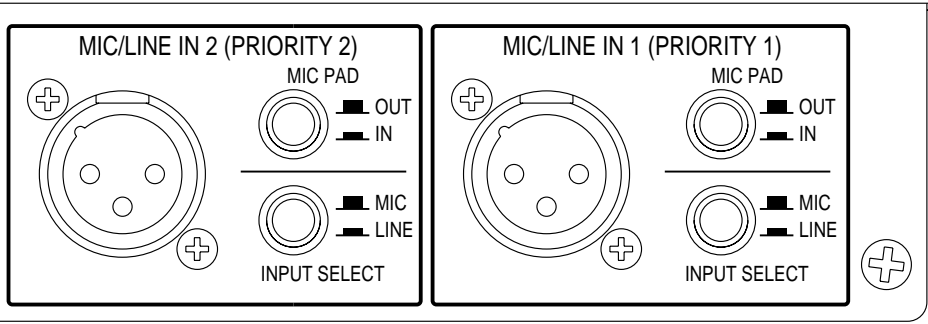

XLR Input Jack - In order to fit all the inputs and outputs onto the 450's rear panel, we combined the Mic/Line Input jacks into one balanced XLR connector that can handle both. This jack is wired as follows:

Pin 1 = (ground, shield)

Pin 2 = (high, +)

Pin 3 = (low, -)

Most low impedance, balanced microphones (and many line level sources) can plug directly into these jacks, but some sources will require adapters. See the chart in Appendix A for examples.

Caution *Do not attempt to connect a high impedance, unbalanced microphone (these usually, but not always, have a 1/4" phone jack attached to them) to either Mic/Line input unless you first disconnect the phantom power.*

INPUT SELECT Switch - Push this switch in to accommodate line level sources such as PBX paging outputs, mixing consoles, automated emergency announce systems, etc. This bypasses the mic preamp circuit and disconnects phantom power from the XLR connector.

Note Make sure the Mic/Line input is not assigned to either Zone Output when you push the Mic/Line switch because the phantom power may cause a slight pop.

In the mic (out) position, the input signal is routed through the mic preamp and the phantom power is engaged. The preamp stage delivers approximately 40 dB of gain.

Warning **Do not put this switch into the Mic position when feeding a line level signal into this input** (unless you enjoy re-coning speakers).

MIC PAD Switch - This decreases the gain of the mic preamp by 20 dB. Engage this switch if the mic level signal source tends to overload the input preamp stage, or you notice that the incoming signal is so hot that you have to run the Channel Gain knob really low. Typically, this happens when using high output condenser mics, or handheld, close-talked mics. As the name Mic Pad suggests, this switch does not affect the input gain when the channel is operating in Line mode.

Phantom Power - Phantom power is applied to the Mic/Line input only when the mic/line switch is in the mic (in) position. If you want to completely disconnect the phantom power, please contact Symetrix Customer Service.

450

Front Panel

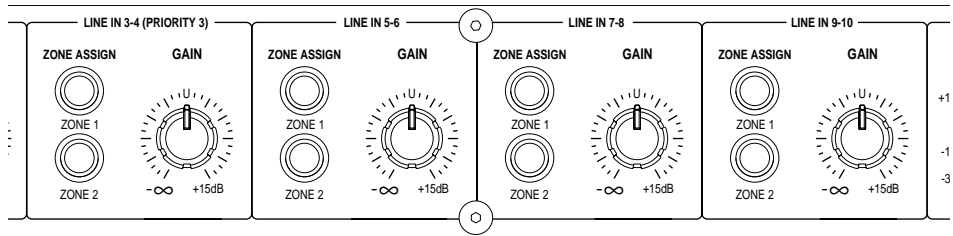

Zone Assign - As you might expect, the Left and Right input signals are summed when fed to the Zone 1 (mono) output. This is done independently of the Zone 2 (Stereo) feed, which keeps the signals separate. As with the Mic/Line inputs, maximize the unit's signal-to-noise ratio by leaving all unused inputs unassigned.

Channel Gain - The wide gain range of this control (-infinity to +15dB) accommodates the variety of input levels generically known as line level, including tape decks, CD players, console feeds, etc. Unity gain is indicated by the u symbol on the front panel.

Rear Panel

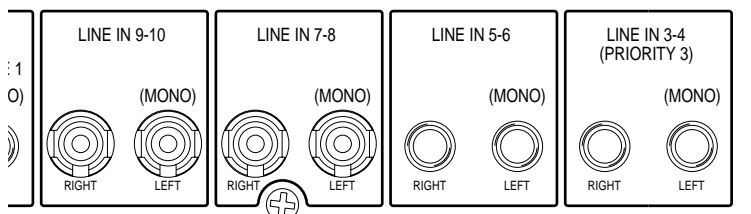

Input Jacks - Line inputs 3-6 are equipped with 1/4", TRS (tip-ring-sleeve), balanced, phone jacks. They are wired as follows:

- Tip = (high, +)
- Ring = (low, -)
- Sleeve = (ground, shield)

Line inputs 7-10 are unbalanced RCA-phono type jacks. They are wired as follows:

- Tip = (high, +)
- Sleeve = (ground, shield)

Though you'll be able to plug most line level outputs directly into the 450, some sources may need adapters. See Appendix A for proper wiring.

Mono/Stereo Operation - Line Inputs 3-10 are arranged in stereo pairs; each pair is assigned to a single gain control on the front panel. If you want to use one of these inputs with a mono source, just insert a single plug into the jack labeled Left (mono) and leave the Right jack unconnected. The left jack will automatically feed both the left and right channels of the Zone 2 (stereo) output.

450

Front Panel

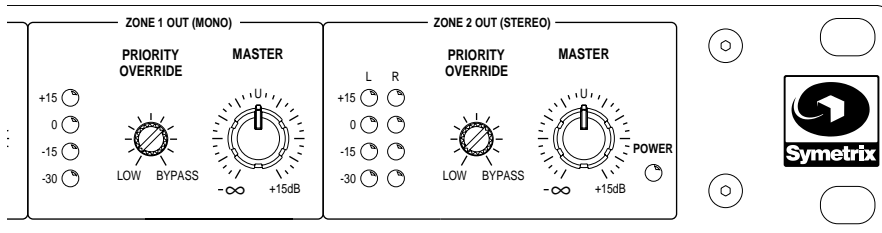

Output Jacks - The 450's outputs are electronically balanced, low-impedance, and capable of driving a balanced input to +22dBu. The output connectors are 1/4" Tip-Ring-Sleeve and you can find wiring and adapter examples in Appendix A.

Master Gain Controls These controls have the same gain range as the input channel gain controls -infinity to +15dB. The U symbol at the knob's 12:00 position indicates unity gain when the 450's output is driving a balanced input. The 450 uses a differential output driver that drops the output level by 6db when connected to an unbalanced input. This does not adversely affect the audio quality whatsoever and is easily fixed by increasing the output gain knob setting by 6dB.

Rear Panel

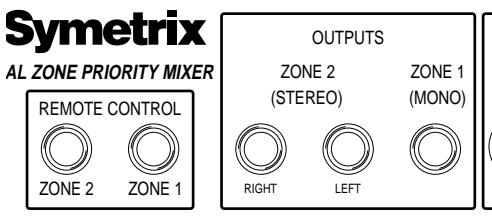

Remote Control - There are two ways to externally control the volume of the 450's Zone Outputs. Both options render the front panel master gain control inactive.

Option #1 - The easiest method is the old volume-knob-in-a-wall-plate. Use a 50k linear potentiometer and wire it as follows on the next page in diagrams 1 or 2.

The remote control cable is not carrying any audio signal, just DC control voltage. This means that you can use a very long cable (up to 1000') without degrading the 450's performance whatsoever. To achieve this, you must use 20-22 gauge, three conductor plus ground cable and wire it according to diagram 2.

Option #2 - If you're using a programmable remote control system that has the ability to supply an external voltage to the 450, no problemo. Wire it as seen in Diagrams 3 or 4 on the following page.

The dB/Voltage gain scale is 5dB/V, Unity gain = 11.5V. Note that the +15V control voltage supplied by the 450 (on the tip of the TRS connector) is not used in this configuration. This is okay, it won't hurt anything. In fact, you can save a little money on your remote cable by using one conductor plus ground for short cable runs (see diagram 3) or two conductor plus ground for long runs (see diagram 4).

Remote Control Wiring

Diagram 1

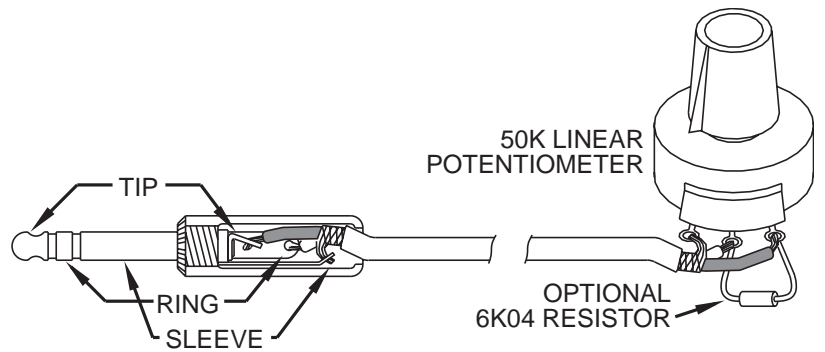

Diagram 2

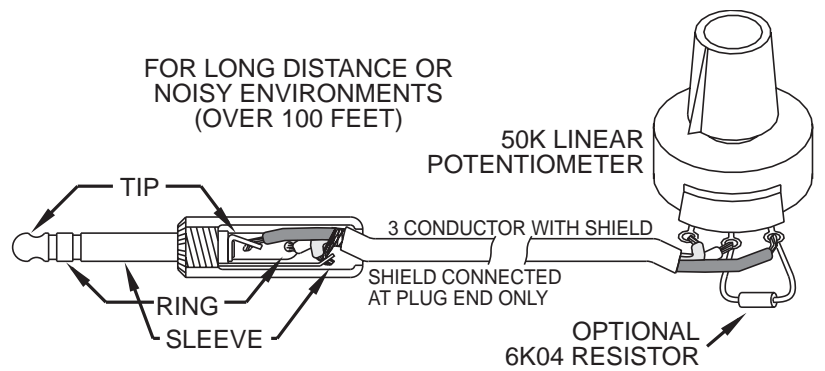

Diagram 3

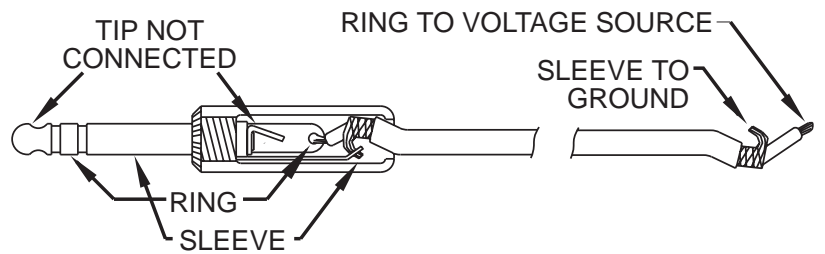
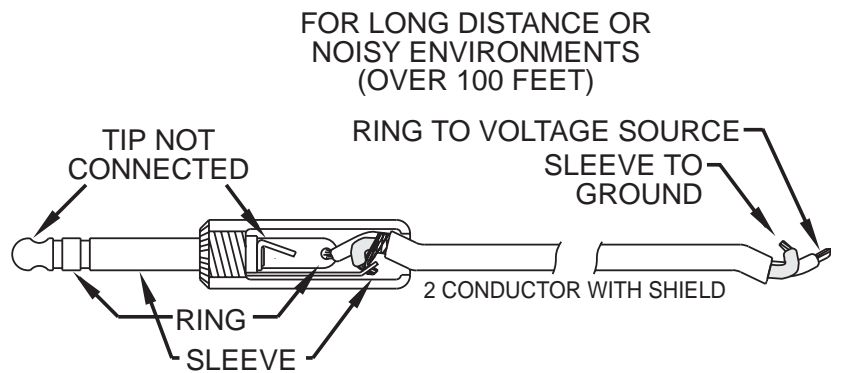

Diagram 4



450

Priority Levels - The term priority override refers to the 450's ability to selectively mute it's low priority inputs when audio signal is present on it's high priority inputs. There are actually four different levels of priority, assigned as follows:

Input	Priority Level
Mic/Line In 1	Priority One (highest)
Mic/Line In 2	Priority Two (not so high)
Line In 3-4	Priority Three (even lower)
Line In 5-6, 7-8, 9-10	No priority

When audio is detected on a Priority input, all inputs with a lower Priority Level will mute until audio is no longer detected on the higher Priority Level input (see the diagram below). It is important to note that the Priority Override Muting function is directly linked to an input's zone assignment.

Priority Override Adjustment - This control is the trim adjustment found next to each Zone Out Master level control on the 450's front panel (see the front panel drawing on page 7). It varies the trigger threshold of the Priority Override muting function. i.e. The muting function activates when the audio level on a Priority channel exceeds this setting. To disable the Override function for either Zone Out, set the trim control to the Bypass position.

Note We recommend that you set the trigger threshold as low as possible if you are using one music source to mute another. An example of this is a restaurant/bar system that uses a CD jukebox to automatically mute the TV/video feed. A low threshold will prevent the low priority input from un-muting during quiet musical passages.

Note In a paging system with a live (i.e. no on/off switches) paging mic, you may want to set the trigger threshold higher to prevent background noise from activating the muting function.

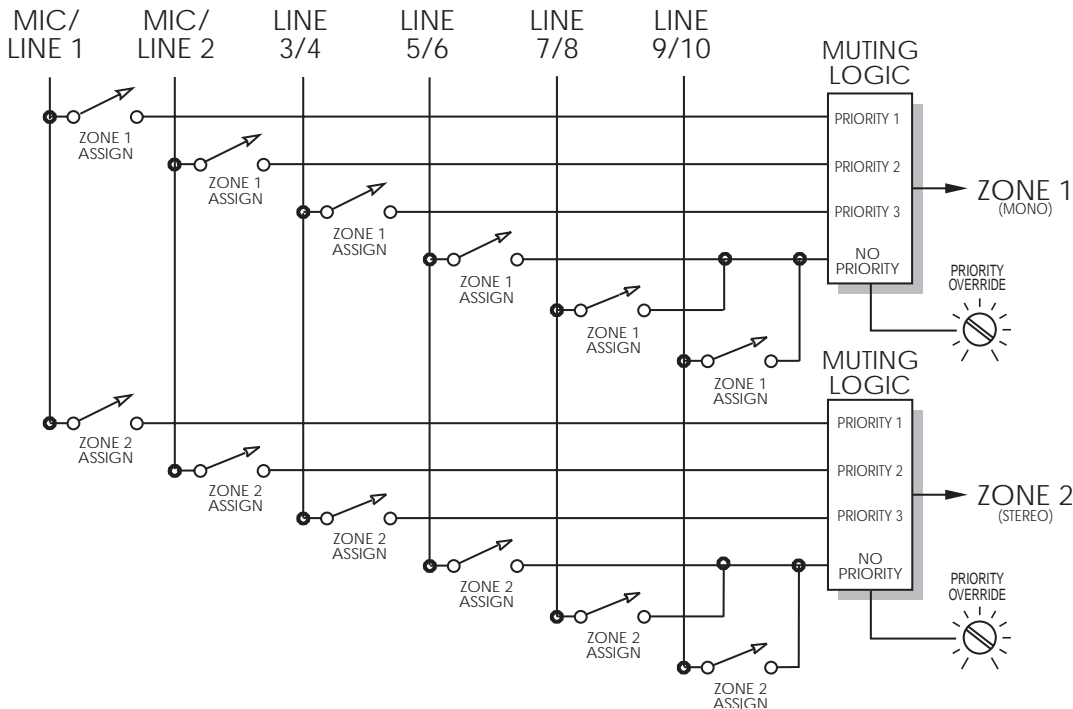

450

Two Zone Foreground Music with Paging

The following is a layout of a typical restaurant/bar combination system. When someone makes an announcement, the announce audio goes only to Zone 2 which we have drawn as a stereo sound system in the bar area. The 450 mutes only the foreground music feed to that zone, leaving the Zone 1 (the dining room) music feed live. It s like having two separate mixers in one chassis.

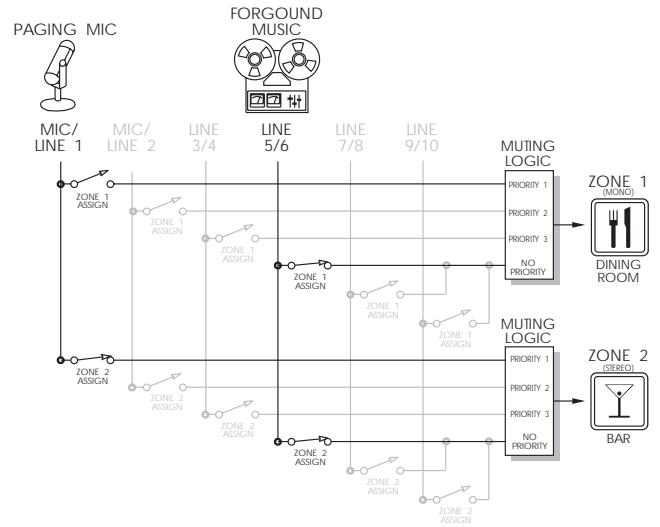

Mic and PBX Paging with Emergency Override

The reason that we included two mic/line inputs as the two top priority levels is to accommodate the needs of industrial paging systems. The following diagram shows how the Priority Override Muting system handles multiple paging sources. The paging mic overrides PBX pages. Both of these, however, are muted by the fire alarm/evacuation announce system.

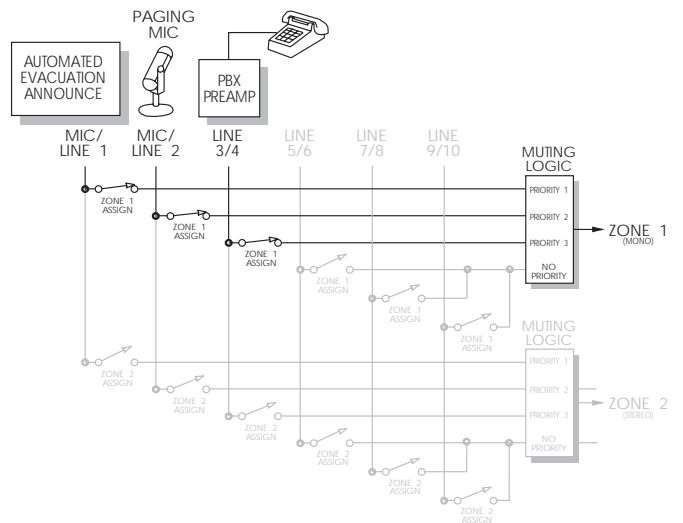

450

Meeting/Presentation Rooms with Remote Control

In meeting rooms, the 450 is flexible enough to handle both speech reinforcement and audio playback at the same time, even if you're using two separate speaker systems. In the diagram below, note that the remote control jacks allow the user to adjust the music and mic volume separately from within the meeting room.

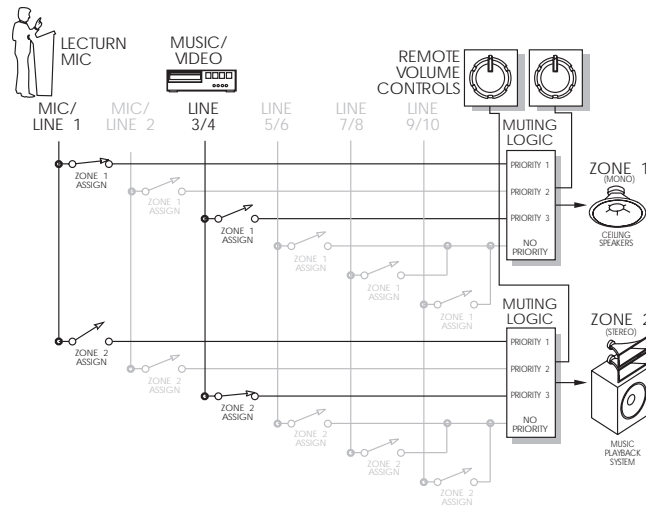

Subgrouping with Remote Control

In the following diagram, we present an idea that you will find useful in hotels and convention centers. The music sources (inputs 5-10) are assigned only to the zone 1 output. A patch cord connects this output to Line Input 3, which is assigned **only** (this is important) to Zone 2. The Zone 2 output is then fed to the amplifier's that drive the speakers. A remote control, conveniently located near the paging mic, is connected to the Zone 1 output. This configuration gives the staff convenient control over the music volume but leaves the paging volume untouched. This can be especially useful in systems where the staff wants control over the background music volume, but the automated emergency announce system must always be heard.

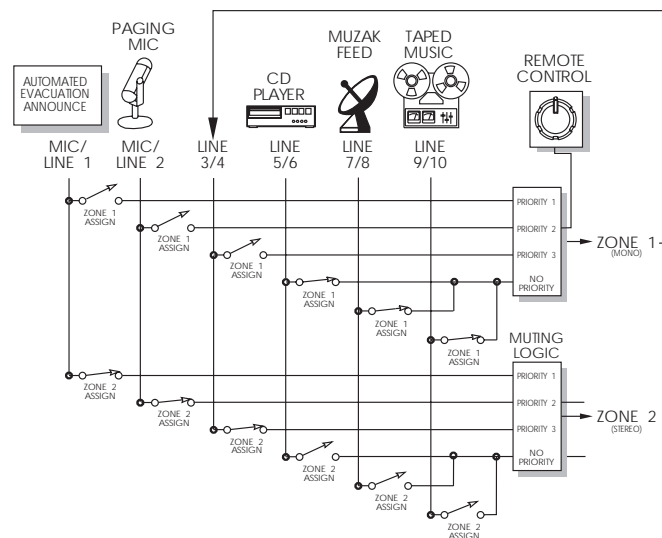

450

There is no output signal:

- Check the AC power connections to the 450.
- Check input and output cables and connections.
- Determine that there really is a signal coming from the source and that it is getting to the 450.
- Make sure that the input signal is assigned to Zone 1 or Zone 2 or both.

Distortion in the output signal:

- Check the input signal. Is it overdriving the 450's input? If so, reduce the incoming signal level or, in the case of microphone signals, use the 450's microphone pad.
- Is the incoming signal already distorted? Listen up stream from the 450 to determine that you are feeding it a clean signal(s).

Buzz in the output:

- Check input and output connector wiring.
- Check for ground loops between interconnected system equipment.
- Are all system components on the *same* AC ground?

Noise (hiss):

- Check input signal levels and input level control settings. The input may be too low in level. If so, boost the incoming signal if possible. If the incoming signal is Mic level, make sure that the Mic/Line Switch for that input is set to Mic .
- Is the input signal already noisy? Listen up stream from the 450 to determine that you are feeding it a clean signal(s).

The 450 doesn't power up or doesn't respond properly:

- Consult a qualified service technician or the Symetrix factory.

450

Architects and Engineers Specifications

The audio microphone and line mixer shall be a high performance unit occupying a single rack space (1U).

The unit shall have two low impedance, balanced microphone/line inputs with connection via female XLR. Each microphone/line input shall have a rear panel pushbutton which shall bypass the mic preamp circuitry. Each input shall also have a switch to reduce the gain of the mic input by 20dB. Associated with each microphone input shall also be a front panel level control potentiometer whose purpose is to establish the level of the microphone channel as it is mixed to either a mono output zone, a stereo output zone, or both simultaneously. Each microphone input shall also have a first order low cut filter with a 115Hz rolloff frequency.

The mic/line mixer shall have four stereo, line level inputs. Each input shall be assignable to either a monaural output zone, a stereo output zone, or both. Associated with each line input shall be a level control potentiometer whose purpose is to establish the level of the line level output signal as it is mixed to either a mono output zone, a stereo output zone, or both simultaneously.

The 450 shall incorporate a four level priority muting system as follows. High priority inputs shall mute or duck all lower priority inputs that are assigned to the same output zone when audio is present at the higher priority input. There shall be a threshold control in each zone master section which determines the minimum level of audio that will trigger the muting/ducking function. Priority shall be assigned as follows: Mic/Line In 1 — Priority 1, Mic/Line In 2 — Priority 2, Line In 3-4 — Priority 3, Line In 5-6, 7-8, 9-10 — No Priority.

Independent master output level controls shall be provided for both the monaural output zone and the stereo output zone. LED peak meters shall indicate the actual output level regardless of the nature of the load.

Independent means shall be provided to remotely control the output level of the mono output zone and the stereo output zone. Rear panel jacks shall be provided to accept connections from standard 50K linear potentiometers for this purpose. When wired for remote control, the front panel output zone level controls shall be disabled.

The mic/line mixer shall be a Symetrix, Inc. model 450 Dual Zone Priority Mixer.

Specifications

Audio	
Microphone Inputs	Two, Low Impedance, Balanced
Mic Common Mode Rejection @ 1 kHz, 1V RMS	>85 dB
Phantom Power	+24V (10ma per input max)
Line Inputs	Four, Stereo
Line Input Impedance	>10k Ohms, Balanced
Line Input Common Mode Rejection @ 1 kHz, 1V RMS	>40 dB
Maximum Line Input Level	+24 dBu Balanced, +18 dBu Unbalanced
Frequency Response, Any Input to Any Output	±1 dB, 20 Hz to 20 kHz

Connections	
Microphone Inputs	XLR Female (pin 2 high)
Line Inputs	1/4" TRS (tip is high), RCA-phono (Unbalanced)
Line Outputs	1/4" TRS (tip is high)
Remote Volume Control Inputs	1/4" TRS

Physical

Size (hwd)	1.72 x 19 x 6.5 inches, 4.37 x 48.26 x 16.51 centimeters
Weight	8 lbs (3.64kg) net

Electrical

Power requirements	117V nominal, 95 to 130V AC, 50 to 60 Hz, 15 watts
	230V nominal, 165 to 255V AC, 50 Hz, 15 watts

Note: The maximum operating ambient temperature is 25 degrees C.

Specifications subject to change without notice.

450

Warranty

Following are the terms and limitations of the Symetrix warranty.

Symetrix, Inc. expressly warrants to the original purchaser (Buyer), subject to the terms and conditions set forth below, that the Product will be free from defects in material and workmanship as a result of normal commercial use for eighteen (18) months from the date of shipment.

Some Symetrix products contain embedded software and may also be accompanied by control software intended to be run on a personal computer. Said software is specifically excluded from this warranty.

Symetrix's warranty obligation is limited to the repair, replacement, or refund at Symetrix's sole discretion, of the part or parts of the Product which may thus prove defective in materials or workmanship within one year from date of purchase under normal use and which our examination discloses to our satisfaction to be thus defective, provided that Buyer gives Symetrix prompt notice of its warranty claim and satisfactory proof thereof.

Symetrix will make every reasonable effort to ensure that parts are available to support the repair of our products under warranty. In the event that a product or component part thereof becomes obsolete, unavailable or irreparable, Symetrix reserves the right to refund a prorated portion of the purchase price in full satisfaction of all warranty claims.

In order to serve you better we require that the Buyer shall, prior to shipping Product to Symetrix for warranty service, contact Symetrix and secure a Return Authorization Number that shall be included with the returned Product. This will facilitate our efforts to keep track of your Product and process your warranty repair as quickly as possible. Buyer will prepay all freight charges to ship the Product to Symetrix for warranty inspection and service. This warranty is subject to Symetrix's inspection of the Product at its facilities and, upon Symetrix's request, satisfactory proof of purchase (dated copy of original retail dealer's invoice.)

Symetrix reserves the right to effect repairs to the product with reconditioned components/parts. Products once repaired under warranty will be shipped to Buyer freight prepaid by Symetrix via United Parcel Service (surface) or any similar shipper, to any location designated by buyer within the Continental United States. At Buyer's request and expense Product will be returned via airfreight. Outside the continental United States, repaired or replaced products will be returned freight collect.

THIS WARRANTY IS EXPRESSLY IN LIEU OF ALL OTHER WARRANTIES EXPRESS OR IMPLIED, ARISING BY LAW OR OTHERWISE (INCLUDING, WITHOUT LIMITATION ANY OBLIGATIONS OF THE SELLER WITH RESPECT TO CONSEQUENTIAL DAMAGES) INCLUDING THE WARRANTIES OF MERCHANTABILITY AND FITNESS FOR USE AND OF ALL OTHER OBLIGATIONS OR LIABILITIES ON OUR PART, AND WE NEITHER ASSUME, NOR AUTHORIZE ANY OTHER PERSON TO ASSUME FOR US, ANY OTHER LIABILITY IN CONNECTION WITH THE SALE OF THE PRODUCT. THIS WARRANTY SHALL NOT APPLY TO THIS PRODUCT OR ANY PART THERE OF WHICH HAS BEEN SUBJECT TO ACCIDENT, NEGLIGENCE, ALTERATION, ABUSE, OR MISUSE. WE MAKE NO WARRANTY WHATSOEVER IN RESPECT TO ACCESSORIES OR PARTS NOT SUPPLIED BY US. THE TERM ORIGINAL PURCHASER, AS USED IN THIS WARRANTY SHALL BE DEEMED TO MEAN THAT PERSON OR COMPANY THAT ORIGINALLY PURCHASED THE PRODUCT.

This Symetrix product has been designed and manufactured for use in professional/industrial systems and is not intended for other usage. This warranty only applies to Buyers using the Product in professional/industrial systems. With respect to others, including but not limited to consumers for personal, family, or household use, Symetrix expressly disclaims all warranties, including but not limited to warranties of merchantability and fitness for a particular purpose and the express warranties as otherwise provided herein.

Symetrix reserves the right to modify the design or make additions to, or improvements to, its product lines without making similar upgrades to Product purchased by Buyer. Symetrix does not authorize any third party, including any dealer or sales representative, to assume any liability, effect any repairs or modifications to the Product, or make any additional warranties or representation regarding the Product or Product information on behalf of Symetrix.

Symetrix's total liability on any claim, whether in contract, tort (including negligence) or otherwise arising out of, connected with, or resulting from the manufacture, sale, delivery, resale, repair, replacement or use of Product will not exceed the purchase price of the Product or any part thereof which gives rise to the claim. In no event will Symetrix be liable for any incidental or consequential damages including but not limited to damage for lost revenue, cost of capital, claims of customers for service interruptions or failure to supply, and costs and expenses incurred in connection with labor, overhead, transportation, installation or removal of products or substitute facilities or supply houses as a result of Product failure.

This limited warranty gives Buyer certain rights. Buyer may have additional rights under applicable law.

450

Servicing the 450

If you have determined that your 450 requires repair services and you live *outside* of the United States, please contact your local Symetrix dealer or distributor for instructions on how to obtain service. If you reside in the U.S. then proceed as follows:

Before sending anything to Symetrix, contact our Customer Service Department for a return authorization (RA) number. The telephone number is (425) 778-7728 or email: tech@symetrixaudio.com

In-warranty Repairs

To get your 450 repaired under the terms of the warranty:

1. Call us for an RA number.
2. Pack the unit in its original packaging materials.
3. Include your name, address, daytime telephone number, and a brief statement of the problem.
4. Write the RA number on the outside of the box.
5. Ship the unit to Symetrix, freight prepaid.

We do *not* accept freight collect shipments.

Repairs made in-warranty will cost you only one-way freight charges. We'll prepay the return (surface) freight.

If you send us your product in substandard packaging, we will charge you for factory shipping materials. If you don't have the factory packaging materials, please use an oversized carton, wrap the unit in a plastic bag, and surround it with bubble-wrap. Pack the box full of Styrofoam peanuts. Be sure there is enough clearance in the carton to protect the rack ears (you wouldn't believe how many units are returned with bent ears). We will return the unit in Symetrix packaging. Of course, if the repair is due to operator error, parts and labor will be charged. In any event, if there are charges for the repair costs, you will pay for the return freight. All charges will be COD unless you have made other arrangements (prepaid, Visa or Mastercard).

Out-of-warranty Repairs

If the warranty period has passed, you'll be billed for all necessary parts, labor, packaging materials, and freight charges. Please remember, you must call for an RA number before sending the unit to Symetrix.

450

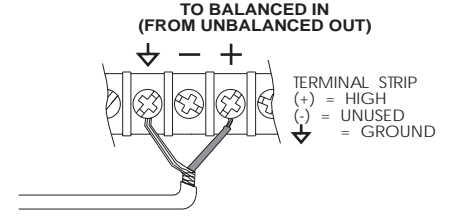
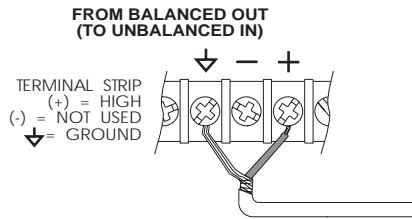
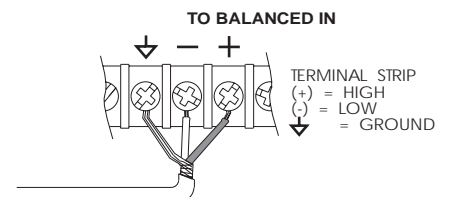
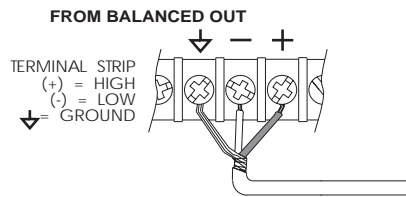
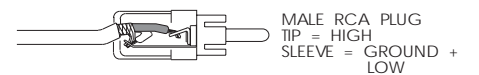
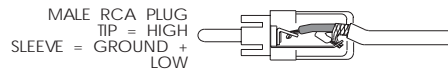
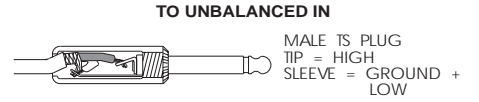
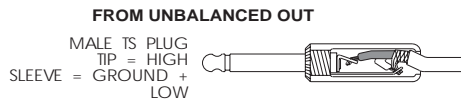
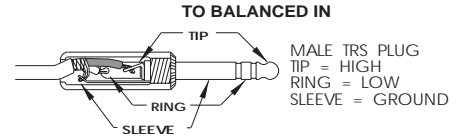
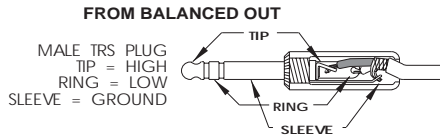
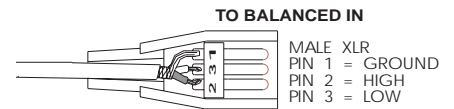
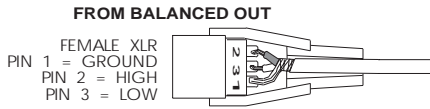

**FROM ELECTRONIC, NON-TRANSFORMER
BALANCED OUTPUT (TYPICAL OF SYMETRIX PRODUCTS)
TO UNBALANCED INPUTS**

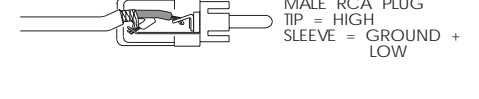
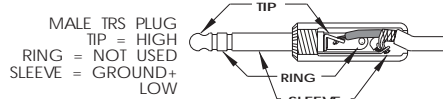
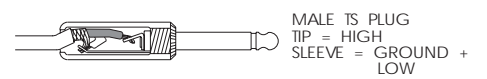

450

Declaration of Conformity

We, **Symetrix Incorporated**, 6408 216th St. SW, Mountlake Terrace, Washington, USA,
declare under our sole responsibility that the product:

450 Dual Zone Priority Mixer

to which this declaration relates, is in conformity with the following standards:

EN 60065
Safety requirements for mains operated electronic and related
apparatus for household and similar general use.

EN 50081-1
Electromagnetic compatibility - Generic emission standard
Part 1: Residential, commercial, and light industry.

EN 50082-1
Electromagnetic compatibility - Generic immunity standard
Part 1: Residential, commercial, and light industry.

The technical construction file is maintained at:

Symetrix, Inc.
6408 216th St. SW
Mountlake Terrace, WA, 98043
USA

The authorized representative located within the European Community is:

World Marketing Associates
P.O. Box 100
St. Austell, Cornwall, PL26 6YU, U.K.

Date of issue: 1 November 1995

Place of issue: Mountlake Terrace, Washington, USA

Authorized signature:



Dane Butcher, President, **Symetrix Incorporated**.

450

450

450

450

 **Symetrix**



Symetrix, Inc.

6408 216th St. SW

Mountlake Terrace, WA, 98043

USA

Tel: (425) 778-7728

Fax: (425) 778-7727

Website: <http://www.symetrixaudio.com>

Email: symetrix@symetrixaudio.com