



606

DELAY F/x MACHINE

Flowchart

(X) = PARAMETER NUMBER
 (X) = PARAMETER NUMBER (ALSO FRONT PANEL CONTROL)
 NOTE: PARAMETER NUMBER +20 IS EQUAL TO THE MIDI CONTINUOUS CONTROLLER NUMBER

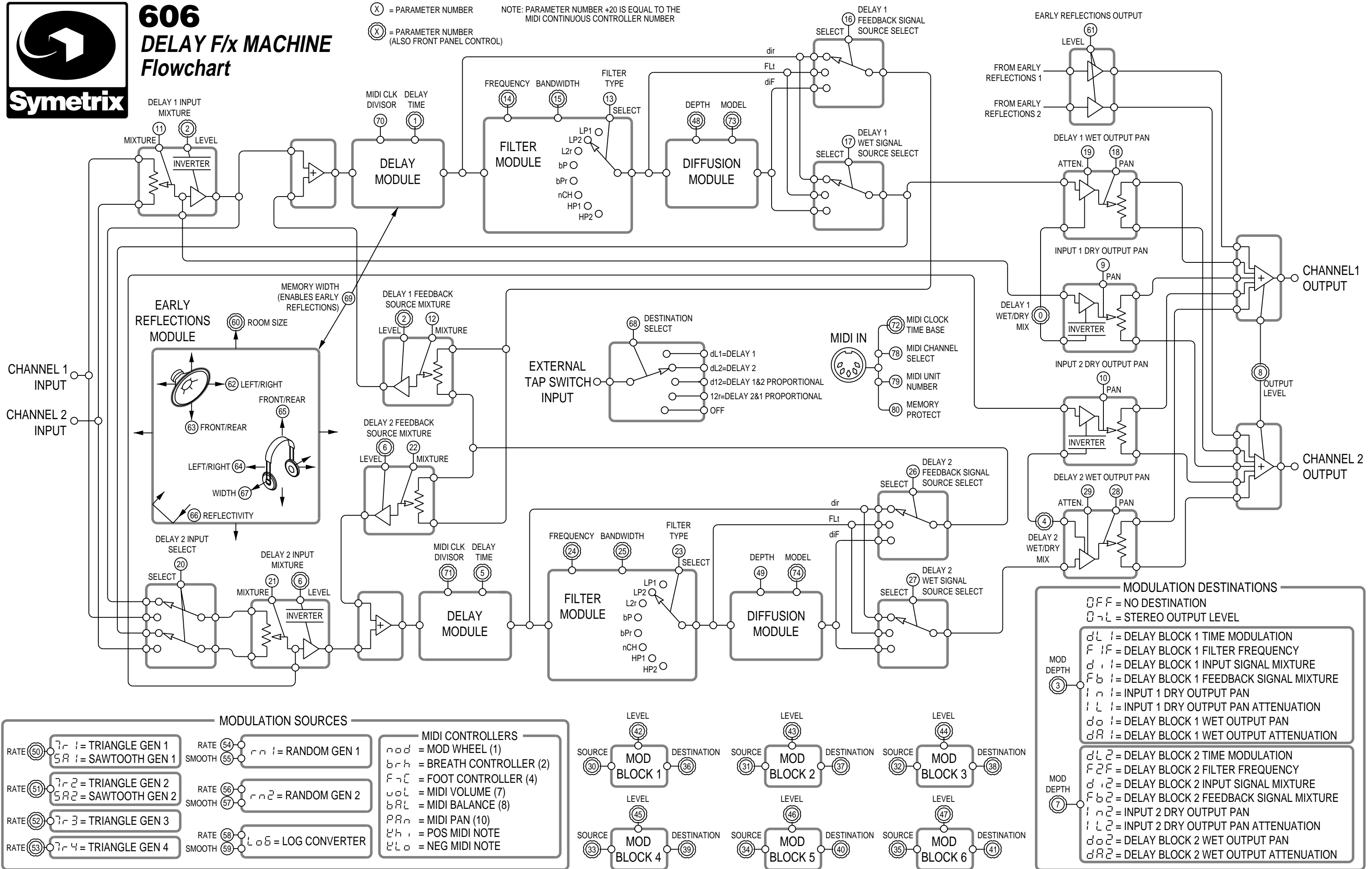

CHANNEL 1 INPUT
 CHANNEL 2 INPUT

CHANNEL 1 OUTPUT
 CHANNEL 2 OUTPUT

MODULATION SOURCES

RATE (50) Δ_{r1} = TRIANGLE GEN 1	RATE (54) r_{n1} = RANDOM GEN 1	MIDI CONTROLLERS mod = MOD WHEEL (1) brh = BREATH CONTROLLER (2) frc = FOOT CONTROLLER (4) vol = MIDI VOLUME (7) bal = MIDI BALANCE (8) pan = MIDI PAN (10) ph = POS MIDI NOTE pl = NEG MIDI NOTE
RATE (51) Δ_{r2} = TRIANGLE GEN 2	RATE (56) r_{n2} = RANDOM GEN 2	
RATE (52) Δ_{r3} = TRIANGLE GEN 3	RATE (58) log = LOG CONVERTER	
RATE (53) Δ_{r4} = TRIANGLE GEN 4	RATE (59) log = LOG CONVERTER	

LEVEL (42)	SOURCE (30)	DESTINATION (36)	LEVEL (43)	SOURCE (31)	DESTINATION (37)	LEVEL (44)	SOURCE (32)	DESTINATION (38)
MOD BLOCK 1			MOD BLOCK 2			MOD BLOCK 3		
LEVEL (45)	SOURCE (33)	DESTINATION (39)	LEVEL (46)	SOURCE (34)	DESTINATION (40)	LEVEL (47)	SOURCE (35)	DESTINATION (41)
MOD BLOCK 4			MOD BLOCK 5			MOD BLOCK 6		

MODULATION DESTINATIONS

OFF = NO DESTINATION
 0-1 = STEREO OUTPUT LEVEL

MOD DEPTH (3)

- $dL1$ = DELAY BLOCK 1 TIME MODULATION
- $F1F$ = DELAY BLOCK 1 FILTER FREQUENCY
- $d1i$ = DELAY BLOCK 1 INPUT SIGNAL MIXTURE
- $Fb1$ = DELAY BLOCK 1 FEEDBACK SIGNAL MIXTURE
- $i1n$ = INPUT 1 DRY OUTPUT PAN
- $i1L$ = INPUT 1 DRY OUTPUT PAN ATTENUATION
- $do1$ = DELAY BLOCK 1 WET OUTPUT PAN
- $dR1$ = DELAY BLOCK 1 WET OUTPUT ATTENUATION

MOD DEPTH (7)

- $dL2$ = DELAY BLOCK 2 TIME MODULATION
- $F2F$ = DELAY BLOCK 2 FILTER FREQUENCY
- $d2i$ = DELAY BLOCK 2 INPUT SIGNAL MIXTURE
- $Fb2$ = DELAY BLOCK 2 FEEDBACK SIGNAL MIXTURE
- $i2n$ = INPUT 2 DRY OUTPUT PAN
- $i2L$ = INPUT 2 DRY OUTPUT PAN ATTENUATION
- $do2$ = DELAY BLOCK 2 WET OUTPUT PAN
- $dR2$ = DELAY BLOCK 2 WET OUTPUT ATTENUATION