

3CCD
COLOR VIDEO CAMERA

Command List

B R C -300/ P

VISCA¹⁾ RS-232C/RS-422 Commands

Use of RS-232C/RS422 control software which has been based upon this commands list may cause malfunction or damage to hardware and software. Sony Corporation is not liable for any such damage.

Overview of VISCA

In VISCA, the side outputting commands, for example, a computer, is called the controller, while the side receiving the commands, such as an BRC-300/P, is called the peripheral device. The BRC-300/P serves as a peripheral device in VISCA. In VISCA, up to seven peripheral devices like the BRC-300/P can be connected to one controller using communication conforming to the RS-232C/RS422 standard. The parameters of RS-232C/422 are as follows.

- Communication speed: 9600 bps/38400 bps
- Data bits: 8
- Start bit: 1
- Stop bit: 1
- Non parity

Flow control using XON/XOFF and RTS/CTS, etc., is not supported.

Peripheral devices are connected in a daisy chain. As shown in Fig. 1, the actual internal connection is a one-direction ring, so that messages return to the controller via the peripheral devices. The devices on the network are assigned addresses.

The addresses of peripheral devices are as follows.

<The address of the controller is fixed at 0>

The addresses of the peripheral devices are 1, 2, 3 ... in order, starting from the one nearest the controller.

<The address of the controller is fixed at 1 through 7 >

The addresses of the peripheral devices will set on a preselected number. Within a single system, the number can be used only once. Usage of the address-switch number other than 0, change BRC-300/P address-switch not to duplicate detail beforehand.

Fig. 1 VISCA network configuration

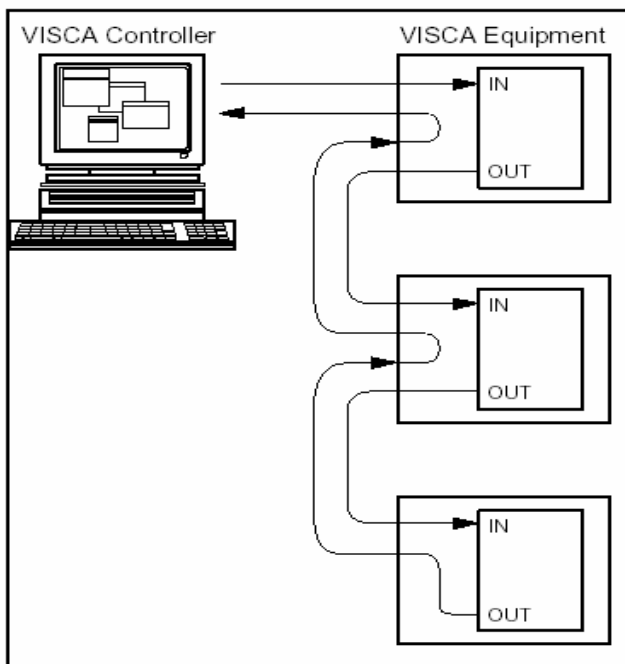

The VISCA devices each have a VISCA IN and VISCA OUT connector. Set the DTR input (the S output of the controller) of VISCA IN to H when controlling VISCA equipment from the controller.

1) VISCA is a protocol which controls consumer camcorders developed by Sony. "VISCA" is a trademark of Sony Corporation.

VISCA Communication Specifications

VISCA packet structure

The basic unit of VISCA communication is called a packet (Fig.2), The first byte of the packet is called the header and comprises the sender's and receiver's addresses. For example, the header of the packet sent to the BRC-300/P assigned address 1 from the controller (address 0) is hexadecimal 81H. The packet sent to the BRC-300/P assigned address 2 is 82H. In the command list, as the header is 8X, input the address of the BRC-300/P at X. The header of the reply packet from the BRC-300/P assigned address 1 is 90H. The packet from the BRC-300/P assigned address 2 is A0H.

Some of the commands for setting BRC-300/P units can be sent to all devices at one time (broadcast). In the case of broadcast, the header should be hexadecimal 88H. When the terminator is FFH, it signifies the end of the packet.

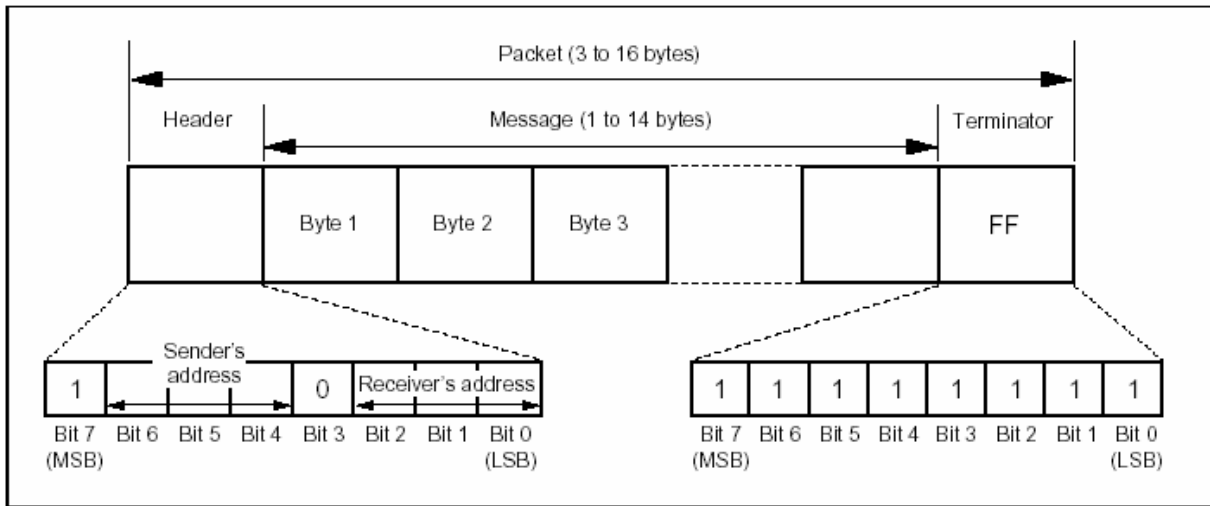

Fig. 2 Packet structure

Note

Fig. 2 shows the packet structure, while Fig. 3 shows the actual waveform. Data flow will take place with the LSB first.

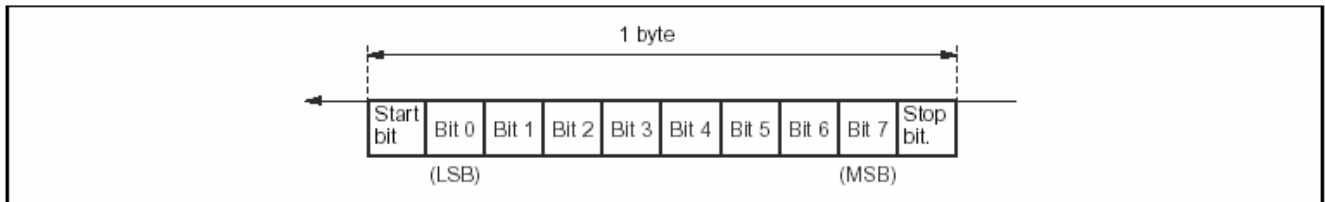
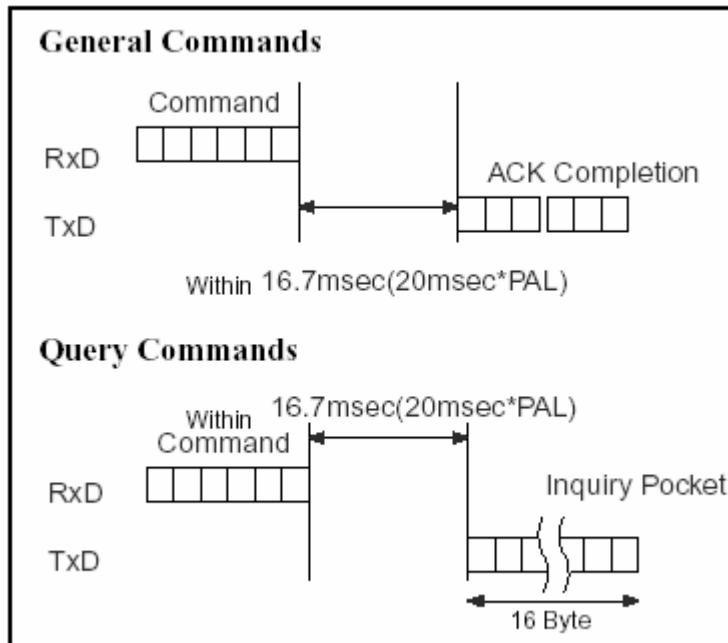

Fig. 3 Actual waveform for 1 byte.

Timing Chart

As VISCA Command processing can only be carried out one time in a Vertical cycle, it takes the maximum 1V cycle time for an ACK/Completion to be returned. If the Command ACK/Completion communication time can be cut shorter than the 1V cycle time, then every 1V cycle can receive a Command. From this point, if 2 or more commands in a row are to be sent, wait for the first command (for normal commands, an ACK or an error message, for query commands, an Inquiry Packet) to be carried out before sending the next one.



Command and Inquiry

Command

Sends operational commands to the BRC-300/P.

Inquiry

Used for inquiring about the current state of the BRC-300/P.

Command Packet Note

Inquiry 8X QQ RR ...FF QQ1) =Command/Inquiry,

RR2) =category code

1) QQ =01 (Command), 09 (Inquiry)

2) RR =00 (Interface), 04 (camera 1), 06 (Pan/Tilter)

X =1 ~ 7: BRC-300/P address

Responses for commands and inquiries

ACK message

Returned by the BRC-300/P when it receives a command. No ACK message is returned for inquiries.

Completion

Returned by the BRC-300/P when execution of commands or inquiries is completed. In the case of inquiry commands, it will contain reply data for the

inquiry after 3rd byte of the packet. If the ACK message is omitted, the socket number will contain a 0.

Reply Packet Note

Ack X0 4Y FF Y =socket number

Completion (commands) X0 5Y FF Y =socket number

Completion (Inquiries) X0 5Y ...FF Y =socket number

X =9 ~ F: BRC-300/P address + 8

Error message

When a command or inquiry command could not be Executed or failed, an error message is returned.

Error Packet Description

X0 6Y 01 FF Message length error

X0 6Y 02 FF Syntax Error

X0 6Y 03 FF Command buffer full

X0 6Y 04 FF Command cancelled

X0 6Y 05 FF No socket (to be cancelled)

X0 6Y 41 FF Command not executable

X =9 ~ F: BRC-300/P address + 8, Y = socket number

Socket number

When command messages are sent to the BRC-300/P, it is normal to send the next command message after waiting for the completion message or error message to return. However to deal with advanced uses, the BRC-300/P has two buffers (memories) for commands, so that up to two commands including the commands currently being executed can be received. When the BRC-300/P receives commands, it notifies the sender which command buffer was used using the socket number of the ACK message.

Command execution cancel

To cancel a command which has already been sent, send the Cancel command as the next command. To cancel one of any two commands which have been sent, use the cancel message.

Cancel Packet Note

Cancel 8X 2Y FF Y =socket number

X =1 ~ 7: BRC-300/P address, Y = socket number

The Command canceled error message will be returned for this command, but this is not a fault. It indicates that the command has been canceled.

VISCA Device Setting

Before starting control of the BRC-300/P, be sure to send the Address command and the 1F_Clear command using the broadcast function.

For VISCA network administration

Address

Sets an address of a peripheral device. Use when initializing the network, and receiving the following network change message.

Network Change

Sent from the peripheral device to the controller when a device is removed from or added to the network. The address must be re-set when this message is received.

Packet Note

Address 88 30 01 FF Always broadcasted.

Network Change X0 38 FF

X =9 ~ F : BRC-300/P address + 8

VISCA interface command

IF_Clear

Clears the command buffers in the BRC-300/P and cancels the command currently being executed.

Command Packet Reply Packet Note

IF_Clear 8X 01 00 01 FF X0 50 FF

IF_Clear (broadcast) 88 01 00 01 FF 88 01 00 01 FF

X =1 ~ 7 : BRC-300/P address (For inquiry packet)

X =9 ~ F : BRC-300/P address + 8 (For reply packet)

VISCA interface and inquiry

CAM_VersionInq

Returns information on the VISCA interface.

Inquiry	Inquiry Packet	Reply Packet	Description
CAM_VersionInq	8X 09 00 02 FF	Y0 50 GG GG HH HH JJ JJ KK FF	GGGG =Vender ID (0001:Sony) HHHH =Model ID 040F: BRC-300/P 0410: BRU-300/P JJJJ =ROM revision KK =Maximum socket #(02)
		X =1 ~ 7 : BRC-300/P address (For inquiry packet)	
		Y =9 ~ F : BRC-300/P address + 8 (For reply packet)	

VISCA Command/ACK Protocol

Command	Command Message	Reply Message	Comments
General Command	81 01 04 38 02 FF (Example)	90 41 FF (ACK)+90 51 FF (Completion) 90 42 FF 90 52 FF	Returns ACK when a command has been accepted, and Completion when a command has been executed.
	81 01 04 38 FF (Example)	90 60 02 FF (Syntax Error)	Accepted a command which is not supported or a command lacking parameters.
	81 01 04 38 02 FF (Example)	90 60 03 FF (Command Buffer Full)	There are two commands currently being executed, and the command could not be accepted.
	81 01 04 08 02 FF (Example)	90 61 41 FF (Command Not Executable) 90 62 41FF	Could not execute the command in the current mode.
Inquiry Command	81 09 04 38 FF (Example)	90 50 02 FF (Completion)	ACK is not returned for the inquiry command.
	81 09 05 38 FF (Example)	90 60 02 FF (Syntax Error)	Accepted an incompatible command.
Address Set	88 30 01 FF	88 30 02 FF	Returned the device address to + 1 (Note)
IF_Clear(Broadcast)	88 01 00 01 FF	88 01 00 01 FF	Returned the same command.
IF_Clear(For X)	8x 01 00 01 FF	z0 50 FF (Completion)	ACK is not returned for this command.
Command Cancel	8x 2y FF	z0 6y 04 FF (Command Canceled)	Returned when the command of the socket specified is canceled. Completion for the command canceled is not returned.
		z0 6y 05 FF (No Socket)	Returned when the command of the specified socket has already been completed or when the socket number specified is wrong.

Do not transmit the command (except Address Set, IF_Clear, Command Cancel, CAM_Power), when menu panel shows on the screen. In that case, clear the menu panel first, using CAMMenu Command and then proceed.

(Note) The address-switch is fixed at 0, the value x in 88 30 0x FF will be indeterminate.

VISCA Camera-Issued Messages

ACK/Completion Messages

Command	Command Message	Comments
ACK	z0 4y FF (y: Socket No.)	Returned when the command is accepted.
Completion	z0 5y FF (y: Socket No.)	Returned when the command has been executed.

z = Device address + 8

Error Messages

Command	Command Message	Comments
Syntax Error	z0 60 02 FF	Returned when the command format is different or when a command with illegal command parameters is accepted.
Command Buffer Full	z0 60 03 FF	Indicates that two sockets are already being used (executing two commands) and the command could not be accepted when received.
Command Canceled	z0 6y 04 FF (y: Socket No.)	Returned when a command which is being executed in a socket specified by the cancel command is canceled. The completion message for the command is not returned.
No Socket	z0 6y 05 FF (y: Socket No.)	Returned when no command is executed in a socket specified by the cancel command, or when an invalid socket number is specified.
Command Not Executable	z0 6y 41 FF (y: Socket No.)	Returned when a command cannot be executed due to current conditions. For example, when commands controlling the focus manually are received during auto focus.

Network Change Message

Command	Command Message	Comments
Network Change	z0 38 FF	Returned when a command cannot be executed due to current conditions. For example, when commands controlling the focus manually are received during auto focus.

BRC-300/P Commands

BRC-300/P Command List (1/4)

Command Set	Command	Command Packet	Comments
AddressSet	Broadcast	88 30 01 FF	Address Set
IF_Clear	Broadcast	88 01 00 01 FF	I/F Clear
CommandCancel		8x 2p FF	p:Socket No (=1 to 2)
CAM_Power	On	8x 01 04 00 02 FF	PowerOn/Off
	Off	8x 01 04 00 03 FF	
Cam_Zoom	Stop	8x 01 04 07 00 FF	
	Tele(Standard)	8x 01 04 07 02 FF	
	Wide(Standard)	8x 01 04 07 03 FF	
	Tele(Variable)	8x 01 04 07 2p FF	
	Wide(Variable)	8x 01 04 07 3p FF	
	Direct	8x 01 04 47 0p 0q 0r 0s FF	pqrs:Zoom Position Note 1)
CAM_Dzoom	On	8x 01 04 06 02 FF	DigitalZoom On/Off
	Off	8x 01 04 06 03 FF	
	Combine Mode	8x 01 04 36 00 FF	OPT/Digital Zoom Combine
	Separate Mode	8x 01 04 36 01 Ff	OPT/Digital Zoom Separate
	Stop	8x 01 04 06 00 FF	
	Tele(Variable)	8x 01 04 06 2p FF	p(=0:Slow to 7:Fast)
	Wide(Variable)	8x 01 04 06 3p FF	p(=0:Slow to 7:Fast)
Direct	8x 01 04 46 00 00 0p 0q FF	pq:Digital Zoom Position Note 1)	
CAM_Focus	Stop	8x 01 04 08 00 FF	
	Far(Standard)	8x 01 04 08 02 FF	
	Near(Standard)	8x 01 04 08 03 FF	
	Far(Variable)	8x 01 04 08 2p FF	p(=0:Lowto 7:High)
	Near(Variable)	8x 01 04 08 3p FF	p(=0:Lowto 7:High)
	Direct	8x 01 04 48 0p 0q 0r 0s FF	pqrs: Focus Position Note 1)
	Auto Focus	8x 01 04 38 02 FF	AF ON/OFF
	Manual Focus	8x 01 04 38 03 FF	
	Auto/Manual	8x 01 04 38 10 FF	
	One Push Trigger	8x 01 04 18 01 FF	One Push AF Trigger
Infinity	8x 01 04 18 02 FF	Forced Infinity	
CAM_AF Mode	Normal AF	8x 01 04 57 00 FF	Normal AF mode
	Interval AF	8x 01 04 57 01 FF	Inerval AF Mode
	Zoom Trigger AF	8x 01 04 57 02 FF	Zoom Trigger Mode
	Active/Interval Time	8x 01 04 27 0p 0p 0q 0q FF	pp: Active Time qq: Interval Time
CAM_ZoomFocus	Direct	8x 01 04 47 0p 0q 0r 0s 0t 0u 0v 0w FF	pqrs: Zoom Position Note 1) tuvw: Focus Position
CAM_WB	Auto	8x 01 04 35 00 FF	Normal Auto
	Indoor	8x 01 04 35 01 FF	Indoor Mode
	Outdoor	8x 01 04 35 02 FF	Outdoor Mode
	One Push WB	8x 01 04 35 03 FF	One Push WB Mode
	Manual	8x 01 04 35 05 FF	Manual Control Mode
	One Push Trigger	8x 01 04 10 05 FF	One Push WB trigger

Note 1) See the section under VISCA Command Setting Values.

BRC-300/P Command List (2/4)

Command Set	Command	Command Packet	Comments
CAM_RGain	Reset	8x 01 04 03 00 FF	R Gain setting
	Up	8x 01 04 03 02 FF	
	Down	8x 01 04 03 03 FF	
	Direct	8x 01 04 43 00 00 0p 0q FF	R Gain pq(=00 to FF)
CAM_BGain	Reset	8x 01 04 04 00 FF	B Gain setting
	Up	8x 01 04 04 02 FF	
	Down	8x 01 04 04 03 FF	
	Direct	8x 01 04 44 00 00 0p 0q FF	B Gain pq(=00 to FF)
CAM_AE	Full Auto	8x 01 04 39 00 FF	Automatic exposure mode
	Manual	8x 01 04 39 03 FF	Manual control mode
	Shutter Priority	8x 01 04 39 0A FF	Shutter priority automatic exposure mode
	Iris Priority	8x 01 04 39 0B FF	Iris priority automatic exposure mode
	Bright	8x 01 04 39 0D FF	Bright mode (Manual)
CAM_SlowShutter	Auto	8x 01 04 5A 02 FF	AutoSlowShutter On/Off
	Manual	8x 01 04 5A 03 FF	
CAM_Shutter	Reset	8x 01 04 0A 00 FF	Shutter setting (1/4sec ~ 1/10000sec)
	Up	8x 01 04 0A 02 FF	
	Down	8x 01 04 0A 03 FF	
	Direct	8x 01 04 4A 00 00 0p 0q FF	pq: Shutter Position Note 1)
CAM_Iris	Reset	8x 01 04 0B 00 FF	Iris setting
	Up	8x 01 04 0B 02 FF	
	Down	8x 01 04 0B 03 FF	
	Direct	8x 01 04 4B 00 00 0p 0q FF	pq: Iris Position Note 1)
CAM_Gain	Reset	8x 01 04 0C 00 FF	Gain setting
	Up	8x 01 04 0C 02 FF	
	Down	8x 01 04 0C 03 FF	
	Direct	8x 01 04 4C 00 00 0p 0q FF	pqrs: Gain Position Note 1)
CAM_Bright	Reset	8x 01 04 0D 00 FF	Bright setting
	Up	8x 01 04 0D 02 FF	
	Down	8x 01 04 0D 03 FF	
	Direct	8x 01 04 4D 00 00 0p 0q FF	pqrs: Bright Position Note 1)
CAM_ExpComp	On	8x 01 04 3E 02 FF	Exposure Compensation ON/OFF
	Off	8x 01 04 3E 03 FF	
	Reset	8x 01 04 0E 00 FF	Exposure Compensation amount setting
	Up	8x 01 04 0E 02 FF	
	Down	8x 01 04 0E 03 FF	
	Direct	8x 01 04 4E 00 00 0p 0q FF	pqrs: ExpComp Position Note 1)
CAM_BackLight	On	8x 01 04 33 02 FF	Back Light Compensation
	Off	8x 01 04 33 03 FF	
CAM_SpotAE	On	8x 01 04 59 02 FF	Setting for AE
	Off	8x 01 04 59 03 FF	
	Position	8x 01 04 29 0p 0q 0r 0s FF	pq: x(=00-0F) rs: y(=00-0F)

Note 1) See the section under VISCA Command Setting Values.

BRC-300/P Command List (3/4)

Command Set	Command	Command Packet	Comments
CAM_Aperture	Reset	8x 01 04 02 00 FF	Aperture Control
	Up	8x 01 04 02 02 FF	
	Down	8x 01 04 02 03 FF	
	Direct	8x 01 04 42 00 00 00 0q FF	Aperture Gain q(=0 to F)
CAM_PictureEffect	Off	8x 01 04 63 00 FF	Picture Effect setting
	Neg.Art	8x 01 04 63 02 FF	
	B&W	8x 01 04 63 04 FF	
CAM_Wide	Off	8x 01 04 60 00 FF	Wide mode setting
	Wide 16:9	8x 01 04 60 02 FF	
CAM_Memory	Reset	8x 01 04 3F 00 0p FF	Memory number p(=0 to 5)
	Set	8x 01 04 3F 01 0p FF	Memory number p(=0 to 5)
	Recall	8x 01 04 3F 02 0p FF	Memory number p(=0 to 5)
CAM_Menu	Off	8x 01 06 06 03 FF	
CAM_Title	Title Set 1	8x 01 7E 01 10 uu vv ww 00 00 00 00 00 00 00 FF	Hposition uu(=00 to 18h) Vposition:NTSC vv(=00 to 09) :PAL vv(=00 to 0A) Blink ww(1:On 0:Off)
	Title Set 2	8x 01 7E 01 11 aa bb cc dd ee ff gg hh ii jj FF	First 10 Words (ASCII CODE 0x20-0x7E)
	Title Set 3	8x 01 7E 01 12 kk ll mm nn oo pp qq rr ss tt FF	Second 10 Words (ASCII CODE 0x20-0x7E)
	Title Clear	8x 01 7E 01 13 00 FF	
	Title On	8x 01 7E 01 13 02 FF	
	Title Off	8x 01 7E 01 13 03 FF	
CAM_Preset_title	Title Set 1	8x 01 7E 01 14 uu vv ww 0! 00 00 00 00 00 00 FF	Hposition uu(=00 to 18h) Vposition:NTSC vv(=00 to 09) :PAL vv(=00 to 0A) Blink ww(1:On 0:Off) presetNo !(= 0to5)
	Title Set 2	8x 01 7E 01 15 0! aa bb cc dd ee ff gg hh ii jj FF	aa-jj:First 10 Words (ASCII CODE 0x20-0x7E) position No !(=0 to 5)
	Title Set 3	8x 01 7E 01 16 0! kk ll mm nn oo pp qq rr ss tt FF	kk-tt:Second 10 Words (ASCII CODE 0x20-0x7E) position No !(=0 to 5)
	Title Clear	8x 01 7E 01 17 0! 00 FF	position No !(=0 to 5 or F: ALL CLEAR)
	Title On	8x 01 7E 01 17 00 02 FF	
	Title Off	8x 01 7E 01 17 00 03 FF	
CAM_IDWrite		8x 01 04 22 0p 0q 0r 0s FF	CameraID pqrs(=0000 to FFFF)
IR_Receive	On	8x 01 06 08 02 FF	IR-Remote Control Signal Receive On/Off
	Off	8x 01 06 08 03 FF	
	On/Off	8x 01 06 08 10 FF	

Note 1) See the section under VISCA Command Setting Values.

BRC-300/P Command List (4/4)

Command Set	Command	Command Packet	Comments
Pan-tiltDrive	Up	8x 01 06 01 VV WW 03 01 FF	PanSpeed VV(=01:Slow to18h:Fast) TiltSpeed WW(=01:Slow to18h:Fast)
	Down	8x 01 06 01 VV WW 03 02 FF	
	Left	8x 01 06 01 VV WW 01 03 FF	
	Right	8x 01 06 01 VV WW 02 03 FF	
	UpLeft	8x 01 06 01 VV WW 01 01 FF	
	UpRight	8x 01 06 01 VV WW 02 01 FF	
	DownLeft	8x 01 06 01 VV WW 01 02 FF	
	DownRight	8x 01 06 01 VV WW 02 02 FF	
	Stop	8x 01 06 01 VV WW 03 03 FF	
	AbsolutePosition	8x 01 06 02 VV WW 0Y 0Y 0Y 0Y 0Y 0Z 0Z 0Z 0Z FF	VV WW as identified above Note1)
	RelativePosition	8x 01 06 03 VV WW 0Y 0Y 0Y 0Y 0Y 0Z 0Z 0Z 0Z FF	VV WW as identified above Note1)
	Home	8x 01 06 04 FF	
	Reset	8x 01 06 05 FF	
Pan-tiltLimitSet	Limit Set	8x 01 06 07 00 0W 0Y 0Y 0Y 0Y 0Y 0Z 0Z 0Z 0Z FF	W:1UpRight 0:DownLeft 注1) YYYYY:PanLimit Position 0x0000(Center) 0x08A58(Left End) 0xF75A8(Right End) ZZZZ:TiltLimit Position 0x0000(Center) 0x493D(Up End) 0xE796(Down End)
	Limit Clear	8x 01 06 07 01 0W 07 0F 0F 0F 0F 07 0F 0F 0F FF	W:1UpRight 0:DownLeft
Analog-Card setup	Output 1 RGB	8x 01 7E 01 03 0p 00 FF	p: 0 BRC-300 Slot/BRU-300 Slot1 1 BRU-300 Slot2
	Output 1 YCbCr	8x 01 7E 01 03 0p 01 FF	
	RGB SYNC OFF	8x 01 7E 01 07 0p 00 FF	
	RGB SYNC G	8x 01 7E 01 07 0p 01 FF	
	RGB SYNC RGB	8x 01 7E 01 07 0p 02 FF	
	Output 2 VBS	8x 01 7E 01 04 0p 00 FF	
	Output 2 Y/C	8x 01 7E 01 04 0p 01FF	
CAM_ImgFlip	On	8x 01 04 66 02 FF	
	Off	8x 01 04 66 03 FF	
CAM_DataMix	On	8x 01 7E 01 05 00 02 FF	
	Off	8x 01 7E 01 05 00 03 FF	
CAM_PanReverse	On	8x 01 7E 01 06 00 01 FF	
	Off	8x 01 7E 01 06 00 00 FF	
Cam_TiltReverse	On	8x 01 7E 01 09 00 01 FF	
	Off	8x 01 7E 01 09 00 00 FF	
Cmd_Tally	On	8x 01 7E 01 0A 00 02 FF	When Power is on, return to off.
	Off	8x 01 7E 01 0A 00 03 FF	
Cmd_PT_M_Speed	Preset PT Speed	8x 01 7E 01 0B 0p 0q FF	p: Memory number (=0 to 5) q: Speed (=1 to 24:fast)
Cmd_Disp_Info	On	8x 01 7E 01 18 02 FF	
	Off	8x 01 7E 01 18 03 FF	
Cmd_dzm_chg	E-Zoom Limit	81 01 7E 01 19 0p FF	p: 0 D-Zoom Limit x2 1 D-Zoom Limit x4

Note 1) See the section under VISCA Command Setting Values.

BRC-300/P Inquiry Command List (1/2)

Inquiry Command	Command Packet	Inquiry Packet	Comments
CAM_PowerInq	8x 09 04 00 FF	y0 50 02 FF	On
		y0 50 03 FF	Off(Standby)
CAM_ZoomPosInq	8x 09 04 47 FF	y0 50 0p 0q 0r 0s FF	pqr: Zoom Position
CAM_DZoomModelInq	8x 09 04 06 FF	y0 50 02 FF	D-Zoom On
		y0 50 03 FF	D-Zoom Off
CAM_DZoomC/SModelInq	8x 09 04 36 FF	y0 50 00 FF	Combine Mode
		y0 50 01 FF	Separate Mode
CAM_DZoomPosInq	8x 09 04 46 FF	y0 50 00 0 0p 0q FF	pq: Digital Zoom Position
CAM_FocusModelInq	8x 09 04 38 FF	y0 50 02 FF	Auto Focus
		y0 50 03 FF	Manual Focus
CAM_FocusPosInq	8x 09 04 48 FF	y0 50 0p 0q 0r 0s FF	pqr: Focus Position
CAM_AFModelInq	8x 09 04 57 FF	y0 50 00 FF	Normal AF
		y0 50 01 FF	Interval AF
		y0 50 02 FF	Zoom Trigger AF
CAM_AFTimeSettingInq	8x 09 04 27 FF	y0 50 0p 0q 0r 0s FF	pq: Active Time rs:Interval Time
CAM_WBModelInq	8x 09 04 35 FF	y0 50 00 FF	Auto
		y0 50 01 FF	Indoor
		y0 50 02 FF	Outdoor
		y0 50 03 FF	One Push WB
		y0 50 05 FF	Manual
CAM_RGainInq	8x 09 04 43 FF	y0 50 00 00 0p 0q FF	pq: R Gain
CAM_BGainInq	8x 09 04 44 FF	y0 50 00 00 0p 0q FF	pq: B Gain
CAM_AEModelInq	8x 09 04 39 FF	y0 50 00 FF	Full Auto
		y0 50 03 FF	Manual
		y0 50 0A FF	Shutter Priority
		y0 50 0B FF	Iris Priority
		y0 50 0D FF	Bright
CAM_SlowShutterModelInq	8x 09 04 5A FF	y0 50 02 FF	Auto
		y0 50 03 FF	Manual
CAM_ShutterPosInq	8x 09 04 4A FF	y0 50 00 00 0p 0q FF	pq: Shutter Position
CAM_IrisPosInq	8x 09 04 4B FF	y0 50 00 00 0p 0q FF	pq: Iris Position
CAM_GainPosInq	8x 09 04 4C FF	y0 50 00 00 0p 0q FF	pq: Gain Position
CAM_BrightPosInq	8x 09 04 4D FF	y0 50 00 00 0p 0q FF	pq: Bright Position
CAM_ExpCompModelInq	8x 09 04 3E FF	y0 50 02 FF	On
		y0 50 03 FF	Off
CAM_ExpCompPosInq	8x 09 04 4E FF	y0 50 00 00 0p 0q FF	pq: ExpComp Position
CAM_BackLightModelInq	8x 09 04 33 FF	y0 50 02 FF	On
		y0 50 03 FF	Off
CAM_SpotAEModelInq	8x 09 04 59 FF	y0 50 02 FF	On
		y0 50 03 FF	Off
CAM_SpotAEPosInq	8x 09 04 29 FF	y0 50 0p 0q 0r 0s FF	pq: X position, rs: Y position
CAM_ApertureInq	8x 09 04 42 FF	y0 50 00 00 0p 0q FF	pq: Aperture Gain
CAM_WideModelInq	8x 09 04 60 FF	y0 50 00 FF	Off
		y0 50 02 FF	16:9 Wide

BRC-300/P Inquiry Command List (2/2)

Inquiry Command	Command Packet	Inquiry Packet	Comments
CAM_PictureEffectModelInq	8x 09 04 63 FF	y0 50 00 FF	Off
		y0 50 02 FF	Neg.Art
		y0 50 04 FF	B & W
CAM_MemoryInq	8x 09 04 3F FF	y0 50 pp FF	pp: Memory number last operated
CAM_MENUInq	8x 09 06 06 FF	y0 50 02 FF	On
		y0 50 03 FF	Off
CAM_IDInq	8x 09 04 22 FF	y0 50 0p 0q 0r 0s FF	pqrs: Camera ID
CAM_VersionInq	8x 09 00 02 FF	y0 50 00 20 mn pq rs tu vw FF	mnpq: Model Code(04XX) rstu: ROM version vw: Socket Number(02)
CAM_TitleModelInq	8x 09 7E 01 13 FF	y0 50 02 FF	On
		y0 50 03 FF	Off
CAM_PresetTitleModelInq	8x 09 7E 01 17 FF	y0 50 02 FF	On
		y0 50 03 FF	Off
IR_ReceiveInq	8x 09 06 08 FF	y0 50 02 FF	On
		y0 50 03 FF	Off
Analog_Card Output1Inq	8x 09 7E 01 03 FF	y0 50 0p FF	p=0 RGB 1:YCbCr
Analog_Card Output2Inq	8x 09 7E 01 04 FF	y0 50 0p FF	p=0 VBS 1:Y/C
Analog_Card RGB_SYNCInq	8x 09 7E 01 07 FF	y0 50 0p FF	p=0 OFF 1:G 2:RGB
CAM_ImgFlipInq	8x 09 04 66 FF	y0 50 02 FF	On
		y0 50 03 FF	Off
CAM_DataMixInq	8x 09 7E 01 05 FF	y0 50 02 FF	On
		y0 50 03 FF	Off
CAM_PanReverseInq	8x 09 7E 01 06 FF	y0 50 01 FF	On
		y0 50 00 FF	Off
CAM_TiltReverseInq	8x 09 7E 01 09 FF	y0 50 01 FF	On
		y0 50 00 FF	Off
PanTilt_Status	8x 09 06 10 FF	y0 50 pq rs FF	pqrs: PanTilt Status
PanTilt_Max_Speed	8x 09 06 11 FF	y0 50 pq rs FF	pq: Pan Max Speed rs: Tilt Max Speed
PanTilt_Position	8x 09 06 12 FF	y0 50 0p 0q 0r 0s 0t 0u 0v 0w 0x FF	pqrst: Pan Position uvwxy: Tilt Position
Tally	8x 09 7E 01 0A FF	y0 50 02 FF	On
		y0 50 03 FF	Off
PanTilt_Memory_Speed	8x 09 7E 01 0B 0p FF	y0 50 0q FF	p: Preset No. 0 ~ 5 q: Speed 1 ~ 24

BRC-300/P Block Inquiry Command List

Lens control system inquiry Command Packet 8x 09 7E 7E 00 FF

Byte	Bit	Comments
0	7	Destination Address
	6	
	5	
	4	
	3	Source Address
	2	
	1	
	0	
1	7	0 Completion Message(50h)
	6	1
	5	0
	4	1
	3	0
	2	0
	1	0
	0	0
2	7	0
	6	0
	5	0
	4	0
	3	Zoom Position (HH)
	2	
	1	
	0	
3	7	0
	6	0
	5	0
	4	0
	3	Zoom Position (HL)
	2	
	1	
	0	
4	7	0
	6	0
	5	0
	4	0
	3	Zoom Position (LH)
	2	
	1	
	0	
5	7	0
	6	0
	5	0
	4	0
	3	Zoom Position (LL)
	2	
	1	
	0	

Byte	Bit	Comments
6	7	0
	6	0
	5	0
	4	0
	3	0
	2	0
	1	0
	0	0
7	7	0
	6	0
	5	0
	4	0
	3	0
	2	0
	1	0
	0	0
8	7	0
	6	0
	5	0
	4	0
	3	Focus Position (HH)
	2	
	1	
	0	
9	7	0
	6	0
	5	0
	4	0
	3	Focus Position (HL)
	2	
	1	
	0	
10	7	0
	6	0
	5	0
	4	0
	3	Focus Position (LH)
	2	
	1	
	0	
11	7	0
	6	0
	5	0
	4	0
	3	Focus Position (LL)
	2	
	1	
	0	

Byte	Bit	Comments
12	7	0
	6	0
	5	0
	4	0
	3	0
	2	0
	1	0
	0	0
13	7	0
	6	0
	5	DZoomMode 1: Separate 0: Combine
	4	AF Mode
	3	0:Normal 1:Interval 2:Zoom Trigger
	2	0
	1	Digital Zoom 1:On 0:Off
	0	Focus Mode 1:Auto 0:Manual
14	7	0
	6	0
	5	0
	4	0
	3	0
	2	Camera Memory Recall 1: Executing 0: Stopped
	1	Focus Command 1: Executing 0: Stopped
	0	Zoom Command 1: Executing 0: Stopped
15	7	1 Terminator (FFh)
	6	1
	5	1
	4	1
	3	1
	2	1
	1	1
	0	1

Camera control system inquiry comands..... Command Packet 8x 09 7E 7E 01 FF

Byte	Bit	Comments
0	7	Destination Address
	6	
	5	
	4	
	3	Source Address
	2	
	1	
	0	
1	7	0 Completion Message(50h)
	6	1
	5	0
	4	1
	3	0
	2	0
	1	0
	0	0
2	7	0
	6	0
	5	0
	4	0
	3	R Gain (H)
	2	
	1	
	0	
3	7	0
	6	0
	5	0
	4	0
	3	R Gain (L)
	2	
	1	
	0	
4	7	0
	6	0
	5	0
	4	0
	3	B Gain (H)
	2	
	1	
	0	
5	7	0
	6	0
	5	0
	4	0
	3	B Gain (L)
	2	
	1	
	0	

Byte	Bit	Comments
6	7	0
	6	0
	5	0
	4	0
	3	0
	2	WB Mode
	1	
	0	
7	7	
	6	0
	5	0
	4	0
	3	Aperture Gain
	2	
	1	
	0	
8	7	0
	6	0
	5	0
	4	Exposure Mode
	3	
	2	
	1	
	9	7
6		0
5		0
4		0
3		Exposure Mode
2		Back Light 1:On 0:Off
1		Exposure Comp. 1:On 0:Off
0		Slow Shutter 1:Auto 0:Manual
10	7	0
	6	0
	5	0
	4	Shutter Position
	3	
	2	
	1	
	11	7
6		0
5		0
4		Iris Position
3		
2		
1		
0		0

Byte	Bit	Comments
12	7	0
	6	0
	5	0
	4	0
	3	Gain Position
	2	
	1	
	0	
13	7	0
	6	0
	5	0
	4	Bright Position
	3	
	2	
	1	
	14	7
6		0
5		0
4		0
3		Exposure Comp. Position
2		
1		
0		
15	7	1 Terminator (FFh)
	6	1
	5	1
	4	1
	3	1
	2	1
	1	1
	0	1

Other inquiry commands..... Command Packet 8x 09 7E 7E 02 FF

Byte	Bit	Comments
0	7	Destination Address
	6	
	5	
	4	
	3	Source Address
	2	
	1	
	0	
1	7	0 Completion Message(50h)
	6	1
	5	0
	4	1
	3	0
	2	0
	1	0
	0	0
2	7	0
	6	0
	5	0
	4	0
	3	0
	2	0
	1	0
	0	Power 1:On 0:Off
3	7	0
	6	0
	5	0
	4	0
	3	0
	2	0
	1	Wide Mode 1:Wide, 0:Off
	0	0
4	7	0
	6	0
	5	0
	4	0
	3	0
	2	0
	1	0
	0	0
5	7	0
	6	0
	5	0
	4	0
	3	Picture Effect Mode
	2	
	1	
	0	

Byte	Bit	Comments
6	7	0
	6	0
	5	0
	4	0
	3	0
	2	0
	1	0
	0	0
7	7	0
	6	0
	5	0
	4	0
	3	0
	2	0
	1	0
	0	0
8	7	0
	6	0
	5	0
	4	0
	3	Camera ID (HH)
	2	
	1	
	0	
9	7	0
	6	0
	5	0
	4	0
	3	Camera ID (HL)
	2	
	1	
	0	
10	7	0
	6	0
	5	0
	4	0
	3	Camera ID (LH)
	2	
	1	
	0	
11	7	0
	6	0
	5	0
	4	0
	3	Camera ID (LL)
	2	
	1	
	0	

Byte	Bit	Comments
12	7	0
	6	0
	5	0
	4	Memory 1:Yes 0:No
	3	0
	2	0
	1	0
	0	System 1:PAL 0:NTSC
13	7	0
	6	0
	5	0
	4	0
	3	0
	2	0
	1	0
	0	0
14	7	0
	6	0
	5	0
	4	0
	3	0
	2	0
	1	0
	0	0
15	7	1 Terminator (FFh)
	6	1
	5	1
	4	1
	3	1
	2	1
	1	1
	0	1

Enlargement Function Query Command..... Command Packet 8x 09 7E 7E 03 FF

Byte	Bit	Comments
0	7	Destination Address
	6	
	5	
	4	
	3	Source Address
	2	
	1	
	0	
1	7	0 Completion Message(50h)
	6	1
	5	0
	4	1
	3	0
	2	0
	1	0
	0	0
2	7	0
	6	0
	5	0
	4	0
	3	Digital Zoom Position (H)
	2	
	1	
	0	
3	7	0
	6	0
	5	0
	4	0
	3	Digital Zoom Position (L)
	2	
	1	
	0	
4	7	0
	6	0
	5	0
	4	0
	3	AF Activation Time(H)
	2	
	1	
	0	
5	7	0
	6	0
	5	0
	4	0
	3	AF Activation Time(L)
	2	
	1	
	0	

Byte	Bit	Comments
6	7	0
	6	0
	5	0
	4	0
	3	AF Interval Time (H)
	2	
	1	
	0	
7	7	0
	6	0
	5	0
	4	0
	3	AF Interval Time (L)
	2	
	1	
	0	
8	7	0
	6	0
	5	0
	4	0
	3	SpotAE Position (X)
	2	
	1	
	0	
9	7	0
	6	0
	5	0
	4	0
	3	SpotAE Position (Y)
	2	
	1	
	0	
10	7	0
	6	0
	5	0
	4	0
	3	0
	2	0
	1	0
	0	0
11	7	0
	6	0
	5	0
	4	0
	3	0
	2	0
	1	0
	0	0

Byte	Bit	Comments
12	7	0
	6	0
	5	0
	4	0
	3	0
	2	0
	1	0
	0	0
13	7	0
	6	0
	5	0
	4	0
	3	0
	2	0
	1	0
	0	0
14	7	0
	6	0
	5	0
	4	0
	3	0
	2	0
	1	0
	0	0
15	7	1 Terminator (FFh)
	6	1
	5	1
	4	1
	3	1
	2	1
	1	1
	0	1

VISCA Command Setting Values

Exposure Control (1/2)

IRIS

DATA	IRIS (F1.6)
	F No.
11	F1.6
10	F2.0
0F	F2.4
0E	F2.8
0D	F3.4
0C	F4
0B	F4.8
0A	F5.6
09	F6.8
08	F8
07	F9.6
06	F11
05	F14
04	F16
03	F19
02	F22
01	F28
00	CLOSE

IRIS



ND



IRIS

Shutter Speed

DATA	NTSC	PAL
	[sec]	[sec]
15	1/10000	1/10000
14	1/6000	1/6000
13	1/4000	1/3500
12	1/3000	1/2500
11	1/2000	1/1750
10	1/1500	1/1250
0F	1/1000	1/1000
0E	1/725	1/600
0D	1/500	1/425
0C	1/350	1/300
0B	1/250	1/215
0A	1/180	1/150
09	1/125	1/120
08	1/100	1/100
07	1/90	1/75
06	1/60	1/50
05	1/30	1/25
04	1/15	1/12
03	1/8	1/6
02	1/4	1/3

GAIN

DATA	GAIN
7	18dB
6	15dB
5	12dB
4	9dB
3	6dB
2	3dB
1	0
0	-3dB

Exposure Control (2/2)

Bright

DATA	AGC	IRIS (F1.6)
	GAIN	F No.
17	18dB	F1.6
16	15dB	F1.6
15	12dB	F1.6
14	9dB	F1.6
13	6dB	F1.6
12	3dB	F1.6
11	0	F1.6
10	0	F2.0
0F	0	F2.4
0E	0	F2.8
0D	0	F3.4
0C	0	F4
0B	0	F4.8
0A	0	F5.6
09	0	F6.8
08	0	F8
07	0	F9.6
06	0	F11
05	0	F14
04	0	F16
03	0	F19
02	0	F22
01	0	F28
00	0	CLOSE

Exposure
Adjustment

DATA	Comp Value	Display
0E	+10.5dB	+7
0D	+9dB	+6
0C	+7.5dB	+5
0B	+6dB	+4
0A	+4.5dB	+3
09	+3dB	+2
08	+1.5dB	+1
07	0dB	0
06	-1.5dB	-1
05	-3dB	-2
04	-4.5dB	-3
03	-6dB	-4
02	-7.5dB	-5
01	-9dB	-6
00	-10.5dB	-7

Zoom Ratio and Zoom Position
(for reference)

Optical Zoom

Position DATA	Zoom Ratio x 12 Lens
0000	x 1
1982	x 2
24E2	x 3
2BC9	x 4
3099	x 5
343D	x 6
3724	x 7
3988	x 8
3B8B	x 9
3D43	x 10
3EBB	x 11
4000	x 12

Focus Ratio and Focus Position
(for reference)

Optical Zoom

Focus Ratio	Focus Distance
1000	Over Inf
2000	5m
3000	2m
4000	1.2m
5000	80cm
6000	50cm
7000	20cm
8000	11cm
9000	6cm
A000	3.5cm
B000	2cm
C000	1cm

Digital Zoom

Position DATA	Zoom Ratio x 12 Lens
4000	x 1
6A00	x 2
7800	x 3
7F00	x 4

Pan/Tilt position (for reference)

Pan

Angle Degree)	Left	Right
	YYYYY	YYYYY
0	00000	00000
10	00823	FF7DD
20	01046	FEFBA
30	01869	FE797
40	0208C	FD74
50	028AF	FD751
60	030D2	FCF2E
70	038F5	FC70B
80	04118	FBEE8
90	0493B	FB6C5
100	0515E	FAEA2
110	05981	FA67F
120	061A4	F9E5C
130	069C7	F9639
140	071EA	F8E16
150	07A0D	F85F3
160	08230	F7DD0
170	08A58	F75A8

Tilt

Angle Degree)	Up	Down
	ZZZZ	ZZZZ
0	0000	0000
10	0823	F7DD
20	1046	EFBA
30	1869	E796
40	208C	
50	28AF	
60	30D2	
70	38F5	
80	4118	
90	493D	

1degree: est. 0xD0

Pan/Tilt Status Code List

P	Q	R	S	
0 - - -	- - - -	0 - - -	- - - 1	Pan direction turns to left side
0 - - -	- - - -	0 - - -	- - 1 -	Pan direction turns to right side
0 - - -	- - - -	0 - - -	- 1 - -	Tilt direction turns to upper side
0 - - -	- - - -	0 - - -	1 - - -	Tilt direction turns to lower side
0 - - -	- - - -	- - 0 0	- - - -	Pan direction operates normal
0 - - -	- - - -	- - 1 0	- - - -	Pan mechanism operates defective
0 - - -	- - 0 0	0 - - -	- - - -	Tilt direction operates normal
0 - - -	- - 1 0	0 - - -	- - - -	Tilt mechanism operates defective
0 - - -	0 1 - -	0 - - -	- - - -	Pan/Tilt operating
0 - - -	1 0 - -	0 - - -	- - - -	Pan/Tilt complete operation
0 - 0 0	- - - -	0 - - -	- - - -	Not initializing
0 - 0 1	- - - -	0 - - -	- - - -	Initializing
0 - 1 0	- - - -	0 - - -	- - - -	Complete initializing

(- :Optional)