

SONY®

DIGITAL CAMCORDER

DNW-7/7P

DNW-9WS/9WSP

DNW-90/90P

DNW-90WS/90WSP

BETACAM SX

Power HAD

MAINTENANCE MANUAL Part 1

1st Edition (Revised 3)

Serial No. 10001 and Higher
(DNW-7/9WS/90/90WS)

Serial No. 40001 and Higher
(DNW-7P/9WSP/90P/90WSP)

⚠ 警告

このマニュアルは、サービス専用です。

お客様が、このマニュアルに記載された設置や保守、点検、修理など行うと感電や火災、人身事故につながる可能性があります。

危険をさけるため、サービストレーニングを受けた技術者のみご使用ください。

⚠ WARNING

This manual is intended for qualified service personnel only.

To reduce the risk of electric shock, fire or injury, do not perform any servicing other than that contained in the operating instructions unless you are qualified to do so. Refer all servicing to qualified service personnel.

⚠ WARNUNG

Die Anleitung ist nur für qualifiziertes Fachpersonal bestimmt.

Alle Wartungsarbeiten dürfen nur von qualifiziertem Fachpersonal ausgeführt werden. Um die Gefahr eines elektrischen Schlages, Feuergefahr und Verletzungen zu vermeiden, sind bei Wartungsarbeiten strikt die Angaben in der Anleitung zu befolgen. Andere als die angegebenen Wartungsarbeiten dürfen nur von Personen ausgeführt werden, die eine spezielle Befähigung dazu besitzen.

⚠ AVERTISSEMENT

Ce manuel est destiné uniquement aux personnes compétentes en charge de l'entretien. Afin de réduire les risques de décharge électrique, d'incendie ou de blessure n'effectuer que les réparations indiquées dans le mode d'emploi à moins d'être qualifié pour en effectuer d'autres. Pour toute réparation faire appel à une personne compétente uniquement.

Voor de klanten in Nederland

Dit apparaat bevat een MnO₂-Li batterij voor memory back-up.

Raadpleeg uw leverancier over de verwijdering van de batterij op het moment dat u het apparaat bij einde levensduur afdankt.

Gooi de batterij niet weg, maar lever hem in als KCA.

X-RAY RADIATION WARNING

Be sure that parts replacement in the high voltage block and adjustments made to the high voltage circuits are carried out precisely in accordance with the procedures given in this manual.

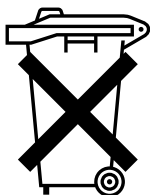

Bij dit produkt zijn batterijen geleverd. Wanneer deze leeg zijn, moet u ze niet weggooien maar inleveren als KCA.

Table of Contents

Manual Structure

Purpose of this manual	5
Contents	5
Relative manual	6

1. Service Overview

1-1. Operating Conditions	1-1
1-2. Supplied Accessories	1-1
1-3. Location of Main Parts and Function of Printed Circuit Boards	1-2
1-3-1. Location and Function of Printed Circuit Boards	1-2
1-3-2. Location of Main Parts	1-4
1-3-3. Location and Function of Sensors	1-6
1-4. Matching Connectors	1-8
1-5. Signal Input and Output	1-9
1-6. Removal/Installation of Cabinet	1-12
1-7. Removal/Installation of Cassette Compartment	1-14
1-8. Pulling Out and Inserting the Plug-in Boards	1-15
1-9. Switch/Slit Land Settings on the Boards	1-16
1-9-1. AXM-14 Board	1-16
1-9-2. CNB-1 Board	1-17
1-9-3. DVP-1 Board	1-18
1-9-4. DVP-2 Board	1-19
1-9-5. TC-80 Board	1-20
1-9-6. MDC-5 Board	1-22
1-9-7. DCP-1 Board	1-23
1-9-8. TG-164 Board (for DNW-9WS/9WSP/90/90P/90WS/ 90WSP only)	1-24
1-10. Ejecting the Cassette Tape Manually	1-25
1-11. Inserting the Cassette Tape when the Outside Panel is Removed	1-26
1-12. Cleaning when the Heads are Clogged	1-26
1-12-1. Cleaning by Cleaning Tape	1-26
1-12-2. Cleaning by Cleaning Cloth	1-27
1-13. Backup Battery	1-28
1-14. Removal/Installation of Flexible Card Wires	1-28
1-15. Fixtures	1-29
1-15-1. Extension Boards	1-29
1-15-2. Fixtures	1-30

2. Error Code

2-1.	Error Code	2-1
2-1-1.	Warning Indicators	2-1
2-1-2.	Error Codes	2-1
2-2.	Error Messages	2-2

3. Maintenance Mode

3-1.	Setup Menu	3-1
3-2.	DIAG Menu	3-24

4. Block Diagram and Circuit Description

5. Electrical Alignment

5-1.	General Information for Electrical Adjustment	5-1
5-1-1.	Note for Adjustment	5-1
5-1-2.	Equipment/Fixtures	5-1
5-1-3.	Initial Setting for Switches	5-1
5-2.	ENC Level Adjustment	5-2
5-3.	TEST OUT Adjustment	5-2
5-4.	VA Gain Adjustment	5-3
5-5.	White Shading Adjustment	5-4
5-6.	Gamma Correction Adjustment	5-5
5-7.	Black Set Adjustment	5-6
5-8.	Flare Adjustment	5-6
5-9.	Manual Knee and White Clip Adjustments	5-7
5-10.	Crispening Adjustment	5-8
5-11.	Level Dependent Adjustment	5-8
5-12.	H/V Ratio Adjustment	5-9
5-13.	Detail Level Adjustment	5-9
5-14.	Skin Tone Adjustment	5-10
5-15.	Zebra Adjustment	5-11
5-16.	Automatic Iris Adjustment	5-12

6. Electrical Alignment (Only for DNW-9WS/9WSP/90WS/90WSP)

6-1.	General Information for Electrical Adjustment	6-1
6-1-1.	Note for Adjustment	6-1
6-1-2.	Equipment/Fixtures	6-1
6-1-3.	Initial Setting for Switches	6-2
6-2.	ENC Level Adjustment	6-3
6-3.	TEST OUT Level Adjustment	6-3
6-4.	VA Gain Adjustment	6-4
6-5.	White Shading Adjustment	6-5
6-6.	Gamma Correction Adjustment	6-6
6-7.	Black Set Adjustment	6-7
6-8.	Flare Adjustment	6-7
6-9.	Manual Knee and White Clip Adjustments	6-8
6-10.	Crispening Adjustment (16:9)	6-9
6-11.	Level Dependent Adjustment (16:9)	6-9
6-12.	H/V Ratio Adjustment (16:9)	6-10
6-13.	Detail Level Adjustment (16:9)	6-10
6-14.	Crispening Adjustment (4:3)	6-11
6-15.	Level Dependent Adjustment (4:3)	6-11
6-16.	H/V Ratio Adjustment (4:3)	6-12
6-17.	Detail Level Adjustment (4:3)	6-12
6-18.	Skin Tone Adjustment	6-13
6-19.	Zebra Adjustment	6-14
6-20.	Automatic Iris Adjustment	6-15

7. Periodic Maintenance and Inspection

7-1.	Cleaning	7-1
7-1-1.	General Information for Cleaning	7-1
7-1-2.	Cleaning of Tape Running Surface of Upper Drum and Video Heads	7-3
7-1-3.	Cleaning of Tape Running Surface of Lower Drum and Lead Surface	7-4
7-1-4.	Stationary Heads Cleaning	7-5
7-1-5.	Cleaning of Tape Running System and Tape Cleaner	7-6
7-2.	Periodic Check	7-7
7-2-1.	Hours Meter	7-7
7-2-2.	Periodic Check List	7-8
7-3.	Cares After Using at Special Environment	7-9

Manual Structure

Purpose of this manual

This manual is maintenance manual of Digital Camcorder DNW-7/7P/9WS/9WSP/90/90P/90WS/90WSP.

This manual describes the maintenance information of this unit, and the information on primary services such as the error message and cleaning procedures.

Contents

The following is a summary of the sections for understanding the contents of this manual.

Section 1 Service Overview

Explains the locations of main part, the functions of printed circuit board, the removal and installation of cabinet, and the measures against trouble.

Section 2 Error Code

Explains the error messages.

Section 3 Maintenance Mode

Explains the SETUP menu (ENG mode) and DIAG menu of this unit.

Section 4 Block Diagram and Outline of Circuit

Describes the overall block diagram and the circuit descriptions.

Section 5 Electrical Alignment

Explains the general information for electrical adjustments and the electrical adjustments of camera system.

Section 6 Electrical Alignment (Only for DNW-90WS/90WSP)

Explains the general information for electrical adjustments and the electrical adjustments of camera system.

Section 7 Periodic Maintenance and Inspection

Explains the cleaning procedures and periodic checks.

Relative manual

Besides this “Maintenance Manual Part 1”, the following manuals are available for this unit.

- **Operation Manual (Supplied with this unit.)**

This manual is necessary for application and operation of this unit.

- **Maintenance Manual Part 2 (Not supplied with this unit.)**

This manual describes the information items (adjustments, board layouts, schematic diagrams, detailed parts list, etc.) that premise the service based on parts. If this manual is required, please contact Sony’s service organization.

- **BVF-V10/V10CE or BVF-V20W/V20WCE**

- **Maintenance Manual (Not supplied with this unit.)**

This manual describes the service information of the viewfinder.

If this manual is required, please contact Sony's service organization.

Section 1

Service Overview

1-1. Operating Conditions

Operating temperature : 0 to 40 °C

Humidity : 25 to 85 % (Relative humidity)

Storage temperature : -20 to 60 °C

Use under special environment (Measure for cold area)

The unit is guaranteed its operation under the temperature of 0 to 40 °C. When the unit is used under 0 °C, cover-cloth against the cold is recommended to use.

1-2. Supplied Accessories

Description	Part No.	Quantity
Shoulder belt	A-6772-374-B	1
Microphone	1-542-295-11	1
XLR cap (2)	3-741-726-03	2
XLR cap (1)	3-741-727-03	2
Screw P2.6 × 5	7-627-556-58	3
Operation manual	—	1 ^{*1}
	—	3 ^{*2}
Maintenance manual Part 1	—	1

*1: For DNW-7/90/90WS

*2: For DNW-7P/90P/90WSP

1-3. Location of Main Parts and Function of Printed Circuit Boards

1-3-1. Location and Function of Printed Circuit Boards

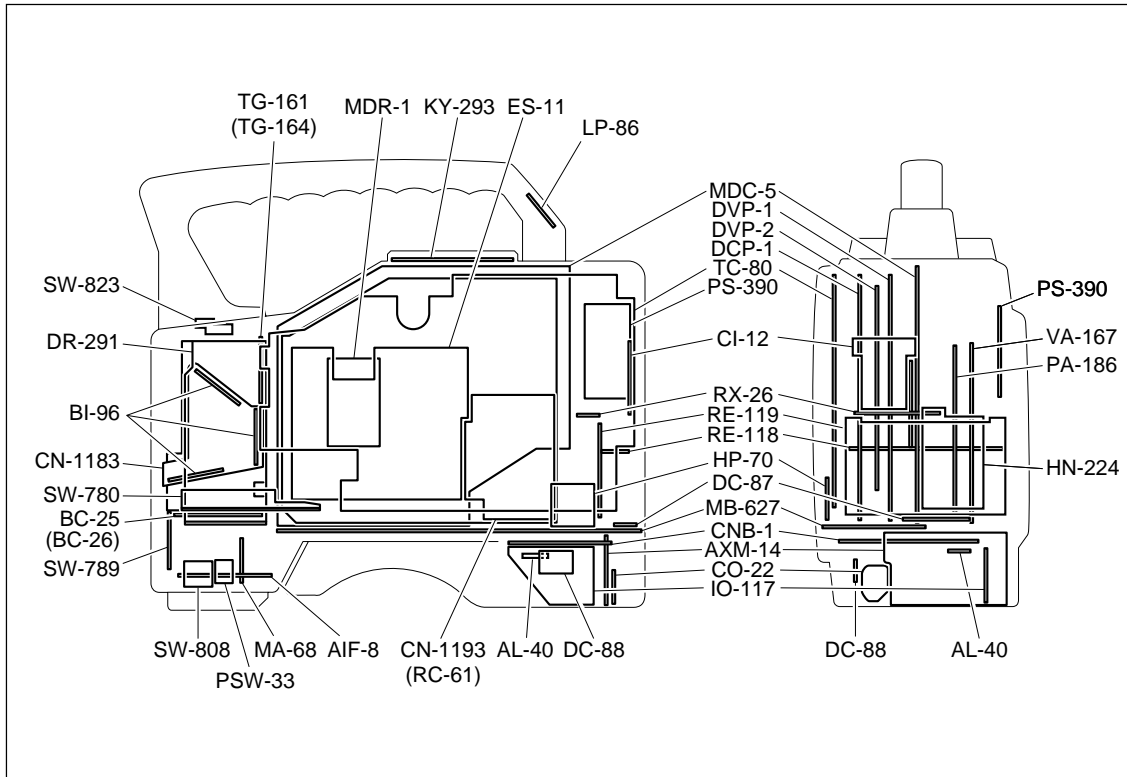

System	Board name	Function name
CCD BLOCK	BI-96	CCD Imager (R, G, B)
	CN-1183	Connector Board for BI-96
	DR-291	CCD Driver
	PA-186	Pre-amp(Sample & Hold)
	TG-161 *1	Timing Generator
	TG-164 *2	Timing Generator
	VA-167	Video Amp
CAMERA/VIDEO	CN-1193 *3	Connector Board for DCP-1
	RC-61 *4	Rate (16:9 to 4:3) Converter
	DCP-1	Camera Processor
	DVP-1	RF, Digital Audio Processor, Timing Clock Generator, System Controller for VTR Block
	DVP-2	Digital Bit Reduction Decoder, Digital Encoder, Digital Decoder
	ES-11	Composite Encoder
	TC-80	Analog Audio Processor, Time Code Generator
DRUM/SERVO	HN-224	Harness, TC Amp
	MDC-5	Servo Controller
	MDR-1	Drum Motor Driver
MICROPHONE	AIF-8	Lens Control, Mic Amp
	MA-68	Camera Mic Pre-amp
	SW-789	Mic Level, Auto White/Black Switch, VTR Start/Stop Switch, Shutter On/Off Select Switch
POWER SUPPLY	DC-87	Battery DC Filter
	PS-390	Power Supply (Light)
	RE-118	Regulator, Switching Control
	RE-119	Regulator
CONNECTOR BOX	AL-40	Audio CH-2 Line Out Amp
	AXM-14	Connector (AUDIO IN/OUT), Audio Pre-amp
	CNB-1	Circuit Breaker, Audio CH-1 Line Out Amp
	CO-22	Connector (VBS OUT)
	DC-88	External DC Filter
	IO-117	Connector (GEN LOCK IN, TEST OUT, TC IN, TC OUT)
OTHERS	CI-12	40-pin Adaptor Interface
	HP-70	Earphone
	KY-293	Function Key
	LP-86	Back Tally, Back Tally Switch
	PSW-33	Power Switch
	RX-26	Audio Pre-amp for Wireless Microphone
	SW-780	Switch Panel
	SW-808	Rotary Encoder Switch
	SW-823	Menu and Light Auto/Manual Switch
MB-627	Mother Board	

*1: For DNW-77P only

*2: For DNW-9WS/9WSP/90/90P/90WS/90WSP only

*3: For DNW-77P/90/90P only

*4: For DNW-9WS/9WSP/90WS/90WSP only

1-3-2. Location of Main Parts

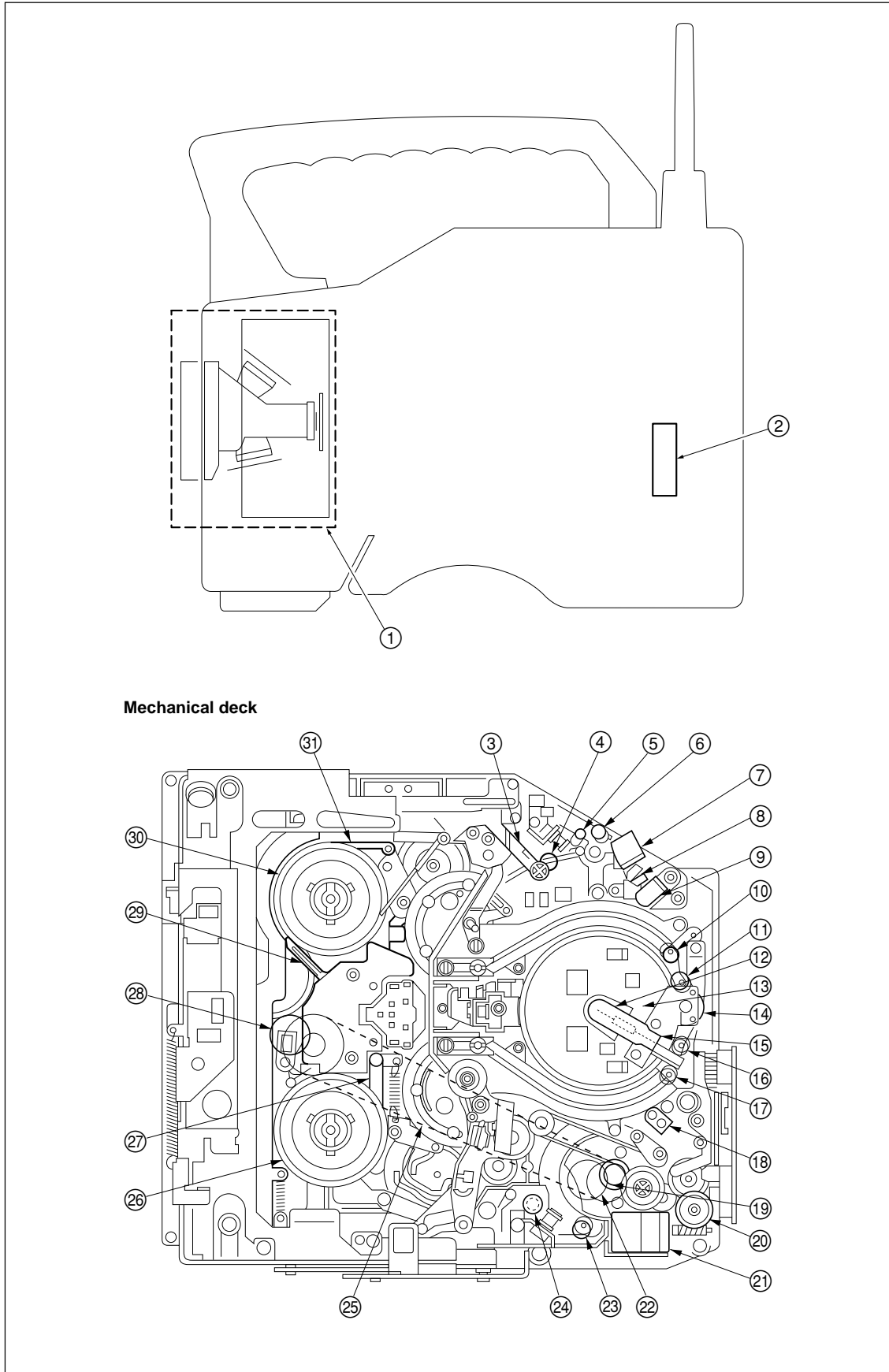

- ① : CCD block
- ② : Fan motor
- ③ : Tension regulator arm
- ④ : S5 tape guide
- ⑤ : Tension regulator guide (S4 tape guide)
- ⑥ : S3 tape guide
- ⑦ : Full erase head
- ⑧ : Tape cleaner
- ⑨ : CTL head
- ⑩ : S2 tape guide (on S slider)
- ⑪ : S1 tape guide (on S slider)
- ⑫ : Slip ring
- ⑬ : Drum
- ⑭ : Video head cleaner
- ⑮ : Brush
- ⑯ : T1 tape guide (on T slider)
- ⑰ : T2 tape guide (on T slider)
- ⑱ : TC head
- ⑲ : Capstan motor
- ⑳ : Manual eject knob
- ㉑ : Threading motor
- ㉒ : Pinch roller
- ㉓ : T3 tape guide
- ㉔ : T4 tape guide
- ㉕ : Timing belt
- ㉖ : T reel table
- ㉗ : T soft brake
- ㉘ : Gear
- ㉙ : S soft brake
- ㉚ : S reel table
- ㉛ : Tension regulator band

1-3-3. Location and Function of Sensors

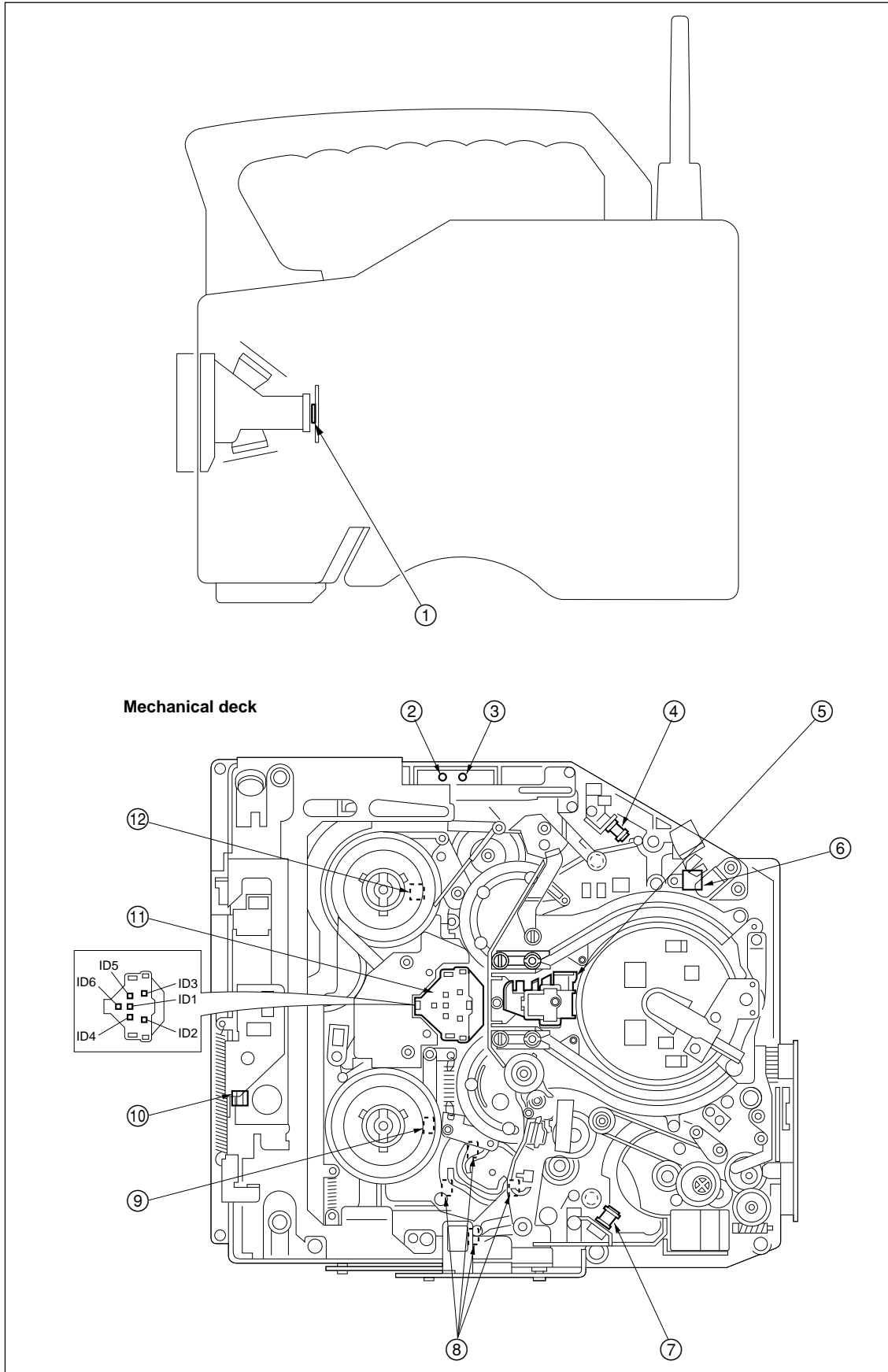

- ① : Temperature sensor
This sensor detects the temperature and then the fan motor is rotated.
- ② : Cassette-in sensor
This sensor detects the existence of a cassette.
- ③ : REC inhibit sensor
This sensor detects the REC inhibiting plug of the cassette tape.
- ④ : Tape end sensor
This sensor detects the end of the tape that runs in the forward direction.
- ⑤ : Full top sensor
This sensor detects whether the cassette tape is the full top.
- ⑥ : Condensation sensor
This sensor detects whether the dew condensation occurs in the unit.
- ⑦ : Tape top sensor
This sensor detects the end of the tape that runs in the reverse direction.
- ⑧ : Function cam sensor
This sensor detects the rotation position of a cam.
- ⑨ : Take-up reel table rotating sensor
This sensor detects the rotation of the take-up reel table. The FG output signal of this sensor is input to a servo circuit so as to calculate the winding diameter of the tape.
- ⑩ : Cassette lock sensor (switch)
This sensor detects that the cassette compartment was locked.
- ⑪ : Cassette ID sensors
 - ID1 : Tape type sensor
This sensor detects the tape type either an oxide or a metal.
 - ID2 : Tape thickness sensor
Using a tub on the back side of the cassette tape, this sensor detects the thickness of the tape wound on a cassette tape that is being inserted into the unit.
 - ID3 : Reel hub diameter sensor
The reel hub diameter of a cassette tape varies depending on the length of the tape wound on the cassette tape. The reel hub diameter sensor detects the reel hub diameter by the tab on the back side of the cassette tape.
 - ID4 to ID6 : Tape format sensors
These sensors detect the type of the cassette tape (for Betacam SX, Betacam SP and so on).
- ⑫ : Supply reel table rotating sensor
This sensor detects the rotation of the supply reel table. The FG output signal of this sensor is input to a servo circuit so as to calculate the winding diameter of the tape.

1-4. Matching Connectors

When external cables are connected to the connector during maintenance, the hardware listed below (or the equivalents) must be used.

Panel Indication	Matching Connector/Cable	
	Name of Connector/Cable	Part No.
AUDIO IN CH-1/CH-2	XLR 3-pin, male XLR 3-pin, female	1-508-084-00 (for SY) 1-508-083-00 (for J)
AUDIO OUT	Audio cable (XLR 5-pin – XLR 3-pin, 2m)	SONY CCXA-53 or equivalent
GENLOCK IN TC IN TC OUT TEST OUT VIDEO OUT	BNC	1-560-069-11
DC IN	XLR 4-pin, female	1-508-362-00
DC OUT 12 V	DIN 4-pin, male	1-566-425-11
MIC IN +48 V	XLR 3-pin, male	1-508-084-00
REMOTE	6-pin, male	1-560-078-00
EARPHONE	Mini jack	Standard product
LIGHT	Power tap [OE]	ANTONBAUER 33710 or equivalent

1-5. Signal Input and Output

INPUT

GENLOCK IN	1.0 V p-p, 75 Ω
TC IN	0.5 V to 18 V p-p, 10 k Ω
MIC IN	-60 dBu
AUDIO IN CH-1, CH-2	-60 dBu/+4 dBu (0 dBu = 0.775 Vrms)

OUTPUT

TEST OUT	1.0 V p-p, 75 Ω , unbalanced
TC OUT	1.0 V p-p, 75 Ω
VIDEO OUT	1.0 V p-p, 75 Ω , unbalanced
EARPHONE	$-\infty$ to -18 dBu, adjustable, 8 Ω
AUDIO OUT	0 dBm (600 Ω terminated)

DC IN: XLR 4-pin, male

<External View>



Pin No.	Signal
1	GND
2	-
3	-
4	EXT DC (DC 11 to 17 V)

BATT IN: 5-pin, male

<External View>

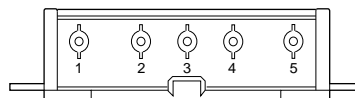

Pin No.	Signal
1	BATT IN (-)
2	BATT IND
3	BATT REM
4	LIGHT CONT
5	BATT IN (+)

DC OUT 12V: DIN 4-pin, female

<External View>



Pin No.	Signal
1	UNREG GND
2	-
3	-
4	UNREG +12 V (11 to 17 V, 0.1 A MAX)

AUDIO OUT: XLR5-pin, male

<External View>

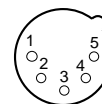

Pin No.	Signal
1	GND
2	CH1 (X)
3	CH1 (Y)
4	CH2 (X)
5	CH2 (Y)

VF: 20-pin, female

<External View>

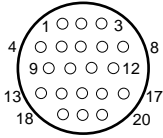

Pin No.	Signal
1	VTR SAVE
2	ABNORMAL
3	16:9/4:3
4	REC (L)
5	COLOR VF DET
6	CCIR/EIA
7	DISPLAY ON
8	G TALLY
9	-
10	Y (X)
11	ZEBRA ON
12	VIDEO (X)
13	AUDIO CTL
14	B-Y (X)
15	R-Y (X)
16	BATT IND
17	REC/TALLY
18	+9.3 V
19	GND
20	UNREG

REMOTE: 6-pin, female

<External View>

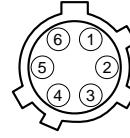

Pin No.	Signal
1	SD (RM)
2	SD (RM) I/O
3	UNREG GND
4	RM TEST (X)
5	RM TEST (G)
6	UNREG +12 V

LIGHT: 2-pin, female

<External View>

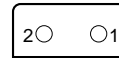

Pin No.	Signal
1	LIGHT +12 V (30W MAX)
2	GND

LENS: 12-pin, female

<External View>

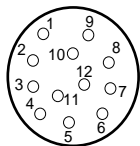

Pin No.	Signal
1	RET (SW)
2	VTR TRIG
3	LENS GND
4	AUTO +5 V
5	IRIS CONT
6	UNREG +12 V
7	IRIS POSITION
8	REMOTE/LOCAL
9	EXTENDER
10	ZOOM POSITION
11	N.C
12	N.C

1-6. Removal/Installation of Cabinet

Notes

- Be sure to turn off the power, then pull out the power cord and/or battery before performing the following procedure. If not, damage to internal circuit may result.
- The standard tightening torques of main screws used in this unit are as follows:
 - M1.4 (+) screw : $9 \times 10^{-2} \text{ N}\cdot\text{m}$ (0.9 kgf·cm)
 - M2 (+), M3 (+) and hexagon screws : $19 \times 10^{-2} \text{ N}\cdot\text{m}$ (1.9 kgf·cm)

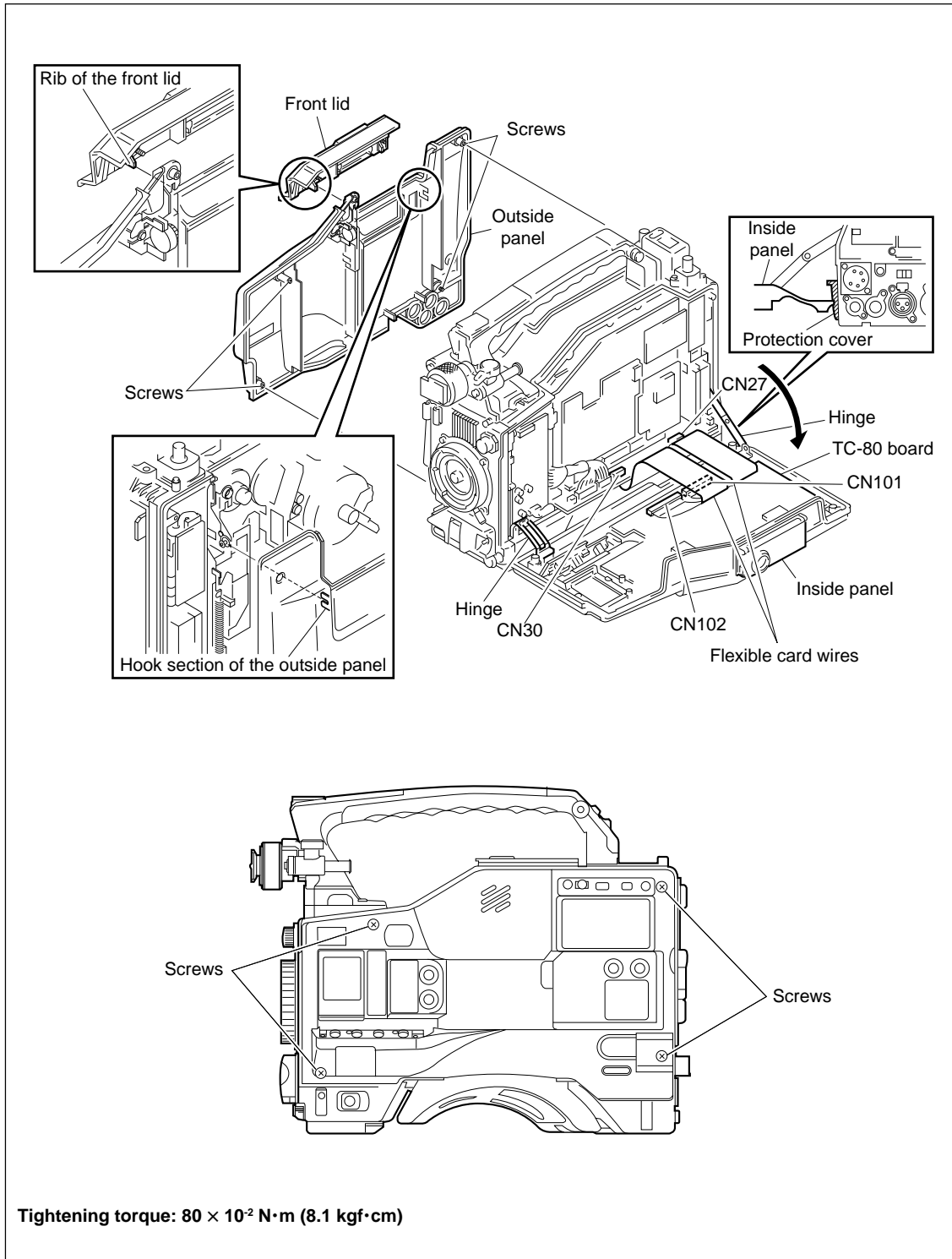

Front Lid

Loosen the two screws fully and remove the front lid. (Stoppers are provided for these screws.)

Note

Insert the rib of the front lid firmly into the groove during installation.

Outside panel

1. Remove the front lid.
2. Loosen the four screws fully and remove the outside panel. (Stoppers are provided for these screws.)

Note

Insert the hook section of the outside panel firmly into the guide shaft of the cassette compartment during installation.

Inside Panel

1. Loosen the four screws fully and open the inside panel in the direction indicated by the arrow. (Stoppers are provided for these screws.)

Notes

- Be careful not to bend the two flexible wires intentionally.
 - When opening, hook the inside panel on the protection cover of connector box to avoid damage to the cabinet.
2. Disconnect connectors CN27 and CN30 on the MB-627 board.
 3. Remove the flexible card wires from connectors CN101 and CN102 on the TC-80 board. (Refer to section 1-14.)
 4. Remove the two hinges.

Connector Box

Removal

1. Remove the front lid, inside panel, and outside panel.
2. Loosen the two screws fully and slide the shoulder pad forward. (Stoppers are provided for these screws.)
3. Remove the four screws, then remove the connector box.

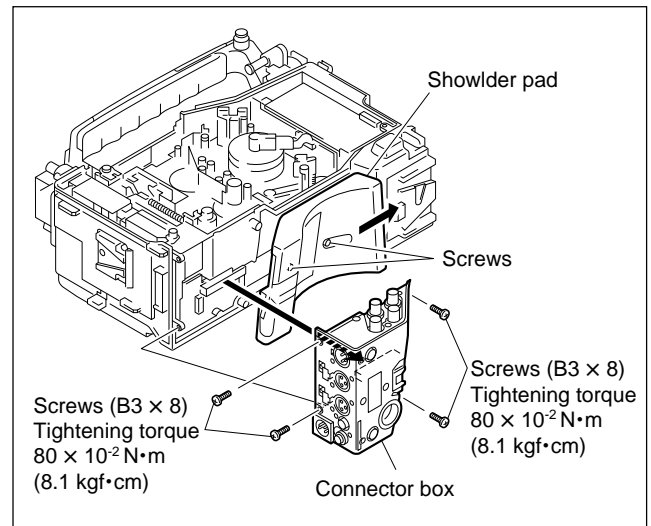

4. Disconnect connectors CN104 and CN105 on the CNB-1 board.

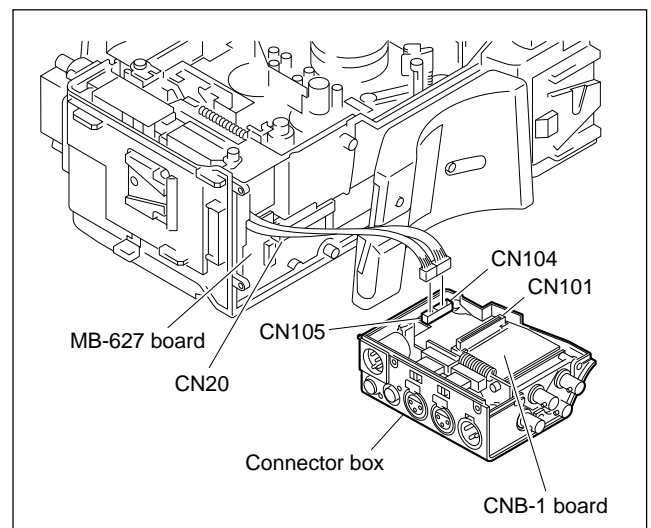

Cautions during Installation

1. Connect the connector CN20 on the MB-627 board securely to the connector CN101 on the CNB-1 board in the connector box.
2. Connect the connectors CN104 and CN105 on the CNB-1 board, after attaching the connector box to the unit.
3. Be careful not to get caught the harness in the rib.

1-7. Removal/Installation of Cassette Compartment

Notes

- Be sure to turn off the power, then pull out the power cord and/or battery before performing the following procedure. If not, damage to internal circuit may result.
- The cassette compartment can be removed even if it comes up or goes down.

Removal

1. Remove the front lid and outside panel.
(Refer to section 1-6.)
2. Remove the three screws, hold the position of the cassette compartment shown in the figure, and remove it in the direction indicated by the arrow.

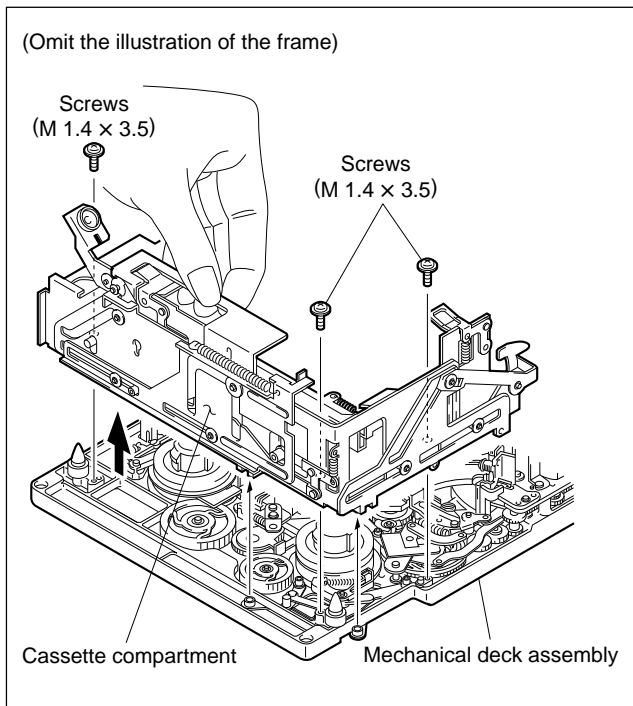

Installation

1. Adjust the position of the joint arm so that the clearance between the white roller's outer circumference of a joint arm and the end face of the mechanical deck assembly is 0.5 mm.

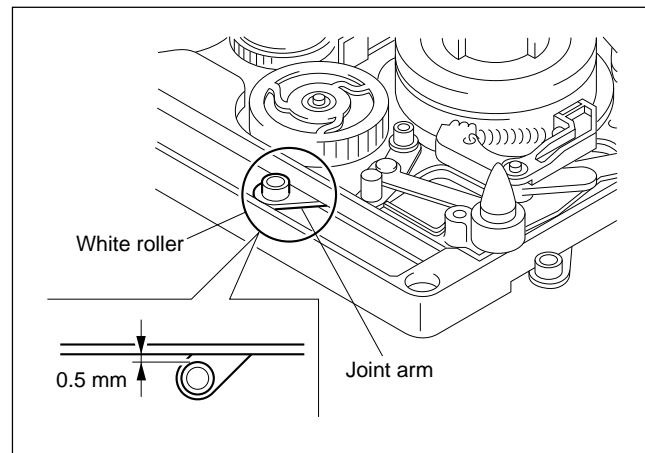

2. Raise the white lock roller of the cassette compartment so that it comes up.

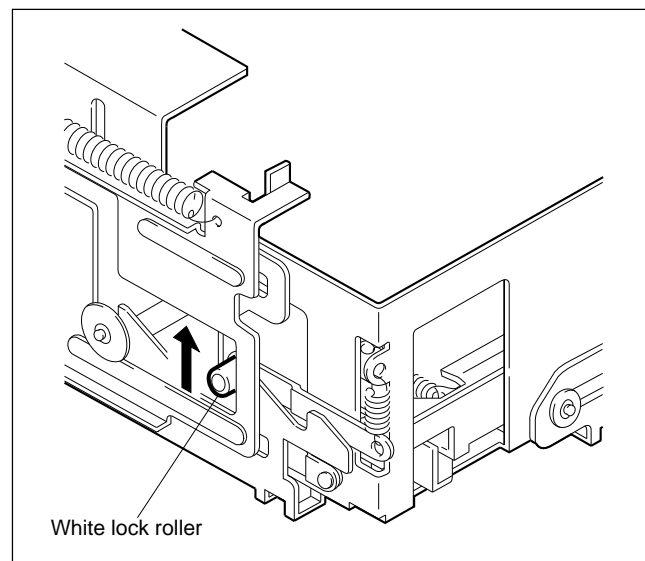

3. Move the cam plate (A) on the right side of the cassette compartment in the direction of the arrow with fingers as far as it will go.

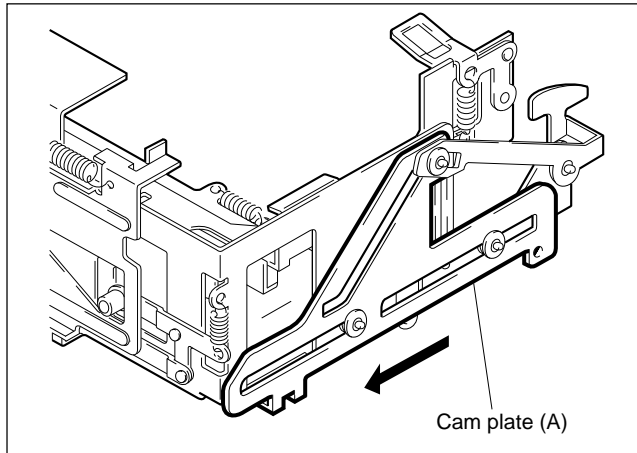

4. Hold the position of the cassette compartment shown in the figure and attach two cassette guide pins in the chassis so that they are put in the round holes of the stage.
 At that time, confirm that the other white roller of the joint arm positioned in step 1 is put in the notch of the cam plate (A) on the right side.
5. Push the lever of the cassette compartment and confirm that the stage smoothly moves up and down.
 If not, re-confirm steps 1 to 4.
6. Attach the cassette compartment with three screws.

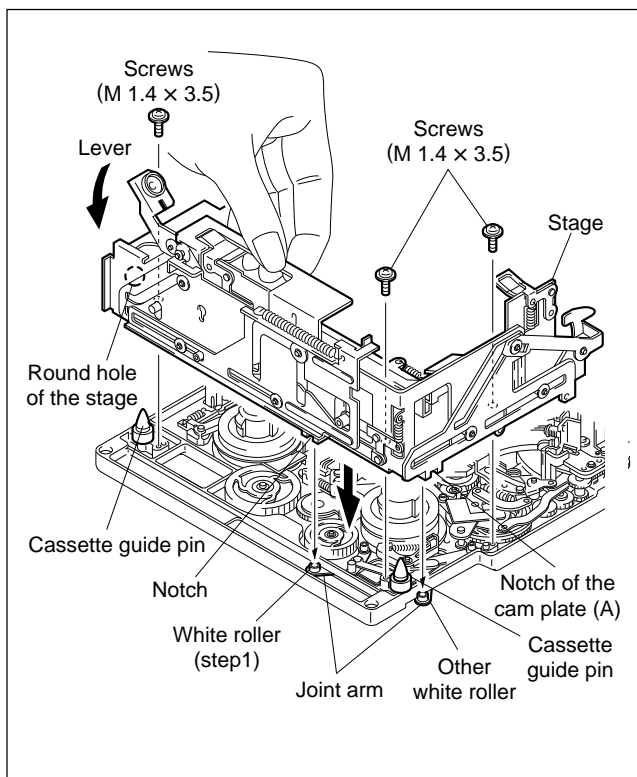

1-8. Pulling Out and Inserting the Plug-in Boards

Be careful attention so that the parts on the board are not damaged and the board is positioned and oriented correctly when pulling out and inserting the plug-in boards.
 Replace each board after confirming the setting of switches and slit lands. (Refer to section 1-9.)
 For the adjustment after board replacement, refer to “5. General Information for Electrical Alignment” of the Maintenance Manual Part 2 Vol-1.

Pulling out the plug-in board

1. Open the levers and disconnect the plug-in board from the connectors on the MB-627 board.
2. Pull out the plug-in board.

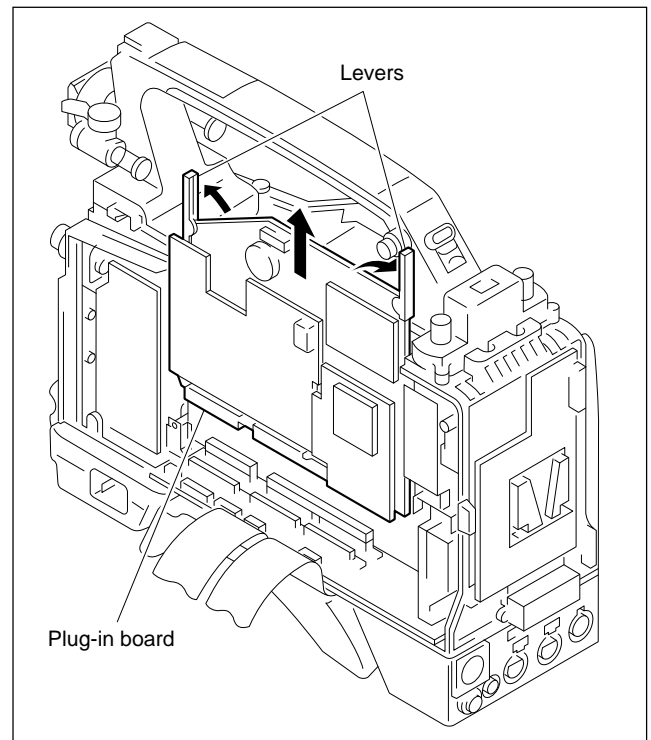

Inserting the plug-in board

1. Insert the plug-in board along the board guide rails.
2. Connect the connectors of the plug-in board to the connectors on the MB-627 board securely. Be sure to insert the plug-in board with levers in a horizontal position.

1-9. Switch/Slit Land Settings on the Boards

Note

For the factory-use switch and slit land, do not change the switch and slit land settings.

1-9-1. AXM-14 Board

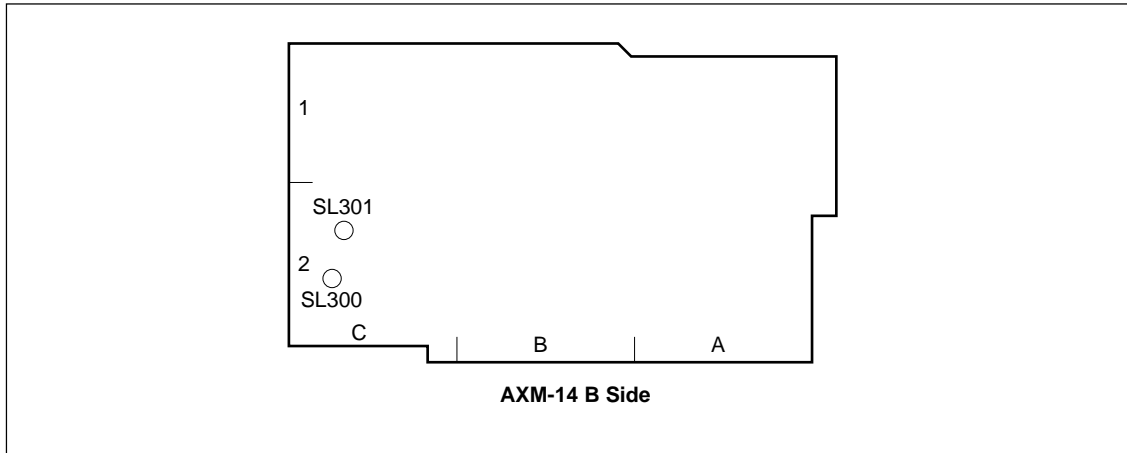

Slit Lands

Ref. No.	Name	Description	Factory setting
SL300	AUDIO OUT Select	OPEN : Outputs from the XLR 5-pin connector. SHORT: Outputs from the XLR 3-pin connector. ^{*2}	OPEN
SL301	AUDIO OUT Select	OPEN : Outputs from the XLR 3-pin connector. ^{*2} SHORT: Outputs from the XLR 5-pin connector.	SHORT ^{*1}

*1: This slit land is short-circuited by the traces on the board. Therefore, the traces must be cut using a knife when the setting is changed.

*2: The modification of the unit is necessary for change of the connector.

1-9-2. CNB-1 Board

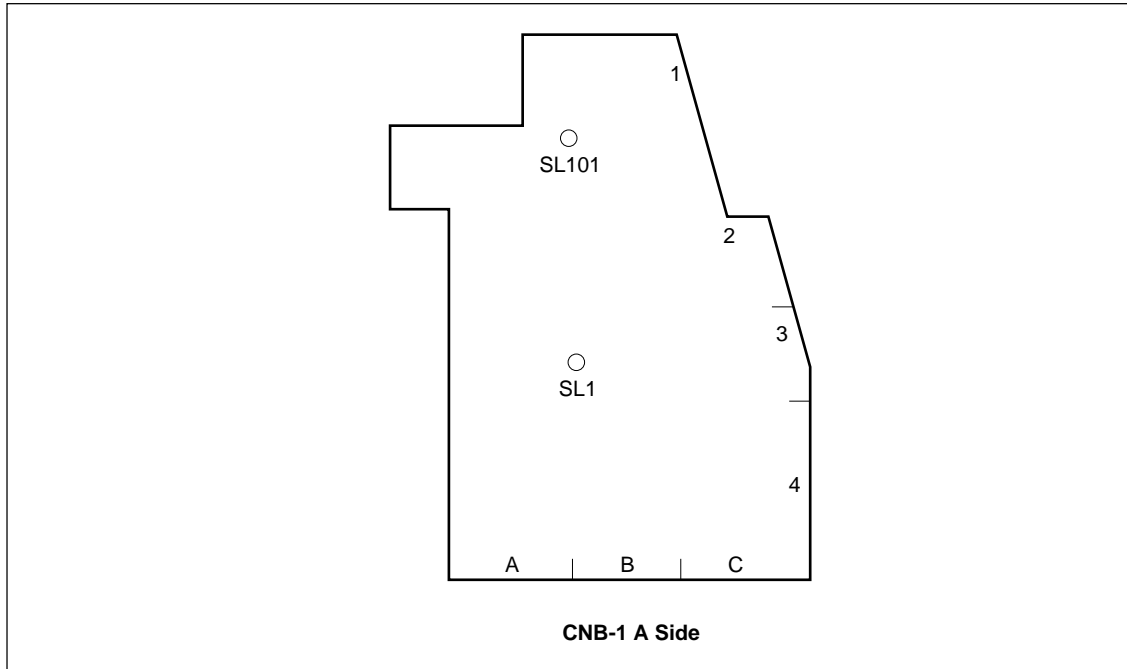

Slit Land

Ref. No.	Description	Factory setting
SL1	Destination Select	OPEN : For except Japan SHORT : For Japan

Note

Set SL1 according to the destination during board replacement.

SL101 Power supply select

Slit short : Supplies electric power from the battery to the unit automatically when the external power supply voltage is lower than the battery voltage.

Slit open : Supplies electric power from the external power supply to the unit irrespective of the voltage level of the external power supply when the electric power is supplied from the external power supply.

Power supply select

Slit		Input voltage	Input voltage
		EXT DC > BATT	EXT DC < BATT
SL101	SHORT	EXT DC	BATT
	OPEN (Factory setting)	EXT DC	EXT DC

1-9-3. DVP-1 Board

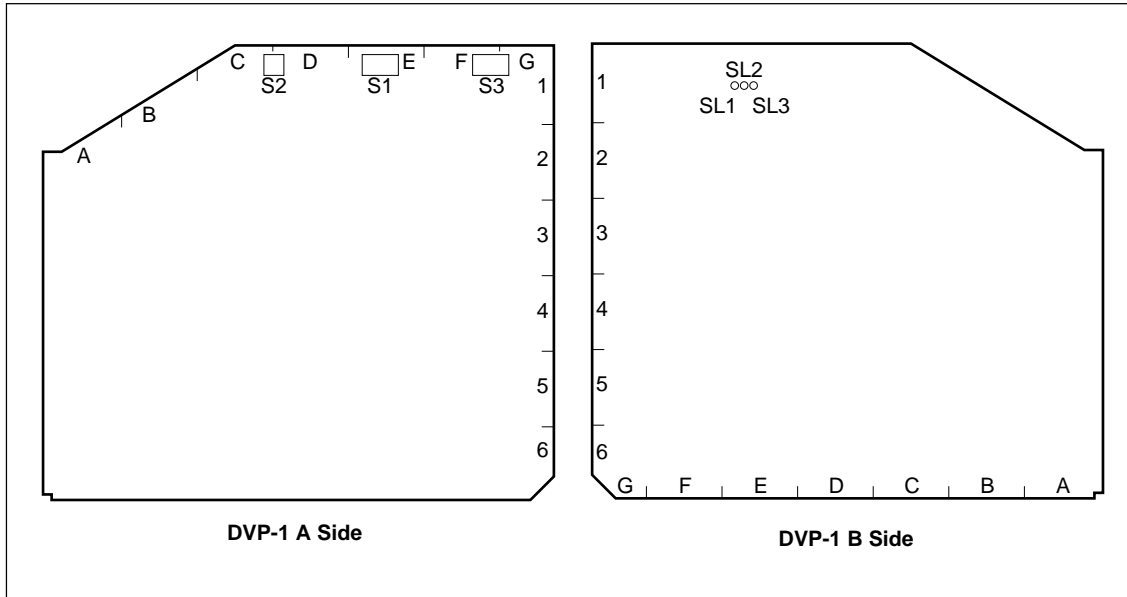

Switches

Ref. No	Name	Description	Factory setting
S1-1	Destination Select	OFF : NTSC ON : PAL	OFF (for NTSC) ON (for PAL)
S1-2	Model Select	OFF : DNW-7/7P/9WS/9WSP/90/90P/90WS/ 90WSP ON : DNV-5	OFF
S1-2 to 8	–	Not used	OFF
S2-1 to 3	–	Factory use	OFF
S2-4	Model Select	ON : DNW-9WS/9WSP/90/90P/90WS/90WSP OFF : DNV-5, DNW-7/7P	ON (for DNW-9WS/ 9WSP/90/90P/90WS/ 90WSP) OFF (for DNV-5, DNW-7/7P)
S3-1 to 8	–	Not used	OFF

Slit lands

Ref. No.	Description	Factory setting
SL1	Factory use	OPEN
SL2	Factory use	SHORT
SL3	Factory use	SHORT

1-9-4. DVP-2 Board

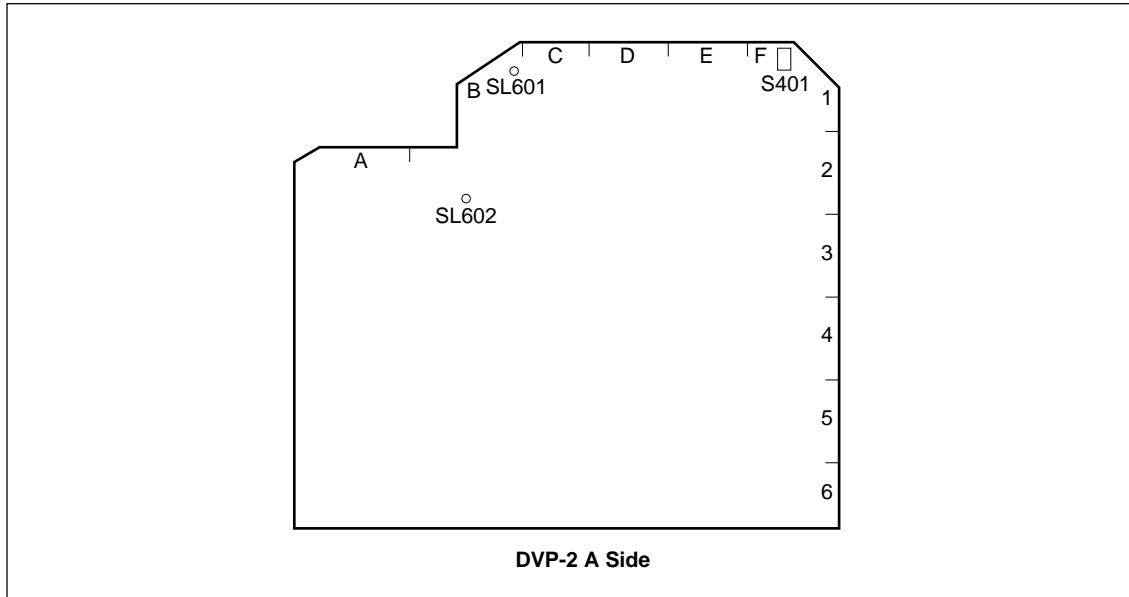

Switches

Ref. No.	Name	Description	Factory setting
S401-1	–	Factory use	OPEN
S401-2	–	Not used	OPEN

Slit Lands

Ref. No.	Description	Factory setting
SL601	Factory use	OPEN
SL602	Factory use	SHORT

1-9-5. TC-80 Board

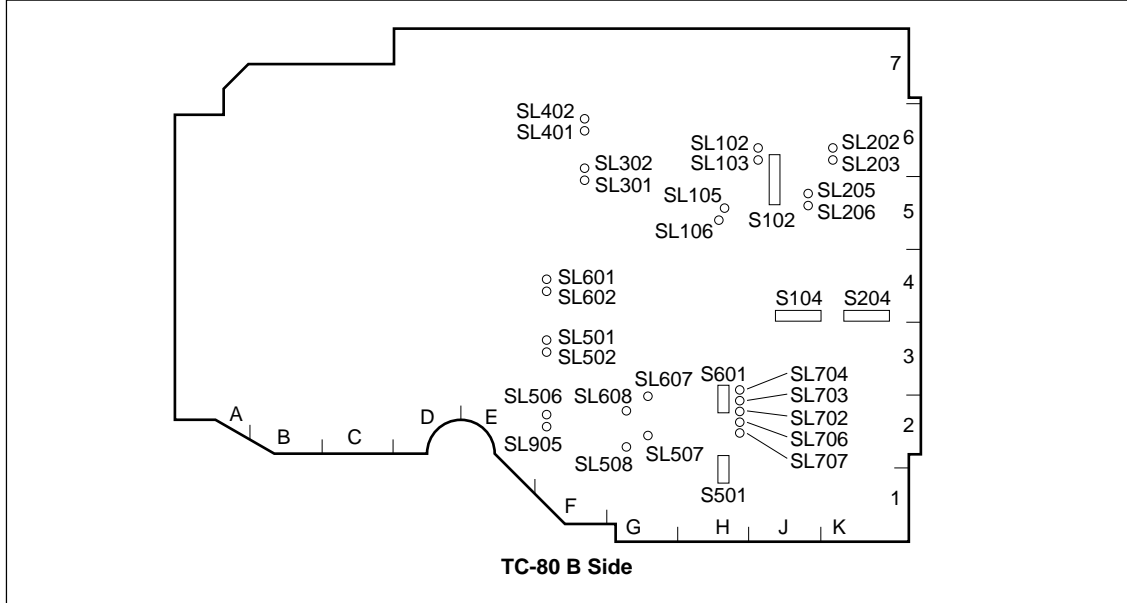

Switches

Ref. No.	Name	Description	Factory setting
S102	CH-1 Front MIC LEVEL Control	Selects whether to control CH-1 audio level of rear input by using the front MIC LEVEL control. ON : Enables OFF : Disables	OFF
S104	CH-1 Limiter	CH-1 Limiter OFF/ON	OFF
S204	CH-2 Limiter	CH-2 Limiter OFF/ON	OFF
S501	CH-1 Output Limiter	CH-1 Output Limiter OFF/ON (+10 dB limit)	ON
S601	CH-2 Output Limiter	CH-2 Output Limiter OFF/ON (+10 dB limit)	ON

Slit Lands

Headroom Level Select for Input Signal (Factory setting:20 dB)

Audio Channel	Ref. No.	Head room (dB)		
		20	18	16
CH1 *1	SL102	OPEN	SHORT	OPEN
	SL103	OPEN	OPEN	SHORT
AGC CH1	SL105	OPEN	OPEN	SHORT
	SL106	OPEN	SHORT	OPEN
CH2 *1	SL202	OPEN	SHORT	OPEN
	SL203	OPEN	OPEN	SHORT
AGC CH2	SL205	OPEN	OPEN	SHORT
	SL206	OPEN	SHORT	OPEN
AGC CH3	SL301	OPEN	SHORT	OPEN
	SL302	OPEN	OPEN	SHORT
AGC CH4	SL401	OPEN	SHORT	OPEN
	SL402	OPEN	OPEN	SHORT

*1: This switch setting is enable to select when the AUDIO SELECT switch on the inside panel is selected MANU.

Headroom Level Select for Output Signal (Factory setting:20 dB)

Audio Channel	Ref. No.	Head room (dB)		
		20	18	16
CH1	SL501 *1	OPEN	SHORT	OPEN
	SL502 *1	OPEN	OPEN	SHORT
CH2	SL601 *1	OPEN	SHORT	OPEN
	SL602 *1	OPEN	OPEN	SHORT

*1: TC-80 board number suffix : -12 and higher

Ref. No.	Name	Description	Factory setting
SL506	CH1 Monitor Select	<p>OPEN : Selects the output signal of the CH-1 outputs connector using the MONITOR select switch on the inside panel. Set SL506 and SL905 are the different positions.</p> <p>SHORT : Outputs the CH-1 signal to the CH-1 output connector.</p>	SHORT*2

*2: This slit land is short-circuited by the traces on the board. Therefore, the traces must be cut using a knife when the setting is changed.

Setting the Audio Output Level (Factory setting:0 dBm)

Audio Channel	Ref. No.	Output Level (dBm)			
		+4	0		
CH1	SL507	SHORT	OPEN	←	Set the same positions.
	SL508	SHORT	OPEN		
CH2	SL607	SHORT	OPEN	←	Set the same positions.
	SL608	SHORT	OPEN		

Ref. No	Name	Description	Factory setting
SL702	–	Factory use	SHORT
SL703	–	Factory use	SHORT
SL704	–	Factory use	SHORT
SL706	–	Factory use	SHORT
SL707	–	Factory use	SHORT
SL905	CH1 Monitor Select	<p>SHORT : Selects the output signal of the CH-1 output connector using the MONITOR select switch on the inside panel. Set SL506 and SL905 are the different positions.</p> <p>OPEN : Outputs the CH-1 signal to the CH-1 output connector.</p>	OPEN

1-9-6. MDC-5 Board

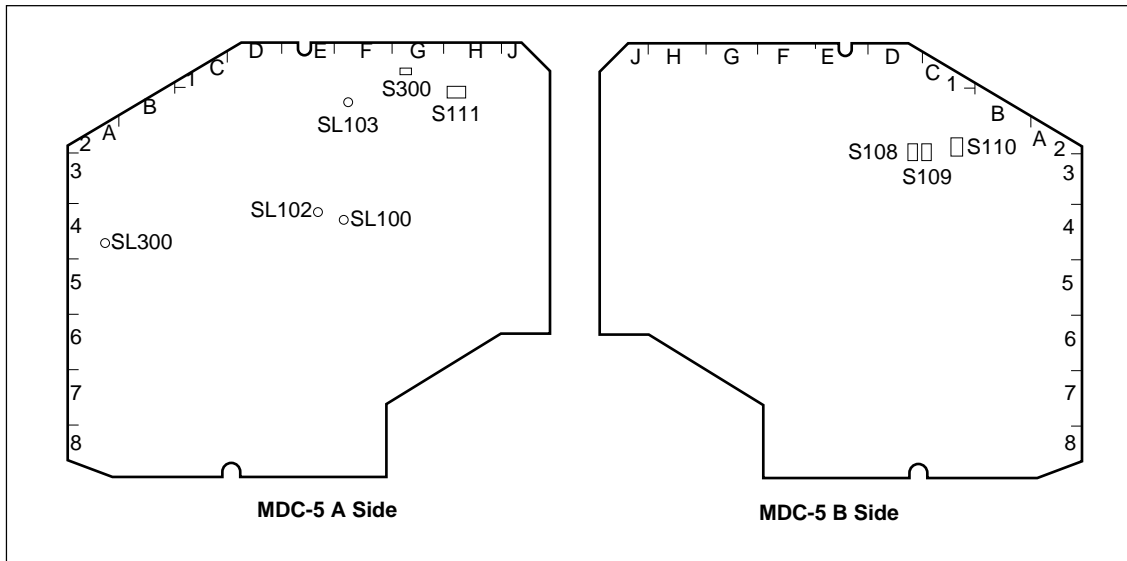

Switches

Ref. No.	Description	Factory setting
S108	Adjustment Mode Select	–
S109	Adjustment Start	–
S110-1	Adjustment Mode ON/OFF	OFF
S110-2	Tracking Adjustment	OFF
S111-1	Board Adjustment Mode OFF/ON	OFF
S111-2	Not used	OFF
S300	Factory use	–

Slit Lands

Ref. No.	Description	Factory setting
SL100	Factory use	SHORT
SL102	Factory use	SHORT
SL103	Factory use	OPEN
SL300	Factory use	SHORT

1-9-7. DCP-1 Board

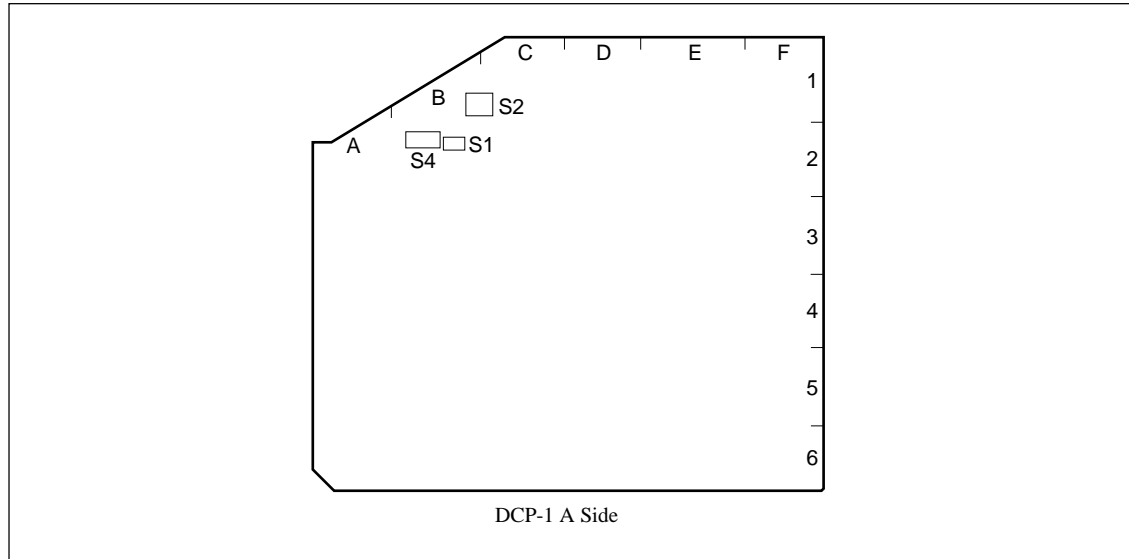

Switches

Ref. No.	Name	Description	Factory setting
S1	ENG Disable Select	ON : Disables OFF : Enables	OFF
S2	Character Select	Selects whether to display the character on the viewfinder and TEST OUT connector. 1: Both viewfinder and TEST OUT connector 2: Viewfinder only 3: TEST OUT connector only (For the character to be displayed on neither the viewfinder nor TEST OUT connector, set off the DISPLAY switch of the viewfinder.)	2
S4-1	–	Factory use	OFF
S4-2	Remote Connector	ON : Connects except RM-P9 and VA-DN1. OFF : Connects RM-P9 or VA-DN1.	OFF
S4-3	VF CAM Select	ON : Outputs the camera signal on the viewfinder when the OUTPUT switch is set BARS. OFF : Outputs the color bars signal on the viewfinder when the OUTPUT switch is set BARS.	OFF
S4-4	CAM Mode	OFF : Uses the VTR START button as the INCOM TALK ON button. ON : Uses the VTR START button as the RET 2 button. (When S4-4 is set ON, use the VTR SAVE/STBY switch as the INCOM TALK ON button.)	OFF
S4-5 to 7	–	Not used	OFF
S4-8	Data reset	ON : Resets in the setting menu when the power is turn on. OFF : Uses in normal times.	OFF

1-9-8. TG-164 Board (for DNW-9WS/9WSP/90/90P/90WS/90WSP only)

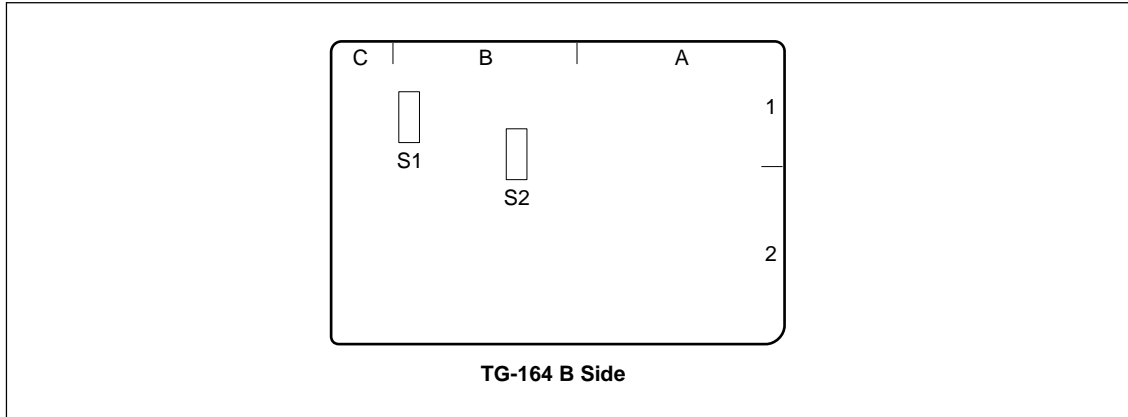

Switch

Ref. No.	Name	Description
S1	Model Select	4:3 16:9
S2 *1	Model Select	FIT IT

*1: Board suffix -13 and higher. (When board suffix is -11 or -12, not use for DNW-9WS/9WSP.)

Model Select

Model	S1	S2
DNW-9WS/9WSP	16:9	IT
DNW-90/90P	4:3	FIT
DNW-90WS/90WSP	16:9	FIT

1-10. Ejecting the Cassette Tape Manually

Note

Be sure to turn off the power, then pull out the power cord and/or battery before performing the following procedure. If not, damage to internal circuit may result.

1. Open the cover of the outside panel shown in the figure.
2. Turn the gear clockwise while pushing a gear downward until the front lid opens using a Philips screwdriver. Then confirm that the tape is taken up the cassette reel.
3. The front lid opens. The cassette tape can then be ejected.

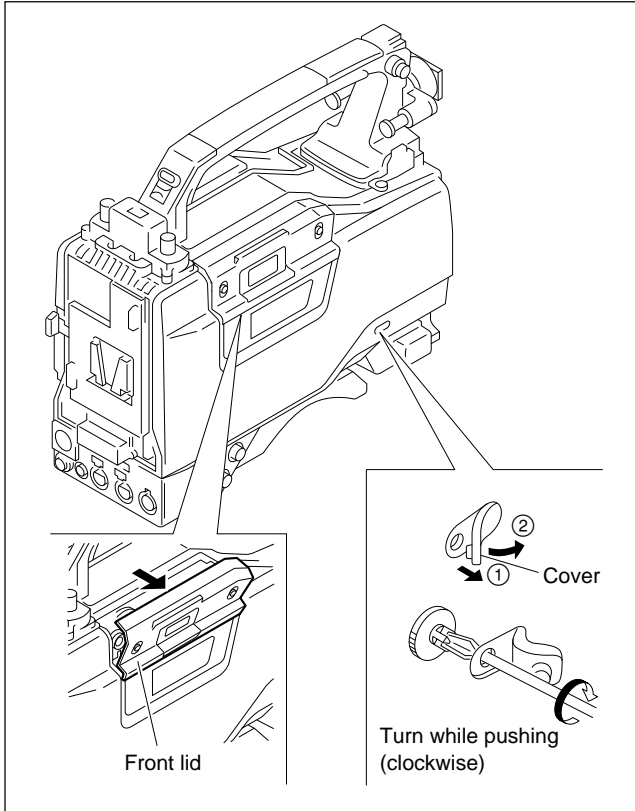

Notes

- Never turn the gear no further after the front lid opened.
If the gear is turned moreover, gear phase will be out of order, and then the operation timing of the cleaning roller will be shifted.
When performing the phase adjustment of the gear, refer to section 3-3-4. Timing Belt (Threading) Replacement of maintenance manual part2 volume1.
- Closing the front lid
In the state mentioned above, the front lid cannot be closed and locked. Turn on the power, then close the front lid.

If the above operation cannot be executed, perform the following procedures.

1. Remove the front lid and outside panel.
(Refer to section 1-6.)
2. Put the cassette compartment into the cassette-up state with the cassette lid of the cassette tape raised.
(For more details, refer to section 1-7.)
3. Remove the cassette tape taking care that the tape does not get damage.

1-11. Inserting the Cassette Tape when the Outside Panel is Removed

1. Place the cassette compartment into the up state.
(Refer to section 1-7.)
2. Insert a cassette tape in the cassette compartment.
3. Insert a screwdriver into the hole of cassette compartment shown in the figure, move it in the direction indicated by the arrow until it locks into place.

Note

Never push the lid arm (L) when placing the cassette compartment into the down state. The lid arm (L) become deformed, and the front cover can not be locked when the outside panel is installed.

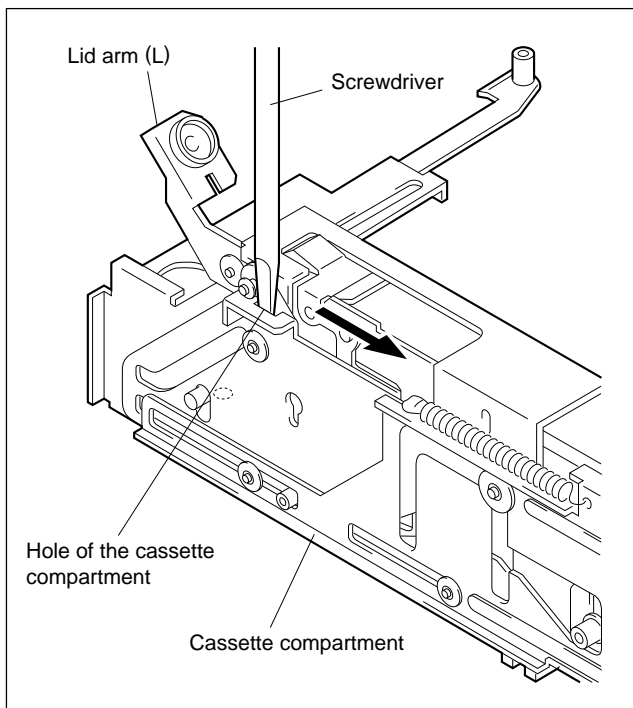

1-12. Cleaning when the Heads are Clogged

If the video heads are clogged, clean the heads as the following procedures.

If the video heads are still clogged after cleaning by the cleaning tape, clean them by cleaning cloth.

1-12-1. Cleaning by Cleaning Tape

Note

Make sure to use the cleaning tape BCT-5CLN. If cleaning is performed by other kind of cleaning tape, unusual wearing or damage of the video heads, may occur.

1. Insert the cleaning tape BCT-5CLN in the unit.
2. Press the PLAY button.
Head cleaning starts.
3. After 5 seconds, press the EJECT button.
4. The cleaning tape will be ejected.

Note

Be sure to take out the cleaning tape after cleaning to avoid damages to the heads.

5. Confirm that the head clog is clear.

1-12-2. Cleaning by Cleaning Cloth

Notes

- Turn off the power before cleaning.
- Each block in the mechanical deck consist of precision parts and are adjusted precisely. Be careful not to damage each part and to apply an excessive force during cleaning.
- Do not touch the greased portions during cleaning. If grease attaches to a cleaning cloth, replace the cleaning cloth by a new one. If a cleaning cloth smeared with grease is used, grease may attach to the places where it should not.
- Do not insert a cassette tape before a cleaning fluid completely evaporate after cleaning.
- Be sure to rotate the upper drum counterclockwise during cleaning. Clean the upper drum along the circumference. If the upper drum is cleaned in the vertical direction, the rotary heads may be damaged.

Tools

- Cleaning cloth : 3-184-527-01
- Cleaning fluid : 9-919-573-01

Note

Never use a cotton swab to clean the rotary heads.

Cleaning the Video Heads

1. Remove the front lid and outside panel.
(Refer to section 1-6.)
2. Press the cleaning cloth moistened with cleaning fluid slightly against the position of the rotary heads installation height.
3. Rotate the upper drum slowly in the counterclockwise direction by hands and clean it.
4. After cleaning, wipe the upper drum with dry cleaning cloth.

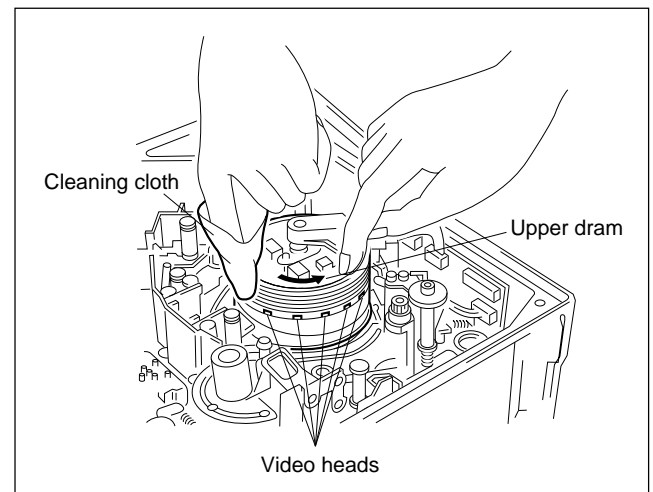

Cleaning the Stationary Heads and Tape Guides

1. Remove the front lid and outside panel.
(Refer to section 1-6.)
2. Wipe the stationary heads and tape guides using the cleaning cloth moistened with cleaning fluid.
3. After cleaning, wipe the stationary heads and tape guides with dry cleaning cloth.

1-13. Backup Battery

The lithium battery for data backup operation is mounted on the TC-80 board. Replace the lithium battery every five years. For more details of the replacement, refer to “1-3. Lithium Battery Replacement” of the Maintenance Manual Part 2 Vol-1.

1-14. Removal/Installation of Flexible Card Wires

Notes

- Be sure to turn off the power, then pull out the power cord and/or battery before performing the following procedure. If not, damage to internal circuit may result.
- Two 30-pin flexible card wires are used between the MB-627 and the TC-80 boards. Be careful not to break these flexible card wires. This shortens the wire life.

Removal

1. Slide portions A in the direction indicated by the arrows, unlock it, then pull out the flexible card wire.

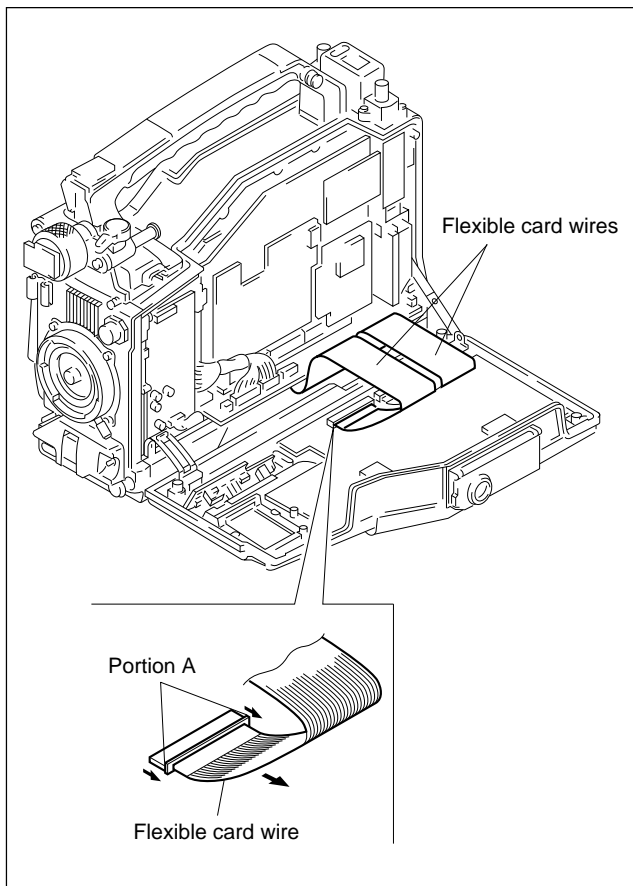

Installation

1. Check that the conductive surface of the flexible card wire is not soiled with dust.
2. Slide portions A in the direction indicated by the arrows and insert the flexible card wire tightly into each connector with the conductive surface of these wire put down.

Note

Be careful not to insert the flexible card wire obliquely.

3. Slide portions A in the reverse direction of the arrows and lock each connector.

1-15. Fixtures

1-15-1. Extension Boards

Extension boards are optionally available to check and adjust the boards in the table below. Use the extension boards in the procedure below, then perform to check and adjust the boards.

Extension board	Board to be checked and adjusted
EX-501	DVP-1, DVP-2
	DCP-1, ES-11, CN-1193 *1, RC-61 *2
EX-541, EX-542	MDC-5

*1: For DNW-77P/90/90P only

*2: For DNW-9WS/9WSP/90WS/90WSP only

Using the EX-501 board

1. Remove the board to be extended (DVP-1 or DCP-1 board).
2. Connect the EX-501 board to the connector on the MB-627 board.
3. Connect the board (DVP-1 or DCP-1) to be extended to the EX-501 board.

Note

When to remove the connected board from the EX-501 board, insert the tip of a flat-blade screwdriver into the section marked with "EJECT", turn the screwdriver, and remove the board.

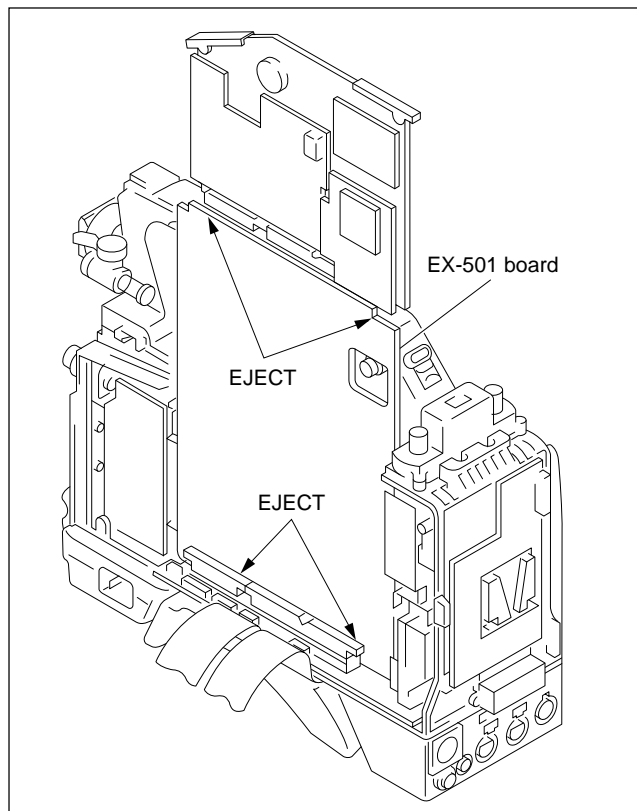

Using the EX-541 and EX-542 boards

1. Remove the DVP-1 and DCP-1 boards.
2. Remove the eight screws, then remove the shield cover on the MDC-5 board.
3. Connect the EX-541 board to connectors CN3 and CN4 on the MB-627 board.
4. Connect the EX-542 board to connectors CN1 and CN2 on the MB-627 board.

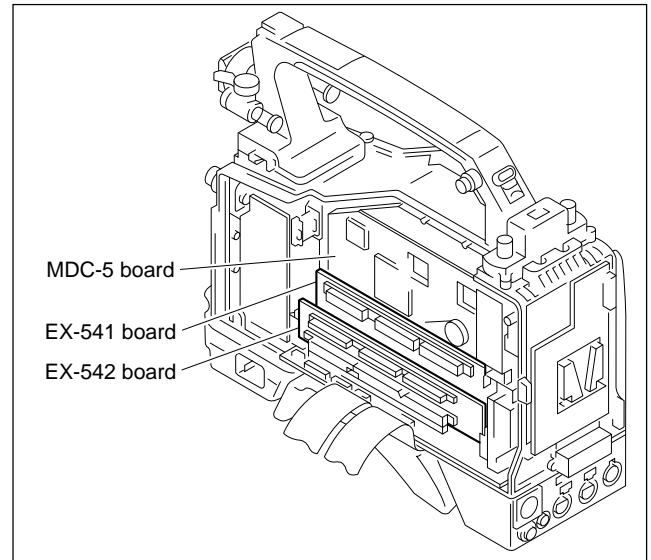

5. Connect the DVP-1 board to the EX-541 board.
6. Connect the DCP-1 board to the EX-542 board.
7. Install the two stays in the hooks and fix the DVP-1 and DCP-1 boards shown in the figure.

Note

When to remove the connected boards from the EX-541 and EX-542 boards, insert the tip of a flat-blade screwdriver in the section marked with "EJECT", turn the screwdriver, and remove the board.

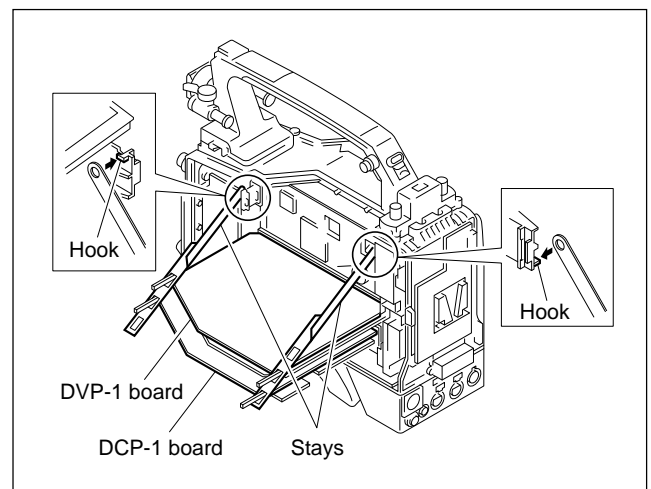

1-15-2. Fixtures

Fig. No.	Description	Name	For use
1	A-8315-553-A	HN-255 Assembly (TP Tool)	Video tracking adjustment
	A-8315-552-A	IF-701 Assembly (EQ Tool)	Equalizer adjustment
2	A-8312-804-A	Extension Board Assembly (EX-501/541/542, Stays)	Plug-in board check/adjustment
	A-8277-713-A	EX-501 Extension Board	
	A-8277-714-A	EX-541 Extension Board	
	A-8277-715-A	EX-542 Extension Board	
3	J-6026-100-A	Resolution Chart (4:3)	Camera adjustment
	J-6395-320-A	Resolution Chart (16:9) *1	
	J-6026-110-A	Burst Chart	
	J-6026-130-A	Gray Scale Chart (4:3)	
4	J-6394-080-A	Gray Scale Chart (16:9) *1	
5	J-6029-140-B	Pattern Box, PTB-500	
6	J-6035-070-A	IC External Tool (ICT-2101)	Extraction of IC (PLCC type)
7	J-6080-840-A	Inspection Mirror	Video tracking adjustment
8	J-6152-450-A	Wire Clearance Check Gauge	Clearance check
9	J-6322-420-A	Tape Guide Adjustment Driver (45)	Tape path adjustment
	J-6322-420-3	TG Driver Spare Bit (45)	
10	J-6323-530-A	Stop Washer Fastening Tool	Installation of stop washer
11	J-6323-890-A	FWD Back Tension Measuring Cassette	FWD back tension adjustment
12	J-6324-150-A	Reel Table Height Adjustment Tool	Reel height adjustment
13	J-6325-110-A	Torque Driver Bit (for M1.4)	Tightening screws
	J-6325-380-A	Torque Driver Bit (for M2)	
14	J-6325-400-A	Torque Driver Bit (for 3 kg)	
15	J-6326-120-A	Hexagonal Bit	
16	J-7032-610-A	Cassette Reference Plate	Reel height adjustment
17	3-184-527-01	Cleaning Cloth	Cleaning
18	3-703-358-08	Parallel Pin	Mechanical adjustment
19	7-651-000-10	Grease, SGL-601 (50 g)	Lubricant
	7-651-000-11	Grease, SGL-801 (50 g)	
20	7-661-018-18	Oil	
21	7-700-736-05	Hexagonal Wrench (d = 1.5 mm)	Removal of screws
22	8-960-075-01	Alignment Tape, SR5-1	Digital video/audio adjustment (NTSC)
	8-960-075-11	Alignment Tape, SR2-1	Video tracking adjustment (NTSC)
	8-960-075-51	Alignment Tape, SR5-1P	Digital video/audio adjustment (PAL)
	8-960-075-61	Alignment Tape, SR2-1P	Video tracking adjustment (PAL)
23	9-919-573-01	Cleaning Fluid	TTP cleaning
–	7-432-114-11	Locking compound	
–	Product	Blank Tape, BCT-30MA or Betacam SX Video Cassette, BCT-60SX	For recording
		Cleaning Tape, BCT-5CLN	Cleaning
		Screw Locking Compound	

*1: For DNW-9WS/9WSP/90WS/90WSP only

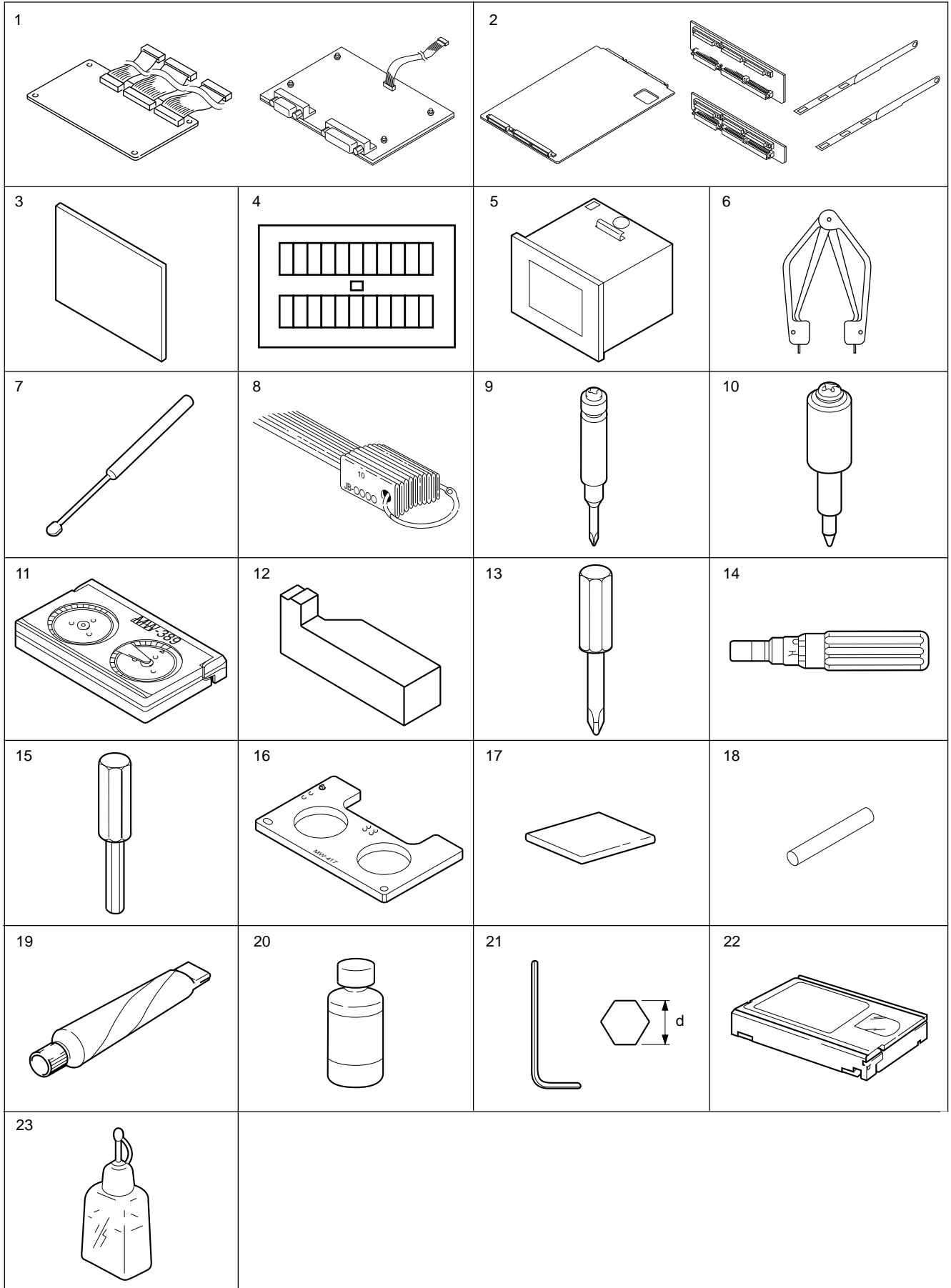

Section 2 Error Code

2-1. Error Code

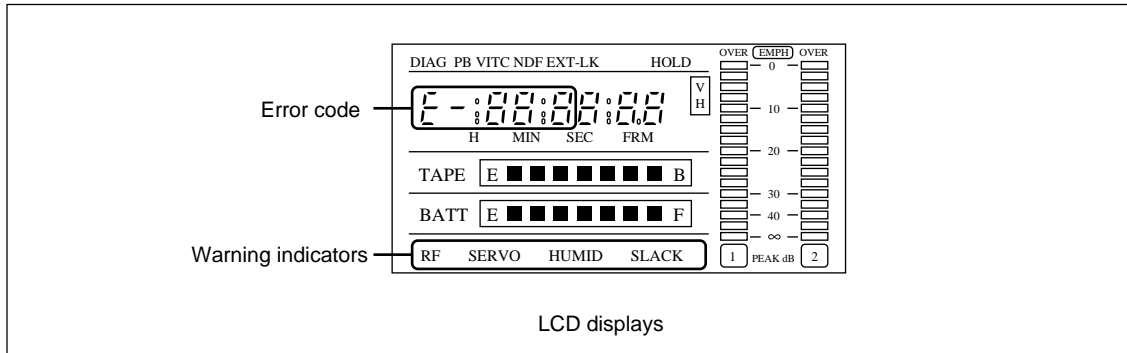

2-1-1. Warning Indicators

The warning indicator on the LCD screen lights if any fault occurs during the power-on sequence or normal operation. And the tally indicator on the viewfinder, back tally and warning indicators blink at the same time.

- RF : Lights if video heads are clogged.
- SERVO : Lights if the servo fails.
Lights if the communication error is occurred between system control IC (DVP-1 board) and servo IC (MDC-5 board)
- HUMID : Lights if there is condensation in the unit.
- SLACK : Lights if the tape is not winding properly or the following troubles (refer to “Error Codes”) are occurred.

2-1-2. Error Codes

When “SLACK” of the warning indicator lights, error causes and its operating status are displayed on the LCD display.

<p><i>E-XXXX</i></p> <p>↑ ↑</p> <p>MODE</p> <p><i>0</i>: POWER ON</p> <p><i>1</i>: REC</p> <p><i>2</i>: REC PAUSE</p> <p><i>3</i>: THREAD</p> <p><i>4</i>: UNTHREAD</p> <p><i>5</i>: STOP</p> <p><i>8</i>: PLAY</p> <p><i>9</i>: FF</p> <p><i>F</i>: REW</p> <p><i>b</i>: REC REVIEW</p> <p><i>⌈</i>: CUE UP</p> <p><i>E</i>: FF SEARCH</p>	<p><i>F</i>: REW SEARCH</p> <p>ERROR CAUSE</p> <p><i>10</i>: Drum drive voltage abnormality</p> <p><i>11</i>: Detects no drum FG</p> <p><i>12</i>: Detects no drum PG</p> <p><i>20</i>: Capstan drive voltage abnormality</p> <p><i>21</i>: Detects no capstan FG-A</p> <p><i>22</i>: Detects no capstan FG-B</p> <p><i>23</i>: Capstan rotation abnormality in forward and reverse directions</p>	<p><i>24</i>: Capstan speed abnormality (high speed)</p> <p><i>32</i>: Detects no S reel FG</p> <p><i>42</i>: Detects no T reel FG</p> <p><i>51</i>: Fuction cam rotation overtime in the forward direction</p> <p><i>52</i>: Fuction cam rotation overtime in the reverse direction</p> <p><i>53</i>: Tape top sensor overtime</p> <p><i>54</i>: Full top sensor overtime</p> <p><i>55</i>: End sensor overtime</p> <p><i>70</i>: Servo NVRAM checksum error</p> <p><i>71</i>: Communication error between servo CPUs</p>
--	---	--

2-2. Error Messages

The error message is superimposed on the viewfinder screen if any fault occurs during the power-on sequence or normal operation.

Error message	Operation	Remedy
STORED DATA:NG	Blinks on the viewfinder screen during the power-on sequence.	The white and/or black balance memory data have been lost. Adjust the white and black balance again.
CAM?	Displayed during the power-on sequence or normal operation.	A fault has been detected in the camera. Consult the Sony service engineer.
VTR?	Displayed during the power-on sequence or normal operation.	A fault (HUMID or SLACK) has been detected in the VTR. Check the warning indicators on the LCD display.

Section 3

Maintenance Mode

3-1. Setup Menu

This unit has the SETUP menu required for the settings and adjustments of the camera.
This section describes the ENG mode.

Data structure

The menu has the following data structure.

Set value of the data (or adjust value) = fixed data in the unit (absolute value) + set value of the ENG mode (relative value)
+ set value of the USER mode (relative value)

- When adjustment is performed using the ENG mode, the values of items adjusted in the USER mode become 0.
- The set values of the USER mode and ENG mode are stored separately in the setup card.

Switch description

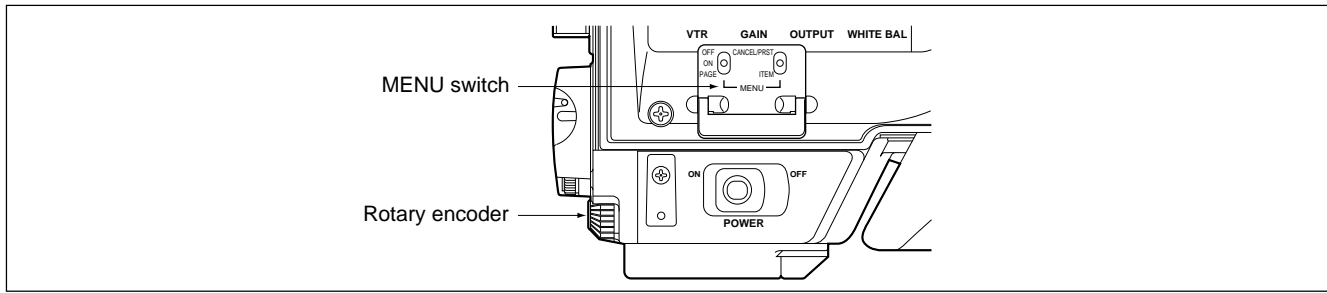

1. MENU switch

- OFF : Terminate the SETUP menu.
Usually, set to OFF.
- ON : Execute the SETUP menu.
- PAGE : Search page of the SETUP menu.
- CANCEL/PRST: Cancel the setting value (during level control) or reset to the factory-setting value.
- ITEM : Select item.

2. Rotary encoder

Rotary encoder uses to change the set value of selected item or to decide the changed setting value.

Operation

The SETUP menu is set to the USER mode when shipped from the factory.

Perform the following procedures to enter the ENG mode.

1. Turn the main power off.
2. Set the switch S4-1 on the DCP-1 board to OFF.
3. Set the switch S1 on the DCP-1 board to OFF.
4. While holding the rotary encoder down, turn the main power on.

Setting Change (MENU switch operation)

1. To select the page, throw the MENU switch to PAGE. The page will be shifted to the next page every time the switch is thrown to PAGE.
2. To select the item, throw the MENU switch to ITEM. The cursor pointing the item will be shifted to the next item every time the switch is thrown to ITEM. By pressing the rotary encoder, selected item is entered.
3. To change the setting value, turn the rotary encoder.
4. To exit from the SETUP menu, set the MENU switch to OFF.

Setting Change (Rotary encoder operation)

1. To select the page, turn the rotary encoder until the desired page is appeared and press it down.
2. To select the item, turn the rotary encoder until the cursor pointing the item is shifted to the desired item and press it down.
(When pressing the rotary encoder down with the cursor pointing the title of item, the menu display will be returned to the state in procedure 1.)
3. To change the setting value, turn the rotary encoder.
4. When pressing the rotary encoder down again, the menu display will be returned to the state in procedure 2
5. To exit from the SETUP menu, set the MENU switch to OFF.

Note

When the unit is externally controlled by the remote control unit RM-P9, some functions cannot be controlled. (Refer to pages 3-17 to 3-23.)

Pages configuration of the SETUP menu

Viewfinder screen (Factory default setting)	Description
*** MARKER 1/2 ***	
SAFETY ZONE : ON Sets the safety zone marker display to ON or OFF.
SAFETY AREA : 90 % Sets the safety zone area to 80 %, 90 % or 100 %.
CENTER : ON Sets the center marker display to ON to OFF.
CENTER H Moves the center marker horizontally.
CENTER V Moves the center marker vertically.
*** MARKER 2/2 ***	
BOX CURSOR : OFF Sets the box cursor display to ON or OFF. *1
BOX WIDTH Changes the width of the box cursor.
BOX HEIGHT Changes the height of the box cursor.
BOX H Moves the box cursor horizontally.
BOX V Moves the box cursor vertically.
** VF DISPLAY 1/2 **	
DISP MODE : 3 Set whether to display the items partially or to display no item. (1/2/3) For details, refer to the Operation Manual.
EXTENDER : ON Sets the extender display to ON or OFF.
ZOOM : ON Sets the zoom position display to ON or OFF.
** VF DISPLAY 2/2 **	
FILTER : ON Sets the filter display to ON or OFF.
WHITE : ON Sets the white balance display to ON or OFF.
GAIN : ON Sets the gain selection value display to ON or OFF.
SHUTTER : ON Sets the shutter speed/mode display to ON or OFF.
TAPE : ON Sets the tape remaining display to ON or OFF.
AUDIO : ON Sets the CH-1 audio level display to ON or OFF.
IRIS : ON Sets the iris value display to ON or OFF.
*** MASTER GAIN ***	Sets the gain corresponding to the LOW, MIDDLE, HIGH and TURBO positions of the gain selector switch.
LOW : 0 dB	Selects a GAIN value from -3, 0, 3, 6, 9, 12, 18, 24, 30, 36, or 42 dB .
MID : 9 dB	Selects a TURBO value from -3, 0, 3, 6, 9, 12, 18, 24, 30, 36, or 42 dB.
HIGH : 18 dB	Note
TURBO : 36 dB	When the gain selection value is changed, the BLACK SET adjustment (Section 8-13) is required.
*** SHOT ID ***	Sets the shot ID of a maximum of twelve characters using alphanumeric character, symbol, and space.
ID-1 : □□□□□□□□□□□□	
ID-2 : □□□□□□□□□□□□	
ID-3 : □□□□□□□□□□□□	
ID-4 : □□□□□□□□□□□□	

*1 : The box cursor is not functioned in the following conditions (DNW-9WS/9WSP/90WS/90WSP only).

1. Set the "BOX/4:3 LIMITS" to 4:3 at WIDE SCREEN page.
2. Set the "BOX/4:3 LIMITS" to 4:3, and "VF ASPECT" to 16:9A or 16:9B at WIDE SCREEN page.

Viewfinder screen (Factory default setting)	Description
* SHOT DATA DISP. *	Sets the contents of the shot data to be recorded on tape
DATE : OFF Sets whether to display/record the date. (ON/OFF only)
TIME : OFF Sets whether to display/record the time. (ON/OFF only)
MODEL NAME : OFF Sets whether to display/record the model name (ON/OFF only)
SERIAL NO. : OFF Sets whether to display/record the serial No. (ON/OFF only)
CASSETTE NO. : OFF Sets whether to display/record the cassette No.. (ON/OFF only)
SHOT NO. : OFF Sets whether to display/record the shot No.. (ON/OFF only)
ID SELECT : OFF Sets whether the any specific shot ID displays/records. (OFF/ID1/ID2/ID3/ID4)
*** SHUTTER SPEED ***	Sets the shutter speed/mode selection range.
EVS : ON Enhanced Vertical Definition mode (DNW-7 only) Super Enhanced Vertical Definition mode (DNW-90/90WS only)
CLS : ON CLS : Clear scan mode ECS : Extended clear scan mode (DNW-90/90WS only)
1/100 (for NTSC) or 1/60 (for PAL) : ON Shutter speed 1/100 (for NTSC) or 1/60 (for PAL) second in the standard mode
1/125 : ON Shutter speed 1/125 second in the standard mode
1/250 : ON Shutter speed 1/250 second in the standard mode
1/500 : ON Shutter speed 1/500 second in the standard mode
1/1000 : ON Shutter speed 1/1000 second in the standard mode
1/2000 : ON Shutter speed 1/2000 second in the standard mode
*** ! LED ***	
MASTER GAIN : ON Sets whether to light the ! indicator LED on the viewfinder when the gain is set except 0 dB.
SHUTTER : ON Sets whether to light the ! indicator LED on the viewfinder when the SHUTTER selector switch is set to ON.
WHITE PRESET : OFF Sets whether to light the ! indicator LED on the viewfinder when the white balance memory is set to PRESET.
ATW RUN : OFF Sets whether to light the ! indicator LED on the viewfinder when the ATW (automatic homing white balance) is operating.
EXTENDER ON : ON Sets whether to light the ! indicator LED on the viewfinder when the lens extender is used.
FILTER 2,3,4 : OFF Sets whether to light the ! indicator LED on the viewfinder when the FILTER selector is set except 1. (Standard setting is 1.)
A. IRIS OVERRIDE : OFF Sets whether to light the ! indicator LED on the viewfinder when the reference value of the automatic iris adjustment is set to any value other than the standard value.
*** SETUP CARD ***	
READ (→ CAM) Reads data from the setup card.
WRITE (→ CARD) Writes data to the setup card.
ID EDIT Sets ID of the setup card.
WRITE PROTECT Sets the WRITE PROTECT function of the setup card . (ENG mode only)

Viewfinder screen (Factory default setting)	Description
** FUNCTION 1/2 **	
TEST OUT : ENC	<p>..... Selects the ENC, R, G or B signal of the video signal output from the TEST OUT connector.</p> <p>Note</p> <p>When the R-G/B-G SEL item on the OP MODE page is set to ON, the R-G and B-G items are added enabling to select R-G and B-G.</p>
DETAIL : ON	<p>..... Sets whether to add the detail signal for resolution improvement to the video signal.</p> <p>Note</p> <p>The level adjustment for this item is performed on the "LEVEL 1" page.</p>
APERTURE : ON	<p>..... Sets the aperture correction to ON or OFF.</p>
SKIN TONE DTL : OFF	<p>..... Sets whether to activate the skin tone detail circuit.</p> <p>Note</p> <p>The level adjustment for this item is performed on the "LEVEL 2" page.</p>
MATRIX : OFF (for NTSC) : ON (for PAL)	<p>..... Sets whether to activate the linear matrix circuit.</p> <p>The highly color saturation can be obtained when this item is set to ON.</p> <p>Note</p> <p>The level adjustment for this item is performed on the "LEVEL 8" page.</p>
GAMMA : ON	<p>..... Sets whether to implement the gamma correction so that the overall characteristic of signals from the camera to monitor display is "GAMMA = 1".</p> <p>Note</p> <p>The level adjustment for this item is performed on the "LEVEL 3" and "LEVEL 6" pages.</p>
CHROMA : ON	<p>..... Sets whether to add the chroma signal.</p> <p>Note</p> <p>The level adjustment for this item is performed on the "LEVEL 4" page.</p>
TEST SAW : OFF	<p>..... Sets whether to close the lens forcibly and add the TEST SAW waveform to the video signal circuit.</p> <p>This signal is used for the video signal system adjustment.</p>
CROSS COLOR FLT : OFF (for NTSC only)	<p>..... Sets whether to reduce the cross color of a video signal. The cross color is reduced when this item is set to ON.</p>

Viewfinder screen (Factory default setting)	Description
** FUNCTION 2/2 **	
GENLOCK : ON Sets whether to synchronize the internal reference signal with the external input video signal supplied to the GENLOCK IN connector.
CAM RET. : OFF Sets whether to display the return video signal input to the GENLOCK IN connector on the viewfinder screen when the RET button is pressed ON.
FILTER INH. : OFF Sets whether to interlock the white balance correction value to the filter position. ON : The white balance correction value is not interlocked to the color temperature conversion filters ; The memory A and the memory B store one adjustment value respectively. OFF : The white balance correction values for the respective color temperature conversion filters are stored in the memories A and B. Four for memory A and four for memory B, total eight values can be stored.
FIELD/FRAME : FLD Sets the type of the CCD data read-out system. FLD : Field read mode. Normally set to this position. FRM : Frame read mode. This position is selected when improved vertical resolution is desired.
Note	
The frame read mode has more image lag than the field read mode.	
A. IRIS OVERRIDE : OFF Sets whether to activate the auto iris override function. When this item is set to ON, the reference value of the auto iris adjustment can be changed using the rotary encoder when menu is set to OFF. (Five steps : Irises off $-1/2$, $-1/4$, 0, $+1/4$, and $+1/2$)
DYNALATITUDE : OFF Sets whether to active the dynalatitude function. Detects a high contrast signal that white and/or black level becomes flat, and correct to the suitable contrast. (Four steps : OFF, LOW, MID and HI)
* WIDE SCREEN * (DNW-9WS/9WSP/90WS/90WSP only)	
16:9/4:3 MODE : 16:9 Sets the aspect ratio of the video signal output from the VIDEO OUT and TEST OUT connectors.
VF ASPECT : AUTO Sets the aspect ratio on the viewfinder. AUTO : Sets the aspect ratio set by 16:9/4:3 MODE setting. 4:3 : Sets the aspect ratio to 4:3 regardless of 16:9/4:3 MODE setting. 16:9A : Sets the aspect ratio to 16:9 regardless of 16:9/4:3 MODE setting (displays the area of 4:3 mode with the marker). 16:9B : Sets the aspect ratio to 16:9 regardless of 16:9/4:3 MODE setting (video level is cut in half out of the safety zone area on the VF screen).
BOX/4:3 LIMITS : BOX Sets the function of the box cursor. BOX : Operates as the normal cursor function. 4:3 : Displays the area of 4:3 mode when the 16:9/4:3 MODE set to 16:9.
"16:9" BARS ID : OFF Sets whether to add the "16:9" character in the color bars signal generated in this unit when the 16:9/4:3 MODE set to 16:9.
"16:9" VF ID : OFF Sets whether to add the "16:9" character on the VF screen when the 16:9/4:3 MODE set to 16:9.

Viewfinder screen (Factory default setting)	Description
** VF SETTING **	
ZEBRA 1 DETECT : 0 Sets the center level of the zebra 1 pattern.
ZEBRA 1 APT : 0 Sets the width of the zebra 1 pattern.
ZEBRA 2 DETECT : 0 Sets the lower-limit level of the zebra 2 pattern. The upper-limit level is the white clip level.
ZEBRA SELECT : 1 Sets the zebra patterns ZEBRA1/ZEBRA2/both.
	Note
	The zebra detection level can be measured on waveform monitor when the TEST OUT is set to any position other than ENC and the zebra switch on VF is set to ON.
VF VDTL LEVEL : 0 Set the level of the V detail signal of the video outputting to the viewfinder.
* LEVEL 1 *	
DETAIL LEVEL : 0 Sets the total level of the detail signal.
V DTL LEVEL : 0 Sets the level of the V detail. The H/V ratio is adjusted using this item.
APERTURE LEVEL : 0 Sets the high-frequency correction level.
KNEE APERTURE : 0 Sets the detail level after the gamma correction.
V DTL BLK CLIP : 0 Sets the clipping level in the negative (-) direction of the V detail.
DTL BLK CLIP : 0 Sets the clipping level in the negative (-) direction of the H detail.
LEVEL DEPEND. : MIN Sets the level of the skin tone detail amount in the low level.
CRISPENING : 4 Sets the crispening level of the detail signal.
H DTL FREQ. : 4 Sets frequency (amount) of the H detail.
* LEVEL 2 *	
SUPPRESS LEVEL : MIN]
X : 0	
Y : 0	
dX : 0	
dY : 0	
SKIN TONE DTL : OFF Sets whether to activate the skin tone detail function.
	Note
	This item is the same as the "SKIN TONE DTL" item on the "FUNCTION 1/2" page.
SKIN TONE IND. : OFF Sets whether to display the skin tone detection area. Disable this item during the color bars output. The indicator is automatically set to OFF when the POWER switch to OFF. Sets this item to OFF when the ZEBRA SELECT set to 2.
SKIN TONE DET. : OFF Set the skin tone automatic detection.

Viewfinder screen (Factory default setting)	Description
* LEVEL 3 *	
MASTER BLACK : 0 Sets the black level.
MASTER GAMMA : 0 Sets the gamma correction curve.
KNEE POINT 1 : 0 Used for the manual knee adjustment. Sets the knee point and slope.
KNEE SLOPE 1 : 0	
KNEE POINT 2 : 0 Used for the manual knee adjustment. Sets the knee point and slope.
KNEE SLOPE 2 : 0	
KNEE SELECT : 1 Sets the knee patterns KNEE1/KNEE2/OFF. The knee correction is forcibly canceled regardless of DCC ON/OFF setting when this item is set to OFF. Sets the knee correction set by KNEE POINT 1/KNEE SLOPE 1 setting when this item is set to 1.
WHITE CLIP : ON The white clip is forcibly canceled when this item is set to OFF. Used for the video system adjustment.
WHT CLIP LEV. : 0 Sets the white clip level.
* LEVEL 4 *	
BURST LEVEL : 0 Used for the chroma adjustment of the encoder.
BURST PHASE : 0 Used for the chroma adjustment of the encoder. (for PAL only)
R-Y : ON Sets whether to add the R-Y signal to the encoder circuit.
B-Y : ON Sets whether to add the signal to the encoder circuit.
R-Y LEVEL : 0 Used for the R-Y adjustment of the encoder. *1
B-Y LEVEL : 0 Used for the B-Y adjustment of the encoder. *1
Note	
The setting of the "CHROMA" item on the "FUNCTION 1/2" page has priority over the ON/OFF setting of the "R-Y" and "B-Y" items. When the CHROMA is set to ON, it automatically returns to ON by turning the power switch to ON/OFF even if the R-Y or B-Y item is to OFF. This item does not returns to ON when the "CHROMA" item is set to OFF.	
* LEVEL 5 *	
RGB LEVEL : 0 Sets the R/G/B video level. *1
RGB SYNC LEV. : 0 Sets the R/G/B sync level.
RGB SETUP LEV. : 0 Sets the R/G/B setup level.
ENC Y LEVEL : 0 Sets the encoder output Y level. *1
ENC SYNC LEV. : 0 Sets the encoder output sync level.
ENC SETUP LEV. : 0 Sets the encoder output setup level.

*1 : This level can be set in the 4:3/16:9 mode separately using DNW-90WS/90WSP.

Viewfinder screen (Factory default setting)	Description
* LEVEL 6 *	
R BLACK : 0] Sets the R/G/B black level.
G BLACK : 0	
B BLACK : 0	
R GAMMA : 0] Sets the R/G/B gamma correction curve.
G GAMMA : 0	
B GAMMA : 0	
BLACK STRETCH : 2 Stretch or compress the black gain.
TEST OUT : ENC Sets the type of the video signal output from the TEST OUT connector.
	Note Same as TEST OUT item of the "FUNCTION 1/2" page.
* LEVEL 7 *	
R FLARE : 0] Sets the R/G/B flare correction amount.
G FLARE : 0	
B FLARE : 0	
FLARE : ON Sets whether to activate the flare correction function.
TEST OUT : ENC Sets the type of the video signal output from the TEST OUT connector.
	Note Same as TEST OUT item of the "FUNCTION 1/2" page.
* LEVEL 8 *	
MATRIX TABLE : A Selects the matrix setting.
: B (for PAL)	When shipped from the factory, the same matrix is assigned for both A and B. The matrix coefficient can be freely changed to obtain a customers' desired color reproducibility.
R-G : 0] Sets the matrix coefficient.
R-B : 0	
G-R : 0	
G-B : 0	
B-R : 0	
B-G : 0	
MATRIX : OFF Sets whether to activate the linear matrix circuit.
: ON (for PAL)	Note Same as MATRIX item of the "FUNCTION 1/2" page.

Viewfinder screen (Factory default setting)	Description
* LEVEL 9 *	
H PHASE : -37 (PAL : -32) Sets the H phase of the camera in the external genlock mode.
SC PHASE : 0 Sets the SC phase of the camera in the external genlock mode.
SC 0/180 SELECT : 0 Inverts the SC phase of the camera in the external genlock mode. (Selects either 0 or 180 degrees.)
SC-H : 0 Sets the INT SC phase reference level.
IRIS SET : 0 Sets the auto iris reference level.
IRIS MODE : 0 Sets the auto iris control level.
 The more this set value increase, it approaches the average. The less this set value decreases, it approaches the peak. Monitor the level bar at the upper right on the viewfinder screen for this setting item to check that it approaches the peak level or average level. The "P" indication on the left of the level bar means the peak level. The "A" indication on the right of the level bar means the average level.
IRIS WEIGHT : 0 Sets the valid range of the auto iris. (The larger number make the valid range narrower.)
IRIS SPEED : 0 Sets the auto iris response speed.
CLIP HIGH LIGHT : OFF Limits the auto iris detection to 100% for the subject of high brightness (video level: 100% or more)
* W-SHAD._G *	
H SAW : 0] Sets the manual white shading correction amount of G signal.
H PARA : 0	
V SAW : 0	
V PARA : 0	
H SAW (EXT) : 0] Sets the manual white shading correction amount of G signal during the extender mode.
H PARA (EXT) : 0	
V SAW (EXT) : 0	
V PARA (EXT) : 0	
SHAD COMP : ON Sets whether to activate the shading correction on G signal.
TEST OUT : ENC Sets the type of the video signal output from the TEST OUT connector.
	Note
	Same as TEST OUT item of the "FUNCTION 1/2" page.

Viewfinder screen (Factory default setting)	Description
* W-SHAD._R *	
H SAW : 0] Sets the manual white shading correction amount of R signal.
H PARA : 0	
V SAW : 0	
V PARA : 0	
H SAW (EXT) : 0] Sets the manual white shading correction amount of R signal during the extender mode.
H PARA (EXT) : 0	
V SAW (EXT) : 0	
V PARA (EXT) : 0	
SHAD COMP : ON Sets whether to activate the shading correction on R signal.
TEST OUT : ENC Sets the type of the video signal output from the TEST OUT connector.
Note	
Same as TEST OUT item of the "FUNCTION 1/2" page.	
* W-SHAD._B *	
H SAW : 0] Sets the manual white shading correction amount of B signal.
H PARA : 0	
V SAW : 0	
V PARA : 0	
H SAW (EXT) : 0] Sets the manual white shading correction amount of B signal during the extender mode.
H PARA (EXT) : 0	
V SAW (EXT) : 0	
V PARA (EXT) : 0	
SHAD COMP : ON Sets whether to activate the shading correction on B signal.
TEST OUT : ENC Sets the type of the video signal output from the TEST OUT connector.
Note	
Same as TEST OUT item of the "FUNCTION 1/2" page.	
* B-SHAD._G *	
H SAW : 0] Sets the manual black shading correction amount of G signal.
H PARA : 0	
V SAW : 0	
V PARA : 0	
SHAD COMP : ON Sets whether to activate the shading correction on G signal.
TEST OUT : ENC Sets the type of the video signal output from the TEST OUT connector.
Note	
Same as TEST OUT item of the "FUNCTION 1/2" page.	

Viewfinder screen (Factory default setting)	Description
* B-SHAD._R *	
H SAW : 0] Sets the manual black shading correction amount of R signal.
H PARA : 0	
V SAW : 0	
V PARA : 0	
SHAD COMP : ON Sets whether to activate the shading correction on R signal.
TEST OUT : ENC Sets the type of the video signal output from the TEST OUT connector.
Note	
Same as TEST OUT item of the "FUNCTION 1/2" page.	
* B-SHAD._B *	
H SAW : 0] Sets the manual black shading correction amount of B signal.
H PARA : 0	
V SAW : 0	
V PARA : 0	
SHAD : ON Sets whether to activate the shading correction on B signal.
TEST OUT : ENC Sets the type of the video signal output from the TEST OUT connector.
Note	
Same as TEST OUT item of the "FUNCTION 1/2" page.	
* DCC ADJ. *	
D RANGE : 6 Sets the dynamic range during dynamic contrast control. (0 : approximately 300 %, 6 : approximately 600 %)
POINT : 0 Sets the minimum knee point during dynamic contrast control.
GAIN : 0 Sets the knee slope value during dynamic contrast control.

Viewfinder screen (Factory default setting)	Description
* OPERATION MODE 1 *	
R-G/B-G SEL. : OFF Sets whether to add the R-G and B-G signals to the TEST OUT setting of the setup menu.
GAMMA TABLE : A (PAL : B) Selects the characteristics of the gamma correction. More distinct black gradation is obtained when this item is set to B. Normally setting to A. A : Sony standard gamma curve B : High gain gamma curve
LOW LIGHT : OFF Sets the starting level of the LOW LIGHT display on viewfinder. OFF : No display 1 : Approx. 10 % 2 : Approx. 15 % 3 : Approx. 20 %
BARS SELECT : 1 Sets the type of built-in color bars signal 1 : SMPTE color bars 2 : EBU color bars (PAL)/Full color bars (NTSC) 3 : SNG color bars
WHITE B : AWB Sets the function of white balance (B-CH) AWB : Auto white balance ATW : Auto tracing white balance
BATT WARNING : 10% Sets the blinking (alarm) starting level of the remaining amount of battery in ANTON BAUER Inc., battery. 10% : Starts blinking when the remaining amount of battery voltage reaches about 0.67 V. 20% : Starts showing the 20% display when the remaining amount of battery voltage reaches about 1.33 V, and starts blinking at about 1.0 V.
WIDE AWB : ON Widens the adjustment range of auto white balance.
ZEBRA : OFF Sets this item when a VF without the zebra switch is used. A zebra pattern is forcibly displayed on the viewfinder screen regardless of the VF zebra switch setting when this item is set to ON.
* OPERATION MODE 2 *	
TIME CODE DISP : OFF Sets whether to output the time code to the TEST OUT connector and viewfinder screen. VF : Outputs the time code to the viewfinder only. TEST : Outputs the time code to the TEST OUT connector only. BOTH : Outputs the time code to the viewfinder and TEST OUT connector. OFF : Outputs no time code.
* SG ADJ. *	
H BLKG WIDTH : 0 Sets the H blanking width.
V BLKG : 20 H (For NTSC only) Selects the V blanking width. (19 H, 20 H, or 21 H)
REC TALLY : UPPER Selects which LED is made to be lit when REC tally signal is input. UPPER : Only the upper-middle LED BOTH : The upper-middle and lower-middle LEDs

Viewfinder screen (Factory default setting)	Description
* ENC ADJ. *	
BURST START : 0 Adjusts the burst start position.
BURST STOP : 0 Adjusts the burst end position.
R-Y CAR. BAL. : 0 Adjusts the carrier balance of encoder.
B-Y CAR. BAL. : 0 Adjusts the carrier balance of encoder.
SYNC START : 0 Adjusts the start position of the synchronizing signal.
SYNC STOP : 0 Adjusts the end position of the synchronizing signal.
INT FSC FREQ. : 0 Adjusts the fsc frequency.
* DATA RESET *	
USER Resets the data set in the USER mode.
ENGINEER Resets the data set in the USER and ENG modes.
Note	
The adjustment data of the white balance and black balance are cleared in each reset mode. The TEST OUT output is set to ENC. The TEST SAW is canceled and the camera picture is output.	
* MENU SELECT 1 *	
MARKER 1/2 : ON	
MARKER 2/2 : OFF	
VF DISP. 1/2 : ON	
VF DISP. 2/2 : ON	
MASTER GAIN : ON	
SHOT ID : ON	
SHOT DATA DISP. : ON	
SHUTTER SPEED : OFF	
! LED : OFF	
SETUP CARD : ON	
* MENU SELECT 2 *	
VF SETTING : OFF	
LEVEL -1 : OFF	
LEVEL -2 : OFF	
LEVEL -3 : OFF	
LEVEL -4 : OFF	
LEVEL -5 : OFF	
LEVEL -6 : OFF	
LEVEL -7 : OFF	
LEVEL -8 : OFF	
LEVEL -9 : OFF	

Viewfinder screen (Factory default setting)	Description
* MENU SELECT 3 *	Sets whether to display the pages on the left in the USER mode.
W-SHAD._G : OFF	
W-SHAD._R : OFF	
W-SHAD._B : OFF	
B-SHAD._G : OFF	
B-SHAD._R : OFF	
B-SHAD._B : OFF	
FUNCTION 1/2 : OFF	
FUNCTION 2/2 : OFF	
WIDE SCREEN : ON	(DNW-9WS/9WSP/90WS/90WSP only)
* MENU SELECT 4 *	Sets whether to display the pages on the left in the USER mode.
DCC ADJUSTMENT : OFF	
OPERATION MODE 1: OFF	
OPERATION MODE 2: ON	
SG ADJUSTMENT : OFF	
ENC ADJUSTMENT : OFF	
DATA RESET : OFF	
* MEASUREMENT MODE *	Automatically makes various settings required to measure the following specifications (when this item is set to ON).
S/N : OFF S/N
	DETAIL : OFF
	APERTURE : OFF
	CHROMA : OFF
	GAMMA : OFF
	MATRIX : OFF
	FLARE : OFF
MODULATION : OFF MODULATION (modulation degree)
	DETAIL : OFF
	APERTURE : OFF
	GAMMA : OFF
	MATRIX : OFF
	FLARE : OFF
RESOLUTION : OFF RESOLUTION
	MATRIX : OFF
SENSITIVITY : OFF SENSITIVITY
	KNEE : OFF
	WHITE CLIP : OFF
REGISTRATION : OFF REGISTRATION
	DETAIL : OFF
	APERTURE : OFF
MASTER BLACK : 0 Adjusts master black.
TEST OUT : ENC Sets the type of the video signal output from the TEST OUT connector.
	Note
	Same as TEST OUT item of the FUNCTION 1/2 page.
* WHT PRESET *	Used for the manual adjustment when the white balance memory is preset.
R WHT PRESET : 0 Sets the FILTER selector to 1 (3200 K), shoots the light source (pattern box) of the required color temperature, and sets the levels in channels R and B so that the white balance is adjusted.
B WHT PRESET : 0	
	Note
	Check the WHITE BAL switch on the inside panel to PRST.

Setup menu check sheet

<CANCEL>	Yes or No is displayed to indicate whether the value set by the UP/DOWN button can be canceled using the CANCEL/PRST switch.
<PRESET>	Yes or No is displayed to indicate whether the factory default value can be returned using the CANCEL/PRST switch.
<SETUP C>	Yes or No is displayed to indicate whether data can be written in the setup card.
<RM-P9>	M, P, or No is displayed to indicate whether this item can be operated when remote control unit RM-P9 is connected. M (MENU) : Can be operated at the bottom of the RM-P9. P (PANEL) : Can be operated in the front of the RM-P9. No : Cannot be operated by the RM-P9.
<F-SET>	Sets the factory default value.
<C-SET>	Write the setting state of the customer.

PAGE	ITEM	CANCEL	PRESET	SETUP C	RM-P9	F-SET	C-SET
MARKER 1/2	SAFETY ZONE	NO	NO	YES	M	ON	
	SAFETY AREA	NO	NO	YES	M	90%	
	CENTER	NO	NO	YES	M	ON	
	CENTER H	YES	YES	YES	M		
	CENTER V	YES	YES	YES	M		
MARKER 2/2	BOX CURSOR	NO	NO	YES	M	OFF	
	BOX WIDTH	YES	YES	YES	M		
	BOX HEIGHT	YES	YES	YES	M		
	BOX H	YES	YES	YES	M		
	BOX V	YES	YES	YES	M		
VF DISPLAY 1/2	DISP MODE	NO	NO	YES	M	3	
	EXTENDER	NO	NO	YES	M	ON	
	ZOOM	NO	NO	YES	M	ON	
VF DISPLAY 2/2	FILTER	NO	NO	YES	M	ON	
	WHITE	NO	NO	YES	M	ON	
	GAIN	NO	NO	YES	M	ON	
	SHUTTER	NO	NO	YES	M	ON	
	TAPE	NO	NO	YES	M	ON	
	AUDIO	NO	NO	YES	M	ON	
	IRIS	NO	NO	YES	M	ON	
MASTER GAIN	LOW	NO	YES	YES	M	0dB	
	MID	NO	YES	YES	M	9dB	
	HIGH	NO	YES	YES	M	18dB	
	TURBO	NO	YES	YES	M	36dB	
SHOT ID	ID1	YES	YES	YES	M	(Blank)	
	ID2	YES	YES	NO	M	(Blank)	
	ID3	YES	YES	NO	M	(Blank)	
	ID4	YES	YES	NO	M	(Blank)	
SHOT DATA DISP.	DATE	NO	NO	YES	M	OFF	
	TIME	NO	NO	YES	M	OFF	
	MODEL NAME	NO	NO	YES	M	OFF	
	SERIAL NO.	NO	NO	YES	M	OFF	
	CASSTTE NO.	NO	NO	YES	M	OFF	
	SHOT NO.	NO	NO	YES	M	OFF	
	ID SELECT	NO	NO	YES	M	OFF	
SHUTTER SPEED	EVS	NO	NO	YES	P	ON	
	CLS	NO	NO	YES	P	ON	
	1/100 (1/60)	NO	NO	YES	P	ON	
	1/125	NO	NO	YES	P	ON	
	1/250	NO	NO	YES	P	ON	
	1/500	NO	NO	YES	P	ON	
	1/1000	NO	NO	YES	P	ON	
	1/2000	NO	NO	YES	P	ON	

PAGE	ITEM	CANCEL	PRESET	SETUP C	RM-P9	F-SET	C-SET
! LED	MASTER GAIN	NO	NO	YES	M	ON	
	SHUTTER ON	NO	NO	YES	M	ON	
	WHITE PRESET	NO	NO	YES	M	OFF	
	ATW RUN	NO	NO	YES	M	OFF	
	EXTENDER ON	NO	NO	YES	M	ON	
	FILTER 2,3,4	NO	NO	YES	M	OFF	
	A. IRIS OVERRIDE	NO	NO	YES	M	OFF	
SETUP CARD	READ (→ CAM)	—	—	—	M		
	WRITE (→ CARD)	—	—	—	M		
	ID EDIT	—	—	—	M		
	WRITE PROTECT	—	—	—	M	OFF	
FUNCTION 1/2	TEST OUT	NO	YES	NO	M	ENC	
	DETAIL	NO	NO	YES	P	ON	
	APERTURE	NO	NO	YES	M	ON	
	SKIN TONE DTL	NO	NO	YES	M	OFF	
	MATRIX	NO	NO	YES	M	OFF (PAL:ON)	
	GAMMA	NO	NO	YES	M	ON	
	CHROMA	NO	NO	YES	M	ON	
	TEST SAW	NO	NO	YES	P	OFF	
CROSS COLOR FLT	NO	NO	YES	M	OFF (NTSC only)		
FUNCTION 2/2	GENLOCK	NO	NO	YES	M	ON	
	CAM RET.	NO	NO	YES	M	OFF	
	FILTER INH.	NO	NO	YES	NO	OFF	
	FIELD/FRAME	NO	NO	YES	M	FLD	
	A. IRIS OVERRIDE	NO	NO	YES	P	OFF	
	DYNALATITUDE	NO	NO	YES	M	OFF	
WIDE SCREEN	16:9/4:3 MODE	NO	NO	YES	M	16:9	
	VF ASPECT	NO	NO	YES	M	AUTO	
	BOX/4:3 LIMITS	NO	NO	YES	M	BOX	
	"16:9" BARS ID	NO	NO	YES	M	OFF	
	"16:9" VF ID	NO	NO	YES	M	OFF	
VF SETTING	ZEBRA1 DETECT	YES	YES	YES	M	0	
	ZEBRA1 APT.	YES	YES	YES	M	0	
	ZEBRA2 DETECT	YES	YES	YES	M	0	
	ZEBRA SELECT	NO	NO	YES	M	1	
	VF VDTL LEVEL	NO	NO	YES	M	0	

PAGE	ITEM	CANCEL	PRESET	SETUP C	RM-P9	F-SET	C-SET
LEVEL 1	DETAIL LEVEL	YES	YES	YES	P	0	
	V DTL LEVEL	YES	YES	YES	M	0	
	APERTURE LEVEL	YES	YES	YES	M	0	
	KNEE APERTURE	YES	YES	YES	M	0	
	V DTL BLK CLIP	YES	YES	YES	M	0	
	DTL BLK CLIP	YES	YES	YES	M	0	
	LEVEL DEPEND	YES	YES	YES	M	MIN	
	CRISPENING	NO	NO	YES	M	4	
	DTL FREQ	NO	NO	YES	M	4	
LEVEL 2	SUPPRESS LEVEL	YES	YES	YES	M	MIN	
	X	YES	YES	YES	M	0	
	Y	YES	YES	YES	M	0	
	dX	YES	YES	YES	M	0	
	dY	YES	YES	YES	M	0	
	SKIN TONE DTL	NO	NO	YES	M	OFF	
	SKIN TONE IND.	NO	NO	NO	M	OFF	
	SKIN TONE DET.	NO	NO	NO	M	OFF	
LEVEL 3	MASTER BLACK	YES	YES	YES	P	MIN	
	MASTER GAMMA	YES	YES	YES	P	0	
	KNEE POINT 1	YES	YES	YES	P	0	
	KNEE SLOPE 1	YES	YES	YES	M	0	
	KNEE POINT 2	YES	YES	YES	NO	0	
	KNEE SLOPE 2	YES	YES	YES	NO	0	
	KNEE SELECT	NO	NO	YES	NO	1	
	WHITE CLIP	NO	NO	YES	M	ON	
	WHT CLIP LEV.	YES	YES	YES	M	MIN	
LEVEL 4	BURST LEVEL	YES	YES	YES	M	0	
	BURST PHASE	YES	YES	YES	M	0 (PAL only)	
	R-Y	NO	NO	NO	M	ON	
	B-Y	NO	NO	NO	M	ON	
	R-Y LEVEL	YES	YES	YES	M	0 *1	
	B-Y LEVEL	YES	YES	YES	M	0 *1	
	R-Y LEVEL	YES	YES	YES	M	0 *2	
	B-Y LEVEL	YES	YES	YES	M	0 *2	
LEVEL 5	RGB LEVEL	YES	YES	YES	M	0 *1	
	RGB SYNC LEV.	YES	YES	YES	M	0	
	RGB SETUP LEV.	YES	YES	YES	M	0	
	ENC Y LEVEL	YES	YES	YES	M	0 *1	
	ENC SYNC LEV.	YES	YES	YES	M	0	
	ENC SETUP LEV.	YES	YES	YES	M	0	
	RGB LEVEL	YES	YES	YES	M	0 *2	
	ENC Y LEVEL	YES	YES	YES	M	0 *2	

*1:DNW-7, DNW-9WS/9WSP/90WS/90WSP (4:3 mode) only

*2:DNW-90, DNW-9WS/9WSP/90WS/90WSP (16:9 mode) only

PAGE	ITEM	CANCEL	PRESET	SETUP C	RM-P9	F-SET	C-SET
LEVEL 6	R BLACK	YES	YES	YES	P	0	
	G BLACK	YES	YES	YES	M	0	
	B BLACK	YES	YES	YES	P	0	
	R GAMMA	YES	YES	YES	M	0	
	G GAMMA	YES	YES	YES	M	0	
	B GAMMA	YES	YES	YES	M	0	
	BLACK STRETCH	NO	NO	YES	M	2	
	TEST OUT	NO	YES	NO	M	ENC	
LEVEL 7	R FLARE	YES	YES	YES	M	0	
	G FLARE	YES	YES	YES	M	0	
	B FLARE	YES	YES	YES	M	0	
	FLARE	NO	NO	YES	M	ON	
	TEST OUT	NO	NO	NO	M	ENC	
LEVEL 8	MATRIX TABLE	NO	NO	YES	M	A	
	R-G	YES	YES	YES	M	0	
	R-B	YES	YES	YES	M	0	
	G-R	YES	YES	YES	M	0	
	G-B	YES	YES	YES	M	0	
	B-R	YES	YES	YES	M	0	
	B-G	YES	YES	YES	M	0	
	MATRIX	YES	YES	YES	M	OFF (PAL:ON)	
LEVEL 9	H PHASE	YES	YES	YES	M	0	
	SC PHASE	YES	YES	YES	M	0	
	SC 0/180 SELECT	NO	NO	YES	M	0	
	SC-H	YES	YES	YES	M	0	
	IRIS SET	YES	YES	YES	P	0	
	IRIS MODE	YES	YES	YES	M	0	
	IRIS WEIGHT	NO	NO	YES	M	2	
	IRIS SPEED	NO	NO	YES	M	0	
	CLIP HIGH LIGHT	NO	NO	YES	M	OFF	
W-SHAD._G	H SAW	YES	YES	YES	M	0	
	H PARA	YES	YES	YES	M	0	
	V SAW	YES	YES	YES	M	0	
	V PARA	YES	YES	YES	M	0	
	H SAW (EXT)	YES	YES	YES	M	0	
	H PARA (EXT)	YES	YES	YES	M	0	
	V SAW (EXT)	YES	YES	YES	M	0	
	V PARA (EXT)	YES	YES	YES	M	0	
	SHAD COMP.	NO	NO	YES	M	ON	
TEST OUT	NO	YES	NO	M	ENC		

PAGE	ITEM	CANCEL	PRESET	SETUP C	RM-P9	F-SET	C-SET
W-SHAD._R	H SAW	YES	YES	YES	M	0	
	H PARA	YES	YES	YES	M	0	
	V SAW	YES	YES	YES	M	0	
	V PARA	YES	YES	YES	M	0	
	H SAW (EXT)	YES	YES	YES	M	0	
	H PARA (EXT)	YES	YES	YES	M	0	
	V SAW (EXT)	YES	YES	YES	M	0	
	V PARA (EXT)	YES	YES	YES	M	0	
	SHAD COMP.	NO	NO	YES	M	ON	
TEST OUT	NO	YES	NO	M	ENC		
W-SHAD._B	H SAW	YES	YES	YES	M	0	
	H PARA	YES	YES	YES	M	0	
	V SAW	YES	YES	YES	M	0	
	V PARA	YES	YES	YES	M	0	
	H SAW (EXT)	YES	YES	YES	M	0	
	H PARA (EXT)	YES	YES	YES	M	0	
	V SAW (EXT)	YES	YES	YES	M	0	
	V PARA (EXT)	YES	YES	YES	M	0	
	SHAD COMP.	NO	NO	YES	M	ON	
TEST OUT	NO	YES	NO	M	ENC		
B-SHAD._G	H SAW	YES	YES	YES	M	0	
	H PARA	YES	YES	YES	M	0	
	V SAW	YES	YES	YES	M	0	
	V PARA	YES	YES	YES	M	0	
	SHAD COMP.	NO	NO	YES	M	ON	
	TEST OUT	NO	YES	NO	M	ENC	
B-SHAD._R	H SAW	YES	YES	YES	M	0	
	H PARA	YES	YES	YES	M	0	
	V SAW	YES	YES	YES	M	0	
	V PARA	YES	YES	YES	M	0	
	SHAD COMP.	NO	NO	YES	M	ON	
	TEST OUT	NO	YES	NO	M	ENC	
B-SHAD._B	H SAW	YES	YES	YES	M	0	
	H PARA	YES	YES	YES	M	0	
	V SAW	YES	YES	YES	M	0	
	V PARA	YES	YES	YES	M	0	
	SHAD COMP.	NO	NO	YES	M	ON	
	TEST OUT	NO	YES	NO	M	ENC	
DCC ADJ.	D RANGE	NO	NO	YES	M	6	
	POINT	YES	YES	YES	P	0	
	GAIN	YES	YES	YES	M	0	

PAGE	ITEM	CANCEL	PRESET	SETUP C	RM-P9	F-SET	C-SET
OPERATION MODE 1	R-G/B-G SEL	NO	NO	YES	M	OFF	
	GAMMA TABLE	NO	NO	YES	M	A (PAL:B)	
	LOW LIGHT	NO	NO	YES	M	OFF	
	BARS SELECT	NO	NO	YES	M	1 (PAL:2)	
	WHITE B	NO	NO	YES	NO	AWB	
	BATT WARNING	NO	NO	YES	M	10%	
	WIDE AWB	NO	NO	YES	M	ON	
	ZEBRA	NO	NO	YES	M	OFF	
	REC TALLY	NO	NO	YES	M	UPPER	
OPERATION MODE 2	TIME CODE DISP.	NO	NO	YES	M	OFF	
SG ADJ.	H BLKG WIDTH	YES	YES	YES	M	0	
	V BLKG	NO	NO	YES	M	20H (NTSC only)	
ENC ADJ.	BURST START	YES	YES	YES	M	0	
	BURST STOP	YES	YES	YES	M	0	
	R-Y CAR. BAL.	YES	YES	YES	M	0	
	B-Y CAR. BAL.	YES	YES	YES	M	0	
	SYNC START	YES	YES	YES	M	0	
	SYNC STOP	YES	YES	YES	M	0	
	INT FSC FREQ.	YES	YES	YES	M	0	
DATA RESET	USER	—	—	—	NO		
	ENGINEER	—	—	—	NO		
MENU SELECT 1	MARKER 1/2	NO	NO	YES	M	ON	
	MARKER 2/2	NO	NO	YES	M	OFF	
	VF DISP. 1/2	NO	NO	YES	M	ON	
	VF DISP. 2/2	NO	NO	YES	M	ON	
	MASTER GAIN	NO	NO	YES	M	ON	
	SHOT ID	NO	NO	YES	M	ON	
	SHOT DATA DISP.	NO	NO	YES	M	ON	
	SHUTTER SPEED	NO	NO	YES	M	OFF	
	! LED	NO	NO	YES	M	OFF	
	SETUP CARD	NO	NO	YES	M	ON	
MENU SELECT 2	VF SETTING	NO	NO	YES	M	OFF	
	LEVEL 1	NO	NO	YES	M	OFF	
	LEVEL 2	NO	NO	YES	M	OFF	
	LEVEL 3	NO	NO	YES	M	OFF	
	LEVEL 4	NO	NO	YES	M	OFF	
	LEVEL 5	NO	NO	YES	M	OFF	
	LEVEL 6	NO	NO	YES	M	OFF	
	LEVEL 7	NO	NO	YES	M	OFF	
	LEVEL 8	NO	NO	YES	M	OFF	
	LEVEL 9	NO	NO	YES	M	OFF	

PAGE	ITEM	CANCEL	PRESET	SETUP C	RM-P9	F-SET	C-SET
MENU SELECT 3	W-SHAD._G	NO	NO	YES	M	OFF	
	W-SHAD._R	NO	NO	YES	M	OFF	
	W-SHAD._B	NO	NO	YES	M	OFF	
	W-SHAD._G	NO	NO	YES	M	OFF	
	W-SHAD._R	NO	NO	YES	M	OFF	
	W-SHAD._B	NO	NO	YES	M	OFF	
	FUNCTION 1/2	NO	NO	YES	M	OFF	
	FUNCTION 2/2	NO	NO	YES	M	OFF	
	WIDE SCREEN	NO	NO	YES	M	ON (DNW-9WS/9WSP/90WS/ 90WSP only)	
MENU SELECT 4	DCC ADJ.	NO	NO	YES	M	OFF	
	OPERATION MODE 1	NO	NO	YES	M	OFF	
	OPERATION MODE 2	NO	NO	YES	M	ON	
	SG ADJ.	NO	NO	YES	M	OFF	
	ENC ADJ.	NO	NO	YES	M	OFF	
	DATA RESET	NO	NO	YES	M	OFF	
MEASUREMENT MODE	S/N	—	—	—	NO	OFF	
	MODULATION	—	—	—	NO	OFF	
	RESOLUTION	—	—	—	NO	OFF	
	SENSITIVITY	—	—	—	NO	OFF	
	REGISTRATION	—	—	—	NO	OFF	
	MASTER BLACK	—	—	—	NO	0	
	TEST OUT	NO	YES	NO	M	ENC	
WHT PRESET	R WHT PRESET	YES	YES	YES	NO	0	
	B WHT PRESET	YES	YES	YES	NO	0	

3-2. DIAG Menu

The DIAG menu is used for the maintenance menu setting and troubleshooting of the DNV-5.

Notes

- Use the DIAG menu in the state in which the tape transport stopped.
- Do not execute the DIAG menu when remote control RM-P9 is connected. The self-diagnosis function and remote control function are not normally activated when the self-diagnosis is executed.

Operation

1. DIAG menu activation
Push the DIAG switch on the inside panel with the tip of a clip so as to display the DIAG menu on the LCD display.
2. PAGE selection
Press the ADVANCE button and select the PAGE.
To increment the menu number, press the ADVANCE button.
To decrement the menu number, press the ADVANCE and HOLD buttons simultaneously.
After selection, Press the SHIFT button.
Select the PAGE repeatedly until the desired ITEM is found.
3. ITEM selection
Press the ADVANCE button and select the ITEM.
After selection, press the SHIFT button.
4. ITEM setting
Press the ADVANCE button to change the set value.
After change, press the SHIFT button.
5. DIAG menu termination
Press the DIAG switch.

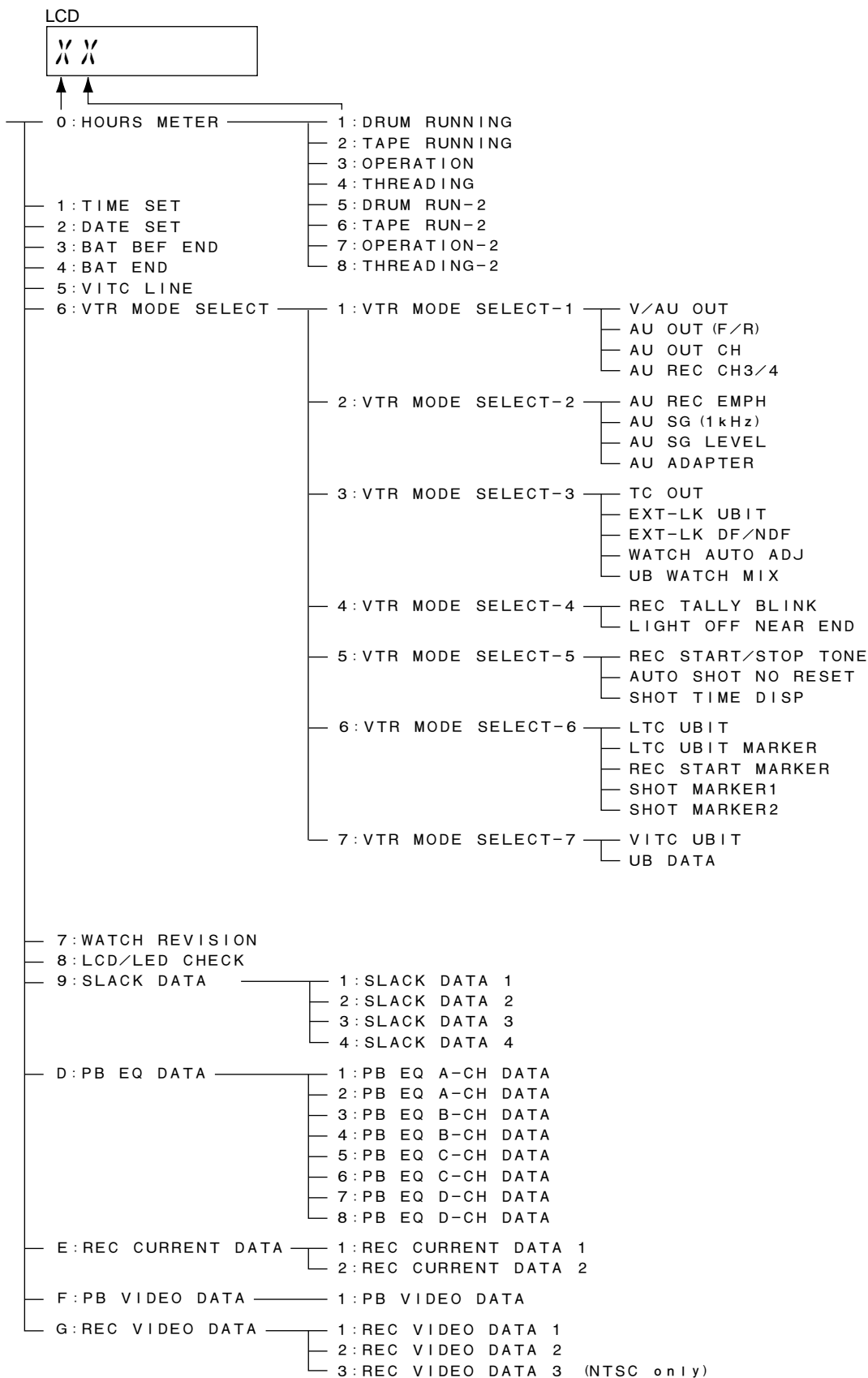

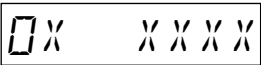
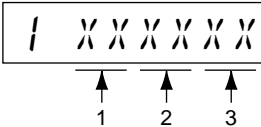
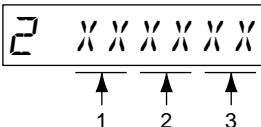
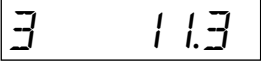
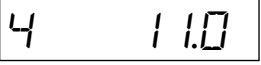
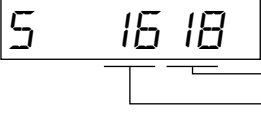
LCD Display (factory setting)	Description
<p>DIAG 0</p> <p>HOURS METER</p>  <p>1. DRUM RUNNING Total drum rotating hours</p> <p>2. TAPE RUNNING Total tape running hours</p> <p>3. OPERATION Total power-on time</p> <p>4. THREADING Total number of threading</p> <p>5. DRUM RUN-2 Drum rotating hour (Customer-resetable)</p> <p>6. TAPE RUN-2 Tape running hour (Customer-resetable)</p> <p>7. OPERATION-2 Power-on time (Customer-resetable)</p> <p>8. THREADING-2 The number of threading (Customer-resetable)</p>	<p>The contents below are displayed. (For more details, refer to 6-3-1, "Hours Meter".)</p>
<p>DIAG 1</p> <p>TIME</p>  <p>1. Sets the hour.</p> <p>2. Sets the minute.</p> <p>3. Sets the second.</p>	<p>Internal timer setting.</p>
<p>DIAG 2</p> <p>DATE</p> 	<p>Internal timer date setting.</p> <p>1. Sets the month (for NTSC) /day (for PAL).</p> <p>2. Sets the day (for NTSC) /month (for PAL).</p> <p>3. Sets the year.</p>
<p>DIAG 3</p> <p>BATTERY VOLTAGE</p> <p>BEFORE END</p> 	<p>Displays and sets the battery before end voltage. (For the setting, refer to the Operation Manual.)</p> <p>Battery before end voltage setting</p> <p>11.0 to 13.0 V (in units of 0.1 V)</p> <p>"0" is displayed on the LCD when the setting is OK.</p> <p>"E" is displayed on the LCD when the setting is NG.</p>
<p>DIAG 4</p> <p>BATTERY VOLTAGE</p> <p>END</p> 	<p>Displays and sets the battery end voltage. (For the setting, refer to the Operation Manual.)</p> <p>Battery end voltage setting</p> <p>10.5 to 11.5 V (in units of 0.1 V)</p> <p>"0" is displayed on the LCD when the setting is OK.</p> <p>"E" is displayed on the LCD when the setting is NG.</p>
<p>DIAG 5</p> <p>VITC INSERT LINE</p> 	<p>Displays and sets the VITC insertion line.</p> <p>12 to 19 lines (For NTSC)</p> <p>9 to 22 lines (For PAL)</p>

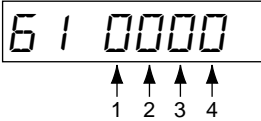
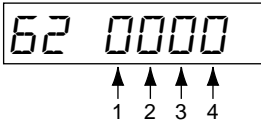
LCD Display (factory setting)	Description
<p>DIAG 6-1</p> <p>VTR MODE SEL-1</p> 	<ol style="list-style-type: none"> 1. V/AU OUT : Sets the video and audio output. <ul style="list-style-type: none"> 0 : Outputs the PB/EE signal. 1 : Outputs the EE signal. 2. AU OUT (F/R) : Sets the audio output during FF/REW. (Valid when V/AU OUT is set to 0.) <ul style="list-style-type: none"> 0 : Outputs the EE signal. 1 : Outputs no signal. 3. AU OUT CH : Sets the audio output channel. <ul style="list-style-type: none"> 0 : CH1/2 1 : CH3/4 4. AU REC CH3/4 : Selects the source during recording in CH3/4. (Valid when no camera adapter (CA-701) is connected or when AU ADAPTER ENABLE is disabled.) <ul style="list-style-type: none"> 0 : Front MIC input (CH3) and wireless receiver input (CH4). 1 : Records the same signal as in CH1/2. 2 : Not use CH3/4.
<p>DIAG 6-2</p> <p>VTR MODE SEL-2</p> 	<ol style="list-style-type: none"> 1. AU REC EMPH : Sets the audio emphasis (during recording) to ON or OFF. <ul style="list-style-type: none"> 0 : OFF 1 : ON 2. AU SG (1 kHz) : Sets whether to generate a 1 kHz test signal when a color-bar signal is generated from the internal signal generator. <ul style="list-style-type: none"> 0 : Not generates. 1 : Generates when the CH1 AUDIO SELECT switch on the inside panel is set to AUTO. 2 : Generates. 3. AU SG LEVEL : Sets the level of a 1 kHz test signal. <ul style="list-style-type: none"> 0 : -20 dBu (600 Ω) 1 : -18 dBu (600 Ω) 2 : -16 dBu (600 Ω) 4. AU ADAPTER : Sets whether to connect the camera adapter (CA-701). <ul style="list-style-type: none"> 0 : Connects. 1 : Not connect.

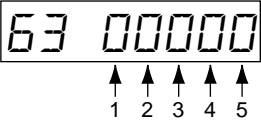
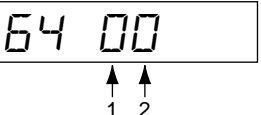
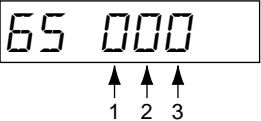
LCD Display (factory setting)	Description
<p>DIAG 6-3</p> <p>VTR MODE SEL-3</p> 	<ol style="list-style-type: none"> 1. TC OUT : Sets the time code output. <ul style="list-style-type: none"> 0 : Outputs PB/TCG. 1 : Outputs TCG. 2. EXT-LK UBIT : Sets the LTC UB set value when the time code is locked externally. <ul style="list-style-type: none"> 0 : Internally set value 1 : External LTC value 3. EXT-LK DF/NDF : Sets the DF/NDF (NTSC only). <ul style="list-style-type: none"> 0 : Conforms to the DF/NDF switch setting on the inside panel. 1 : Conforms to the external LTC setting. 4. WATCH AUTO ADJ : Sets the internal timer automatic time correction (according to the user's bit of the unit connected to TC OUT). <ul style="list-style-type: none"> 0 : Corrects. 1 : Not correct. 5. UB WATCH MIX : Sets whether to output the time of an internal timer to the LTC UB. <ul style="list-style-type: none"> 0 : Not output. 1 : Outputs.
<p>DIAG 6-4</p> <p>VTR MODE SEL-4</p> 	<ol style="list-style-type: none"> 1. REC TALLY BLINK : Sets whether the TALLY lamp blinks during battery before end and tape before end. <ul style="list-style-type: none"> 0 : Blinks. 1 : Lights. 2. LIGHT OFF NEAR END : Sets whether to turn off the light during battery before end. <ul style="list-style-type: none"> 0 : Turns off forcibly. 1 : Not turn off.
<p>DIAG 6-5</p> <p>VTR MODE SEL-5</p> 	<ol style="list-style-type: none"> 1. REC START/STOP TONE : Sets whether to output a sound when the REC START/ STOP button is pressed. <ul style="list-style-type: none"> 0 : Outputs no sound. 1 : Outputs a sound. 2. SHOT NO. RESET : Sets whether to reset the shot number automatically during tape-threading. <ul style="list-style-type: none"> 0 : Resets automatically. 1 : Not reset. 3. SHOT TIME DISP : Sets the format of the time displayed on the LCD. <ul style="list-style-type: none"> 0 : Month Day : Hour Minute 1 : Day Month : Hour Minute 2 : Day : Hour Minute Second

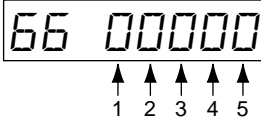
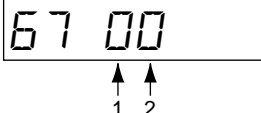
LCD Display (factory setting)	Description
<p>DIAG 6-6</p> <p>VTR MODE SEL-6</p> 	<ol style="list-style-type: none"> 1. LTC UBIT : Sets the data recorded in the user bits of LTC. <ul style="list-style-type: none"> 0 : Fixed data (Conventional-type user bits) 1 : Time of internal timer (in real time) 2 : Shot data 2. LTC UB-MARKER : Sets whether to write the mark below in the user bits of LTC. <ul style="list-style-type: none"> REC start mark Shot mark 1 Shot mark 2 0 : Conform to the menu setting below. 1 : Writes all marks. 2 : Writes nothing. 3. REC START MARKER (Valid when the LTC UB-maker is set to SW.) <ul style="list-style-type: none"> 0 : Writes. 1 : Not write. 4. SHOT MARKER 1 (Valid when the LTC UB-marker is set to SW.) <ul style="list-style-type: none"> 0 : Writes. 1 : Not write. 5. SHOT MARKER 2 (Valid when the LTC UB-marker is set to SW.) <ul style="list-style-type: none"> 0 : Writes. 1 : Not write.
<p>DIAG 6-7</p> <p>VTR MODE SEL-7</p> 	<ol style="list-style-type: none"> 1. VITC UBIT : Sets the data recorded in the user bits of VITC. <ul style="list-style-type: none"> 0 : Fixed data (Conventional-type user bits) 1 : Time of internal timer (in real time) 2 : Shot data 2. SHOT DATA : Sets the data length of the VITC shot data. <ul style="list-style-type: none"> 0 : Record data of date, time, model ID, serial No., cassette No., shot No. 1 : Record data of date, time, model ID, serial No., cassette No., shot No., shot ID 1 to 4.

LCD Display (factory setting)	Description			
<p>DIAG 7</p> <p>WATCH REVISION</p> <div style="border: 1px solid black; padding: 5px; display: inline-block;"> 7 XXX </div>	<p>Sets the corrected value of an internal timer (the number of frames a day).</p>			
<p>DIAG 8</p> <p>LCD/LAMP CHECK</p> <div style="border: 1px solid black; padding: 5px; display: inline-block;"> 8 </div>	<p>Sets the LCD light check.</p> <p>All the lamps are turned on or off every time the SHIFT button is pressed.</p>			
<p>DIAG 9</p> <div style="border: 1px solid black; padding: 5px; display: inline-block;"> 9x XXXX </div>	<p>STATE CODE</p> <p>TROUBLE CODE</p> <table style="width: 100%; border-collapse: collapse;"> <tr> <td style="width: 15%; vertical-align: top;"> <p>1. SLACK DATA 1</p> <p>2. SLACK DATA 2</p> <p>3. SLACK DATA 3</p> <p>4. SLACK DATA 4</p> </td> <td style="width: 10%; vertical-align: top;"> <p>.....</p> <p>.....</p> <p>.....</p> <p>.....</p> </td> <td style="width: 75%; vertical-align: top;"> <p>Slack trouble code 1 (latest)</p> <p>Slack state code 1 (latest)</p> <p>Slack trouble code 2</p> <p>Slack state code 2</p> <p>Slack trouble code 3</p> <p>Slack state code 3</p> <p>Slack trouble code 4</p> <p>Slack state code 4</p> </td> </tr> </table> <ul style="list-style-type: none"> • Contents of slack trouble code <ul style="list-style-type: none"> 10 : Abnormal drum drive voltage 11 : No drum FG output 12 : No drum PG output 20 : Abnormal capstan drive voltage 21 : No capstan FG-A output 22 : No capstan FG-B output 23 : Abnormal forward/reverse rotation of capstan 24 : Abnormal capstan speed (high-speed) 32 : No S reel FG output 42 : No T reel FG output 61 : Time over the forward rotation time of function cam 62 : Time over the reverse rotation time of function cam 63 : Time over the tape top sensor 64 : Time over the full top sensor 65 : Time over the end sensor time 70 : Servo NVRAM checksum error 71 : Communication error between servo CPUs • Contents of slack state code <ul style="list-style-type: none"> 00 : Power-on initialization 1x : No cassette and standby state 2x : Record 3x : Stop 4x : FF/REW 5x : Playback 6x : REC PAUSE 7x : REC REVIEW 8x : Threading/unthreading 	<p>1. SLACK DATA 1</p> <p>2. SLACK DATA 2</p> <p>3. SLACK DATA 3</p> <p>4. SLACK DATA 4</p>	<p>.....</p> <p>.....</p> <p>.....</p> <p>.....</p>	<p>Slack trouble code 1 (latest)</p> <p>Slack state code 1 (latest)</p> <p>Slack trouble code 2</p> <p>Slack state code 2</p> <p>Slack trouble code 3</p> <p>Slack state code 3</p> <p>Slack trouble code 4</p> <p>Slack state code 4</p>
<p>1. SLACK DATA 1</p> <p>2. SLACK DATA 2</p> <p>3. SLACK DATA 3</p> <p>4. SLACK DATA 4</p>	<p>.....</p> <p>.....</p> <p>.....</p> <p>.....</p>	<p>Slack trouble code 1 (latest)</p> <p>Slack state code 1 (latest)</p> <p>Slack trouble code 2</p> <p>Slack state code 2</p> <p>Slack trouble code 3</p> <p>Slack state code 3</p> <p>Slack trouble code 4</p> <p>Slack state code 4</p>		

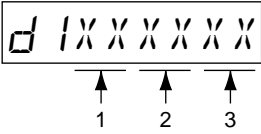
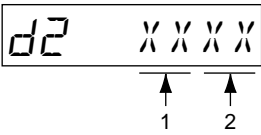
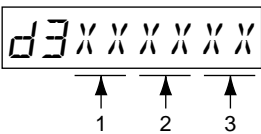
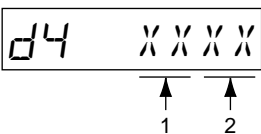
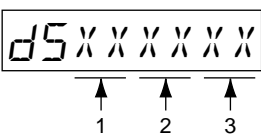
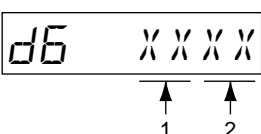
LCD Display (factory setting)	Description
<p>DIAG D-1</p> <p>PG EQ ADJ DATA-1</p> 	<p>Displays the equalizer adjustment data (A-CH).</p> <ol style="list-style-type: none"> 1. A-CH FREQ 2. A-CH PHASE 3. A-CH GAIN
<p>DIAG D-2</p> <p>PG EQ ADJ DATA-2</p> 	<p>Displays the equalizer adjustment data (A-CH).</p> <ol style="list-style-type: none"> 1. A-CH ENV 2. A-CH PLL
<p>DIAG D-3</p> <p>PG EQ ADJ DATA-3</p> 	<p>Displays the equalizer adjustment data (B-CH).</p> <ol style="list-style-type: none"> 1. B-CH FREQ 2. B-CH PHASE 3. B-CH GAIN
<p>DIAG D-4</p> <p>PG EQ ADJ DATA-4</p> 	<p>Displays the equalizer adjustment data (B-CH).</p> <ol style="list-style-type: none"> 1. B-CH ENV 2. B-CH PLL
<p>DIAG D-5</p> <p>PG EQ ADJ DATA-5</p> 	<p>Displays the equalizer adjustment data (C-CH).</p> <ol style="list-style-type: none"> 1. C-CH FREQ 2. C-CH PHASE 3. C-CH GAIN
<p>DIAG D-6</p> <p>PG EQ ADJ DATA-6</p> 	<p>Displays the equalizer adjustment data (C-CH).</p> <ol style="list-style-type: none"> 1. C-CH ENV 2. C-CH PLL

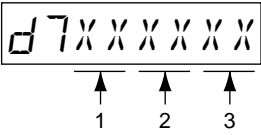
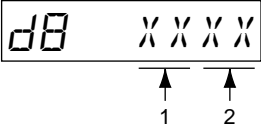
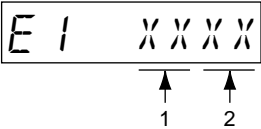
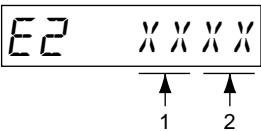
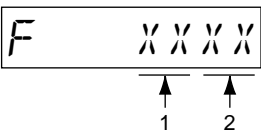
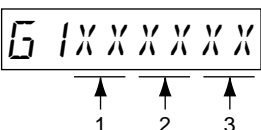
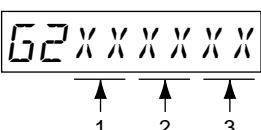
LCD Display (factory setting)	Description
<p>DIAG D-7</p> <p>PG EQ ADJ DATA-7</p> 	<p>Displays the equalizer adjustment data (D-CH).</p> <ol style="list-style-type: none"> 1. D-CH FREQ 2. D-CH PHASE 3. D-CH GAIN
<p>DIAG D-8</p> <p>PG EQ ADJ DATA-8</p> 	<p>Displays the equalizer adjustment data (D-CH).</p> <ol style="list-style-type: none"> 1. D-CH ENV 2. D-CH PLL
<p>DIAG E-1</p> <p>REC CURRENT DATA-1</p> 	<p>Displays the REC current adjustment data.</p> <ol style="list-style-type: none"> 1. A-CH 2. B-CH
<p>DIAG E-2</p> <p>REC CURRENT DATA-2</p> 	<p>Displays the REC current adjustment data.</p> <ol style="list-style-type: none"> 1. C-CH 2. D-CH
<p>DIAG F</p> <p>PB VIDEO ADJ DATA</p> 	<p>Displays the PB video adjustment data.</p> <ol style="list-style-type: none"> 1. VIDEO LEVEL 2. INT BURST FRQ
<p>DIAG G-1</p> <p>REC VIDEO ADJ DATA-1</p> 	<p>Displays the REC video adjustment data.</p> <ol style="list-style-type: none"> 1. Not used 2. R-Y DELAY 3. B-Y DELAY
<p>DIAG G-2</p> <p>REC VIDEO ADJ DATA-1</p> 	<p>Displays the REC video adjustment data.</p> <ol style="list-style-type: none"> 1. Y LEVEL 2. R-Y LEVEL 3. B-Y LEVEL

Section 4

Block Diagram and Circuit Description

Circuit Description

(1) Camera process system (DCP-1 and ES-11 boards)

- DCP-1 board

The DCP-1 board consists of the following blocks:

- (1) Receiver of R/G/B signals from the CCD block, A/D converters for R/G/B signals, Digital processor to convert to the digital component signals, and D/A converter so as to output the Y/R-Y/B-Y/VF signals to the ES-11 board.
- (2) Driver block which adds the character data to the composite signal supplied from the ES-11 board, and outputs the added signal.
- (3) Rate converter
- (4) Signal processor for viewfinder

The analog R/G/B signals which are input from the CCD block are passed through the respective pre-filters having the corresponding sampling frequencies (WIDE/NORMAL), then are converted by the A/D converter to the 10-bit digital R/G/B signals of 14 MHz (NORMAL) or 18 MHz (WIDE) rate respectively.

The digital R/G/B signals after A/D conversion are input to the pre-process IC. This IC detect the average value and peak value of the video signals detected which are required by the AUTO operation system of the camera such as auto black balance, auto white balance and auto iris and so on.

The pre-process IC outputs the black and white shading correction signals (G BSH, R BSH, B BSH/G WSH, R WSH and B WSH), feed-back clamp control signal (G FB, R FB and B FB) and TEST SAW signal to the CCD block.

The digital G and R signals output from the pre-process IC are passing through the 1H delay lines to generates the V details, and input to the processor IC. But digital B signal output from the pre-process IC is input the processor IC directly.

In the processor IC, the digital R/G/B signals are up-converted to 28 MHz (NORMAL) or 36 MHz (WIDE) signal respectively, the matrix and the detail signals are added, the flare compensation, pedestal control, gamma correction, knee correction and white clip are applied, then converted to the digital component signals (Y, R-Y and B-Y).

The processor IC has the function of the output signal switch circuit which switches between the built-in color signal and the main line signal. The processor IC also has the Y, R/G/B video outputs circuit for viewfinder. The output signals of the processor IC are D/A converted and send to the VF or TEST OUT terminal. The viewfinder output circuit has the signal selector function which enables monitoring the video signal supplied to the GENLOCK IN connector or the RET video signal when a CCU is connected, using the monitor select IC.

The digital component signal output from the processor IC is passed through the CN-1193 board ^{*1}, and input to the rate converter and D/A converter. The digital component signal is rate-converted to 27 MHz by rate converter, and output to the DVP-1 board. The other digital component signal is D/A converted, and resultant analog component signals (Y, R-Y, B-Y) are output to ES-11 board.

The average value and peak value of the video signal which are detected in the pre-process IC are sent to the camera CPU and the control CPU via I/O expander through the 4-bit LSI data bus.

After processing the detected values by the camera CPU, the control data is sent to the processor IC and VA-167 board in CCD block through data bus and SAD (CCD) signal.

The control CPU performs the various controls of the camera block in accordance with the commands stored in the ROM. The control CPU decodes the variable control data which are detected in pre-process IC, function switch command and analog data, and then output the various control signals.

The control CPU writes the status information and the self-diagnostics information to the character generator and outputs these data as the character data.

Connection with the external equipment such as RM-P9 (optional) and VA-DN1 (optional) is made possible by the transmitter/receiver IC.

- ES-11 board

The ES-11 board consists of the two major circuit: one is the circuit which generated the composite signal from the D/A converted analog component signal supplied from the DCP-1 board, and the other circuit which is the sync generator circuit generating the various sync signals for comcorder.

Almost adjustments are performed by electronic control using setup menu.

The ES-11 board has the sync separator IC and PLL IC so that the camera block is sync-locked to the external input video signal supplied from the GENLOCK IN terminal.

*1: In DNW-9WS/9WSP/90WS/90WSP, this circuit operated as follows:

In the 4:3 mode, the digital component signal from the processor IC is stretched by down-converting from 18 MHz to 13.5 MHz, then is re-sampled by 18 MHz and is output.

(2) Digital signal system

(DVP-1 (1/2) board, DVP-2 board, and drum assembly)

- Signal processing during recording

The parallel video data supplied from the camera is compressed to a data rate of approximately 1/10 using an SX encoder after addition of the VITC signal.

The compressed video data is input to the ECC encoder where an outer ECC is added to the video data and track-interleaved.

The serial audio data (A/D DATA 1/2 and 3/4) supplied from the TC-80 board is also input to the ECC encoder where an outer ECC is added and the audio data is field-shuffled. The video data and audio data are multiplexed and inner-ECC-encoded by the ECC encoder.

The resultant data is then sent to the drum as the four-channel parallel record data.

The Betacam SX Camcorder records the video and audio signals on magnetic tape in a Betacam SX format.

The Betacam SX Camcorder uses the four rotary heads which have an azimuth angle in the opposite direction to each other, and are paired. Every rotation of the drum records the four helical tracks. Every five rotations of the drum i.e., the twenty helical tracks record the four frame data.

* The Betacam format of the PAL system records the two frame data with three rotations, i.e., twelve helical tracks.

- Signal processing during playback

The four-channel parallel PB data sent from the drum is inner-corrected by the inner ECC decoder.

The parallel PB data is then deinterleaved and sent to the outer ECC decoder where the video data is outer-corrected and sent to the SX decoder.

The SX decoder perform the bit rate reduction decoding of the playback video data so that the original data rate is restored.

The errors that cannot be corrected by the ECC decoder are sent to the memory where separate error correction is performed. This data feedback to the camera block.

Audio data is outer-corrected, error-corrected, then converted of its clock rate using FIFO memory. The audio data is sent to the audio data processor in the form of two-channel serial audio data (CONFI AU 1/2 and 3/4).

The NTSC Betacam SX system is equipped with a five-field sequence generator which controls the five-field sequence of audio playback data.

The digital data processing in each IC is performed under communication with the system control CPU.

(3) Audio system

(AXM-14 board (1/2), CNB-1 board (1/2), TC-80 board (1/2), RX-26 board, MA-68 board and AIF-8 board)

The audio system of the Betacam SX recorder has the configuration of the four input channels and the two output channels.

The CH-1 and CH-2 have the "AUDIO IN" switches which select their input signals from either the LINE/MIC input (rear input) signals coming from the XLR connectors on the rear panel, or the camera MIC input signal (front MIC input: CH-3) coming from the camera, or the wireless audio input signal (CH-4) coming from the slot-in wireless receiver, to be recorded on tape.

The selected input signal is A/D converted and sent to the audio data processor as the AU A/D data (1/2 and 3/4). The output signal from the audio data processor is D/A converted. The CH-1 and CH-2 signals are output from the 5-pin XLR connector.

The earphones and internal speakers have the "MONITOR" switch which selects either CH-1, MIX, or CH-2 signal to be output the earphones and internal speakers.

(4) System control

(DVP-1 board (2/2), TC-80 board (2/2), KY-293 board, HN-224 board (1/2), and AXM-14 board (2/2))

Among the captioned circuit boards of the system control block, the DVP-1 board controls its peripheral boards and the entire system, while the TC-80 board controls the system unique to the machine such as time code, display, and key panel.

- **DVP-1 board (2/2)**

The DVP-1 board (2/2) has the system control CPU that is the center of the system control. A 16-bit CPU operating on a clock speed of 20 MHz, is used for the system control CPU because it handles large volumes of data such as communication with digital processors. Regarding communication, the interface of the DVP-1 board is established after the parallel bus is level-shifted (from 5V → 3.3 V) because the parallel bus interface system such as digital processor ICs, operates on 3.3 V. The serial interface system can be interfaced directly with the SIO of the CPU. However, because the CPU must establish serial communication with the SERVO MPU and TC MPU in addition to the SIO. The SIO is shared and is switched to either SCI (DPR) or SCI (SV) or SCI (TC) by the SCI selector.

For the serial communication with the CT MPU, another SIO is used for interface because the CT MPU uses the different synchronization system against VTR. An I/O expander covers an insufficient I/O port.

- **TC-80 board (2/2)**

The TC MPU on the TC-80 board (2/2) controls TC IC (LTC reader and generator) while communicating with the system control CPU in serial communication.

The TC MPU also controls the LCD module, key matrix, and character generator via the I/O expander.

A backup power supply using a lithium battery is provided to back up the generators and real-time data.

**(5) Servo control block
(MDC-5 board and HN-224 board (2/2))**

- MDC-5 board

The MDC-5 board has the two MPUs. MPU1 controls the mode control and capstan servo system while communicating with the system control CPU in serial communication. MPU2 controls the drum servo system while interfacing with MPU1.

The drum motor and capstan motor are controlled by the PWM switching drive of the feedback servo between FG and PG pulses and between FG and CTL pulses, respectively. The threading motor is controlled by a bidirectional motor driver.

**(6) Power supply system
(CNB-1 board (2/2), RE-118 board, and RE-119 board)**

- CNB-1 board (2/2)

The input DC 12 V from the battery pack or DC IN connector is input to the CNB-1 board (2/2) where the input 12 V passes through a breaker and turned on or off by the POWER switch and is output as an UNREG 12 V. This output voltage is sent not only to the camera and VTR blocks but also to the RE-119 board.

- RE-118 and RE-119 boards

The RE-118 and RE-119 boards make up a DC-DC converter. The UNREG 12 V supplied from the CNB-1 board (2/2) is converted to the various output DC voltages which are sent to the camera and VTR.

The converter system uses an highly efficient synchronous type PWM switching regulator system.

The PWM switching regulator is equipped with a short-circuit protection circuit which turns off all outputs when any of the output power is shorted to GND. The PWM switching regulator is also equipped with the cut-off circuit which shuts down the output power when the input voltage is decreased below the guaranteed operating voltage.

Block Diagram

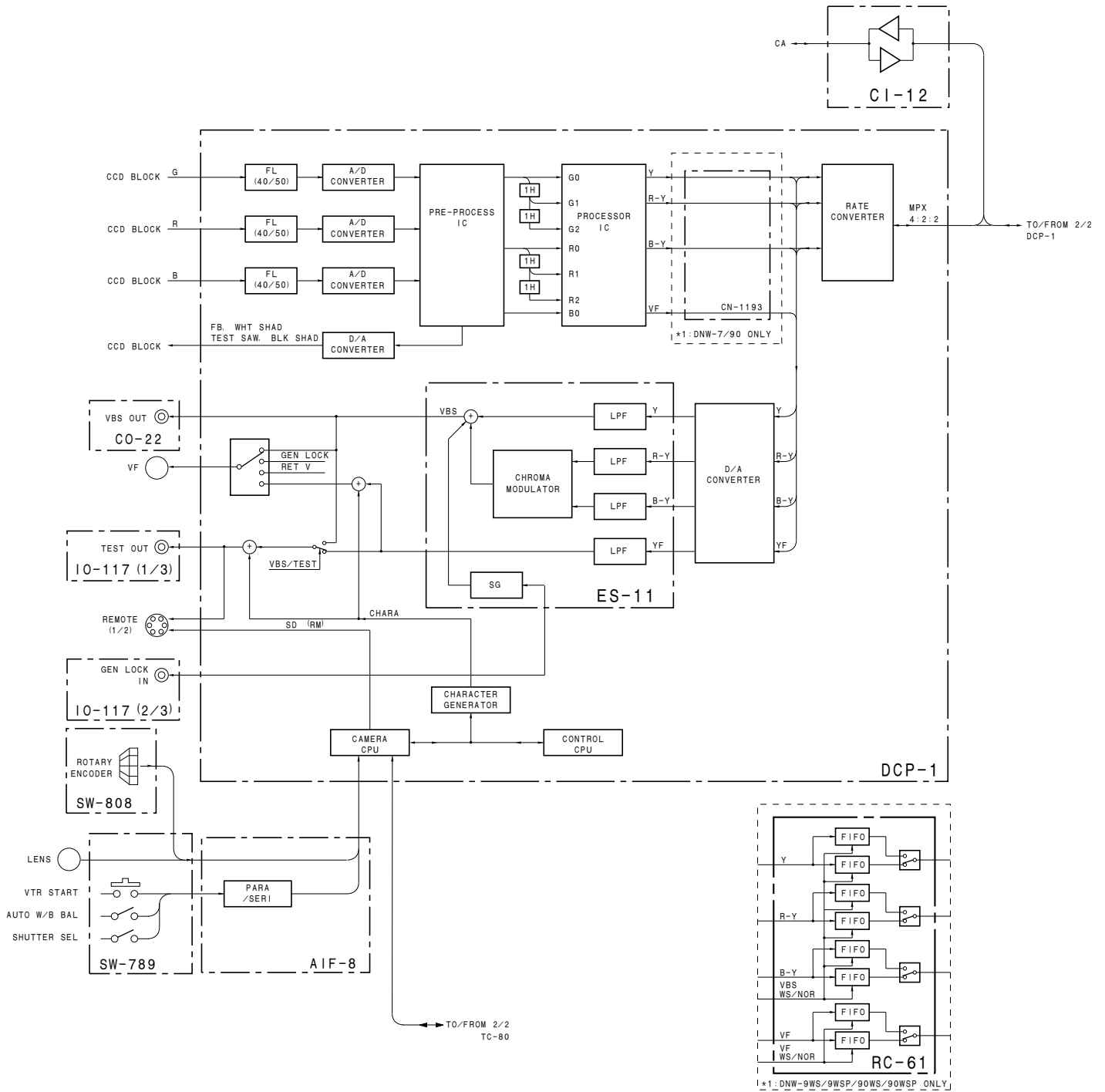

OVERALL (1/2)

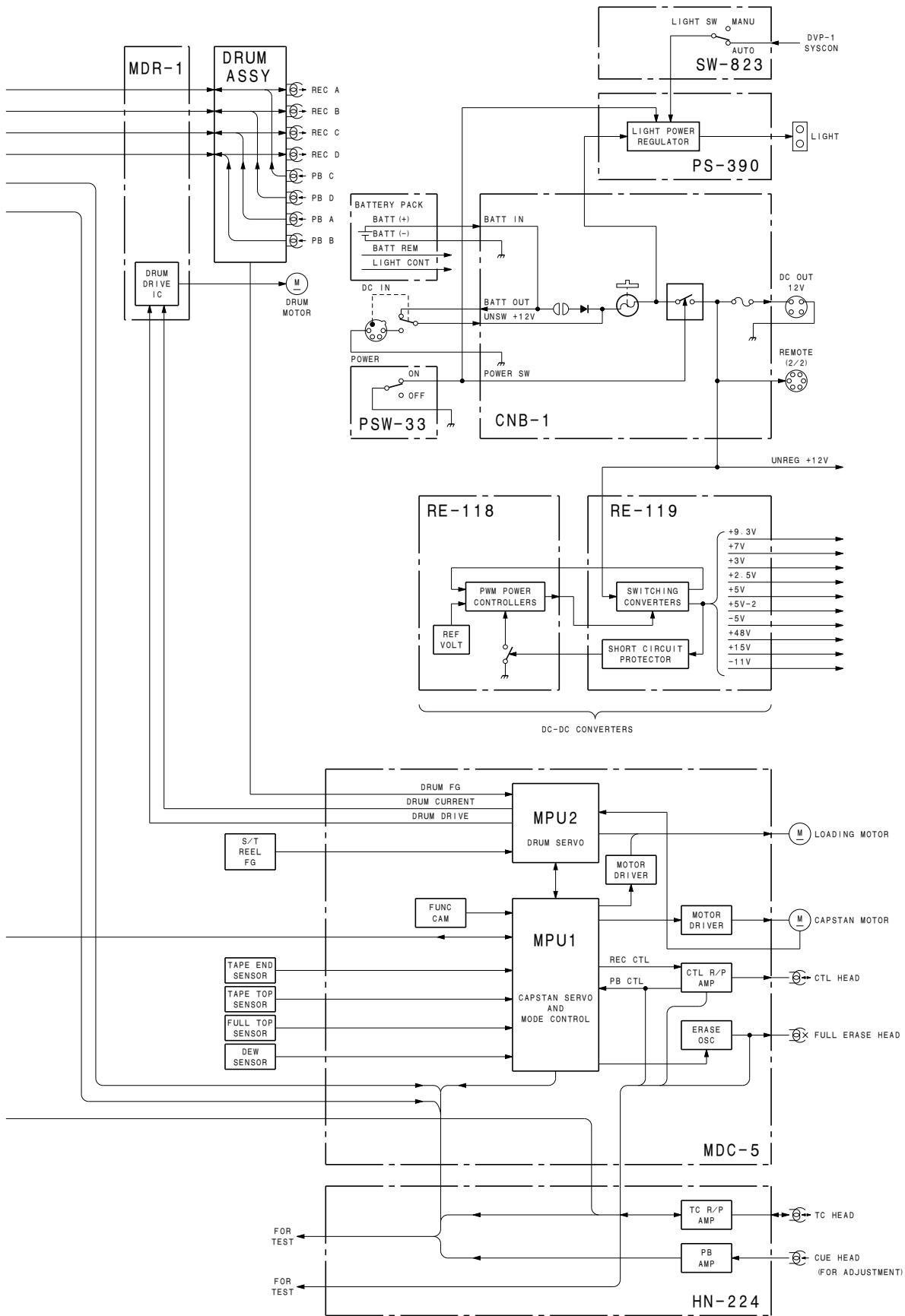

OVERALL (2/2)

Section 5

Electrical Alignment

5-1. General Information for Electrical Adjustment

5-1-1. Note for Adjustment

Before adjustment, set the main POWER switch to on and the VTR switch to SAVE, then warm up the camera for about 10 minutes.

Be sure to set the main POWER switch of the external DC power supply to off before extracting the plug-in board.

Indication at the top right on the viewfinder screen.

In adjustment on the setting menu, a bar sometimes appears at the top right on the viewfinder screen. The bar indicates the current setting state and adjustable range for the selected item.

5-1-2. Equipment/Fixtures

- Oscilloscope
Tektronix 2465 or equivalent
- Waveform monitor/Vectorscope
Tektronix 1750/1751 or equivalent
- Monitor
Sony BVM-1410/1411P or equivalent
- Pattern box (PTB-500, 90 - 240 Vac)
J-6029-140-B
- Gray scale chart (4:3)
J-6026-130-A

5-1-3. Initial Setting for Switches

Execute the camera system alignment using the ENG mode in the SETUP menu. When the setting mode is changed ENG, set switches as follows.

1. Set the POWER switch to off.
2. S4-1 (DCP-1 board) → OFF
3. S1 (DCP-1 board) → OFF
4. While holding down the rotary encoder, turn the power ON

Note

When adjustment is performed in the ENG mode, the values of items adjusted in the USER mode become 0.

Initial Setting

Before performing adjustment, set switches as follows. If the setting of the GAIN switch is changed from the factory set value, reset it to its original value by referring to the operation manual.

Inside panel :

- VTR SAVE/STBY switch → STBY
- GAIN switch → L (0 dB)
- OUTPUT/DCC switch → CAM/OFF
- MENU switch → OFF
- WHITE BAL switch → PRST

Front panel :

- SHUTTER switch → OFF
- Filter selector → 1

Lens :

- LENS → MANU
- IRIS → (CLOSE)

SETUP menu :

- MASTER GAIN
 - LOW → 0 dB
 - MID → 9 dB
 - HIGH → 18 dB
- FUNCTION 1/2
 - TEST OUT → ENC
 - DATAIL → ON
 - SKIN TONE DTL → OFF
 - MATRIX → OFF
 - GAMMA → ON
 - CHROMA → ON
 - TEST SAW → OFF
- FUNCTION 2/2
 - GENLOCK → ON
 - CAM RET → OFF
 - FILTER INH → ON
- LEVEL 3
 - KNEE SELECT → ON
 - WHITE CLIP → ON
- LEVEL 4
 - R-Y → ON
 - B-Y → ON

5-2. ENC Level Adjustment

Preparation

- OUTPUT/DCC switch (inside panel) → BARS
- On the setting menu, set as follows.
 PAGE : LEVEL 7
 ITEM : TEST OUT → ENC

Adjustment procedure

Equipment : Waveform monitor
 Test point : VIDEO OUT connector

1. On the setting menu, adjust as follows.
 PAGE : LEVEL 5
 ITEM : ENC SYNC LEVEL
 Spec. : A = 40 ± 1 IRE (NTSC)
 A = 300 ± 7 mV (PAL)

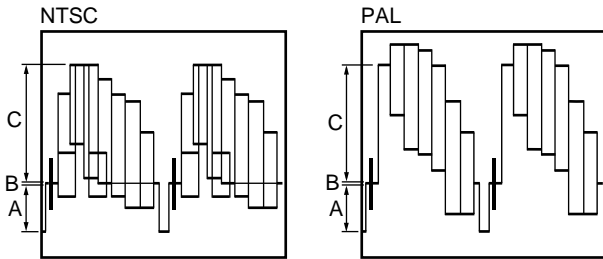

2. On the setting menu, adjust as follows.
 PAGE : LEVEL 5
 ITEM : ENC SETUP LEVEL
 Spec. : B = 7.5 ± 0.5 IRE (NTSC)
 B = 0 ± 3 mV (PAL)

3. On the setting menu, adjust as follows.
 PAGE : LEVEL 5
 ITEM : ENC Y LEVEL
 Spec. : C = 100 ± 2 IRE (NTSC)
 C = 700 ± 14 mV (PAL)

5-3. TEST OUT Adjustment

Preparation

- OUTPUT/DCC switch (inside panel) → BARS
- On the setting menu, set as follows.
 PAGE : LEVEL 7
 ITEM : TEST OUT → R, G or B

Adjustment procedure

Test point : TEST OUT connector

1. On the setting menu, adjust as follows.
 PAGE : LEVEL 5
 ITEM : RGB SYNC LEVEL
 Spec. : A = 40 ± 2 IRE (NTSC)
 A = 300 ± 14 mV (PAL)
2. On the setting menu, adjust as follows.
 PAGE : LEVEL 5
 ITEM : RGB SETUP LEVEL
 Spec. : B = 7.5 ± 0.5 IRE (NTSC)
 B = 0 ± 3 mV (PAL)
3. On the setting menu, adjust as follows.
 PAGE : LEVEL 5
 ITEM : RGB Y LEVEL
 Spec. : C = 100 ± 2 IRE (NTSC)
 C = 700 ± 14 mV (PAL)

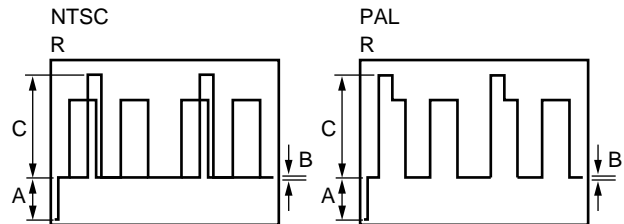

Setting after adjustment

- On the setting menu, set as follows.
 PAGE : LEVEL 7
 ITEM : TEST OUT → ENC

5-4. VA Gain Adjustment

Note

- Use a reflective chart (Reflection rate : 89.9 %) in this adjustment as possible. Adjust the color temperature to 3200 K exactly. If a pattern box is used, check it's state before use. Set the luminous intensity of the chart to 2000 lx.

Preparation

- OUTPUT/DCC switch (inside panel) → CAM/ON
- Shoot a gray-scale chart in the full underscan's picture frame.
- WHITE BAL switch (inside panel) → PRST
- AUTO W/B BAL switch (front panel) → BLK
(Perform the automatic black balance adjustment.)

Adjustment procedure

- Equipment : Oscilloscope
Test point : TP1/VA-167
Setting point : ●Lens IRIS
Spec. : $A = 320 \pm 8$ mV

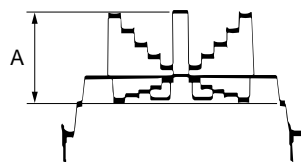

- On the setting menu, set as follows.
PAGE : FUNCTION 1/2
ITEM : TEST OUT → G
- Equipment : Waveform monitor
Test point : TEST OUT connector
(inside panel)
Adj. point : ●RV201/VA-167
Spec. : $B = 100 \pm 2$ IRE (NTSC)
 $B = 700 \pm 10$ mV (PAL)

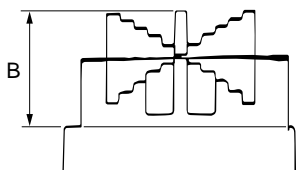

- On the setting menu, set as follows.
PAGE : FUNCTION 1/2
ITEM : TEST OUT → ENC
ITEM : GAMMA → OFF
- Select portion C by using the waveform monitor.

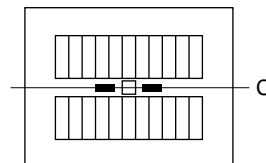

- Set the waveform monitor to the CHROMA mode.
- Equipment : Waveform monitor
Test point : TEST OUT connector
(inside panel)
Adj. point : ●RV101/VA-167
●RV301/VA-167
Spec. : Minimize carrier leak D by using the variable resistors alternately.



Setting after adjustment

- On the setting menu, set as follows.
PAGE : FUNCTION 1/2
ITEM : GAMMA → ON

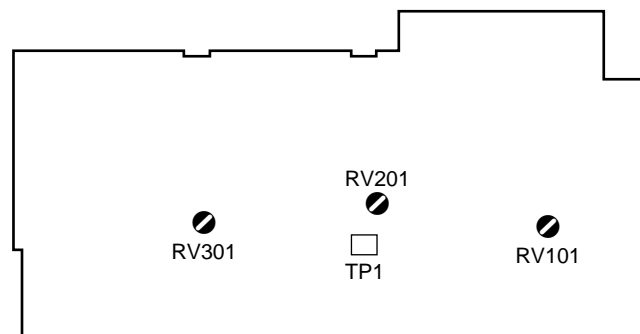

VA-167 Board (A side)

5-5. White Shading Adjustment

Preparation

- Lens IRIS → AUTO
- Shoot a fully occupied white area of pattern box in the underscan's picture frame.
- Waveform monitor setting
LUM mode
VOLT FULL SCALE range → 0.5

Adjustment procedure

Test point : TEST OUT connector

1. On the setting menu, set as follows.
PAGE : W-SHAD_G
ITEM : TEST OUT → G
2. Make the waveform to flat by UP and/or DOWN button on the inside panel according to the table below.
3. Adjust the shading for R and B channels in the same way.

TEST OUT	H SAW	V SAW	H PARA	V PARA
G W-SHAD_G	W-SHAD_G	W-SHAD_G	W-SHAD_G	W-SHAD_G
TEST OUT→G	H SAW	V SAW	H PARA	V PARA
R W-SHAD_R	W-SHAD_R	W-SHAD_R	W-SHAD_R	W-SHAD_R
TEST OUT→R	H SAW	V SAW	H PARA	V PARA
B W-SHAD_B	W-SHAD_B	W-SHAD_B	W-SHAD_B	W-SHAD_B
TEST OUT→B	H SAW	V SAW	H PARA	V PARA

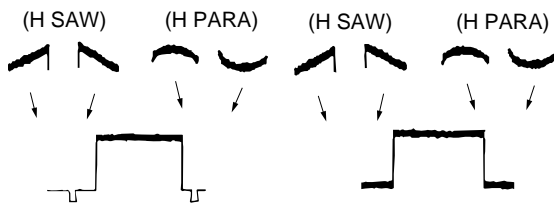

4. Set the lens to EXTENDER and adjust in the same way.

TEST OUT	H SAW	V SAW	H PARA	V PARA
G W-SHAD_G	W-SHAD_G	W-SHAD_G	W-SHAD_G	W-SHAD_G
TEST OUT→G	H SAW (EXT)	V SAW (EXT)	H PARA (EXT)	V PARA (EXT)
R W-SHAD_R	W-SHAD_R	W-SHAD_R	W-SHAD_R	W-SHAD_R
TEST OUT→R	H SAW (EXT)	V SAW (EXT)	H PARA (EXT)	V PARA (EXT)
B W-SHAD_B	W-SHAD_B	W-SHAD_B	W-SHAD_B	W-SHAD_B
TEST OUT→B	H SAW (EXT)	V SAW (EXT)	H PARA (EXT)	V PARA (EXT)

Setting after adjustment

- On the setting menu, set as follows.
PAGE : W-SHAD_B
ITEM : TEST OUT → ENC

5-6. Gamma Correction Adjustment

Preparation

- OUTPUT/DCC switch (inside panel) → CAM/ON
- Shoot a gray-scale chart in the full underscan's picture frame.
Setting point : ● Lens IRIS
Spec. : A (white level) = 100 ± 2 IRE

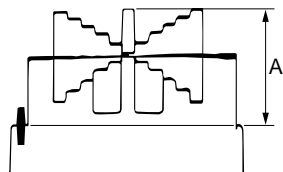

- On the setting menu, set as follows.
PAGE : LEVEL 6
ITEM : TEST OUT → G

Adjustment procedure

1. On the setting menu, adjust as follows.
PAGE : LEVEL 3
ITEM : MASTER GAMMA
Spec. : B = 63 ± 2 IRE (NTSC)
B = 420 ± 14 mV (PAL)

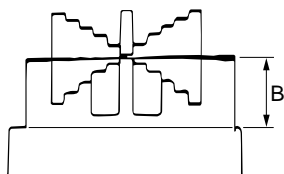

2. On the setting menu, set as follows.
PAGE : FUNCTION 1/2
ITEM : TEST OUT → ENC
ITEM : TEST SAW → ON
3. On the setting menu, adjust as follows.
PAGE : LEVEL 6
ITEM : R GAMMA
Spec. : Adjust the illuminated spot at the center of the vectorscope.

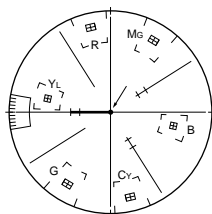

4. On the setting menu, adjust as follows.
PAGE : LEVEL 6
ITEM : B GAMMA
Spec. : Adjust the illuminated spot at the center of the vectorscope.
5. Repeat steps 3 and 4 several times, adjust the illuminated spot at the center of the vectorscope.
6. Make sure that the carrier leak at the portion B is not observed.

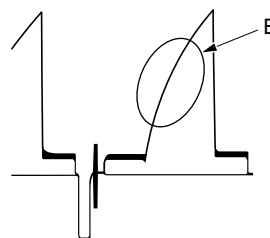

Setting after adjustment

- On the setting menu, set as follows.
PAGE : FUNCTION 1/2
ITEM : TEST SAW → OFF

5-7. Black Set Adjustment

Preparation

- Lens IRIS → CLOSE
- On the setting menu, set as follows.
PAGE : LEVEL 6
ITEM : TEST OUT → G

Adjustment procedure

Test point : TEST OUT connector

1. On the setting menu, adjust as follows.
PAGE : LEVEL 3
ITEM : MASTER BLACK
Spec. : A = 10 ± 1 IRE (NTSC)
A = 20 ± 7 mV (PAL)

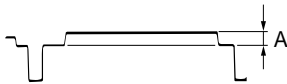

Setting after adjustment

- On the setting menu, set as follows.
PAGE : LEVEL 6
ITEM : TEST OUT → ENC
- MENU switch (inside panel) → OFF
- AUTO W/B BAL switch (front panel) → BLK
(Perform the automatic black balance adjustment.)

5-8. Flare Adjustment

Preparation

- OUTPUT/DCC switch (inside panel) → CAM/ON
- Shoot a gray-scale chart in the full underscan's picture frame.
Test point : TEST OUT connector (inside panel)
Setting point : ● Lens IRIS
Spec. : Open the lens iris by one step from the reference setting (NTSC : 100 ± 2 IRE, PAL : A = 700 ± 14 mV).

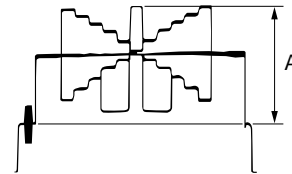

Adjustment procedure

Test point : TEST OUT connector

1. On the setting menu, set as follows.
PAGE : LEVEL 7
ITEM : G FLARE → 0
2. Select portion C by using the waveform monitor.

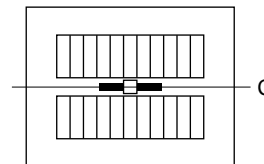

3. On the setting menu, adjust as follows.
PAGE : LEVEL 7
ITEM : R FLARE
Spec. : Minimize the carrier leak at portion B

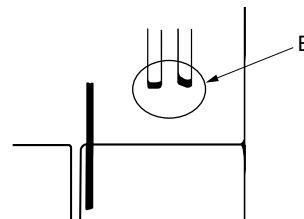

4. On the setting menu, adjust as follows.
PAGE : LEVEL 7
ITEM : B FLARE
Spec. : Minimize the carrier leak at portion B.
5. Repeat steps 3 and 4 several times.

5-9. Manual Knee and White Clip Adjustments

Preparation

- OUTPUT/DCC switch (inside panel) → CAM/OFF
- WHITE BAL switch (inside panel) → PRST
- GAIN switch (inside panel) → M (9 dB)
- On the setting menu, set as follows.
 - PAGE : FUNCTION 1/2
 - ITEM : TEST SAW → ON
 - PAGE : LEVEL 3
 - ITEM : WHITE CLIP → OFF

Adjustment procedure

Test point : TEST OUT connector

1. On the setting menu, set as follows.
 - PAGE : LEVEL 3
 - ITEM : KNEE SLOPE 1 → MIN
2. On the setting menu, adjust as follows.
 - PAGE : LEVEL 3
 - ITEM : KNEE POINT 1
 - Spec. : A = 85 ± 2 IRE (NTSC)
A = 595 ± 14 mV (PAL)
3. GAIN switch (inside panel) → H (18 dB)
4. On the setting menu, set as follows.
 - PAGE : LEVEL 3
 - ITEM : WHITE CLIP → ON
 - ITEM : KNEE SLOPE 1 → MAX
5. On the setting menu, adjust as follows.
 - PAGE : LEVEL 3
 - ITEM : WHT CLIP LEVEL
 - Spec. : B = 107 ± 2 IRE (NTSC)
B = 735 ± 10 mV (PAL)
6. GAIN switch (inside panel) → M (9 dB)
7. On the setting menu, set as follows.
 - PAGE : LEVEL 3
 - ITEM : WHITE CLIP → OFF
8. On the setting menu, adjust as follows.
 - PAGE : LEVEL 3
 - ITEM : KNEE SLOPE
 - Spec. : C = 109 ± 2 IRE (NTSC)
C = 763 ± 14 mV (PAL)

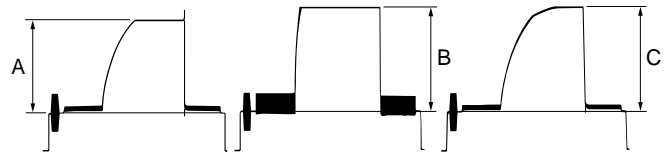

Setting after adjustment

- GAIN switch (inside panel) → L (0 dB)
- On the setting menu, set as follows.
 - PAGE : FUNCTION 1/2
 - ITEM : TEST SAW → OFF
 - PAGE : LEVEL 3
 - ITEM : WHITE CLIP → ON

Note

The values used in the above adjustment are for the conditions that the white clip level is set to 109 IRE (763 mV). When the white clip level is set to a value other than 109 IRE (763 mV), equate these values of knee slope adjustment and white clip adjustment.

5-10. Crispening Adjustment

Preparation

- On the setting menu, set as follows.
PAGE : FUNCTION 1/2
ITEM : DETAIL → ON
- OUTPUT/DCC switch (inside panel) → CAM/ON
- Shoot a gray-scale chart in the full underscan's picture frame.

Setting point : ● Lens IRIS
Spec. : A = 100 ± 2 IRE (NTSC)
A = 700 ± 14 mV (PAL)

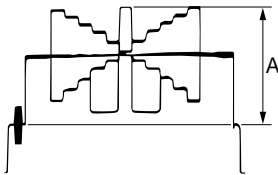

Adjustment procedure

Equipment : Black and white monitor
Test point : TEST OUT connector

1. On the setting menu, adjust as follows.
PAGE : LEVEL 1
ITEM : CRISPENING
Spec. : Reduce the noise on the screen to a permissible level.

5-11. Level Dependent Adjustment

Preparation

- On the setting menu, set as follows.
PAGE : FUNCTION 1/2
ITEM : DETAIL → ON
ITEM : TEST OUT → ENC
- OUTPUT/DCC switch (inside panel) → CAM/ON
- Shoot a gray-scale chart in the full underscan's picture frame.

Setting point : ● Lens IRIS
Spec. : A = 100 ± 2 IRE (NTSC)
A = 700 ± 14 mV (PAL)

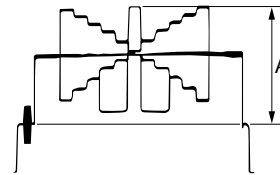

Adjustment procedure

Test point : TEST OUT connector

1. On the setting menu, adjust as follows.
PAGE : LEVEL 1
ITEM : LEVEL DEPEND
Spec. : Eliminate the detail signal from portion B.

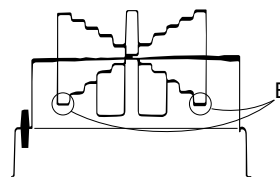

Note

- After this adjustment, be sure to perform 5-12. H/V Ratio Adjustment, and 5-13. Detail Level Adjustment, in that order.

5-12. H/V Ratio Adjustment

Preparation

- On the setting menu, set as follows.
PAGE : FUNCTION 1/2
ITEM : DETAIL → ON
ITEM : TEST OUT → ENC
- OUTPUT/DCC switch (inside panel) → CAM/ON
- Shoot a gray-scale chart in the full underscan's picture frame.
Setting point :  Lens IRIS
Spec. : A = 100 ±2 IRE (NTSC)
A = 700 ±14 mV (PAL)

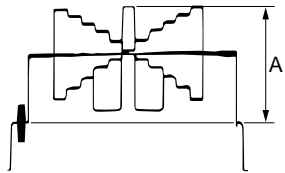

Adjustment procedure

Equipment : Black and white monitor
Test point : TEST OUT connector

- On the setting menu, adjust as follows.
PAGE : LEVEL 1
ITEM : V DTL LEVEL
Spec. : Adjust so that the H and V detail amounts which are added are equivalent.

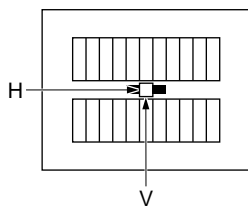

5-13. Detail Level Adjustment

Note

- Perform this adjustment, if necessary, to suit the customer's preferences.

Preparation

- On the setting menu, set as follows.
PAGE : FUNCTION 1/2
ITEM : DETAIL → ON
ITEM : TEST OUT → ENC
- Shoot a gray-scale chart in the full underscan's picture frame.
Setting point :  Lens IRIS
Spec. : A = 80 ±2 IRE (NTSC)
A = 560 ±14 mV (PAL)

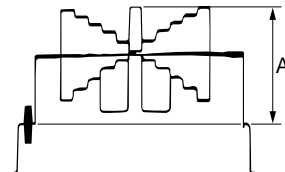

Adjustment procedure

Test point : TEST OUT connector

- On the setting menu, adjust as follows.
PAGE : LEVEL 1
ITEM : DETAIL LEVEL (Factory setting : 0)
Spec. : Set to the detail signal which is added to each step in the gray-scale chart.

5-14. Skin Tone Adjustment

Note

- Perform this adjustment, if necessary, to suit the customer's preferences.

Preparation

- On the setting menu, set as follows.

PAGE : LEVEL 2
 ITEM : SKIN TONE DTL → ON
 ITEM : SKIN TONE IND. → ON

- Shoot a person's face.

Adjustment procedure

Test point : TEST OUT, VIDEO OUT connector

1. On the setting menu, set as follows.

PAGE : LEVEL 2
 ITEM : SKIN TONE DET → ON

2. Shoot a person's face in the central of the viewfinder.

3. Push the rotary switch (front panel).
 (Display the detect area in zebra pattern.)

4. Perform the adjustment in this step, if necessary.

On the setting menu, adjust as follows.

PAGE : LEVEL 2
 ITEM : X : Component of red (center)
 Y : Component of blue (center)
 dX : Component of red (range)
 dY : Component of blue (range)

Display the skin detail detect area in zebra pattern.

Adjust zebra pattern displays only normal area.

5. On the setting menu, adjust as follows.

PAGE : LEVEL 2
 ITEM : SUPPRESS LEVEL (Factory setting : 0)
 Spec. : Set the level to the desired detail level.

Setting after adjustment

PAGE : LEVEL 2
 ITEM : SKIN TONE DTL → OFF
 ITEM : SKIN TONE IND. → OFF
 ITEM : SKIN TONE DET → OFF

5-15. Zebra Adjustment

Preparation

- ZEBRA switch (viewfinder) → ON
- On the setting menu, set as follows.
 - PAGE : FUNCTION 1/2
 - ITEM : TEST OUT → R, G or B
 - PAGE : VF SETTING
 - ITEM : ZEBRA SELECT → 1
 - ITEM : ZEBRA1 APT → MIN
- OUTPUT/DCC switch (inside panel) → CAM/ON
- Shoot a gray-scale chart in the full underscan's picture frame.
 - Setting point : ● Lens IRIS
 - Spec. : A = 100 ± 2 IRE (NTSC)
 - A = 700 ± 14 mV (PAL)

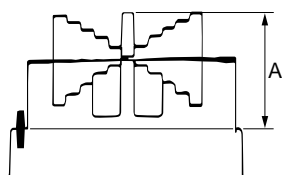

5. On the setting menu, set as follows.
 - PAGE : VF SETTING
 - ITEM : ZEBRA SELECT → 2
6. On the setting menu, adjust as follows.
 - PAGE : VF SETTING
 - ITEM : ZEBRA2 DETECT
 - Spec. : Set the condition that zebra pattern appear at the portion B.

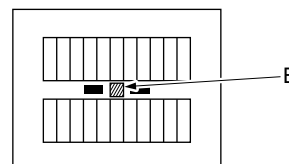

Setting after adjustment

- PAGE : VF SETTING
- ITEM : ZEBRA SELECT → 1

Adjustment procedure

Test point : TEST OUT connector

1. On the setting menu, adjust as follows.
 - PAGE : VF SETTING
 - ITEM : ZEBRA1 DETECT
 - Spec. : Set the condition that zebra pattern appear at the portions A.

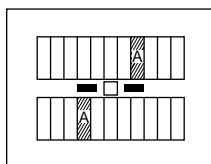

2. On the setting menu, set as follows.
 - PAGE : FUNCTION 1/2
 - ITEM : TEST SAW → ON
3. On the setting menu, adjust as follows.
 - PAGE : VF SETTING
 - ITEM : ZEBRA1 APT (Factory setting : 0)
 - Spec. : Set the desired width of detection.
4. On the setting menu, set as follows.
 - PAGE : FUNCTION 1/2
 - ITEM : TEST SAW → OFF

5-16. Automatic Iris Adjustment

Preparation

- On the setting menu, set as follows.
 PAGE : LEVEL 7
 ITEM : TEST OUT → ENC
- OUTPUT/DCC switch (inside panel) → CAM/ON
- Shoot a gray-scale chart in the full underscan's picture frame.
- Lens IRIS → AUTO

Adjustment procedure

Test point : TEST OUT connector

1. On the setting menu, adjust as follows.
 PAGE : LEVEL 9
 ITEM : IRIS MODE
 Spec. : Set the automatic iris operation mode depending on the application.
 Automatic iris operation mode setting can be done from the average level to peak-to-peak level of the video signal.
 IRIS MODE = MIN → peak-to-peak level
 IRIS MODE = MAX → average level
2. On the setting menu, adjust as follows.
 PAGE : LEVEL 9
 ITEM : IRIS SET
 Spec. : A = 100 ±2 IRE (NTSC)
 A = 700 ±14 mV (PAL)

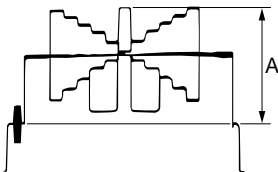

3. On the setting menu, set as follows.
 PAGE : LEVEL 9
 ITEM : IRIS WEIGHT → 0 (MIN)
4. Shoot a avoid working area of auto iris in the white window chart.

5. On the setting menu, adjust as follows.
 PAGE : LEVEL 9
 ITEM : IRIS WEIGHT
 Spec. : Increment the IRIS WEIGHT value until the lens iris is open.
6. On the setting menu, adjust as follows.
 PAGE : LEVEL 9
 ITEM : IRIS SPEED (Factory setting : 0)
 Spec. : Set to the desired operation speed of auto iris.
7. On the setting menu, set as follows.
 PAGE : LEVEL 9
 ITEM : CLIP HIGH LIGHT → ON or OFF
 Spec. : Set to the desired position.

Section 6

Electrical Alignment (Only for DNW-9WS/9WSP/90WS/90WSP)

6-1. General Information for Electrical Adjustment

6-1-1. Note for Adjustment

Before adjustment, set the main POWER switch to on and the VTR switch to SAVE, then warm up the camera for about 10 minutes.

Be sure to set the main POWER switch of the external DC power supply to off before extracting the plug-in board.

Indication at the top right on the viewfinder screen.

In adjustment on the setting menu, a bar sometimes appears at the top right on the viewfinder screen. The bar indicates the current setting state and adjustable range for the selected item.

Screen mode setting

Sets the screen mode as follows before performing the adjustment of the each page.

1. Setting menu
PAGE : WIDE SCREEN
ITEM : 16:9/4:3 MODE
2. Sets the screen mode as in the each page.
When the screen mode is not written, both "16:9" and "4:3" modes are acceptable for adjustment.

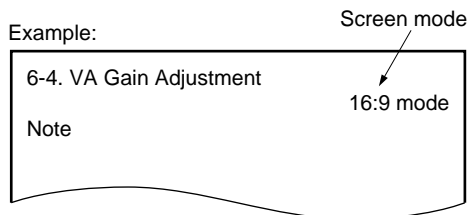

6-1-2. Equipment/Fixtures

- Oscilloscope
Tektronix 2465 or equivalent
- Waveform monitor/Vectorscope
Tektronix 1750/1751 or equivalent
- Monitor
Sony BVM-1410/1411P or equivalent
- Pattern box (PTB-500, 90 - 240 Vac)
J-6029-140-B
- Gray scale chart (4:3)
J-6026-130-A

6-1-3. Initial Setting for Switches

Execute the camera system alignment using the ENG mode in the SETUP menu. When the setting mode is changed ENG, set switches as follows.

1. Set the POWER switch to off.
2. S4-1 (DCP-1 board) → OFF
3. S1 (DCP-1 board) → OFF
4. While holding down the rotary encoder, turn the power ON

Note

When adjustment is performed in the ENG mode, the values of items adjusted in the USER mode become 0.

Initial Setting

Before performing adjustment, set switches as follows, If the setting of the GAIN switch is changed from the factory set value, reset it to its original value by referring to the operation manual.

Inside panel :

VTR SAVE/STBY switch	→ STBY
GAIN switch	→ L (0 dB)
OUTPUT/DCC switch	→ CAM/OFF
MENU switch	→ OFF
WHITE BAL switch	→ PRST

Front panel :

SHUTTER switch	→ OFF
Filter selector	→ 1

Lens :

LENS	→ MANU
IRIS	→ (CLOSE)

SETUP menu :

- MASTER GAIN
 - LOW → 0 dB
 - MID → 9 dB
 - HIGH → 18 dB
- FUNCTION 1/2
 - TEST OUT → ENC
 - DATAIL → ON
 - SKIN TONE DTL → OFF
 - MATRIX → OFF
 - GAMMA → ON
 - CHROMA → ON
 - TEST SAW → OFF

- FUNCTION 2/2
 - GENLOCK → ON
 - CAM RET → OFF
 - FILTER INH → ON
- LEVEL 3
 - KNEE SELECT → ON
 - WHITE CLIP → ON
- LEVEL 4
 - R-Y → ON
 - B-Y → ON

6-2. ENC Level Adjustment

16:9 and 4:3 modes

Preparation

- OUTPUT/DCC switch (inside panel) → BARS

Adjustment procedure

Equipment: Waveform monitor

Test point: VIDEO OUT connector

1. Put the unit into the 16:9 mode.
2. On the setting menu, adjust as follows.

PAGE : LEVEL 5
ITEM : ENC SYNC LEVEL
Spec. : A = 40 ± 1 IRE (NTSC)
A = 300 ± 7 mV (PAL)

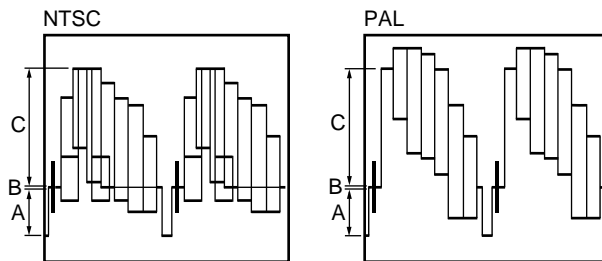

3. On the setting menu, adjust as follows.

PAGE : LEVEL 5
ITEM : ENC SETUP LEV.
Spec. : B = 7.5 ± 0.5 IRE (NTSC)
B = 0 ± 3 mV (PAL)

4. On the setting menu, adjust as follows.

PAGE : LEVEL 5
ITEM : ENC Y LEV. (WS)
Spec. : C = 100 ± 2 IRE (NTSC)
C = 700 ± 14 mV (PAL)

5. Put the unit into the 4:3 mode.

6. On the setting menu, adjust as follows.

PAGE : LEVEL 5
ITEM : ENC Y LEV.
Spec. : C = 100 ± 2 IRE (NTSC)
C = 700 ± 14 mV (PAL)

6-3. TEST OUT Level Adjustment

16:9 and 4:3 mode

Preparation

- OUTPUT/DCC switch (inside panel) → BARS
- On the setting menu, set as follows.

PAGE : LEVEL 7
ITEM : TEST OUT → R, G or B

Adjustment procedure

Test point: TEST OUT connector

1. Put the unit into the 16:9 mode.
2. On the setting menu, adjust as follows.

PAGE : LEVEL 5
ITEM : RGB SYNC LEV.
Spec. : A = 40 ± 2 IRE (NTSC)
A = 300 ± 14 mV (PAL)

3. On the setting menu, adjust as follows.

PAGE : LEVEL 5
ITEM : RGB SETUP LEV.
Spec. : B = 7.5 ± 0.5 IRE (NTSC)
B = 0 ± 3 mV (PAL)

4. On the setting menu, adjust as follows.

PAGE : LEVEL 5
ITEM : RGB LEVEL (WS)
Spec. : C = 100 ± 2 IRE (NTSC)
C = 700 ± 14 mV (PAL)

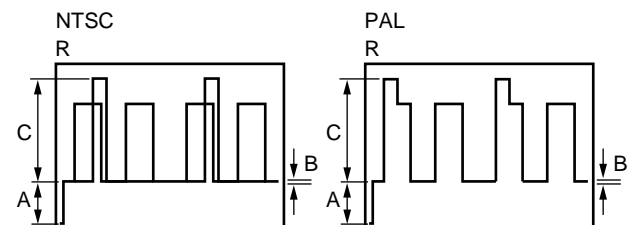

5. Put the unit into the 4:3 mode.

6. On the setting menu, adjust as follows.

PAGE : LEVEL 5
ITEM : RGB LEVEL
Spec. : C = 100 ± 2 IRE (NTSC)
C = 700 ± 14 mV (PAL)

Setting after adjustment

- On the setting menu, set as follows.

PAGE : LEVEL 7
ITEM : TEST OUT → ENC

6-4. VA Gain Adjustment

16:9 mode

Note

- Use a reflective chart (Reflection rate: 89.9 %) in this adjustment as possible. Adjust the color temperature to 3200 K exactly. If a pattern box is used, check it's state before use. Set the luminous intensity of the chart to 2000 lx.
- If the "16:9" chart is not keep on hand, it is acceptable to perform the adjustment of "4:3" mode using a "4:3" chart.

Preparation

- OUTPUT/DCC switch (inside panel) → CAM/ON
- Shoot a gray-scale chart (16:9) in the full underscan's picture frame.
- WHITE BAL switch (inside panel) → PRST
- AUTO W/B BAL switch (front panel) → BLK
(Perform the automatic black balance adjustment.)

Adjustment procedure

1. Equipment : Oscilloscope
 Test point : TP1/VA-167
 Setting point : ● Lens IRIS
 Spec. : $A = 320 \pm 8 \text{ mV}$

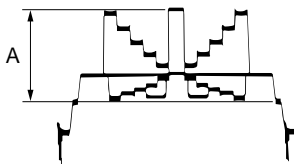

2. On the setting menu, set as follows.
 PAGE : FUNCTION 1/2
 ITEM : TEST OUT → G
3. Equipment : Waveform monitor
 Test point : TEST OUT connector (inside panel)
 Adj. point : ●RV201/VA-167
 Spec. : $B = 100 \pm 2 \text{ IRE (NTSC)}$
 $B = 700 \pm 10 \text{ mV (PAL)}$

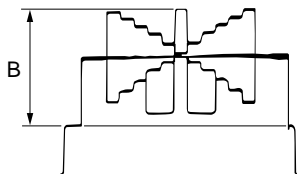

4. On the setting menu, set as follows.
 PAGE : FUNCTION 1/2
 ITEM : TEST OUT → ENC
 ITEM : GAMMA → OFF
5. Select portion C by using the waveform monitor.

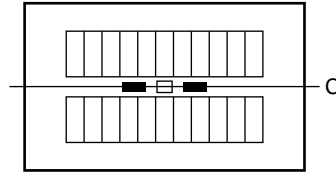

6. Set the waveform monitor to the CHROMA mode.
7. Equipment : Waveform monitor
 Test point : TEST OUT connector (inside panel)
 Adj. point : ●RV101/VA-167
 ●RV301/VA-167
 Spec. : Minimize carrier leak D by using the variable resistors alternately.



Setting after adjustment

- On the setting menu, set as follows.
 PAGE : FUNCTION 1/2
 ITEM : GAMMA → ON

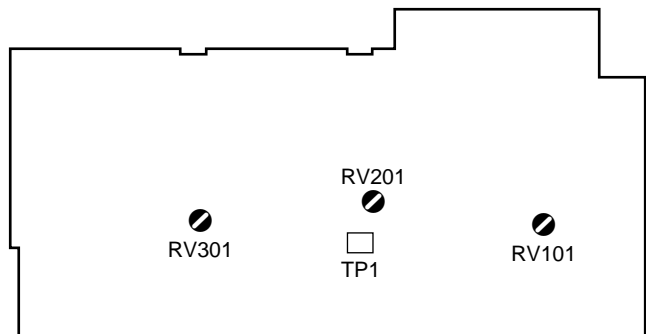

VA-167 Board (A side)

6-5. White Shading Adjustment

16:9 mode

Preparation

- Lens IRIS → AUTO
- Shoot a fully occupied white area of pattern box in the underscan's picture frame.
- Waveform monitor setting
LUM mode
VOLT FULL SCALE range → 0.5

Adjustment procedure

Test point: TEST OUT connector

1. On the setting menu, set as follows.
PAGE : W-SHAD_G
ITEM : TEST OUT → G
2. Make the waveform to flat by UP and/or DOWN button on the inside panel according to the table below.
3. Adjust the shading for R and B channels in the same way.

	TEST OUT	H SAW	V SAW	H PARA	V PARA
G	W-SHAD_G TEST OUT → G	W-SHAD_G H SAW	W-SHAD_G V SAW	W-SHAD_G H PARA	W-SHAD_G V PARA
R	W-SHAD_R TEST OUT → R	W-SHAD_R H SAW	W-SHAD_R V SAW	W-SHAD_R H PARA	W-SHAD_R V PARA
B	W-SHAD_B TEST OUT → B	W-SHAD_B H SAW	W-SHAD_B V SAW	W-SHAD_B H PARA	W-SHAD_B V PARA

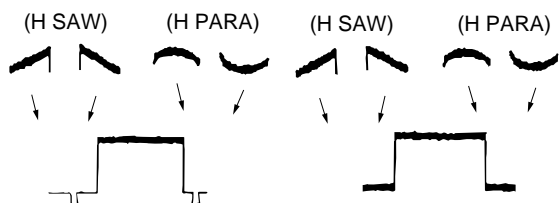

4. Set the lens to EXTENDER and adjust in the same way.

	TEST OUT	H SAW	V SAW	H PARA	V PARA
G	W-SHAD_G TEST OUT → G (EXT)	W-SHAD_G H SAW (EXT)	W-SHAD_G V SAW (EXT)	W-SHAD_G H PARA (EXT)	W-SHAD_G V PARA
R	W-SHAD_R TEST OUT → R (EXT)	W-SHAD_R H SAW (EXT)	W-SHAD_R V SAW (EXT)	W-SHAD_R H PARA (EXT)	W-SHAD_R V PARA
B	W-SHAD_B TEST OUT → B (EXT)	W-SHAD_B H SAW (EXT)	W-SHAD_B V SAW (EXT)	W-SHAD_B H PARA (EXT)	W-SHAD_B V PARA

Setting after adjustment

- On the setting menu, set as follows.
PAGE : W-SHAD_B
ITEM : TEST OUT → ENC

6-6. Gamma Correction Adjustment

16:9 mode

Preparation

- OUTPUT/DCC switch (inside panel) → CAM/ON
- Shoot a gray-scale chart (16:9) in the full underscan's picture frame.

Setting point : ● Lens IRIS

Spec. : A (white level) = 100 ± 2 IRE

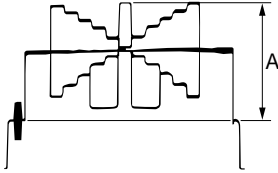

- On the setting menu, set as follows.

PAGE : LEVEL 6

ITEM : TEST OUT → G

Adjustment procedure

1. On the setting menu, adjust as follows.

PAGE : LEVEL 3

ITEM : MASTER GAMMA

Spec. : B = 63 ± 2 IRE (NTSC)
B = 420 ± 14 mV (PAL)

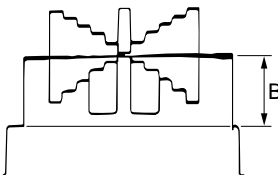

2. On the setting menu, set as follows.

PAGE : FUNCTON 1/2

ITEM : TEST OUT → ENC

ITEM : TEST SAW → ON

3. On the setting menu, adjust as follows.

PAGE : LEVEL 6

ITEM : R GAMMA

Spec. : Adjust the illuminated spot at the center of the vectorscope.

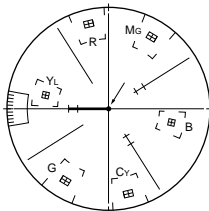

4. On the setting menu, adjust as follows.

PAGE : LEVEL 6

ITEM : B GAMMA

Spec. : Adjust the illuminated spot at the center of the vectorscope.

5. Repeat steps 3 and 4 several times, adjust the illuminated spot at the center of the vectorscope.

6. Make sure that the carrier leak at the portion B is not observed.

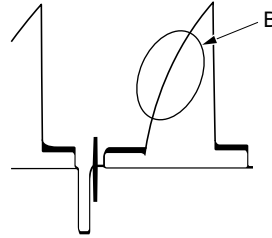

Setting after adjustment

- On the setting menu, set as follows.

PAGE : FUNCTION 1/2

ITEM : TEST SAW → OFF

6-7. Black Set Adjustment

Preparation

- Lens IRIS → CLOSE
- On the setting menu, set as follows.
 - PAGE : LEVEL 6
 - ITEM : TEST OUT → G

Adjustment procedure

Test point: TEST OUT connector

1. On the setting menu, adjust as follows.
 - PAGE : LEVEL 3
 - ITEM : MASTER BLACK
 - Spec. : A = 10 ± 1 IRE (NTSC)
A = 20 ± 7 mV (PAL)

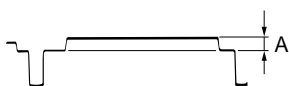

Setting after adjustment

- On the setting menu, set as follows.
 - PAGE : LEVEL 6
 - ITEM : TEST OUT → ENC
- MENU switch (inside panel) → OFF
- AUTO W/B BAL switch (front panel) → BLK
(Perform the automatic black balance adjustment.)

6-8. Flare Adjustment

Preparation

- On the setting menu, set as follows.
 - PAGE : LEVEL 6
 - ITEM : TEST OUT → ENC
- OUTPUT/DCC switch (inside panel) → CAM/ON
- Shoot a gray-scale chart (16:9) in the full underscan's picture frame.
 - Test point : TEST OUT connector (inside panel)
 - Setting point : ● Lens IRIS
 - Spec. : Open the lens iris by one step from the reference setting (NTSC: 100 ± 2 IRE, PAL: A = 700 ± 14 mV).

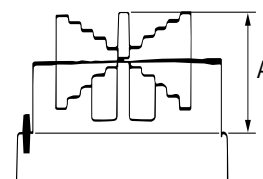

Adjustment procedure

Test point: TEST OUT connector

1. On the setting menu, set as follows.
 - PAGE : LEVEL 7
 - ITEM : G FLARE → 0
2. Select portion C by using the waveform monitor.

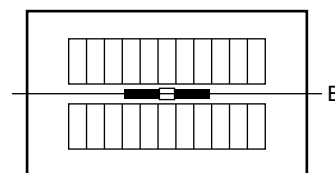

3. On the setting menu, adjust as follows.
 - PAGE : LEVEL 7
 - ITEM : R FLARE
 - Spec. : Minimize the carrier leak at portion B

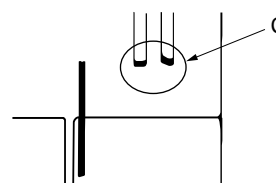

4. On the setting menu, adjust as follows.
 - PAGE : LEVEL 7
 - ITEM : B FLARE
 - Spec. : Minimize the carrier leak at portion B.
5. Repeat steps 3 and 4 several times.

6-9. Manual Knee and White Clip Adjustments

Preparation

- OUTPUT/DCC switch (inside panel) → CAM/OFF
- WHITE BAL switch (inside panel) → PRST
- GAIN switch (inside panel) → M (9 dB)
- On the setting menu, set as follows.

PAGE	: FUNCTION 1/2
ITEM	: TEST SAW → ON
PAGE	: LEVEL 3
ITEM	: WHITE CLIP → OFF

Adjustment procedure

Test point: TEST OUT connector

1. On the setting menu, set as follows.

PAGE	: LEVEL 3
ITEM	: KNEE SLOPE 1 → MIN
2. On the setting menu, adjust as follows.

PAGE	: LEVEL 3
ITEM	: KNEE POINT 1
Spec.	: A = 85 ± 2 IRE (NTSC)
	: A = 595 ± 14 mV (PAL)
3. GAIN switch (inside panel) → H (18 dB)
4. On the setting menu, set as follows.

PAGE	: LEVEL 3
ITEM	: WHITE CLIP → ON
ITEM	: KNEE SLOPE 1 → MAX
5. On the setting menu, adjust as follows.

PAGE	: LEVEL 3
ITEM	: WHT CLIP LEVEL
Spec.	: B = 107 ± 2 IRE (NTSC)
	: B = 735 ± 10 mV (PAL)
6. GAIN switch (inside panel) → M (9 dB)
7. On the setting menu, set as follows.

PAGE	: LEVEL 3
ITEM	: WHITE CLIP → OFF
8. On the setting menu, adjust as follows.

PAGE	: LEVEL 3
ITEM	: KNEE SLOPE
Spec.	: C = 109 ± 2 IRE (NTSC)
	: C = 763 ± 14 mV (PAL)

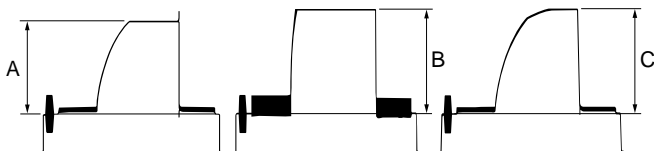

Setting after adjustment

- GAIN switch (inside panel) → L (0 dB)
- On the setting menu, set as follows.

PAGE	: FUNCTION 1/2
ITEM	: TEST SAW → OFF
PAGE	: LEVEL 3
ITEM	: WHITE CLIP → ON

Note

The values used in the above adjustment are for the conditions that the white clip level is set to 109 IRE (763 mV). When the white clip level is set to a value other than 109 IRE (763 mV), equate these values of knee slope adjustment and white clip adjustment.

6-10. Crispening Adjustment (16:9)

16:9 mode

Preparation

- On the setting menu, set as follows.
 PAGE : FUNCTION 1/2
 ITEM : DETAIL → ON
- OUTPUT/DCC switch (inside panel) → CAM/ON
- Shoot a gray-scale chart (16:9) in the full underscan's picture frame.
 Setting point : ● Lens IRIS
 Spec. : A = 100 ± 2 IRE (NTSC)
 A = 700 ± 14 mV (PAL)

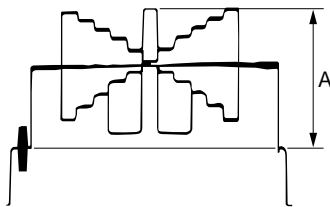

Adjustment procedure

Equipment : Black and white monitor
 Test point : TEST OUT connector

1. On the setting menu, adjust as follows.
 PAGE : LEVEL 1
 ITEM : CRISPENING
 Spec. : Reduce the noise on the screen to a permissible level.

6-11. Level Dependant Adjustment (16:9)

16:9 mode

Preparation

- On the setting menu, set as follows.
 PAGE : FUNCTION 1/2
 ITEM : DETAIL → ON
 ITEM : TEST OUT → ENC
- OUTPUT/DCC switch (inside panel) → CAM/ON
- Shoot a gray-scale chart (16:9) in the full underscan's picture frame.
 Setting point : ● Lens IRIS
 Spec. : A = 100 ± 2 IRE (NTSC)
 A = 700 ± 14 mV (PAL)

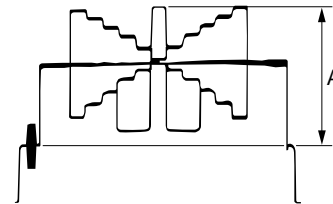

Adjustment procedure

Test point: TEST OUT connector

1. On the setting menu, adjust as follows.
 PAGE : LEVEL 1
 ITEM : LEVEL DEPEND
 Spec. : Eliminate the detail signal from portion B.

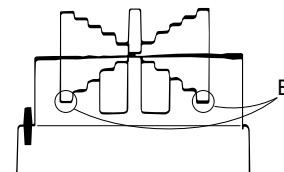

Note

- After this adjustment, be sure to perform 6-12. H/V Ratio Adjustment, and 6-13. Detail Level Adjustment, in that order.

6-12. H/V Ratio Adjustment (16:9)

16:9 mode

Preparation

- On the setting menu, set as follows.
 PAGE : FUNCTION 1/2
 ITEM : DETAIL → ON
 ITEM : TEST OUT → ENC
- OUTPUT/DCC switch (inside panel) → CAM/ON
- Shoot a gray-scale chart (16:9) in the full underscan's picture frame.
 Setting point : ● Lens IRIS
 Spec. : A = 100 ± 2 IRE (NTSC)
 A = 700 ± 14 mV (PAL)

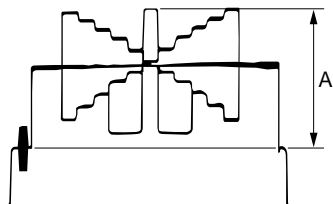

Adjustment procedure

Equipment: Black and white monitor
 Test point: TEST OUT connector

1. On the setting menu, adjust as follows.
 PAGE : LEVEL 1
 ITEM : V DTL LEVEL
 Spec. : Adjust so that the H and V detail amounts which are added are equivalent.

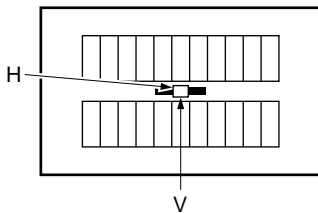

6-13. Detail Level Adjustment (16:9)

16:9 mode

Note

- Perform this adjustment, if necessary, to suit the customer's preferences.

Preparation

- On the setting menu, set as follows.
 PAGE : FUNCTION 1/2
 ITEM : DETAIL → ON
 ITEM : TEST OUT → ENC
- Shoot a gray-scale chart (16:9) in the full underscan's picture frame.
 Setting point : ● Lens IRIS
 Spec. : A = 80 ± 2 IRE (NTSC)
 A = 560 ± 14 mV (PAL)

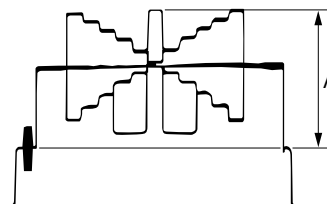

Adjustment procedure

Test point: TEST OUT connector

1. On the setting menu, adjust as follows.
 PAGE : LEVEL 1
 ITEM : DETAIL LEVEL (Factory setting: 0)
 Spec. : Set to the detail signal which is added to each step in the gray-scale chart.

6-14. Crispening Adjustment (4:3)

4:3 mode

Preparation

- On the setting menu, set as follows.
PAGE : FUNCTION 1/2
ITEM : DETAIL → ON
- OUTPUT/DCC switch (inside panel) → CAM/ON
- Shoot a gray-scale chart (4:3) in the full underscan's picture frame.
Setting point : ● Lens IRIS
Spec. : A = 100 ± 2 IRE (NTSC)
A = 700 ± 14 mV (PAL)

Adjustment procedure

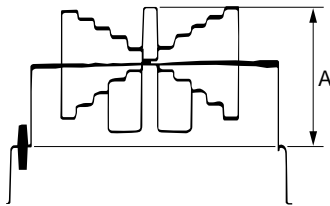

Equipment : Black and white monitor
Test point : TEST OUT connector

1. On the setting menu, adjust as follows.
PAGE : LEVEL 1
ITEM : CRISPENING
Spec. : Reduce the noise on the screen to a permissible level.

6-15. Level Dependent Adjustment (4:3)

4:3 mode

Preparation

- On the setting menu, set as follows.
PAGE : FUNCTION 1/2
ITEM : DETAIL → ON
ITEM : TEST OUT → ENC
- OUTPUT/DCC switch (inside panel) → CAM/ON
- Shoot a gray-scale chart (4:3) in the full underscan's picture frame.
Setting point : ● Lens IRIS
Spec. : A = 100 ± 2 IRE (NTSC)
A = 700 ± 14 mV (PAL)

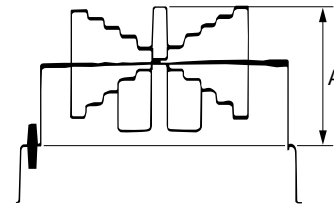

Adjustment procedure

Test point: TEST OUT connector

1. On the setting menu, adjust as follows.
PAGE : LEVEL 1
ITEM : LEVEL DEPEND
Spec. : Eliminate the detail signal from portion B.

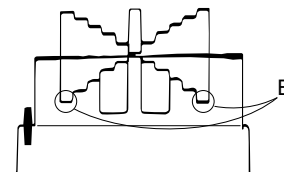

Note

- After this adjustment, be sure to perform 6-16. H/V Ratio Adjustment, and 6-17. Detail Level Adjustment, in that order.

6-16. H/V Ratio Adjustment (4:3)

4:3 mode

Preparation

- On the setting menu, set as follows.
 PAGE : FUNCTION 1/2
 ITEM : DETAIL → ON
 ITEM : TEST OUT → ENC
- OUTPUT/DCC switch (inside panel) → CAM/ON
- Shoot a gray-scale chart (4:3) in the full underscan's picture frame.
 Setting point : ● Lens IRIS
 Spec. : A = 100 ± 2 IRE (NTSC)
 A = 700 ± 14 mV (PAL)

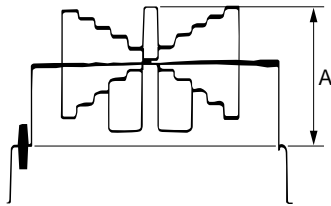

Adjustment procedure

Equipment: Black and white monitor
 Test point: TEST OUT connector

1. On the setting menu, adjust as follows.
 PAGE : LEVEL 1
 ITEM : V DTL LEVEL
 Spec. : Adjust so that the H and V detail amounts which are added are equivalent.

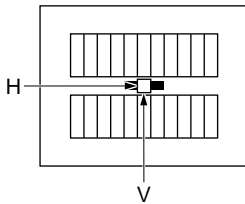

6-17. Detail Level Adjustment (4:3)

4:3 mode

Note

- Perform this adjustment, if necessary, to suit the customer's preferences.

Preparation

- On the setting menu, set as follows.
 PAGE : FUNCTION 1/2
 ITEM : DETAIL → ON
 ITEM : TEST OUT → ENC
- Shoot a gray-scale chart (4:3) in the full underscan's picture frame.
 Setting point : ● Lens IRIS
 Spec. : A = 80 ± 2 IRE (NTSC)
 A = 560 ± 14 mV (PAL)

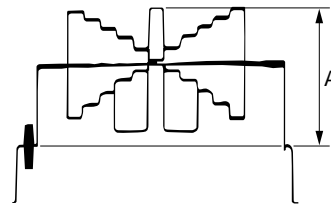

Adjustment procedure

Test point: TEST OUT connector

1. On the setting menu, adjust as follows.
 PAGE : LEVEL 1
 ITEM : DETAIL LEVEL (Factory setting: 0)
 Spec. : Set to the detail signal which is added to each step in the gray-scale chart.

6-18. Skin Tone Adjustment

Note

- Perform this adjustment, if necessary, to suit the customer's preferences.

Preparation

- On the setting menu, set as follows.
 - PAGE : LEVEL 2
 - ITEM : SKIN TONE DTL → ON
 - ITEM : SKIN TONE IND. → ON
- Shoot a person's face.

Adjustment procedure

Test point: TEST OUT, VIDEO OUT connector

1. On the setting menu, set as follows.
 - PAGE : LEVEL 2
 - ITEM : SKIN TONE DET → ON
2. Shoot a person's face in the central of the viewfinder.
3. Push the rotary switch (front panel).
(Display the detect area in zebra pattern.)
4. Perform the adjustment in this step, if necessary.
On the setting menu, adjust as follows.
 - PAGE : LEVEL 2
 - ITEM : X : Component of red (center)
 - Y : Component of blue (center)
 - dX : Component of red (range)
 - dY : Component of blue (range)

Display the skin detail detect area in zebra pattern.
Adjust zebra pattern displays only normal area.
5. On the setting menu, adjust as follows.
 - PAGE : LEVEL 2
 - ITEM : SUPPRESS LEVEL (Factory setting: 0)
 - Spec. : Set the level to the desired detail level.

Setting after adjustment

- PAGE : LEVEL 2
- ITEM : SKIN TONE DTL → OFF
- ITEM : SKIN TONE IND. → OFF
- ITEM : SKIN TONE DET → OFF

6-19. Zebra Adjustment

Preparation

- ZEBRA switch (viewfinder) → ON
- On the setting menu, set as follows.
 - PAGE : FUNCTION 1/2
 - ITEM : TEST OUT → R, G or B
 - PAGE : VF SETTING
 - ITEM : ZEBRA SELECT → 1
 - ITEM : ZEBRA1 APT → MIN
- OUTPUT/DCC switch (inside panel) → CAM/ON
- Shoot a gray-scale chart in the full underscan's picture frame.

Setting point : ● Lens IRIS
 Spec. : A = 100 ± 2 IRE (NTSC)
 A = 700 ± 14 mV (PAL)

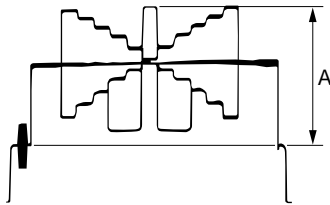

Adjustment procedure

Test point: TEST OUT connector

1. On the setting menu, adjust as follows.
 - PAGE : VF SETTING
 - ITEM : ZEBRA1 DETECT
 - Spec. : Set the condition that zebra pattern appear at the portions A.

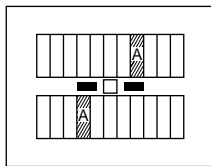

2. On the setting menu, set as follows.
 - PAGE : FUNCTION 1/2
 - ITEM : TEST SAW → ON
3. On the setting menu, adjust as follows.
 - PAGE : VF SETTING
 - ITEM : ZEBRA1 APT (Factory setting: 0)
 - Spec. : Set the desired width of detection.
4. On the setting menu, set as follows.
 - PAGE : FUNCTION 1/2
 - ITEM : TEST SAW → OFF

5. On the setting menu, set as follows.
 - PAGE : VF SETTING
 - ITEM : ZEBRA SELECT → 2
6. On the setting menu, adjust as follows.
 - PAGE : VF SETTING
 - ITEM : ZEBRA2 DETECT
 - Spec. : Set the condition that zebra pattern appear at the portion B.

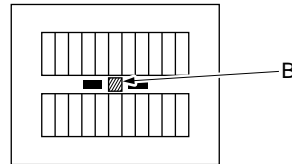

Setting after adjustment

PAGE : VF SETTING
 ITEM : ZEBRA SELECT → 1

6-20. Automatic Iris Adjustment

16:9 mode

Preparation

- On the setting menu, set as follows.
PAGE : LEVEL 7
ITEM : TEST OUT → ENC
- OUTPUT/DCC switch (inside panel) → CAM/ON
- Shoot a gray-scale chart (16:9) in the full underscan's picture frame.
- Lens IRIS → AUTO

Adjustment procedure

Test point: TEST OUT connector

1. On the setting menu, adjust as follows.
PAGE : LEVEL 9
ITEM : IRIS MODE
Spec. : Set the automatic iris operation mode depending on the application.

Automatic iris operation mode setting can be done from the average level to peak-to-peak level of the video signal.

IRIS MODE = MIN → peak-to-peak level

IRIS MODE = MAX → average level

2. On the setting menu, adjust as follows.
PAGE : LEVEL 9
ITEM : IRIS SET
Spec. : $A = 100 \pm 2$ IRE (NTSC)
 $A = 700 \pm 14$ mV (PAL)

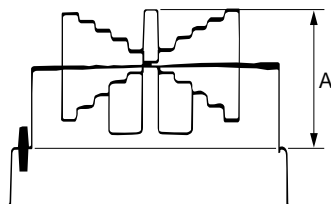

3. On the setting menu, set as follows.
PAGE : LEVEL 9
ITEM : IRIS WEIGHT → 0 (MIN)
4. Shoot a avoid working area of auto iris in the white window chart?
5. On the setting menu, adjust as follows.
PAGE : LEVEL 9
ITEM : IRIS WEIGHT
Spec. : Increment the IRIS WEIGHT value until the lens iris is open.

6. On the setting menu, adjust as follows.
PAGE : LEVEL 9
ITEM : IRIS SPEED (Factory setting: 0)
Spec. : Set to the desired operation speed of auto iris.

Section 7

Periodic Maintenance and Inspection

7-1. Cleaning

To make the most of the functions, deliver the full performances of this unit and to lengthen the life of the unit and tape, clean the parts often.

7-1-1. General Information for Cleaning

1. Index

This section explains the cleaning of parts as shown in the figure below.

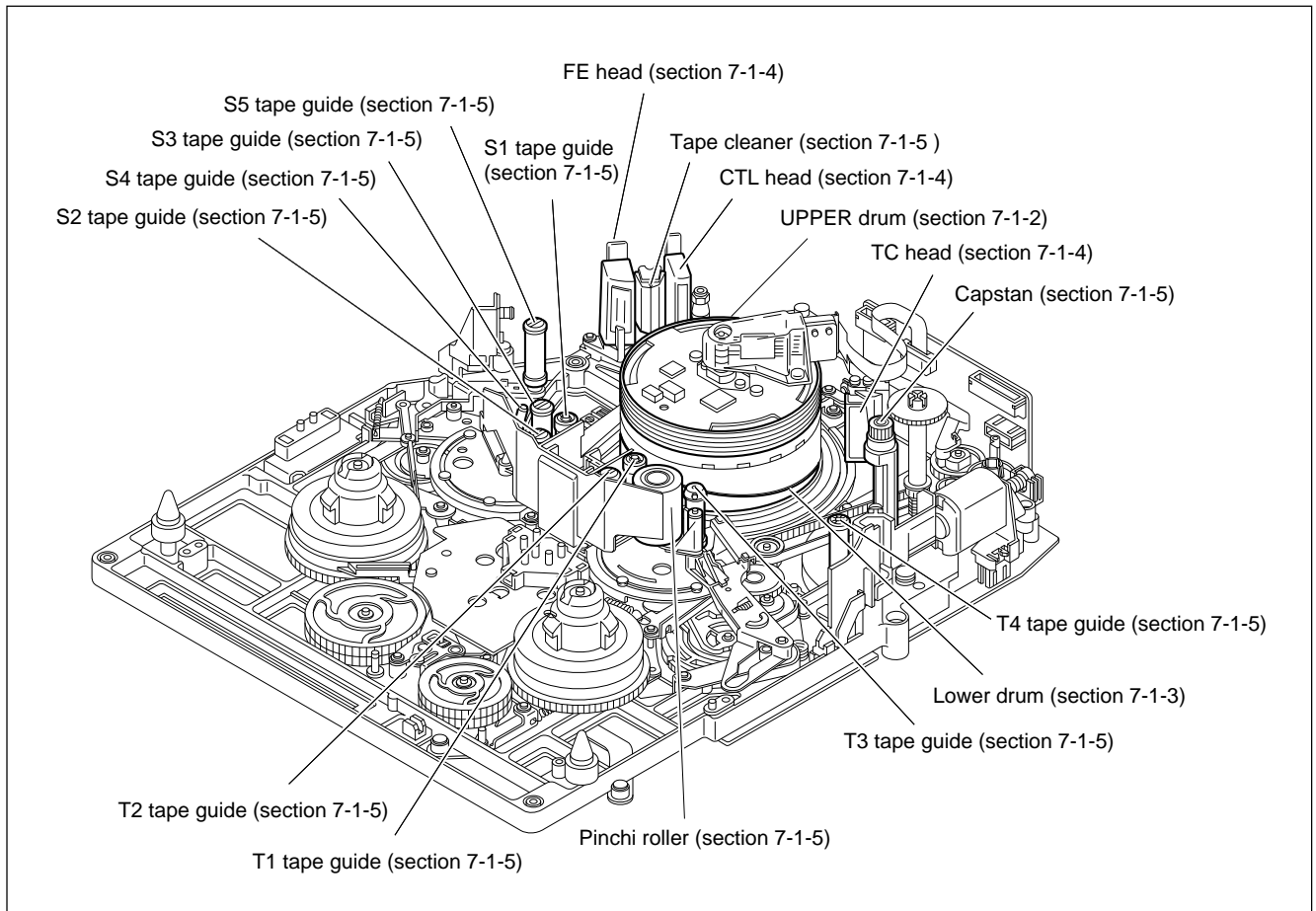

2. Notes on Cleaning

WARNING

Do not touch the rotating drum.

If you touch the drum with hand or screwdriver, it is danger to get hurt by the rapidly spinning drum.

- Make sure that the rotating drum completely stops before cleaning or replacement of parts.
- Do not touch the rotating drum during adjusting.

- Be sure to turn the power off before cleaning.
- The blocks in the mechanical deck consist of the precision parts, and are aligned precisely. Be careful not to damage the parts, and not to apply an excessive force during cleaning.
- Do not touch the greased portions during cleaning. If grease attaches to a cleaning cloth, replace the cleaning cloth with a new one. A grease-smearred cleaning cloth may make portions where it should not be, smeary.
- Do not insert a cassette tape before cleaning fluid completely evaporates.

3. Preparations

- (1) Turn the power off.
- (2) Remove the front lid and the outside panel. (Refer to section 1-5.)

7-1-2. Cleaning of Tape Running Surface of Upper Drum and Video Heads

Note

The upper drum and video heads are the parts that can damage easily. Take a great care not to damage the upper drum and rotary heads during cleaning.

Tools Required

- Cleaning cloth : 3-184-527-01
- Cleaning fluid : 9-919-573-01

Note

Never use a cotton swab.

Procedures

1. Press the cleaning cloth moistened with cleaning fluid slightly against the position of the rotary heads installation height. Keep the cleaning cloth from contact with the rotary heads this time.

Note

Never press the cleaning cloth with wrinkle to the video head during cleaning.

2. Rotate the upper drum slowly in the counterclockwise direction by hand and clean it.

Note

Be sure to rotate the upper drum counterclockwise. (Do not clean the video heads in the vertical direction. This may damage them.)

3. After cleaning, wipe the rotary heads using a dry cleaning cloth.

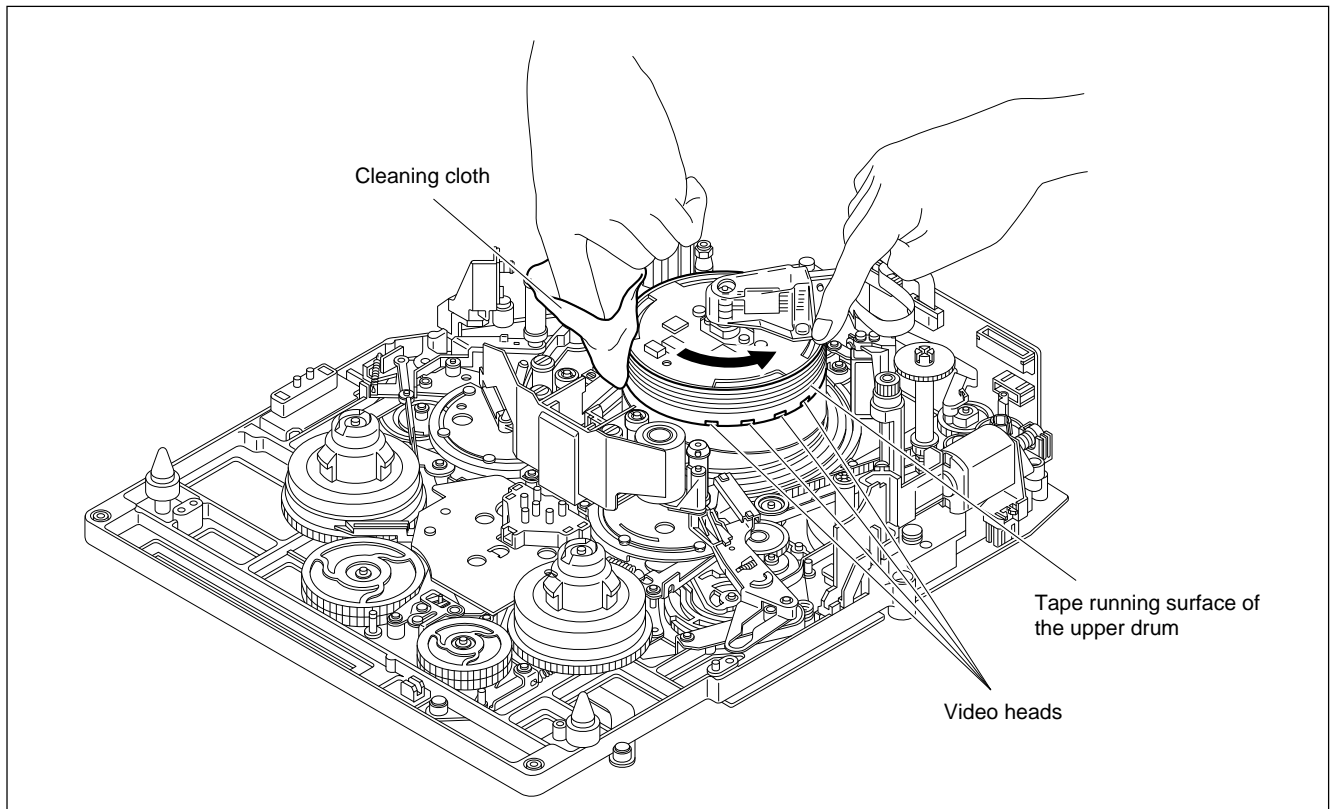

7-1-3. Cleaning of Tape Running Surface of Lower Drum and Lead Surface

Notes

Take care not to damage the lower drum (specially lead surface) during cleaning. Take care to clean the edge portion above the lower drum because it is near the video heads.

Tools Required

- Cleaning cloth : 3-184-527-01
- Cleaning fluid : 9-919-573-01
- Skewer or an equivalent (Do not use a metallic skewer.)

Procedures

1. Put a skewer (or an equivalent) along the drum lead surface and remove magnetic powder as shown in the figure.

Notes

- (a) Do not use a metallic skewer instead of a skewer. This may damage the tape running surface.
 - (b) If the magnetic powder attached to the drum lead surface, tracking may badly influence. Remove the magnetic powder completely.
2. Clean the tape running surface of the lower drum and lead surface (shaded portion) using a cleaning cloth moistened with cleaning fluid as shown in the figure.
 3. After cleaning, be sure to wipe the tape running surface of the lower drum and lead surface using a dry cleaning cloth.

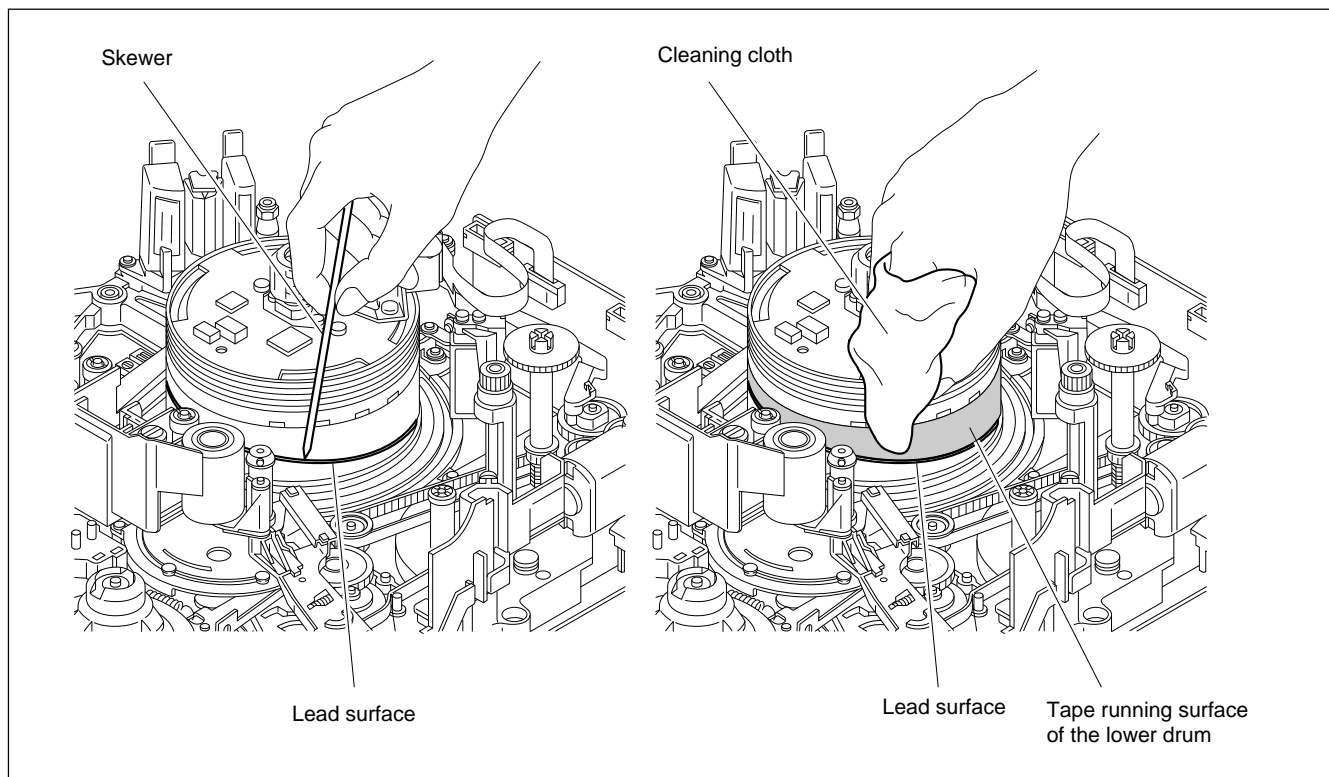

7-1-4. Stationary Heads Cleaning

CAUTION

Tape cleaner between the FE and CTL heads has a sharp edge. Never touch the edge by bare hands. Take care during cleaning.

Note

Take care not to damage the surfaces of the stationary heads during cleaning.

Tools Required

- Cleaning cloth : 3-184-527-01
- Cleaning fluid : 9-919-573-01

Procedures

1. Clean the tape running surfaces of the FE, CTL and TC heads in the vertical direction using a cleaning cloth moistened with cleaning fluid.

Note

If the magnetic powder attached to the head gap portions of the FE, CTL and TC heads, an error may occur during recording or playback. Remove the magnetic powder completely.

2. After cleaning, be sure to wipe the tape running surfaces of the FE, CTL and TC heads using a dry cleaning cloth.

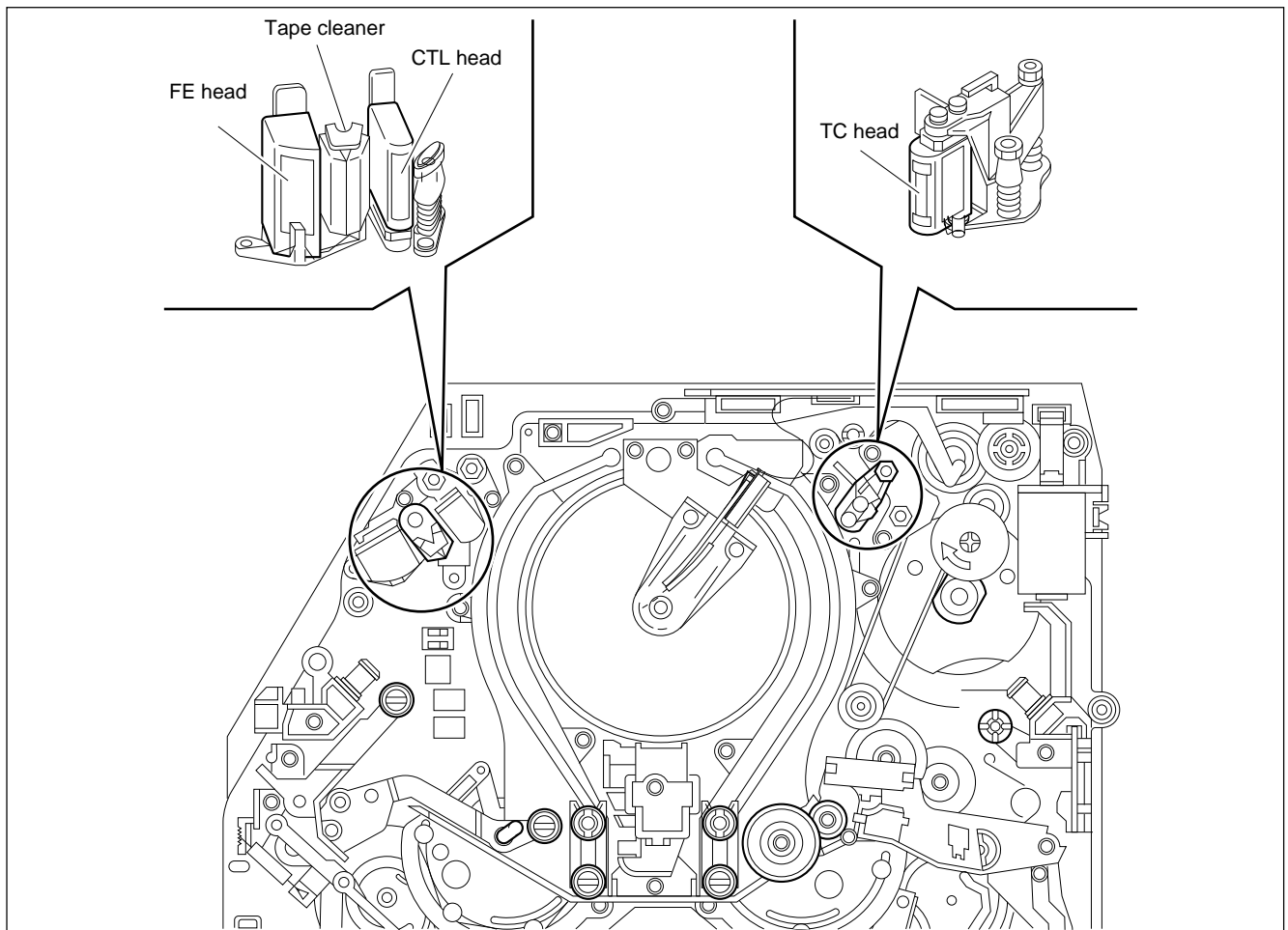

7-1-5. Cleaning of Tape Running System and Tape Cleaner

CAUTION

Tape cleaner has a sharp edge. Never touch the edge by bare hands. Take care during cleaning.

Tools Required

- Cleaning cloth : 3-184-527-01
- Cleaning fluid : 9-919-573-01

Procedures

1. Clean the tape running surfaces (shaded portions) of the following guides using a cleaning cloth moistened with a cleaning fluid as shown in the figure.

S1 guide, S2 guide, S3 guide, S4 guide, S5 guide, T1 guide, T2 guide, T3 guide, T4 guide, capstan and pinch roller.

2. After cleaning, be sure to clean it with a dry cleaning cloth two or three times.
3. Pass a piece of paper approximately this manual's paper thin through the clearance of the tape cleaner from top to bottom four or five times.
At this time, do not move the paper from bottom to top.

CAUTION

Never touch the edge portion of the tape cleaner by bare hands.

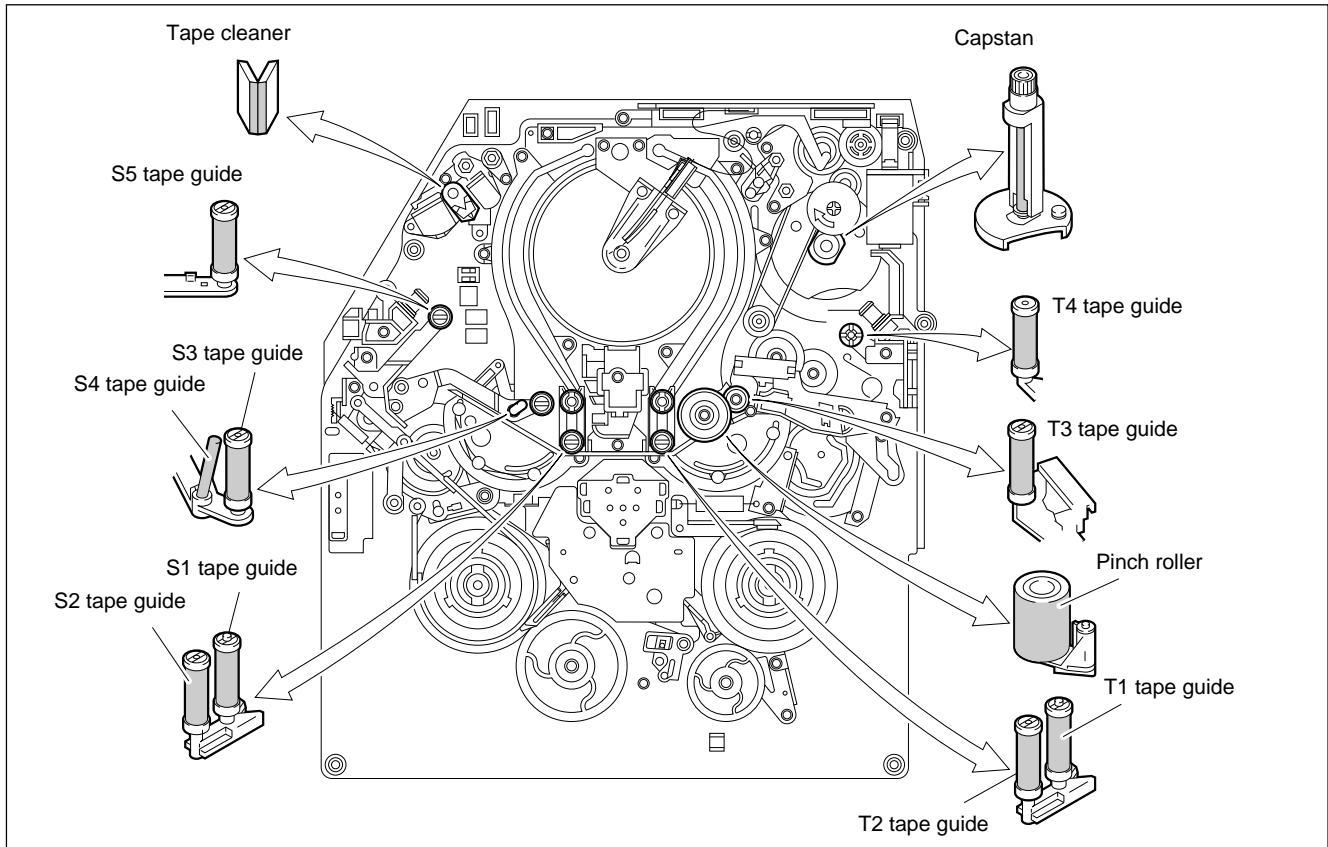

7-2. Periodic Check

To make the most of the functions, deliver the full performances of the unit, and to lengthen the life of the unit and tape, a periodic check is recommended.

7-2-1. Hours Meter

This unit can display an hours meter on the LCD display, and reset the your requested hours meter. It is recommendable to carry out the periodic check using this hours meter as a reference.

1. Display procedures

- (1) Press the DIAGNOSTIC switch on the side panel to enter the DIAGNOSTIC mode using the tip of a clip.
- (2) The LCD display changes every time you press the SHIFT button on the side panel.
- (3) Press the DIAGNOSTIC switch on the side panel to exit the DIAGNOSTIC mode.

2. Customer reset

The hours meters of “5. DRUM RUN-2”, “6. TAPE RUN-2”, “7. OPERATION-2” and “8. THREADING-2” can be reset by a customer.

- (1) While checking on the LCD display, select the hours meter to be reset by pressing the SHIFT button on the side panel.
- (2) Press the RESET button on the side panel, and the total time of the selected hours meter will be reset.

3. Contents of display

Mode	Description
LCD display (Blinking)	
01 XXXH	1. Total hours of drum rotating (Display of the time by an hour)
02 XXXH	2. Total hours of tape running (Display of the time by an hour)
03 XXXH	3. Total power-on time of the unit (Display of the time by an hour)
04 XXX	4. Total number of threading (Display of the threading and unthreading times)
05 XXXH	5. Drum rotating hour (Customer-resetable)
06 XXXH	6. Tape running hour (Customer-resetable)
07 XXXH	7. Power-on time of the unit (Customer-resetable)
08 XXX	8. The number of threading (Customer-resetable)

7-2-2. Periodic Check List

Replacement time shown in the following list is not the guarantee term parts. Use this list as guidelines for the maintenance and inspection. The replacement time of the parts varies depending on the operation environment and conditions of the unit.

Note

The parts marked with “↓” will be replaced at the same time when the part pointed by “↓” is replaced. As for replacement procedures for the parts shown in the table, refer to the maintenance manual Part2 Volume1, Section3.

Mode A : Drum running hour

Mode B : Tape running hour

No.	Item	Mode	Inspection hours (h)			Replacement parts	
			2000	4000	6000	Part name	Part No.
1	Upper drum	A	R	R	↓	Upper drum assy DJR-15-R	A-8311-299-
2	Slip ring	A	R	R	↓	Slip ring assy (RP)	A-8311-292-
3	Brush for slip ring	A	R	R	↓	Brush assy (RP)	A-8311-293-
4	Drum	A	—	—	R	Drum assy DJH-15A-R	A-8311-298-
5	VH cleaner	A	R	R	R	VH cleaner assy	A-8278-366-
6	Tension regulator band	B	—	R	—	Tension regulator band assy	X-3678-683-
7	Reel drive gear	B	—	R	—	Reel drive gear assy	A-8278-365-
8	Pinch roller	B	R	R	R	Pinch roller assy	X-3678-926-

The “R” mark in this table indicates the replacement timing of parts.

- Check sometimes the deformation of the eye cap of the viewfinder, and the reduction of the emission current of the CRT. Replace them as necessary.
- Replace the lithium battery on the TC-80 board every five years.

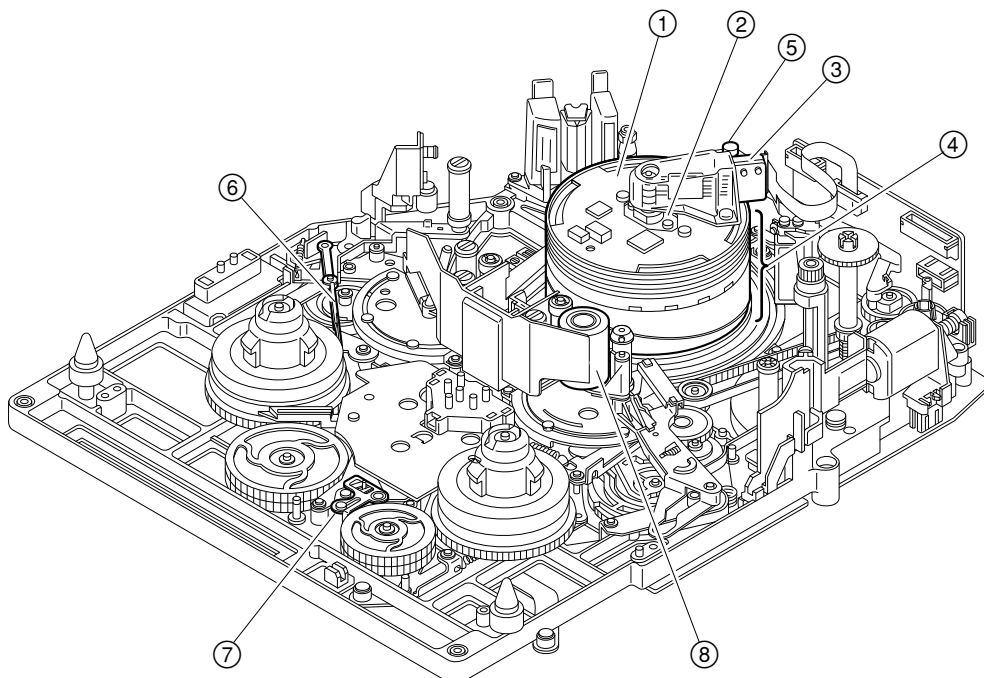

7-3. Cares After Using at Special Environment

It is recommended to check the following items after gathering the news at seaside or dust area.

1. Clean off sand and other dust in the unit carefully.
2. Clean the video heads, upper and lower drums and stationary heads.
3. Clean the tape running surfaces (tape guides, capstan shaft and pinch roller).
4. Clean the connectors on the connector panel.
5. Carry out the common operation check (recording or playback) and check that the unit has not an abnormal sound or operation.

If the unit has an abnormal condition, please contact your Sony dealer.

このマニュアルに記載されている事柄の著作権は当社にあり、説明内容は機器購入者の使用を目的としています。

従って、当社の許可なしに無断で複製したり、説明内容(操作、保守等)と異なる目的で本マニュアルを使用することを禁止します。

The material contained in this manual consists of information that is the property of Sony Corporation and is intended solely for use by the purchasers of the equipment described in this manual.

Sony Corporation expressly prohibits the duplication of any portion of this manual or the use thereof for any purpose other than the operation or maintenance of the equipment described in this manual without the express written permission of Sony Corporation.

Le matériel contenu dans ce manuel consiste en informations qui sont la propriété de Sony Corporation et sont destinées exclusivement à l'usage des acquéreurs de l'équipement décrit dans ce manuel.

Sony Corporation interdit formellement la copie de quelque partie que ce soit de ce manuel ou son emploi pour tout autre but que des opérations ou entretiens de l'équipement à moins d'une permission écrite de Sony Corporation.

Das in dieser Anleitung enthaltene Material besteht aus Informationen, die Eigentum der Sony Corporation sind, und ausschließlich zum Gebrauch durch den Käufer der in dieser Anleitung beschriebenen Ausrüstung bestimmt sind.

Die Sony Corporation untersagt ausdrücklich die Vervielfältigung jeglicher Teile dieser Anleitung oder den Gebrauch derselben für irgendeinen anderen Zweck als die Bedienung oder Wartung der in dieser Anleitung beschriebenen Ausrüstung ohne ausdrückliche schriftliche Erlaubnis der Sony Corporation.

DNW-90WSP (SY)
DNW-90WS (SY)
DNW-90P (SY)
DNW-90 (SY)
DNW-9WSP (SY)
DNW-9WS (SY)
DNW-7P (SY)
DNW-7 (SY) E
3-191-542-04

Sony Corporation
Broadcast Products Company

Printed in Japan
1997. 12 08
©1996

Published by Broadcast Products Company