

# SONY

COMMUNICATION CAMERA MODULE

## *EVI-R10/R11*

## *R50/R51*

Component/OEM



- High-Quality Picture using DSP
- Multi-Purpose Color Camera for Communication
- Elastic Arm
- Close up to 10mm
- Microphone included
- Adjustable Focus, Adjustable Iris Lens
- AC Adapter, AV Cable Supplied

# SPECIFICATIONS

	EVI-R10(NTSC)	EVI-R11(PAL)	EVI-R50(NTSC)	EVI-R51(PAL)
Image Sensor	1/4" Hyper HAD Color CCD			
Effective Pixels	510(H)×494(V)	500(H)×582(V)	510(H)×494(V)	500(H)×582(V)
H. Resolution	more than 300TV lines			
Lens	f=3.9mm, F=1.8, 10mm to ∞			
H. Angle of View	50°			
S/N Ratio	more than 46dB			
Focus	Manual			
Iris	Manual			
White Balance	Auto			
Electronic Shutter	1/60/1/100sec.	1/50sec.	1/60/1/100sec.	1/50sec.
Video Out (75Ω Termination)	Y:VS1.0Vp-p sync negative C:Burst 0.286Vp-p VBS:1.0Vp-p Composite	Y:VS1.0Vp-p sync negative C:Burst 0.300Vp-p VBS:1.0Vp-p Composite	Y:VS1.0Vp-p sync negative C:Burst 0.286Vp-p VBS:1.0Vp-p Composite	Y:VS1.0Vp-p sync negative C:Burst 0.300Vp-p VBS:1.0Vp-p Composite
Audio Out	-10dBs 245m Vrms, 10kΩ, Monaural			
Min. illumination	9lx/F1.8			
Power Requirement	DC6.0V, 1.8W			
Dimensions(W/H/D)	Body 93×43×134mm Camera Head 25×22×73mm Arm 248mm		Body 93×43×134mm Camera Head 25×22×73mm Arm 500mm	
Weight	650g		700g	
Supplied Accessory	AC Adapter, AV Cable			

# CONNECTION

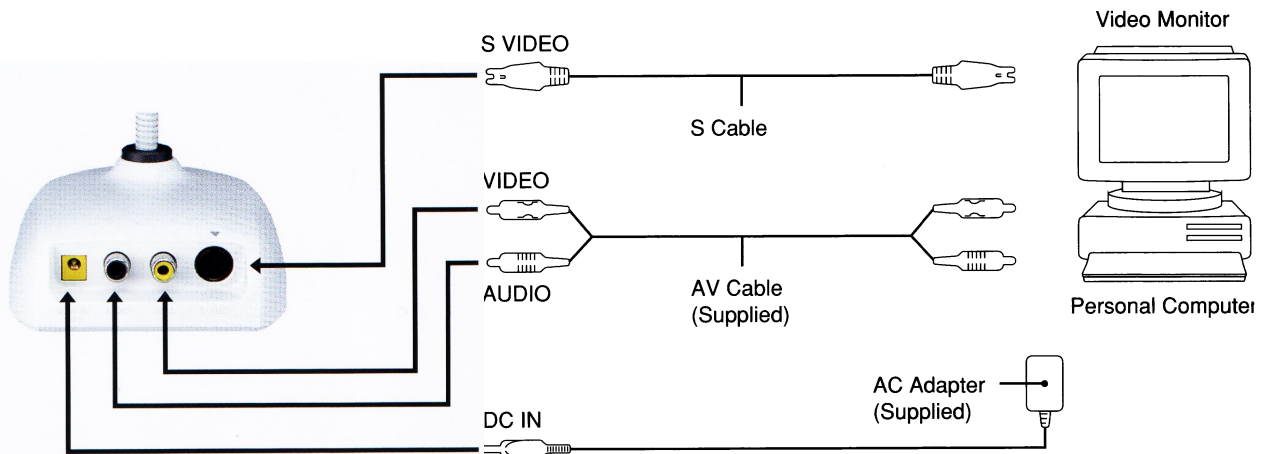

# DEMENSIONS

**EVI-R10/R11**

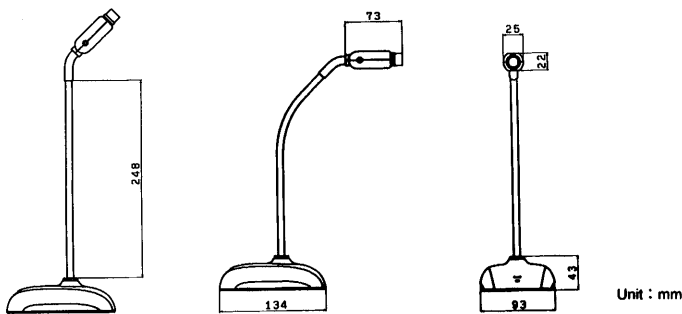

**EVI-R50/R51**

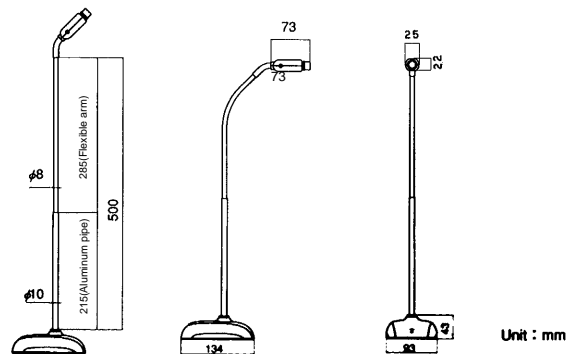

- Sony Electronics Inc. (USA) HQ
- Sony of Canada Ltd. (CANADA)
- Sony Broadcast & Professional Europe HQ

Germany  
France  
UK  
Nordic  
Italy

- 1 Sony Drive Park Ridge, NJ 07656
- 411 Gordon Baker Road, Willowdale, Ontario M2H 2S6
- 15, rue Floreal 75831 Paris Cedex 17, France
- Hugo-Eckener-Str. 20, 50829 Koln
- 15, rue Floreal 75831 Paris Cedex 17
- The Heights, Brooklands, Weybridge, Surrey KT13 0XW
- Per Albin Hanssons vag 20 S-214 32 Malmo Sweden
- Via Galileo Galilei 40 I-20092 Cinisello Balsamo, Milano

- (TEL:+1-201-930-7451) (FAX:+1-201-358-4401)
- <http://www.sony.com/professional>
- (TEL:+1-416-499-1414) (FAX:+1-416-497-1774)
- (TEL:+33-1-40-87-35-11) (FAX:+33-1-40-87-35-17)
- <http://www.bpe.sony-europe.com>
- (TEL:+49-221-5966-322) (FAX:+49-221-5966-491)
- (TEL:+33-1-49-45-41-62) (FAX:+33-1-47-31-13-57)
- (TEL:+44-990-331122) (FAX:+44-1932-817011)
- (TEL:+46-40-190-800) (FAX:+46-40-190-450)
- (TEL:+39-2-618-38-431) (FAX:+39-2-618-38-402)

- Sony Corp. B&P Systems Co. ISP Dpt. (JAPAN)

4-16-1 Okata, Atsugi-shi, Kanagawa-Ken, 243-0021

(TEL:+81-462-27-2345) (FAX:+81-462-27-2347)