

SONY[®]

Digital Video Camera
DXC-D35/D35P

Digital Video Camera
DXC-D35WS/D35WSP



The DXC-D35/D35WS Series* is a digital video camera designed as the top-end model for video professionals. With Sony's unique DSP (Digital Signal Processing) technology based on Sony's TruEye™ process and Sony's Power HAD™ CCDs, the DXC-D35/D35WS offers faithful color reproduction, similar to the human eye. By using the latest DSP circuits, pre-amplifier and encoding process, the detail expression and horizontal resolution are superior. Drastic smear reduction and high sensitivity, achieved with the Power HAD/Power HAD WS CCDs, provide more shooting opportunities, while maintaining superior picture quality.

The DXC-D35 is a powerful basic model, while the DXC-D35WS has additional features for shooting in

widescreen 16:9 aspect ratio as well as 4:3.

The DXC-D35/D35WS is dockable with a variety of on-board VTRs (DVCAM, Betacam SP, or Betacam SX formats) for camcorder operation. For remote control of the DXC-D35/D35WS, the new CCU-M5A/M5AP Multicore Camera Control Unit and the CCU-TX7/TX7P Triax Camera Control Unit are available. These systems will broaden the application of the DXC-D35/D35WS.

The DXC-D35/D35WS also provides a variety of automatic functions for operational convenience.

The DynaFit™ shoulder pad and the new DXF-801 Viewfinder also contribute to comfortable operation.

With all these features packed in its compact camera body, the DXC-D35/D35WS creates a new world of acquisition for a wide spectrum of applications.

** Hereafter, the DXC-D35 refers to both the DXC-D35 (NTSC model) and the DXC-D35P (PAL model).
The DXC-D35WS refers to the DXC-D35WS (NTSC model) and DXC-D35WSP (PAL model).*



DXC-D35/D35WS Features

The DXC-D35/D35WS incorporates state-of-the-art digital camera processing technology that is designed to fully exploit the benefits of DSP (Digital Signal Processing). The DXC-D35/D35WS has the following features.

Optimized Signal Processing with 10-bit A/D DSP LSI

The DXC-D35/D35WS includes the latest version of the Sony 10-bit analog-to-digital (A/D) DSP camera technology that delivers one of the best picture performances in the industry. Due to optimized signal processing, sharpness of the picture has been further improved. The DXC-D35/D35WS also incorporates innovative camera features such as TruEye and DynaLatitude™.

Natural Color Reproduction with the TruEye Process

Sony's TruEye digital signal processing technology virtually eliminates hue distortion, particularly obvious in extreme lighting conditions, that results from conventional RGB analog or digital processing. By processing video signal data at three levels - brightness, hue, and saturation - similar to how the human eye works, the TruEye process assists in the reproduction of natural skin tones.



TruEye ON



TruEye OFF

Contrast Control with the DynaLatitude Function

DynaLatitude, a unique feature for contrast control, minimizes video level distortion. Based on video signal histograms, the DynaLatitude function aligns the contrast of each pixel to eliminate imbalances such as the overexposure of background images.



DynaLatitude ON



DynaLatitude OFF

High Resolution with New Pre-amplifier and Encoding Circuit

In the DXC-D35/D35WS, pre-amplifier processing and digital-to-analog encoding are performed in a wide signal bandwidth range. This contributes to the high horizontal resolutions of 880 TV lines (DXC-D35) and 850/800 TV lines (4:3/16:9 modes of DXC-D35WS). Even without using detail control functions, the DXC-D35/D35WS delivers images in high resolution.

Enhanced Functions for Detail Correction

Because of Sony's DSP technology, the DXC-D35/D35WS is able to offer the following functions for detail correction:

- **Skin Detail Correction** to control skin detail simply by pressing the SKIN SET button
- **Black Halo-Free, Clean Detail** to maintain image sharpness in areas with extreme dark-to-light transitions
- **Red Vertical Detail Correction** to assure image sharpness of highly saturated subjects
- **Horizontal Detail Frequency Control**



Variable Color Temperature Setting

In addition to four built-in filters, the DXC-D35/D35WS has a function to adjust the color temperature by small steps. When the filter is set to 3200 K, color temperature can be chosen from 19 steps in the range from 2200 K to 4300 K using the viewfinder menu. Similarly, 13 steps in the range from 4600 K to 12000 K are provided when the filter is set to 5600 K. The set color can be recalled with the filter position. With this function, color correction required in a mixed color temperature environment and artistic painting such as adding a "sunset-like" effect can be easily performed without any special equipment.



Hyper Gain (42 dB)

Hyper Gain is a useful function that allows shooting in low light by boosting the electric gain. With the DXC-D35/D35WS, the gain level of Hyper Gain can be set to a maximum of 42 dB using the viewfinder menu system. This allows shooting in as low as 0.25 lx. Simply flipping the HYPER GAIN switch turns on this function.



0 dB



18 dB



Hyper Gain 36 dB



Hyper Gain 42 dB

DynaFit Shoulder Pad

The DXC-D35/D35WS is equipped with a DynaFit shoulder pad that molds to any shoulder without slipping and maintains excellent balance, free of painful pressure points common to harder shoulder pads.

DXF-801 Viewfinder

The DXF-801 is a new 1.5-inch Black/White viewfinder supplied with the DXC-D35/D35WS.

The following are the features of the DXF-801:

- Automatic switching of scanning size between 16:9 and 4:3
- VF light (LED) to light up the iris ring area of the lens for operation in dark situations (high/low/off)
- DISPLAY switch to turn off the character superimposition on the viewfinder
- Vertical and horizontal detail level control by PEAKING potentiometer
- Tally lamp levels (high/low/off)
- Two red REC tally lamps
- TAKE tally lamp for ClipLink™ operation or for a second tally lamp for CCU operations
- Diecast aluminum body
- Wide range of diopter adjustments



DXF-801 Viewfinder



Viewfinder Light

Enhanced Ease of Operation

Responding to the increasing demands for more automatic functions in professional level cameras, the DXC-D35/D35WS boasts several new and improved functions sure to please the most demanding camera operator.

- **EZ Focus** to make manual focusing easier
- **EZ Mode** to set the camera to a standard position instantly
- **Auto Tracing White Balance (ATW)** to adjust white balance in real time

File Operation for Image Creation

- **Camera Setup Files** consisting of a standard file, five factory preset files, and three user files
- **SetupNavi™ Function** to store the User Files and Factory Preset Files to the VAUX (Video Auxiliary) portion of a DVCAM tape
- **Scene File** operation by RCP-TX7
- **File Management** by PC via REMOTE connector (10-pin, RS-232C)

Convenient Features

- **Monitor Out (BNC connector)** to check the image in the viewfinder with a connected external monitor
- **Adjustable Black Stretch and Compress**
- **Dual Zebra** two types of zebra patterns
- **Programmable Gain**
- **Clear Scan™ (CLS)**
- **Date & Time Superimposition**
- **Built-in 1 kHz Audio Reference**
- **SMPTE (NTSC only)/SNG Color Bars**
- **Self Diagnostics**

Differences between the DXC-D35 and DXC-D35WS

The DXC-D35 and the DXC-D35WS share the same core technology. The DXC-D35 is a powerful basic camera to satisfy the requirements for high picture quality as well as the system versatility within a limited budget. The DXC-D35WS is a 16:9/4:3 switchable camera to respond to the demands for widescreen 16:9 acquisition.

Power HAD CCD (DXC-D35)

The DXC-D35 incorporates three Power HAD CCD sensors. These sensors feature a negligible vertical smear equivalent to conventional FIT CCDs, which addresses the tough demands of the high-end production field. The total performance of the Power HAD CCD sensor approaches that of the standard FIT. High sensitivity, high signal-to-noise ratio, and a virtually invisible vertical smear level of -125 dB are achieved.

Power HAD WS™ CCD (DXC-D35WS)

The DXC-D35WS is equipped with three newly developed 2/3-inch Power HAD WS CCDs with a high density of 520,000 pixels (NTSC)/ 620,000 pixels (PAL). Since the CCDs are designed for the 16:9 aspect ratio, with the capability to be switched to 4:3, high quality images can be obtained in the 16:9 mode without any image loss. High sensitivity, high signal-to-noise ratio, and a virtually invisible smear level of -120 dB are achieved.

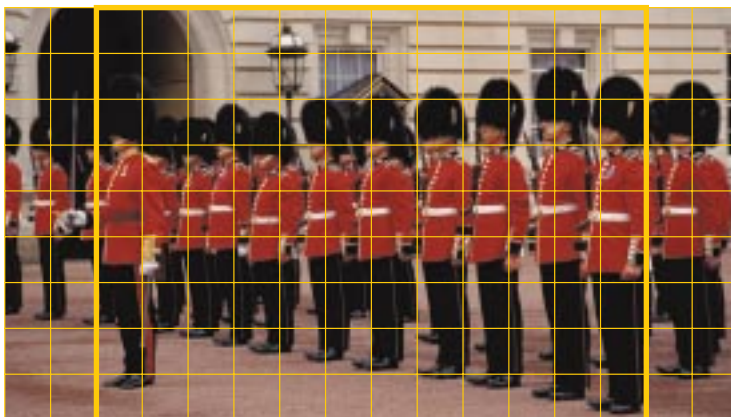

16:9 and 4:3 Switchable (DXC-D35WS)

The DXC-D35WS can operate in both widescreen 16:9 and standard 4:3 mode without any additional conversion equipment. Furthermore, when shooting in 16:9 mode, it is possible to display a safety zone marker (selectable from 15:9, 14:9, 13:9 and 4:3 aspect ratios) in the supplied viewfinder.

16:9 ID Pulse (DXC-D35WS)

When shooting 16:9 images, the DXC-D35WS automatically adds a wide aspect ID pulse signal to the video output signal from the camera VBS OUT, MONITOR OUT and 50-pin/76-pin interface, indicating that the picture is shot in 16:9 aspect ratio. With the proper video equipment, the aspect ratio is automatically switched to 16:9 by the ID pulse.

System Versatility



The DXC-D35/D35WS can be combined with a variety of camera adaptors and on-board analog or digital VTRs. This feature allows the DXC-D35/D35WS to work as a core product in various systems.

Multicore CCU Operation

With the CA-537/537P Camera Adaptor attached, the DXC-D35/D35WS can be remotely controlled from the CCU-M5A/M5AP Multicore Camera Control Unit with a CCZ-A cable (26-pin). The CCU-M5A/M5AP is useful when a camera remote control

system needs to be set up with an affordable budget. With the following features, the CCU-M5A/M5AP system can be used for a wide range of applications:

- 300 m cable compensation with CCZ-A cable (26-pin)
- Teleprompter support*
- Two composite outputs, one Y/C, and one component output (selectable from Y/R-Y/B-Y and R/G/B)
- Fan alarm LED
- Control functions
 - IRIS (auto/manual), White Balance (auto/manual/preset), Black Balance (auto/manual/preset), Gain Select (low/mid/high), R/B Gain, R/B Pedestal, Master Pedestal, Sub-carrier Phase, Horizontal Phase, Output Mode (color bar/camera), Knee Point (auto/manual/preset), Detail Level, Tally/Intercom, Shutter Speed Selection, Clear Scan



* For teleprompter application, a certain modification is required in some cases. Please contact your nearest Sony office.



Triax CCU Operation

With the CA-TX7/TX7P Triax Camera Adaptor attached, the DXC-D35/D35WS can be remotely controlled from the CCU-TX7/TX7P Triax Camera Control Unit. With the CCU-TX7/TX7P and a lightweight triax cable, a sophisticated remote control system is possible, even over a great distance.

- High quality analog component video transmission
- Wide bandwidth (10 MHz for Y and 4.5 MHz for R-Y/B-Y)
- Wide range of control functions for digital cameras
- Long distance transmission (ex. 1500 m via a Ø 14.5 mm cable)
- Smooth, real-time control and instant tactile response
- AC/DC operation
- Optional control panels (RCP-TX7, COU-TX7)
- SDI outputs (with optional DXBK-701)
- Two composite outputs, two component outputs (Y/R-Y/B-Y, R/G/B or Y/C)
- Two inputs for return video (BNC type)
- Teleprompter
- Major intercom system support (Four-wire/Two-wire/RTS/Clearcom)
- Program microphone system
- Two-channel microphone system (two XLR connectors)
- RS-232C port for multiple camera operation or connection to a computer



Remote Controllers

The 10-pin REMOTE Connector is designed in accordance with the RS-232C standard. With this connector, the DXC-D35/D35WS can be directly controlled from the compact RM-M7G or RCP-TX7.

As a DVCAM™ Camcorder (With DSR-1/1P)

The DXC-D35/D35WS can be docked with the DSR-1/1P DVCAM Recorder via the 76-pin Digital connector that supplies 4:2:2 10-bit component digital output from the camera to the recorder. Since the DXC-D35/D35WS is designed to be configured with the DSR-1/1P, some unique features are provided for the use as a DVCAM full digital camcorder.

- DVCAM digital recording format for professional use
- Playback compatibility with the consumer DV recording format
- Support of both DVCAM Mini Cassette tapes and DVCAM Standard Cassette tapes
- Maximum recording time — 184 minutes (DVCAM Standard Cassette tape)
- Maximum operating time — 260 minutes (BP-L90A Lithium-ion battery)
- Time code superimposition during playback
- Easy control of CH-1 audio level with level controller on the front panel
- Edit Search function to easily access to edit points
- Freeze Mix function to easily position the subject just as in the previous shot
- SetupNavi™ function to store camera setup files onto the Video Auxiliary portion of a DVCAM tape
- SetupLog™ to automatically record camera setting data for each shot onto VAUX portion of a DVCAM tape
- ClipLink System comprehensive shooting information and image management system

As a Betacam SP® Camcorder (With PVV-3/3P)

By combining the DXC-D35/D35WS with the PVV-3/3P Betacam SP Recorder, a Betacam SP camcorder can be configured. The high quality picture of the DXC-D35/D35WS Digital Video Camera can be directly recorded in the Betacam SP format - one of the best analog recording formats currently available in the professional field. The status information and data from the PVV-3/3P, such as time code, recording audio level, remaining battery power, and remaining time can be superimposed on the viewfinder.

As a Betacam SX™ Camcorder (With DNV-5/5P)

By combining the DXC-D35/D35WS with the DNV-5/5P Betacam SX Recorder via the CA-511 Camera Adaptor, an affordable Betacam SX digital camcorder can be configured. The high quality picture of the DXC-D35/D35WS can be directly recorded onto a Betacam SX Digital Video Cassette Tape, widely used for top-end production. Status information such as "low battery" and "tape near end" can be shown in the viewfinder.



System Configuration

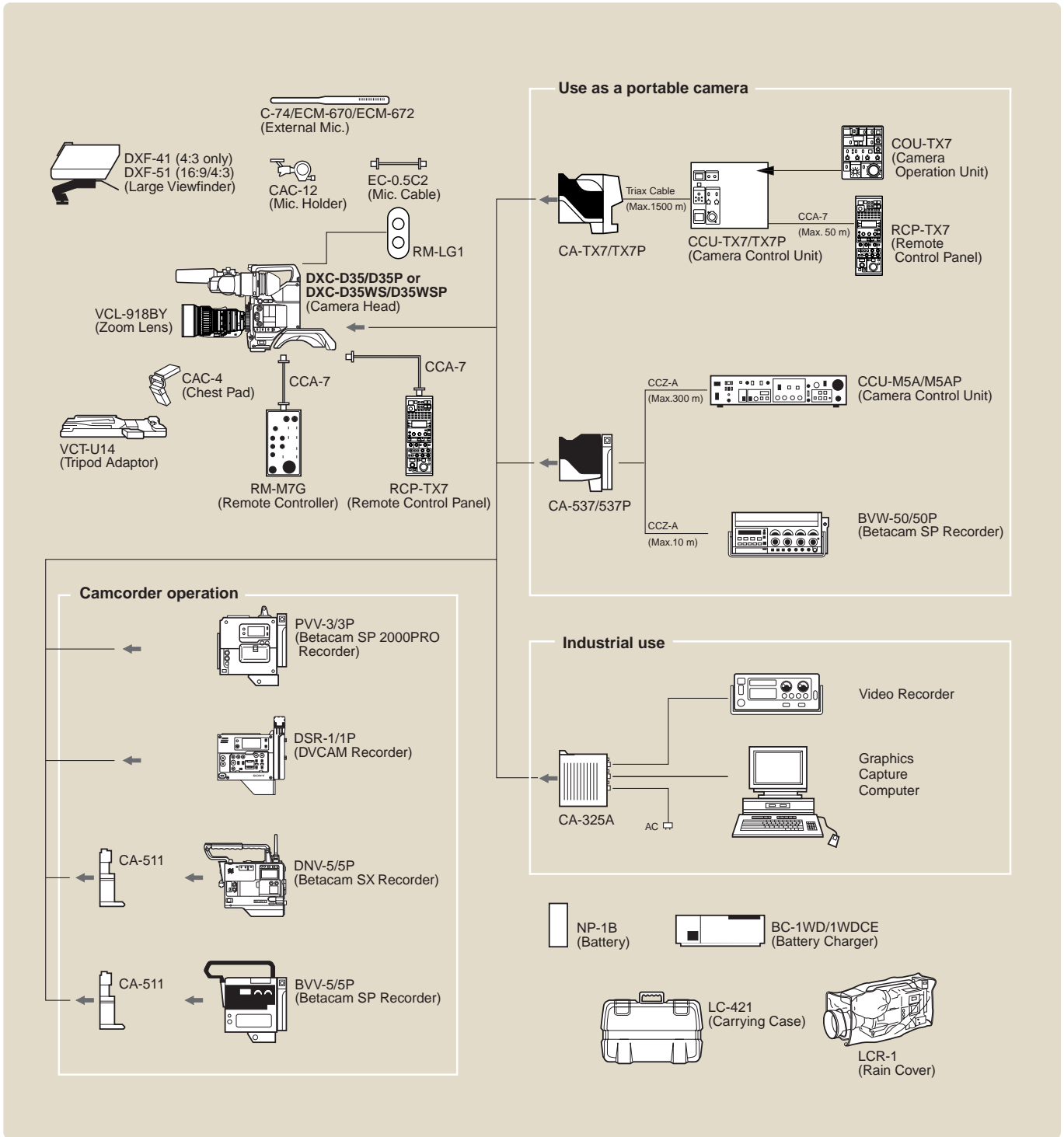

Product Configurations

| | DXC-D35K (NTSC) or DXC-D35PK (PAL) | DXC-D35L (NTSC) or DXC-D35PL (PAL) | DXC-D35H (NTSC) or DXC-D35PH (PAL) |
|---|---------------------------------------|---------------------------------------|---------------------------------------|
| DXC-D35 (NTSC) or DXC-D35P (PAL) Camera head | Yes | Yes | Yes |
| Camera handle* | Yes | Yes | Yes |
| Remote control unit RM-LG1* | Yes | Yes | Option |
| Viewfinder DXF-801* (with microphone holder) | Yes | Yes | Option |
| Tripod adapter VCT-U14 | Yes | Yes | Option |
| External microphone* | Yes | Yes | Option |
| Zoom lens | Yes | Option | Option |

| | DXC-D35WSL (NTSC) or DXC-D35WSPL (PAL) |
|---|--|
| DXC-D35WS (NTSC) or DXC-D35WSP (PAL) Camera head | Yes |
| Camera handle* | Yes |
| Remote control unit RM-LG1* | Yes |
| Viewfinder DXF-801* (with microphone holder) | Yes |
| Tripod adapter VCT-U14 | Yes |
| External microphone* | Yes |
| Zoom lens | Option |

| | DSR-135PL (PAL) |
|---|-----------------|
| Camera DXC-D35P (PAL) Camera head | Yes |
| DSR-1P (PAL) | Yes |
| Remote control unit RM-LG1* | Yes |
| Viewfinder DXF-801* (with microphone holder) | Yes |
| Tripod adapter VCT-U14 | Yes |
| External microphone* | Yes |
| Shoulder strap* | Yes |
| Handle for camcorder* | Yes |

* The camera handle, remote control unit, viewfinder, external microphone, shoulder strap and handle for camcorder are available only as service parts.

Optional Accessories



DSR-1/1P
DVCAM Digital Recorder



PVV-3/3P
Betacam SP 2000 PRO Recorder

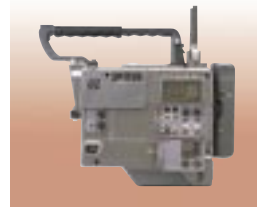

DNV-5/5P
Betacam SX Recorder



CCU-M5A/M5AP
Camera Control Unit



CCU-TX7/TX7P
Camera Control Unit



CA-TX7/TX7P
Camera Adaptor



RCP-TX7
Remote Control Panel for CCU-TX7



COU-TX7
Camera Control Unit for CCU-TX7

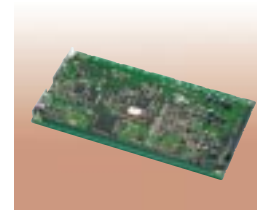

DXBK-701
SDI Output Board



RM-M7G
Remote Control Unit



CA-537/537P
Camera Adaptor



CA-325A/325AP
RGB Adaptor (AC operation)



CA-511
Camera Adaptor (for BVV-5 and DNV-5)

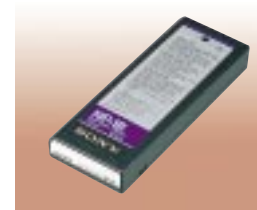

NP-1B
NiCd Rechargeable Battery



BP-L90A/L60A/L40A
Rechargeable Li-ion Battery Pack



BC-1WD/1WDCE
Battery Charger for up to four NP-1B



BC-410
Battery Charger for four BP-90A's and four NP-1B's



AC-DN1
AC Adaptor with Li-ion Battery Charger Capability



BKW-L601
Adaptor to attach BP-L60/L90 to dockable VTRs



BC-L100
Battery Charger for BP-L60A/L90A dockable VTRs



BC-L50
Battery Charger for BP-L90A/L60A/L40A



DC-L1
Battery Adaptor for charging NP-1B with BC-L100



CMA-8A/8ACE
AC Power Adaptor

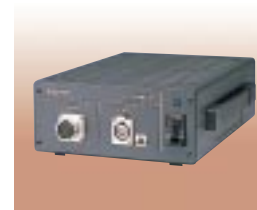

AC-550/550P
AC Power Adaptor

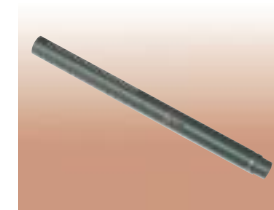

ECM-672
Electret Condenser Microphone

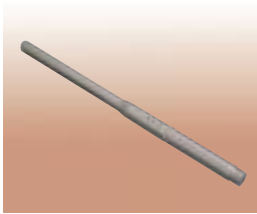

C-74
Condenser Microphone



EC-0.5C2
Microphone Cable



CAC-12
Microphone Holder



WRT-810A
UHF Wireless Microphone



WRT-820A
UHF Synthesized Transmitter



WRR-855A/810A*
UHF Synthesized Tuner
(For WRR-855A, BTA-801
Mount Adaptor is required)



DXF-41
4-inch Monochrome Viewfinder
4:3 only



DXF-51
5-inch Monochrome Viewfinder
16:9/4:3 Switchable



VCT-U14
Tripod Adaptor



DR-100
Intercommunication Headset



CCZ-A2/A5/A10
Connecting Cable (26-pin - 26-pin)



CCZQ-A2/A5/A10
Connecting Cable (26-pin - 14-pin)



LC-300SZ
Soft Carrying Case



LC-424
Hard Carrying Case

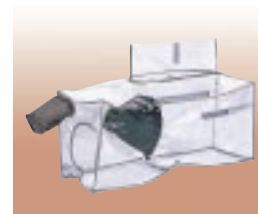

LCR-1
Rain Cover

Lenses



VCL-918BY



A17 x 9 BRM-28
(Fujinon)



A15 x 8 BERM-M28
(Fujinon)



VCL-916BYA



J16a x 8B
(Canon)



YJ18 x 9B
(Canon)

* WRR-855A/810A cannot be used in some areas.

Specifications

DXC-D35/D35P, DXC-D35WS/D35WSP Video Camera Head

| | |
|--|--|
| Image device: | 3-chip 2/3-inch, Interline-Transfer CCD |
| Optics: | F1.4 medium index prism system |
| Effective picture elements: (H x V) | DXC-D35: 768 x 494, DXC-D35P: 752 x 582 DXC-D35WS: 980 x 494, DXC-D35WSP: 980 x 582 |
| Total picture elements: (H x V) | DXC-D35: 811 x 508, DXC-D35P: 795 x 596 DXC-D35WS: 1038 x 504, DXC-D35WSP: 1038 x 594 |
| Sensing area: | DXC-D35/D35P: 6.6 mm x 8.8 mm DXC-D35WS/D35WSP: 9.6 mm x 5.4 mm |
| Built-in filters: | 1: 3200K, 2: 5600K+1/8ND, 3: 5600K, 4: 5600K+1/64ND |
| Lens mount: | Sony 2/3-inch Bayonet mount |
| Signal system: | DXC-D35/D35WS: NTSC color system DXC-D35P/D35WSP: PAL color system |
| Scanning system: | DXC-D35/D35WS: 2:1 interlaced, 525 lines, 60 fields/sec. DXC-D35P/D35WSP: 2:1 interlaced, 625 lines, 50 fields/sec. |
| Horizontal frequency: | DXC-D35/D35WS: 15.734 kHz DXC-D35P/D35WSP: 15.625 kHz |
| Vertical frequency: | DXC-D35/D35WS: 59.94 Hz DXC-D35P/D35WSP: 50 Hz |
| Sync system: | Internal and External with the VBS or BS signal |
| Horizontal resolution: | DXC-D35/D35P: 880TV lines DXC-D35WS/D35WSP: 850 TV lines (4:3 mode), 800TV lines (16:9 mode) |
| Vertical resolution: | DXC-D35/D35WS: 400TV lines (without EVS), 450TV lines (with EVS) DXC-D35P/D35WSP: 480TV lines (without EVS), 530TV lines (with EVS) |
| Minimum illumination: | 0.25 lx with F1.4, Hyper gain (36 dB+DPR*) 0.4 lx with F1.8, Hyper gain (36 dB+DPR*) |
| Sensitivity: | F11 at 2000 lx (3200 K, 89.9% reflectance) (typical) |
| Gain selection: | -3 dB, 0 dB, 3 dB, 6 dB, 9 dB, 12 dB, 18 dB, 18 dB+DPR, 24 dB, 24 dB+DPR, Hyper Gain (30 dB+DPR or 36 dB+DPR) |
| Shutter speed selection: | DXC-D35/D35WS: OFF, 1/100, 1/250, 1/500, 1/1000, 1/2000 sec DXC-D35P/D35WSP: OFF, 1/60, 1/250, 1/500, 1/1000, 1/2000 sec |
| Clear scan selection: | DXC-D35/D35WS: 60.4 to 200.3 Hz DXC-D35P/D35WSP: 50.3 to 201.4 Hz |
| Signal-to-noise ratio: | DXC-D35/D35WS: 63 dB (typical) DXC-D35P/D35WSP: 61 dB (typical) |
| Registration: | 0.05% (all zones, without lens) |
| Geometric distortion: | Below measurable level |
| Video output: | Camera head BNC connector VBS: 1.0Vp-p, sync negative 26-pin connector of CA-537/537P VBS: 1.0 Vp-p, sync negative Y/R-Y/B-Y: Y: 1.0 Vp-p negative, R-Y/B-Y: 700 mVp-p (DXC-D35/D35WS), 525 mVp-p (DXC-D35P/D35WSP) RGB: 1.4 Vp-p Y/C: Y: 1.0 Vp-p, sync negative, C: DXC-D35/D35WS: 286 mVp-p (burst level) DXC-D35P/D35WSP: 300 mVp-p (burst level) |
| Input/Output: | INTERFACE: Pro76-pin DIGITAL, Pro 50-pin VIDEO OUT: BNC MONITOR OUT: BNC LENS: 12-pin VF: DIN 8-pin, 20-pin REMOTE1: Stereo mini REMOTE2: 10-pin MIC IN: XLR 3-pin |

*Note: DPR is equivalent to +6 dB gain up.

| | |
|------------------------|--|
| Power requirements: | DC 12 V (10.5 to 17 V) |
| Power consumption: | DXC-D35/D35P: 12 W DXC-D35WS/D35WSP: 14.9 W |
| Operating temperature: | -10°C to 45°C (14°F to 113°F) |
| Storage temperature: | -20°C to 60°C (-4°F to 140°F) |
| Operating humidity: | Less than 85% |
| Storage humidity: | Less than 90% |
| Weight: | DXC-D35/D35P: Approx. 2.4 kg (5 lb, 5 oz) for camera head only DXC-D35WS/D35P: Approx. 2.5 kg (5 lb, 8 oz) for camera head only |
| Dimensions (w/h/d): | DXC-D35/D35P: 121 x 206 x 268 mm (4 7/8 x 8 1/8 x 10 5/8 inches) DXC-D35WS/D35WSP: 121 x 206 x 268 mm (9 5/8 x 8 1/8 x 10 5/8 inches) |

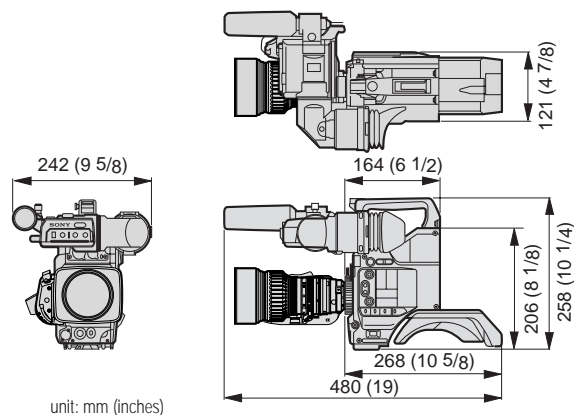

unit: mm (inches)

DSR-135P Camcorder for PAL

| | |
|------------------------|---|
| Power consumption: | 24.8 W |
| Operating temperature: | 0°C to 45°C (32°F to 113°F) |
| Storage temperature: | -20°C to 60°C (-4°F to 140°F) |
| Weight: | Approx. 6.3 kg (13 lb, 14 oz) including DXF-801, DSR-1P, handle, BP-L60A and joint plate |
| Dimensions (w/h/d): | 121 x 206 x 344 mm (4 7/8 x 8 1/8 x 13 5/8 inches) |

DXF-801

| | |
|------------------------|---|
| Picture tube: | 1.5-inch monochrome |
| Scan size: | 4:3 / 16:9 switchable |
| Indicators: | REC TALLY x 2, TAKE TALLY, BATT, SHUTTER, GAIN UP, |
| Horizontal resolution: | 600TV lines |
| Power requirement: | DC 12 V |
| Power consumption: | 2.1 W |
| Weight: | 620 g (1 lb 9 oz) |
| Dimensions (w/h/d): | 240 x 91 x 196 mm (9 1/2 x 3 5/8 x 7 3/4 inches) including protruding parts |

Distributed by

Sony Electronics Inc.
One Sony Drive
Park Ridge, NJ 07656