



SONY®



DISPLAY PRODUCT GUIDE

WHAT'S NEW



VPL-FE40
SXGA+

VPL-FX40
XGA

PAGE 12

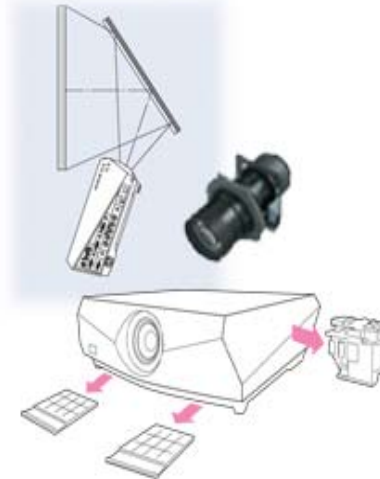

Visit www.3lcd.com
to learn more about
the new generation of
LCD projectors

BRAVIA PROFESSIONAL

KLHW-26

26" LCD accepts pro modules

PAGE 8

KLHW-32

32" LCD accepts pro modules



FWD PANEL WARRANTY

2 years

Labor & Parts -1 year on panel

PROJECTOR WARRANTY

3 years

Labor & Parts-3 years or
2500 hours on Optical Block,
90 days Lamp

WHAT'S INSIDE

Flat panel features	Page 2
<u>PLASMA PANELS:</u>	
FWD-50PX2	Page 3
FWD-42PX2	Page 3
FWD-42PV1	Page 4
<u>LCD PANELS:</u>	
FWD-40X2F	Page 4
FWD-32X2F	Page 5
KLHW32	Page 5
KLHW26	Page 5
Digital Signage Modules	Page 6-7 Page 8
<u>PROJECTORS:</u>	
VPL-FX52	Page 9-10
VPL-FX40 & FE40	Page 11
VPL-CX86	Page 12
VPL-CX63	Page 13
VPL-CX76	Page 14
VPL-CX61	Page 15
VPL-CS20 & CX20	Page 16
VPL-ES3 & EX3	Page 16
VPL-VW100	Page 17
VPL-VW50	Page 17
Lamps	Page 18
Projector Amplifiers	Page 18
Projection Screens	Page 19
Switchers, Interfaces & Lenses	Page 20
Mounts	Page 21

Flat Panel Features

INSTALL CONFIDENCE

Worry Free Service

What is the cost of going back to a job to replace or repair a problem flat panel? The Sony Worry Free Program makes a statement about the confidence you can have in Sony's build quality. Things typically don't go wrong, as with other brands. But if there is a problem, you have a 30 day exchange and on site service to cover you.

On Site Service

Under the ASC On Site Service program, qualifying products within the warranty period will be serviced On Site. Once the end user calls the 1-877-350-3477 number, they will locate a local service provider to come fix the unit on site. If product is not serviceable on site, the unit will be taken back to the local service location for repair. Most ASC locations are authorized to performed panel replacement.

NOTE: Any returned Plasma unit with Image Retention defect is subject to charge back to the customer for the panel repair or exchange cost.

30 Day return:

Under the 30 day rule, any qualifying product that fails within the first 30 days of purchase will be exchanged with new similar product. Customer must call Sony directly at **1-877-350-3477** to request the replacement unit. (END USER MUST NOT RETURN TO THE RESELLER OR DISTRIBUTOR)

True Color



TC² offers user control of saturation and the hue of either red, yellow, green, blue individually without changing other colors. White balance remains the same.

With this function, for example, the color of the corporate logo mark can be adjusted to its closest color.

Side panel cable concealment

The connectors on the side of the panel have swing away doors to provide cable concealment.



Accessory speakers



Network, Media & I/O Modules



BKMFW-32 – Int. Network Interface (FWD only)

BKMFW-50 – Network Media Interface

EBS-N200D – Ext. Network / Streaming Decoder

Includes 2GB Hard Drive for local content storage

NSP-1 Ext. Network Storage Player

ICSFW40 – HD Streaming Decoder

ICSFW40D – Includes 60Gb Hard drive for local content

EBS-SP10 – Ext. Cable TV tuner w/ VOD

EBS-SP15 – Hospitality System Programming Unit

EBS-SP35 – Ext. HD Tuner w/ VOD

ICS-SP20 – Int. Cable TV tuner w/ VOD

ICS-SP30 – Int. HD Cable Tuner w/ VOD

Video Wall Matrix

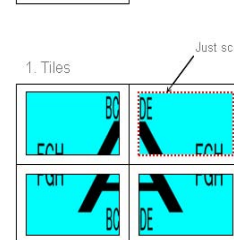

To show full signal on each displays.

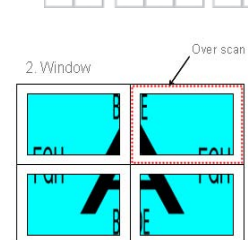

To show one large picture with multi display naturally. Part of the signal will go behind the bezel area.



Specifications & information are subject to change without notice.

Price and product updates found at
www.SonyPro.us

SONY® Flat Panel Displays - Plasma

FWD-50PX2B (flat black) & **FWD-50PX2S** (silver)
50" WXGA Plasma Panel Display



ACCESSORIES

PJNET Projector & Display Management Software
SPMTRI/C Clear Acrylic Base Table Stand
SPMTRI/E Silver Base Table Stand
SSSP50FW/S Silver speakers
SSSP50FW/B Black speakers
SEE MOUNTS ON PAGE 22
SEE MODULES ON PAGE 9



Features:

- WXGA 1366x768 Plasma Panel (aspect ratio 16:9)
- High Brightness and contrast 5000:1
- 60,000 Hours panel life
- Audio Output 7W x 2
- Inputs:
RGB/Component (HD-15), DVI-D HDCP,
Composite (BNC), S-Video, RS232
- Acceptable Video Signals:
NTSC, PAL, SECAM,
HDTV up to 1080i, 720p
- 49.4" x 29.6" x 4.37"
- VESA: N/A, see below for mounting options
- Net Weight: 95.5 lbs
- Picture in Picture and Picture and Picture
- Auto static image sense and protect
- Built-in Video wall mode up to 4x4
- Shipping Weight: 122 lbs

FWD-42PX2B (flat black) & **FWD-42PX2S** (silver)
42" WXGA Plasma Panel Display



ACCESSORIES

PJNET Projector & Display Management Software
SPMTRI/C Clear Acrylic Base Table Stand
SPMTRI/E Silver Base Table Stand
SSSP42FW/B Black speakers
SSSP42FW/S Silver speakers
SEE MOUNTS ON PAGE 22
SEE MODULES ON PAGE 9-11

Features:

- WXGA 1024 x 768 Progressive LCD Panel (aspect ratio 16:9)
- 60,000 Hours panel life
- 16 ms Response Time
- Contrast 10,000:1
- 1200 cd/m2 High Brightness Panel
- Anti-Glare, Anti-Reflective
- 170 degree H/V Viewing Angle
- Audio Output 14W x 2
- Low power consumption (330W)
- Inputs:
RGB/Component (HD-15), DVI-D HDCP, Composite (BNC),
S-Video, RS232
- Acceptable Video Signals:
NTSC, PAL, SECAM,
HDTV up to 1080i, 720p
- 40.7 x 24.9 x 4.77"
- VESA: N/A, see below for mounting options
- Mount Design — Landscape, Portrait
- Net Weight: approx. 66.1lbs
- Shipping Weight: 121 lbs



Specifications & information are subject to change without notice.

Price and product updates found at www.SonyPro.us

SONY® Flat Panel Displays - Plasma

FWD-42PV1B (flat black) & **FWD-42V1S** (silver)
& **FWD-42PV1P** (portrait model)
42" WVGA (852 X 480) Plasma Display Panel.



ACCESSORIES

PJNET Projector & Display Management Software
SPMTRI/C Clear Acrylic Base Table Stand
SPMTRI/E Silver Base Table Stand
SSSP42FW/S Silver speakers
SSSP42FW/B Black speakers
SEE MOUNTS ON PAGE 22
SEE MODULES ON PAGE 9



Features:

- Portrait and High Altitude models available.
- Ultra-high Brightness and Contrast 10,000:1
- 10 bit processing – 1.07 Billion Colors
- Long life rating of 60,000 hours.
- Built-in screen saver modes (inc. auto dimmer)
- Accepts SD and HD format to 1080i
- Dual 7W Stereo Amplifiers
- Video Inputs : Composite (BNC), Y/C, Component (HD15), Digital (DVI-D HDCP)
- Supports NTSC, PAL, SECAM
- Control Inputs: RS-232C, Control-S
- Audio In / Out : RCA (L/R), Stereo Mini X2
- Picture-in-Picture, Closed Caption Decoder
- Dual Option Slots
- Net Weight: 59.5 lbs.
- Shipping Weight: 83.8 lbs.
- 40.75" x 24.875" x 3.375"
- VESA Mount (see options below)

SONY® Flat Panel Displays - LCD

FWD-40LX2F (flat black) & **FWD-40LX2S** (silver)
40" WXGA LCD Panel Display



ACCESSORIES

PJNET Projector & Display Management Software
SPMTRI/C Clear Acrylic Base Table Stand
SPMTRI/E Silver Base Table Stand
SS-SP40FW/S Silver speakers
SS-SP40FW/B Black speakers
SEE MOUNTS ON PAGE 22
SEE MODULES ON PAGE 9

Features:

- WXGA 1366 x 768 Progressive LCD Panel (aspect ratio)
- 60,000 Hours panel life
- 10 ms Response Time
- PC resolution up to 1600 x 1200; HD up to 1080i
- 450cd/m2 High Brightness Panel
- 178 degree H/V Viewing Angle
- Pixel Pitch 648 x .648 mm
- Audio Output 7W x 2
- Inputs: RGB/Component (HD-15), HDMI, Composite (BNC), S-Video, RS232
- Acceptable Video Signals: NTSC, PAL, SECAM, HDTV-1080i, 720p
- 39 x 23.5 x 4.9"
- VESA: N/A, see below for mounting options
- Net Weight: 67.5 lbs
- Shipping Weight: 121 lbs



Specifications & information are subject to change without notice.

Price and product updates found at
www.SonyPro.us

SONY Flat Panel Displays - LCD

Picture

Model/Description

FWD-32LX12F (flat black) **FWD-32LX12S** (silver)
 32" WXGA LCD Panel Display



2 HDMI (1920x1080p)
 w/EDID will handle video &
 PC timings.

ACCESSORIES

PJNET Projector & Display Management Software
 SPMTRI/C Clear Acrylic Base Table Stand
 SPMTRI/E Silver Base Table Stand
 SSSP32FW/S Silver speakers
 SSSP32FW/B Black speakers
 SEE MOUNTS ON PAGE 22
 SEE MODULES ON PAGE 9

Features:

- WXGA 1366 x 768 Progressive LCD Panel (aspect ratio 16:9)
- 60,000 Hours panel life
- 8 ms Response Time
- PC resolution up to 1600 x 1200; HD up to 1080i
- 450cd/m2 High Brightness Panel
- 170 degree H/V Viewing Angle
- Audio Output 10W x 2
- Inputs:
 - RGB/Component (HD-15), HDMI Composite (BNC), YUV (Composite), RS232- ON INSTALLED CARD
- Acceptable Video Signals:
 - NTSC, PAL, SECAM, HDTV up to 1080i, 720p
- Network Management Adaptor option
- Picture modes: Custom (3), Vivid, Standard
- 31.6" x 19.4" x 4.2"
- 2 Expansion slots
- Net Weight: 38.5 lbs
- Shipping Weight: 20 lbs

KLH-W26 & KLH-W32
 1366 x 768 LCD Displays



Supplied Accessories:

- RM-YA004 Remote Control
- Tabletop Stand
- Batteries (Type AA) x2
- AC powercord
- Cable Holder
- Operating Instructions
- Warranty Card



- Expandable Card Slot : Supports ICS-SP30 HD videocard for key hotel VOD Pro:Idiom™ compliant. One slot can accomodate different sized option boards for video input, RS-232C Control S communication, and optional ICS and BKM.
- Hotel Setup Menu : Special setup menu allows access to unique features for hotels and is hidden from guests.
- Clone Setup Capability: Saves time when all hotel TV's need the same configuration.
- Built-in Speaker and removable table-top stand : Built in speaker and removable table-top stand eliminate the need for add on items.
- Small Footprint : Under Speaker design allows minimal width so HDTV can be placed in existing furniture.
- Multiple Inputs: HDMI x 2, PC (HD15) x1 , Additional inputs via optional ICS and BKM boards.
- Audio Stereo Minijack (x 1) Audio Power Output : 7W x 2
- VESA : Yes (200 x 100 hole pattern/ M4 thread size/ 14mm hole depth)
- Viewing Angle : Horizontal: 178°, Vertical: 178°
- Formats Supported : NTSC, PAL, SECAM, PAL-M, PAL-N, NTSC4.43, PAL60
- Contrast Ratio : 1300:1
- KLH-W32 Dimensions: 31.4" x 22.9" x 8.7" with stand;
 31.4" x 21.6" x 4.4" without stand
- KLH-W32 Weight : 36.6 lbs with stand
- KLH-W26 Dimensions: 26.1" x 19.9" x 8.7" with stand;
 26.1" x 18.6" x 4.1" without stand
- KLH-W26 Weight: 30 lbs. with stand



Specifications & information are subject to change without notice.

Price and product updates found at
www.SonyPro.us

SONY DIGITAL SIGNAGE MEDIA PLAYERS & CARDS

Picture

Model/Description

NSP-1



For Digital Signage installations on simple scale, the NSP-1, provides an end-to-end system software & hardware solution in one. The NSP-1 Network Player allows multiple, concurrent layers shown as templates and meets the requirements of being able to simultaneously playback HTML, Flash, MP3 and MPEG-2 or MPEG-4 video, text and graphic files file as foreground or background. The BZNP-D1LE software package is part of the bundled solution, to allow asset management, layout formatting and scheduling.



Sony's NSP-1 Network Player was designed to easily interface to Sony's complete inventory of displays. From small LCD's or CRT's, to large plasmas or LCD's, to even large screen projectors, Sony has prepared you for every instance of displays.

BKMFW-50

Automatic Timer Function

(starts with power on / stops with power off)

JPG / MPEG2 play lists with MP3 audio background

Stream from Network Server, or local playback

Audio Format(s) Supported: MP3

Network Protocol Support: TCP/IP

Analog Audio Output: Speakers (L/R) Optional

RS232 Control: 1

Software Operating System : Web-base Controlling Software: Web Page

Multimedia Playback : Streaming playback, local file playback, store files locally from server. Automatic start programmed by web page or remote commander. JPG slideshow with MP3 audio track. Remote PC presentation with VNC software

VideoDisplay Resolution : 1024 x 768

Key features: Play List, Time Table, No black screen insertion when JPEG image, changing on Slide Show, Support LX2 series, Support MPEG 480i and Auto detection of video, MPEG video format *iAuto/480i/480p/576p*j, Check CF Remaining Amount, Play, Contents under Sub-folders on Compact Flash Memory, Rename files on Compact Flash Memory, Background Music : Can be set as Folder basis Display Message at booting-up & player idle, On/Off, Slide Show > Interval time setting : add 20/30/40sec, BG Color

Dimensions Width: 5 3/8" Height: 15/16" Depth :3 3/4" Weight:10.6 oz



EBS-N200D

Advanced Playlist Management - Scheduled playlists and logging - Control hundreds of displays and N200D units with included software

Audio Formats Supported: MPEG2/1, MP@ML, MP3

Network Protocol Support: Internet: IP, TCP, UDP, ICMP, ARP, DHCP, HTTP, FTP, IGMP, RDP

Analog Audio Output: Speakers (L/R) Optional

RS232 Control: 1 (Side)

Display Resolution: 1600 x 1200

Formats Supported: JPEG, GIF, TIF, BMP, Web Browser Plugins

Dimensions: Width: 7.0" , Height: 2.0" , Depth: 7.0"

Weight : 2 lbs



Specifications & information are subject to change without notice.

Price and product updates found at www.SonyPro.us

SONY DIGITAL SIGNAGE MEDIA PLAYERS & CARDS

Picture

Model/Description



ICS-FW40 & ICS-FW40D

The ICS-FW40 supports real-time streaming from a centralized of High Definition MPEG4/2, H.264, and WM9. Streaming data may be either UDP or UDP multicast to reduce overall network requirements. The card also enables IP control of Sony displays via RS232 protocol clients. A complete Windows based API is available allowing software developers to create custom control applications or integrate to existing ones. One application of this API is the FW40 Commander application, which comes included with the HD Network Card. FW40 Commander provides a convenient way to manage 1000s of displays across a network. FW40 Commander provides advanced configuration, scheduling, grouping, playlist creation, and content management. The ICS-FW40D adds a 60GB hard drive for on-site playback versus streaming to the card.

Streaming content delivery : IP Based, real time decoding (20 Mbps) Multi format HD support : MPEG2, MPEG4, H.264, WM9HD Digital Audio surround sound support : 5 Channels IP based display control : RS232 Protocol FW40 Commander Software : Device Configuration: Grouping, Scheduling, Playlist Creation, Content Management Firmware Update Capability : In-circuit

Audio Format(s) Supported: MP3, PCM, AAC, Dolby Digital 5.1

Graphics Format(s) Supported: JPEG, TIF, GIF, PNG, BMP, HTML

Audio/Video Output(s): RGB internal, up to 1600 x1200

Ethernet Port: 10/100BASE-T

RS-232C internal

Ethernet Protocol: Internet IP, TCP, UDP, ICMP, ARP, DHCP, HTTP, FTP, IGMP



LocationFree

The LF-B20 can stream live video content, with excellent picture quality, through a building network or across the internet to remote devices. It features integrated 802.11 a/b/g wireless LAN capability. The LocationFree® Base Station, streams to PlayStation Portable System, Windows® PC, Mac (running OS X or later), a Windows® Mobile -powered cellular phone or a Location Free Box receiver.

LF-B20 use the AVC (advanced video coding) codec – also called the h.264 codec – for higher picture quality even at lower bit rates. Switchable Dual Transmission Mode: MPEG2 and MPEG4 AVC. Requires 256 kbps download/uplink speed.

A new model, the LocationFree® Box (available summer 2007) enables you to view the content being served by your LocationFree® Base Station. Built-in Wireless 802.11.a/b/g . On-screen remote control. High picture quality MPEG4-AVC Codec.



Specifications & information are subject to change without notice.

Price and product updates found at
www.SonyPro.us

SONY I/O - NETWORK MANAGEMENT - HOSPITALITY CARDS

Picture

Model/Description



BKMFW11 Component/RGB input board



BKMFW12 RGB/Component active loop through

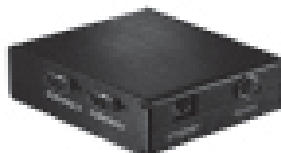

EBSN100 External network management device



BKMFW32 Internal network management device

Network management device provides display asset status and control over IP. Ideal for corporate, education and government applications where you have installs in multiple locations. From a central location IT managers can use Display Commander or PJNet™ Software to set and schedule on/off tasks, confirm hours of use, detect equipment malfunction and determine security status. Network Protocol Support : Internet: IP, TCP, UDP, ICMP, ARP, DHCP, HTTP, FTP, IGMP Internal Device Support: Plasmas: 42V1, 42X1, 50PX1; Control: Web Page, PJNET, Display Commander, Interfaces: LAN: 10/100BASE-T, via RJ-45, RS232: DB-9



EBSSP10 External TV Tuner & Hospitality device- Supports TV Cable applications and Video On Demand Networks (On Command, LodgeNet®, Hospitality Network and others), RS232 Control, 181 Channel CATV Tuner, Internal Picture & Picture capability, Video Output: RGB, Component Weight: 8 lbs Dimensions: 15/16 x 7 15/16 x 4 1/4"



ICSSP20 Internal VOD TV Tuner Card with Hotel Networking For FWD series

ICSSP30 Internal VOD TV Tuner with Hotel Networking For KHL series

181 Channel (Antenna and CATV), Closed Captioning, V-Chip Program Lockout, Parental Guidance (Channel Lock and Game Guard), Auto Programmable Scan RF Connection Inputs: (75 Ohms) NTSC, ATSC, QAM Inputs: S-Video, Composite, One Analog Audio Input: 3.5mm minijack (shared between Composite and S-Video), Data Port: RJ12 - MTI Port, Control-S Input, Audio Output: One Analog Audio 3.5mm minijack (line level out) Digital Audio- SPID Digital Audio (5.1 Surround) Screen Modes (16:9), Letterbox Screen Modes (4:3)



ESP-SP35 Formats Supported: MPEG-2 (layer 1 & 2), AC-3, MP3 (MPEG-1 layer 3)*, LPCM* / PCM* / AAC* (19 Mbps Maximum data rate) RF Connection Input(s) : (75 Ohms) NTSC, ATSC, QAM DC-In : 12v Data Port : RJ12 - MTI Port HDMI™ Connection Output(s) : 1 (one) Analog Audio Output(s) : L/R RCA Jack Digital Audio Output(s) : SPID Digital Audio (5.1 Surround) Data Port : RJ12 - Serial Communication Tuner : ATSC, NTSC, QAM Screen Modes (16:9) : Letterbox Screen Modes (4:3) : Yes



EBS-SP15 Calibration Cloning Tool is specifically designed to assist in the installation of large numbers of Sony monitors with our hospitality TV tuners. Quickly learn up to four different tuner settings and then transfer these settings to a other monitors with either EBS-SP10 or ICS-SP20 installed. Transfer time is within seconds, making the configuration of each monitor quick and simple.



Specifications & information are subject to change without notice.

Price and product updates found at www.SonyPro.us

★ = Key feature that differentiates from competitors

SONY® Installation Projectors



VPL-FX52 & VPL-FX52L

6000 ANSI XGA LCD Projector with Network Control



High output performance combined with acceptance of a wide range of signals including digital signals means the VPL-FX52 can be used everywhere from large venue to meeting room applications. The VPL-FX52 can be mounted on a ceiling, on a floor, or installed in a rear projection system.

VPL-FX52L is without a lens.

APPLICATION NOTE: Interchangeable lenses make the FX52 ideal for sanctuary and auditorium use where a far throw is required from the back of the hall or where a short throw is needed for rear screen projection. The 6000 lumen output is ample to handle most ambient light conditions, but for additional output dual FX52s could be stacked and aligned. Since the FX52 is often used with large screens, you may want to be certain to scale standard video and other sources up to the native resolution of the projector, so scan lines are not so apparent from in the blown-up image. A Kramer VP 727 switcher-scaler or Sony Anycast can achieve this scaling while saving you with one cable run to the projector.

Distance Calculations:

Dia (in)	Screen Width (in)	Screen Height (in)	Min Throw Distance (FT)	Max Throw Distance (FT)
4:3 Screens				
84	67	50	10.5	12.9
92	74	55	11.6	14.2
100	80	60	12.6	15.4
120	96	72	15.2	18.6
150	120	90	19.1	23.3
180	144	108	22.9	28.1

VPLL-FM21

Optional Fixed Focal Length Short Throw Lens
Throw Distance: Screen Width x 0.9 range

VPLL-ZM31

Option Short Throw Zoom Lens
Throw Distance: Width x 1.55 to Width x 1.65 range

VPLL-ZM101

Optional Long Throw Zoom Lens
Calc: Width x 3.4 to Width x 4.9 range

NAVITAR 356MCZ087

Optional Long Throw Zoom Lens
Calc: Width x 5.0 to Width x 8.3 range

NAVITAR 356MCZ900

Optional Long Throw Zoom Lens
Calc: Width x 5.8 to Width x 8.6 range

PJNET

Projector network control software

PR620

Ceiling Mount For the VPL-FX52





Specifications & information are subject to change without notice.

★ = Key feature that differentiates from competitors

Price and product updates found at
www.SonyPro.us

SONY VPL-FX52 Specifications

Picture

Model/Description



Specifications:

- XGA (1024 x 768) 3 1.3" LCD Panels
- 10 Base-T/100 Base-TX Ethernet for LAN connection (Control & Presentation)
- Supports VGA thru UXGA
- 6000 ANSI lumens
- Remote Monitoring via Internet Browsers
- Emergency Email Notification
- Powered Lens Shift (For stacking for fine vertical image adjustments)
- Format: 4:3 Native
- Up to 300" dia screens
- 1.3 times Power zoom, F1.7 to 2.0
- ±20° Digital Keystone
- Contrast ratio: 700:1,
- Lamp: 300W UHP, 1500 hours
- Inputs:
 - DVI-I x 1, S-Video x 1
 - Composite Video x 1, Component BNCx5
 - RS232 x 1, Ethernet x 1, Control-S x 1,
 - 12V Screen Trigger x 1, PC Card Slot
- Acceptable Video Signals:
 - NTSC3.58, PAL, SECAM, NTSC4.43, PAL-M,
 - PAL-N (automatically/manually selected)
 - RGB (fH 15 - 92 kHz, fv 48 - 92 Hz) up to UXGA 60Hz
- 19" x 6 5/8" x 19 7/8" Net Weight: 23 lbs
- Shipping Weight: 36 lbs

Special Features:

- **Direct Power On/Off** - Unlike most other projectors the VPL-FX52 can be powered off by cutting the AC supply. Internal circuits provide lamp cool-down. Unit can also be powered up in same fashion with projector power control via the light switch.
- **Network Presentations** - Internal web-server allows for presentation, image, and document upload. Display these items via browser control or IR remote
- **PJNet Connectivity** - With PJNet the VPL-FX52 can report back lamp hours used, operating status, and it can be programmed to alert AV managers via an email message when it is time for maintenance.
- **Back to Front Tilt** - Can be tilted 90 degrees upward/downward. Ideal for digital signage applications.

Supplied Accessories: Remote Commander, AA Batteries (2), Lens Cap, Operation Manual, Installation Manual for Dealers

Specifications & information are subject to change without notice.

Price and product updates found at
www.SonyPro.us

SONY® Installation Projectors



Power Zoom/Focus
 Picture Shift
 Digital Keystone Adjustment
 Direct Power On
 12-Bit 3D Gamma Correction
 Centered Lens Design
 Twin Stacking Capability

Distance Calculations:

Dia (in)	Screen Width (in)	Screen Height (in)	Min Throw Distance (FT)	Max Throw Distance (FT)
4:3 Screens				
60	48	36	7.4	8.7
80	64	48	9.9	12.7
100	80	60	12.5	15.8
120	96	72	15	19.1
150	120	90	18.8	23.9
180	144	108	22.6	28.8
300	240	180	37.8	48
600	480	360	76	96.3

VPL-FX40, VPL-FE40, VPL-FX40L, VPL-FE40L
 LCD 4000 Projectors Network Control & presentation from any PC on the network.

Features:

- FX-40 XGA (1024 x 768)
- FE-40 SXGA+ (1400 x 1050)
- 10 Base-T/100 Base-TX ethernet for LAN connection
- Supports VGA thru SXGA
- 4000 ANSI lumens; 3200 (economy mode)
- Format: 4:3 Native
- Up to 600" diagonal screens
- 1.3 times manual zoom, F1.66 to 2.18
- ±20° Digital Keystone
- Contrast ratio: 2000:1,
 Lamp: 275W UHP, 2000/3000 hours
- Inputs:
 VGA 15 Pin x 2, HDMI x 1, S-Video x 1 Composite Video x 1, Component BNCx5, RS232 x 1, Audio 3.5mm x 2, RJ45 Ethernet x 1, Control-S x 1
- Output:
 VGA 15 Pin x 1
- Acceptable Video Signals: NTSC, PAL, SECAM, HDTV up to 1080i, 720p
- 21" x 5.75 x 13.8"
- Shipping Weight: 21 lbs



Supplied Accessories:
 Remote commander, Computer Video Cable (2 m), AA size Battery (x 2), Lens Cap, Air Filter, Operating Manual, Installation Manual

VPL-FX40L & VPL-FE40L are without a lenses

LMP-F270

UHP type lamp

PM-1 Universal Omnimount

Universal Ceiling Mount with 12-18" Adjustable Pipe

VPLL-1008

Fixed Lens F2 Short Throw .78:1

VPLL-Z1024

Long Throw Replacement Lens
 F2.0 - 2.3 Throw ratio 2.38-3.26:1 Zoom 1.45

VPLL-Z1032

Long Throw Replacement Lens
 F2.0 - 2.4 Throw ratio 3.24-4.95:1 Zoom 1.6



Specifications & information are subject to change without notice.

Price and product updates found at www.SonyPro.us

★ = Key feature that differentiates from competitors

SONY Small Format Projectors



VPL-CX86

3000 ANSI XGA Projector with Wireless Presentation



The VPL-CX86 Wireless Projector is ideal for handling presentations when you are always on the move. The VPL-CX86 is so flexible and versatile it meets the demands of the road, in the boardroom and everywhere in between.

Sony Lamp-Life Saver Feature:
The VPL-CX86 features stored-energy fan for cooling. Power can be turned off at the wall switch and the units will cool themselves.

Features:

- XGA (1024 x 768) 3 0.79" LCD Panels
- Supports VGA thru SXGA
- 3000 ANSI lumens
- Format: 4:3 Native
- Up to 300" dia screens
- 1.2 times Power Zoom/Focus, F1.6 to F1.78
- Auto Focus ★
- ±15° Digital vertical Keystone
- Horizontal SideShot® Keystone adjustment ★
- Contrast ratio: 350:1
- Lamp: 190W UHP, 2000/3000 hours
- Inputs:

VGA 15 Pin x 1, S-Video x 1
Composite Video x 1,
RS232 x 1, USB x 1
Audio 3.5mm x 1, USB x 2

- Acceptable Video Signals:
NTSC, PAL, SECAM,
HDTV up to 1080i, 720p
- 13 x 3.8 x 11.3" Net Weight: 8.4 lbs
- Shipping Weight: 16 lbs

Supplied Accessories: Wireless LAN Card, Computer Video cable USB cable, USB Wireless LAN Module, AA batteries, Remote Commander, Quick reference sheet, Operating Instructions, Carrying case, Air filter (for replacement), AC Power Cord, Presenter Tool: RMPJP1

Distance Calculations:

Dia (in)	Screen Width (in)	Screen Height (in)	Min Throw Distance (FT)	Max Throw Distance (FT)
4:3 Screens				
84	67	50	8.2	9.7
92	74	55	9	10.7
100	80	60	9.8	11.6
120	96	72	11.8	13.9
150	120	90	14.7	17.4
180	144	108	17.7	21

LMP-C190

190W UHP Lamp for the VPL-CX80, VPL-CX85/86

PM-1 Universal Omnimount

Universal Ceiling Mount with 12-18" Adjustable Pipe

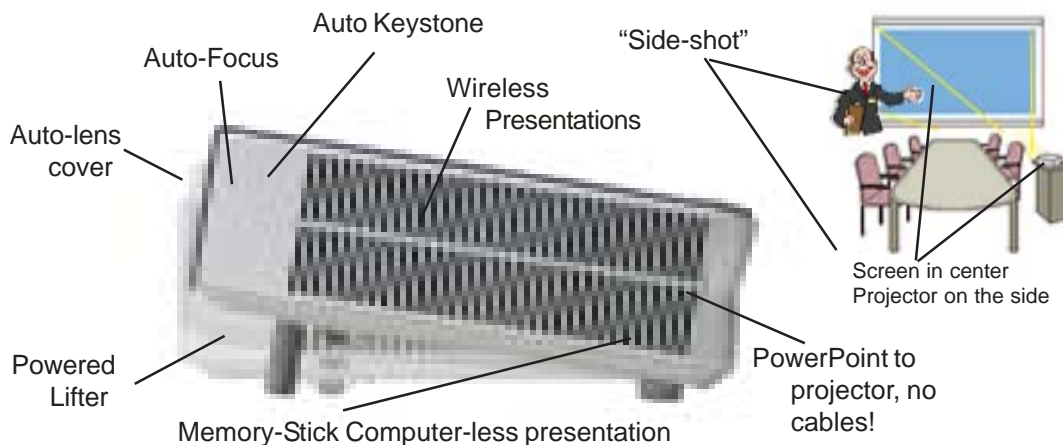



Specifications & information are subject to change without notice.

Price and product updates found at
www.SonyPro.us

SONY® Small Format Projectors



The VPL-CX63 projector is ideal for high-impact presentations on the go or installed in the conference room.

Sony Lamp-Life Saver Feature:
 The VPL-CX63 features stored-energy fan for cooling. Power can be turned off at the wall switch and the units will cool themselves.

Distance Calculations:

Dia (in)	Screen Width (in)	Screen Height (in)	Min Throw Distance (FT)	Max Throw Distance (FT)
4:3 Screens				
84	67	50	8.2	9.7
92	74	55	9	10.7
100	80	60	9.8	11.6
120	96	72	11.8	13.9
150	120	90	14.7	17.4
180	144	108	17.7	21

VPL-CX63 3000 ANSI XGA Projector

Features:

- XGA (1024 x 768) 3 0.79" LCD Panels
- Supports VGA thru SXGA
- 3000 ANSI lumens (2400 in lamp saver mode)
- Format: 4:3 Native
- Up to 300" dia screens
- 1.2 times Power Zoom/Focus, F1.6 to F1.78
- Off & Go - fan cools after power disconnect
- Digital Zoom • Freeze function
- Keystone adjustment +/-20%
- Contrast ratio: 350:1
- Lamp: 190W UHP, 2000/3000 hours
- Inputs:
 - VGA 15 Pin x 2
 - Composite Video x 1, S-Video x 1
 - RS232 x 1, USB x 1
 - Audio 3.5mm x 1, USB x 2
- Acceptable Video Signals:
 - NTSC, PAL, SECAM,
 - HDTV up to 1080i, 720p
- 13 x 3.25 x 11.25" Net Weight: 8.3 lbs
- Shipping Weight: 16 lbs



Supplied Accessories: Computer Video cable, USB cable, AA batteries, Remote Commander, Quick reference sheet, Operating Instructions, Carrying case, Air filter (for replacement), AC Power Cord, Presenter Tool: RMPJP1

LMP-C190

190W UHP Lamp for the VPL-CX63 & VPL-CX61

PM-1 Universal Omnimount

Universal Ceiling Mount with 12-18" Adjustable Pipe



Specifications & information are subject to change without notice.

Price and product updates found at www.SonyPro.us

★ = Key feature that differentiates from competitors

SONY Small Format Projectors



VPL-CX76

2500 ANSI XGA Projector with Wireless Presentation



The VPL-CX76 Wireless Projector is ideal for handling presentations when you are always on the move.

The VPL-CX76 is so flexible and versatile it meets the demands of the road, in the boardroom and everywhere in between.

Sony Lamp-Life Saver Feature:
The VPL-CX76 features stored-energy fan for cooling. Power can be turned off at the wall switch and the units will cool themselves.

Features:

- XGA (1024 x 768) 3 0.79" LCD Panels
- Supports VGA thru SXGA
- 2500 ANSI lumens
- Format: 4:3 Native
- Up to 300" dia screens
- 1.2 times Power Zoom/Focus, F1.6 to F1.78
- Auto Focus ★
- ±15° Digital vertical Keystone
- Horizontal SideShot® Keystone adjustment ★
- Contrast ratio: 350:1
- Lamp: 165W UHP, 2000/3000 hours
- Inputs:

VGA 15 Pin x 1, S-Video x 1
Composite Video x 1,
RS232 x 1, USB x 1
Audio 3.5mm x 1, USB x 2
Memory-stick

- Acceptable Video Signals:
NTSC, PAL, SECAM,
HDTV up to 1080i, 720p
- 11.7" x 2.7" x 9.6" Net Weight: 6.4 lbs
- Shipping Weight: 12 lbs

Supplied Accessories: Wireless LAN Card, Computer Video cable USB cable, USB Wireless LAN Module, AA batteries, Remote Commander, Quick reference sheet, Operating Instructions, Carrying case, Air filter (for replacement), AC Power Cord, Presenter Tool: RMPJP1

Distance Calculations:

Dia (in)	Screen Width (in)	Screen Height (in)	Min Throw Distance (FT)	Max Throw Distance (FT)
4:3 Screens				
84	67	50	8.2	9.7
92	74	55	9	10.7
100	80	60	9.8	11.6
120	96	72	11.8	13.9
150	120	90	14.7	17.4
180	144	108	17.7	21

LMP-C161

165W UHP Lamp for the VPL-CX70 & VPL-CX76

PM-1 Universal Omnimount

Universal Ceiling Mount with 12-18" Adjustable Pipe

★ Simplify your life:

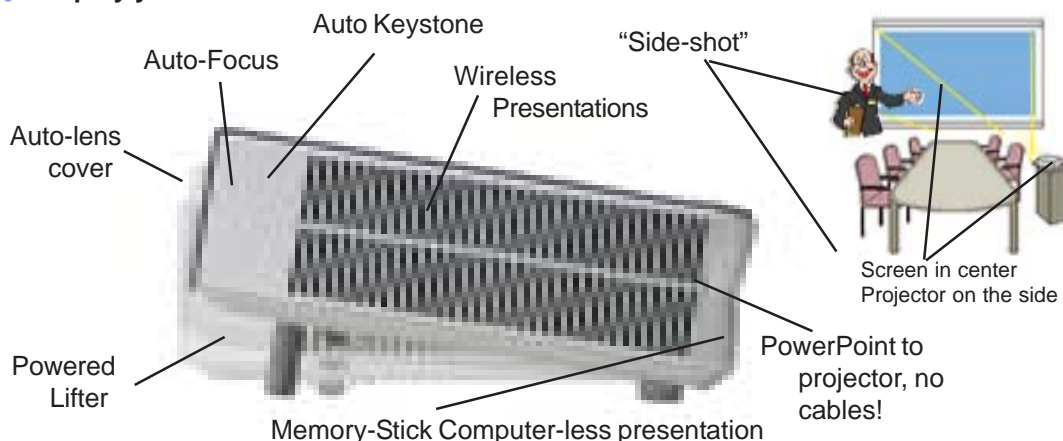



Specifications & information are subject to change without notice.

Price and product updates found at

www.SonyPro.us

SONY® Small Format Projectors



The VPL-CX61 projector is ideal for high-impact presentations on the go or installed in the conference room.

Sony Lamp-Life Saver Feature:
The VPL-CX61 features stored-energy fan for cooling. Power can be turned off at the wall switch and the units will cool themselves.

Distance Calculations:

Dia (in)	Screen Width (in)	Screen Height (in)	Min Throw Distance (FT)	Max Throw Distance (FT)
4:3 Screens				
84	67	50	8.2	9.7
92	74	55	9	10.7
100	80	60	9.8	11.6
120	96	72	11.8	13.9
150	120	90	14.7	17.4
180	144	108	17.7	21

VPL-CX61 2500 ANSI XGA Projector

Features:

- XGA (1024 x 768) 3 0.79" LCD Panels
- Supports VGA thru SXGA
- 2500 ANSI lumens
- Format: 4:3 Native
- Up to 300" dia screens
- 1.2 times Power Zoom/Focus, F1.6 to F1.78
- Off & Go - fan cools after power disconnect
- Digital Zoom
- Freeze function
- Keystone adjustment +/-20%
- Contrast ratio: 350:1
- Lamp: 190W UHP, 2000/3000 hours
- Inputs:
 - VGA 15 Pin x 2
 - Composite Video x 1, S-Video x 1
 - RS232 x 1, USB x 1
 - Audio 3.5mm x 1, USB x 2
- Acceptable Video Signals:
 - NTSC, PAL, SECAM,
 - HDTV up to 1080i, 720p
- 13 x 3.25 x 11.25" Net Weight: 8.3 lbs
- Shipping Weight: 16 lbs



Supplied Accessories: Computer Video cable, USB cable, AA batteries, Remote Commander, Quick reference sheet, Operating Instructions, Carrying case, Air filter (for replacement), AC Power Cord, Presenter Tool: RMPJP1

LMP-C190

190W UHP Lamp for the VPL-CX61 & VPL-CX63

PM-1 Universal Omnimount

Universal Ceiling Mount with 12-18" Adjustable Pipe



Specifications & information are subject to change without notice.

Price and product updates found at www.SonyPro.us

SONY Portable & Economy Projectors



Ultra-Portable Business Projectors

Ideal for Field Sales Staff and Others Always on the Move.

The VPL-CS21 and VPL-CX20 feature high portability, Automatic Setup, high brightness and Anti-theft functions.

VPL-CS20

2100 ANSI SVGA Projector
(800X600) 3- .63" LCD Panels

VPL-CX20

2100 ANSI XGA Projector
XGA (1024X768) 3- .63" LCD Panels

Features Common to both projectors:

- Supports VGA thru XGA
- 2100 ANSI lumens (1600 in lamp saver mode)
- Format: 4:3 Native
- 40" up to 300" dia screens
- Off & Go - fan cools after power disconnect
- 4 Digital Zoom
- Image flip
- Power focus / power zoom (1.2X)
- Anti-theft features
- Picture Muting
- Keystone adjustment +/-20%
- 6 picture modes

- Freeze function
- Contrast ratio: 350:1,
Lamp: 165W UHP, 2000/3000 hours
- Inputs:
VGA 15 Pin x 1
Composite Video x 1, S-Video x 1
Audio 3.5mm x 1
- Acceptable Video Signals:
15KHz RGB, NTSC, PAL, SECAM,
HDTV up to 1080i, 720p
- 10 3/4 x 2 1/8 x 8 3/8"
- Shipping Weight: 4.2 lbs



Compact Economy Projectors

Ideal for Education and other price sensitive customers.

VPL-ES4

2200 ANSI SVGA Projector
(800X600) 3- .63" LCD Panels

VPL-EX4

2100 ANSI SVGA Projector
(1024x768) 3- .63" LCD Panels

Features Common to both projectors:

- Dynamic detail enhancer for crisper images
- 7 picture modes for varying room environments and desired content image
- Quickstart - 4 secs.
- Format: 4:3 Native
- 40" up to 300" dia screens
- Security bar to attach a security cable to
- Power saving mode turns off when not in use
- Up to SXGA display
- 1.2 zoom lens
- 30 degrees of keystone adjustment

- Contrast ratio: 350:1,
Lamp: 165W UHP, 2000/3000 hours
- Inputs / Outputs:
VGA 15 Pin x 2; Composite Video x 1, S-Video x 1;
Audio 3.5mm x 1; VGA Monitor out
- Acceptable Video Signals: 15KHz RGB, NTSC, PAL, SECAM, HDTV up to 1080i, 720p
- 12 1/8 x 3 7/8 x 9 7/8"
- Shipping Weight: 6.5 lbs



Specifications & information are subject to change without notice.

Price and product updates found at
www.SonyPro.us

SONY® High Definition Widescreen Projectors

VPL-VW100

LCOS High Def Projector



Limited Warranty :
2 Years Parts and Labor
Lamp Warranty - 90 Days

Features:

- Full HD 1920 x 1080 SXRD™ Panel (0.61")
- Up to 15,000:1 Contrast Ratio (with Advanced Iris function on)
- ARC-F (All Range Crisp Focus) Lens
- 1080p 24p Input over HDMI™ for Cinematic Motion
- Pure Xenon Lamp (400W)
- Advanced Iris Function (Auto, On, Off)
- Low Fan Noise (22dB)
- 1.8X Zoom
- DRC®-MFv2 (-Digital Reality Creation®-Multi-Function V2)
- Noise Reduction
- Lens Shift
- RCP (Real Color Processing) Function (User 1, 2, 3 and Off)
- HD I/P Converter
- 12-bit Panel Drive Full Digital Chassis
- 3D Comb Filter
- HDMI™ Connector
- Picture Mode (Dynamic, Standard, Cinema, Custom)
- Black Level Adjustment (High, Low, Off)
- Gamma Correction (Gamma 1, 2, 3 and Off)
- Color Temperature (High, Medium, Low and Custom 1, 2, 3)
- Color Space (Normal and Wide)
- Dimensions- Width : 19.53" Height : 6.89" Depth : 22.60"
- Weight: 41lbs 13oz (19kg)

VPL-VW50

LCOS High Def Projector



Limited Warranty:
2 Years Parts and Labor
Lamp Warranty - 90 Days

- Display Resolution : 1920 x 1080
- Contrast Ratio : Up to 15000:1 (with Advanced Iris Auto ON)
- 900 lumens
- Ultra High Pressure Lamp (200W) for natural color
- Quiet operation with low fan noise of 22 dB
- Component/Progressive : DTV (480/60i, 575/50i, 480/60p, 575/50p, 720/60p, 720/50p, 1080/60i, 1080/50i), 1080/60p (DVI and HDMI channel only), Composite video, Y/X video
- CONNECTIONS: Component Video (Y/Pb/Pr) Input: 1, Composite Video Input:1, S-Video Input: 1, HDMI™ Connections: 2 PC Input: 1 Network Connection: 1, RS-232C: D-sub 9-pin (female), RJ-45 10 BASE-T/100BASE-TX, Remote Connector 12V Trigger Input : 1 Mini Jack - Power On: DC 12V
- Lens: fl 8.7 to 33.7 mm/F2.54 to 3.53 mm
- Dimensions- Width : 15.55", Height : 6.83", Depth : 18.56"
- Weight: 24.25 lbs

Spare Lamps

LAMP	PROJECTOR	LAMP	PROJECTOR
LMP600	600 Series LCD projectors.	LMPF270	VPL-FE40/FE40L and VPL-FX40/FX40L
LMPC120	VPL-CS1	LMPF300	VPL-FX51
LMPC121	VPL-CS3	LMPH130	VPLHS51
LMPC132	VPL-CX10	LMPH400	VPLVW100
LMPC133	VPLCS10	LMPL2000	VPD-LE100
LMPC150	VPL-CS5 & VPL-CX5	LMPM130	VPDMX10
LMPC160	VPL-CX11	LMPP120	VPL-PX1
LMPC161	VPL-CX70,VPL-CX75,VPL-CX76	LMPP200	VPL-VW10HT, VPL-PX20 & VPL-PX30
LMPC162	VPL-CS20A and VPL-CX20A	LMPP201	VPL-PX21, VPL-PX31, VPL-VW11HT, VPL-VW12HT
LMPC162	VPL-CS21 and VPL-CX21	LMPP202	VPL-PS10, VPL-PX10, and VPL-PX15
LMPC190	VPL-CX85	LMPP260	VPL-PX40
LMPE150	VPL-ES2	LMPQ120	VPL-FE100U
LMPE180	VPL-ES1	LMPS120	VPL-FE100
LMPF250	VPL-FX50	LMPC163	VPL-CS21/CX21

Small format amplifiers for projector reinforcement & plenum boxes



from the wizardry of Nigel B



NB-70AMP 70v / 25v 45-watt Dual Zone Amplifier*
NB-2075 45 watt, 8-ohm Stereo Amplifier*



NB-2052PL Mono/Stereo Auto Amplifier 45 watts RMS with RS 232 Control*
NB-7052PL 70/25 Volt 45 watt RMS Automatic Mono/Stereo Amplifier, with RS 232 Control & Selectable Inputs*

*Requires NB-PS-75 External Power Supply



NB-PEBPM 14" x 14"
Plenum Equipment Box with Pole Mount



NB-PLWB 14" x 14"
Plenum Equipment Box with Flat Surface Mounting



NB-PLHK Hanging Kit
with all Hardware for Flat Surface Mounting

Elite SCREENS



PRO-HOME Electric Series

Premium motorized screen. The tubular motor results in faster lowering & raising. An extruded aluminum casing (anti-rust), providing a stylish appearance (white finish). The extrusion allows slotted hanging brackets to be adjusted to anchor positions. Aspect models of 1:1, 4:3 and 16:9 available from 82" to 160", where 120" and 150" models have Matte with Fiber Glass screen material, to provide flatter screen surface. Includes IR remote control, wired 3-way wall switch (removable) and wall/ceiling mount bracket included. **An optional 12 volt trigger adapter to allows control system interface.** Built-in Vertical Drop/Rise Adjustment - Conveniently program up/down position 100+ degree screen angle.

NEW

ELECTRIC SPECTRUM Series. 84", 100" & 125" in 4:3 and 16:9 with built-in low voltage trigger.



VMAX Electric Series

Motorized screen includes IR and RF remote controls. Extra Top 18" Black Drop - Perfect for High Ceiling Installations. Synchronized motor, Programmable vertical limit switch. Metal case with hanging points on the ends available in white or black finish. 6" L brackets included. 3-Way inline-switch. Aspect models of 1:1, 4:3 and 16:9 available from 82" to 150" diagonal.

NEW

SILVER MAX. High-gain surface reflects brighter image for cinema viewing in 82", 106", & 120" sizes.

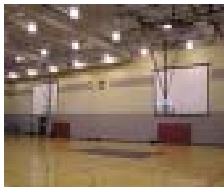

VMAX PLUS. Large Venue 180-235" sizes



CINE TENSIONED tension cords run vertically down both sides of the screen to eliminate "curling", a common problem when screens are rolled up. It also increases rigidity of the projection surface, which results in an improved picture quality. Material comes in matte white, high-gain white and high contrast gray in black casings



Manual Series

Manual Pull Down Screen w/ Four Sided Black Masking Borders (Extra Top Drop) in 1:1, 4:3 & 16:9 in black or white cases.



Fixed-Frame Series 4:3 & 16:9 sizes from 84" to 200" in high contrast gray, matte or silver with adjustable tensioning.



Quickfold Series

Portable Front Projection Screen sets-up quick and breaks down into an included Aluminum Traveling Wheel Case



Tri-pod Series

Pull Up Projector Screen w/ standard Keystone Eliminator and Four Sided Black Masking Borders (Extra Top Drop).



Pull-up Series

Floor Standing, Telescoping side posts hold Pull Up Screen in 16:9, 4:3 and 1:1. Carrying Bag included.



KRAMER ELECTRONICS

Switchers



PRESENTATION SWITCHER WITH MEDIA CONTROL

VP-23RC includes 4 switchers (composite video, S-video UXGA and audio), long distance outputs and full audio features including a microphone input for reinforcement in the room and a 5 watt amplifier.



SEAMLESS SCALING SWITCHERS

VP-727 is the top of the line, providing seamless cross fades with various transition types, between sources. There's a Program and a Preview out, allowing monitoring of the next source before taking it live. The VP-727 has 8 Universal inputs on easy to terminate 5-BNC connectors, to accept composite, s-video, component, RGB, RGBs or RGBHV. Outputs include BNC and VGA 15 pin or DVI outputs for each the Program and Preview channels. A T-bar cross fade accessory will be introduced shortly.

In the contemporary House of Worship and the school or civic auditorium, large screen projection can reach 100", 300" and greater. When standard video images are magnified to this large, scaling up to the native resolution of the projector is advised to avoid magnifying the TV scan lines. Since this environment is more of a staged production environment, customers want clean transitions.

VP-724xl is a step towards the more moderate install with fade-thru-black transitioning for glitch-free switching, 2 analog 15 pin PC inputs, 1 DVI input, 1 Component video input, 2 S-Video or composite inputs, 2 15 Pin PC outputs, Picture-in-Picture insertion, IR remote and Audio-follow-video channels.

VP-720xl has the features of the 724, but less one analog PC input.

VP-719xl has the features of the 720, but less the PIP feature.

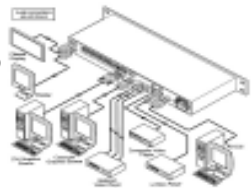
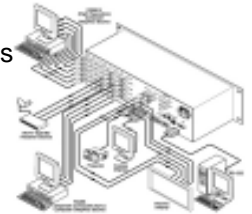
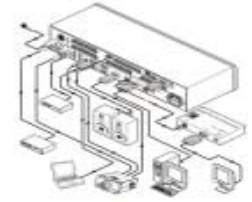

ALTINEX

Interfaces, Drivers, DAs



TABLE OR PODIUM INTERFACES

TNP-121 place the projector connection, power, network and phone in a handy position. Dual version also available.



WALL OR PANEL INTERFACES

INTERA SERIES- The ISC2001 (VGA and audio) ISV3000 (video & L-R audio) and plate IS10002 are one combination among many in this series.



DISTRIBUTION AMP

Split your PC output to 2 or more display devices with Altinex. **DA1907SX** 1x2 15pin VGA shown. BNC modles available too.

MAXIMUM RECOMMENDED CABLE LENGTHS

VGA- 15'
 S-video 50'
 Composite video- 21'
 Component video- 135'
 DVI - 15'

BEYOND THESE LENGTHS LINE DRIVERS ARE NEEDED

**For more visit the
 Altinex Reseller Portal**



NAVITAR

Long & short throw lenses



Lenses for expanding the range of your projector

5 year warranty

Replacement Lenses

NuView high resolution projection lenses internally replace the existing lens on your projector. Starin stocks for popular models for Sony, Sanyo, Hitachi, Epson, Panasonic and can quickly supply for other brands and models. .

Adapter Lenses

ScreenStar wide-angle and long throw conversion lenses externally adapt to an integral lens to increase picture size or increase your throw distance by 20-50%. There are projector mount adapters required.

OMNI MOUNT

Universal Projector and Flat Panel Display Mounts

Universal Projector Mount

The Omnimount PM series of projector mounts takes care of mounting 100's of models and brands of projectors with just a few sku's.



- _____ PMMICRO-B Projectors up to 5.5" x 7.53", 20 lbs max (Black)
- _____ PMMICRO-S Projectors up to 5.5" x 7.53", 20 lbs max (Silver)
- _____ PM1-B Projectors up to 8" x 11", 30 lbs max (Black)
- _____ PM1-S Projectors up to 8" x 11", 30 lbs max (Silver)
- _____ PM2-B Projectors up to 11" x 15", 40 lbs max (Black)
- _____ PM2-S Projectors up to 11" x 15", 40 lbs max (Silver)
- _____ PWM-A-B Projector Wall Mount Option (Black)
- _____ PWM-A-S Projector Wall Mount Option (Silver)

Universal Projector Mount

The new spider type mount adjusts to the bolt pattern of many projectors.



- _____ PRO-PJT legs adjusts to 19" for 40 lbs projectors or less, in Silver
- _____ PRO HD-PJT legs adjusts to 21" for 45 lbs projectors or less, in Black

CeilingPlate adapter

Allows hanging a projector from adropceiling tile, with cable hardware to structure anchor points.



- _____ CP 24

Fixed Universal Flat-Panel Display Mounts

Mount any flat panel monitor/tv from 17" to 63". Mounts that are VESA only require VESA compliant displays. All others will mount display if it is VESA or not.



- _____ 17FM-F 13"-24" VESA 75/100 ONLY Fixed mount 40lb. - Silver
- _____ 37FB-F-B 23"-37" VESA 75/100/200 + universal 100 lbs. - Black
- _____ 37FB-F-S 23"-37" VESA 75/100/200 + universal 100 lbs.- Silver
- _____ 54FB-F-B 32"-63" VESA 75/100/200 + universal 175 lbs.- Black
- _____ 54FB-F-S 32"-63" VESA 75/100/200 + universal 175 lbs.- Silver

OMNI MOUNT

Flat Panel Display Mounts

Tilt Universal Flat-Panel Display Mounts

Mount and tilt up to 15 degrees any flat panel monitor/tv from 17" to 63". Mounts that are VESA only require VESA compliant displays. All others will mount display if it is VESA or not.



- 17FM-T 13"-24" VESA 75/100 ONLY tilt mount 40lb. - Silver
- 37FB-T-B 23"-37" VESA 75/100/200 + universal 100 lbs. - Black
- 37FB-T-S 23"-37" VESA 75/100/200 + universal 100 lbs.- Silver
- 54FB-T-B 32"-63" VESA 75/100/200 + universal 175 lbs.- Black
- 54F3B-T (color) Universal Tilt Mount 32"-63" VESA 75/100/200 + universal 175 lbs.- Silver

Retractable Universal Flat-Panel Display Mounts

Mount and retract any flat panel monitor/tv from 17" to 50". These mounts are VESA only, but for displays 23" and up add the 48UAA-A-B to mount non-VESA displays.



- 17ARM 13"-24" VESA 75/100 ONLY Retractable 30lb. - Silver
- 37ARM-B 23"-37" VESA 75/100/200 ONLY 80 lbs. - Black
- 37ARM-S 23"-37" VESA 75/100/200 ONLY 80 lbs.- Silver
- 48ARM-UA-B 32"-50" VESA 75/100/200 ONLY 150 lbs.- Black
- 48ARM-UA-S 32"-50" VESA 75/100/200 ONLY 150 lbs.- Silver
- 48UAA-A-B Universal adaptor plate - Black
- 48UAA-A-S Universal adaptor plate - Silver
- 54HDARM VESA 100/200 ONLY 120 lbs. Silver or Black
- 63HDARMUA ARTICULATED RETRACTABLE MOUNT WITH UNIVERSAL ADAPTER
VESA compliant: up to 400x800 ONLY 200 lbs.

Shadow box recesses the mount into the wall to provide a flush mount appearance.

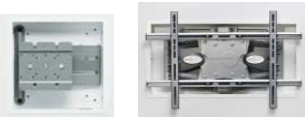

- SB1 Shadow Box 1- for 37ARM and 37HDARM articulated arm mounts
- SB2 Shadow Box 2- for 48ARM, 54HDARMUA, 63HDARMUA and flat and tilt mounts

Ceiling mounting



- Tilt PA mounting adapter for 1.5" threaded pipe 15 to 45 degree tilt in black
- TPUM1 mounting plate adapter with tilt PA VESA compliant: up to 400x800 ONLY 175 lbs.
- SCM Single Ceiling Mount 37" to 60" Tilt & Lock VESA 100/200 ONLY 200 lbs.
- SCM UA 63UCA mounting plate adapter with SCM VESA: up to 400x800 ONLY 200 lbs.
- DCM Double ceiling mount 5-30 degree tilt VESA 100/200 ONLY 400 lbs.
- DCM UA Dual 63UCA mounting adapter with SCM VESA: up to 400x800 ONLY 400 lbs

Floor Stand Flat Base



- FSUA Includes 63UCA-A fitting most large to xlarge flat panels, ONLY 200 lbs., adjustable shelf
- FSS - Floor stand shelf adds on to FSUA vented & light weight



Professional AV Representatives

Loft AV
P: 847-564-9614

Starin Marketing, Inc.
P: 219-929-4127
F: 219-929-4377



Cowser-Lee Marketing
P: 817-572-6433
F: 817-478-5262

BC Electronics Sales Inc
P: 913-962-1990
F: 913-962-0718

Sony Video
Nu-Way Technologies
P: 334-222-8950
F: 334-222-4317

ALL SALES

All accounts are COD Certified/CIA/MasterCard/visa until credit is approved. If credit is approved, terms will be COD (Company Check) or NET 30 as determined by credit department.

PAYMENT TERMS

30-day terms are allowed on credit approved accounts. Payments paid within the terms are defined as those payments received and posted to your account no later than 30 days from the invoice date.

SHIPPING

FOB Starin Distributing 136 Venturi Drive Chesterton, IN 46304.

MINIMUM ORDER

There is no minimum order.

PAST DUE ACCOUNTS

All invoices are due according to the terms stated on the invoice. A finance charge of 1.5% per month will be assessed on the unpaid balance of all invoices past due. In the event a finance charge is not assessed on a monthly basis that shall not be deemed a waiver of our right to assess such charges at a later date. Accounts extending 45 days beyond the invoice date may be placed on COD Certified, CIA or Credit Card status. Accounts extending 65 days may be referred to an agency for collection.

RETURNED CHECKS

A \$30 charge is applied to all checks returned for insufficient funds and discount privileges are forfeited on applicable invoices.

DEFAULT

In the event collection is required for past due invoices and accounts, you agree to pay reasonable costs and attorney fees incurred.

SHORTAGES OR DAMAGED SHIPMENTS

All shortages or damaged shipments must be noted on carrier's bill of lading or similar document. A claim against the carrier must be filed per ICC regulations and we must be notified in writing within 10 days of the invoice date.

RETURN POLICY

A return authorization (RA) number must accompany all merchandise returned for credit. A 25% restocking charge may be assessed on all returned goods. Special Orders may not be returned.

REPAIR/RETURN POLICY

Repairs of defective merchandise under warranty should be arranged between the end user and the manufacturer. Merchandise should not be returned to Starin Distributing for repair unless instructed to do so. A return authorization (RA) number must accompany all merchandise returned for repair along with information that will assist in the diagnosing of the problem.

PRICING POLICY

Prices are subject to change without notice.

DEALER AGREEMENTS

Select brands require a signed dealer agreement before any product can be shipped

MAP POLICY

Minimum Advertised Price ("MAP") unilaterally sets the MAP on all products (where it is listed) by all means of solicitation, including electronic or print means, including facsimile, Internet Web Site, On-Line Service, Newspaper, Magazine, Newsletter, Direct Mailing, or similar means. Dealers who advertise products below MAP pricing will be terminated immediately.