

# SONY

## BLACK & WHITE MONITOR

# SSM-125

### BLACK & WHITE MONITOR

- 12-inch CRT size
- Excellent picture quality with more than 750 TV line horizontal resolution
- Dual loop-through video inputs, with switchable 75Ω termination
- DC clamp switch provides a stable reference for the black level
- Front controls: Power, INPUT select, H-hold, V-hold, contrast and brightness
- Faster horizontal AFC reduces flagging on time lapse VCR playback



# SSM-125

## BLACK & WHITE MONITOR

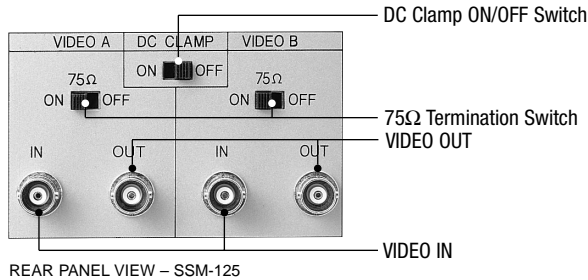

### System Connections

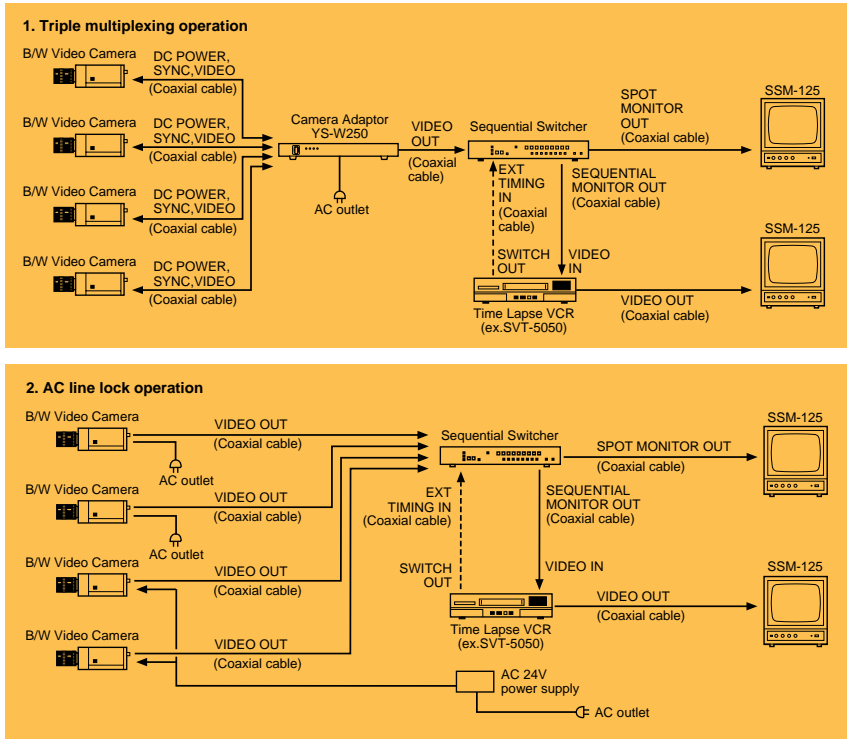

## SPECIFICATIONS

### SSM-125

**Video signal system:** EIA standard

**Picture tube:** 12-inch B/W measured diagonally, 90° deflection

**Video input:** Impedance 75Ω high switchable  
Level 0.5 – 2.0Vp-p/75Ω, sync negative, BNC-type (x 2)

**Video output:** Impedance more than 10kΩ, loop-through,  
BNC-type (x 2)

**Horizontal resolution:** More than 750 TV lines (at center)

**Power requirements:** AC 120V, 50/60Hz

**Power consumption:** 30W

**Operating temperature:** 0 to 35°C (32 to 95°F)

**Storage temperature:** -10 to 40°C (14 to 104°F)

**Mass:** 9.2kg (20 lb 5 oz)

**Dimensions:**

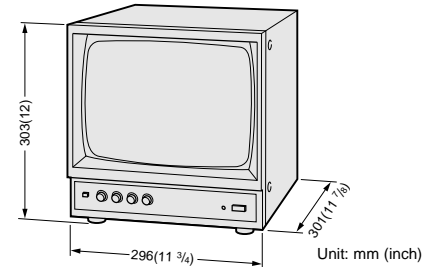

### Optional Accessory:

**SMB-121:** 19" rack kit (7 rack units high)

© 1998 Sony Electronics Inc. All rights reserved.  
Reproduction in whole or in part without written permission is prohibited. All specifications are subject to change without notice.  
Sony and Nothing Escapes Us are trademarks of Sony.

# SONY

Sony Security Systems  
Business and Professional Group  
1 Sony Drive  
Park Ridge, New Jersey 07656-8003  
TEL: (201) 358-4954 • FAX: (201) 358-4927

Printed in U.S.A. 03/98 S-SSM125

