

SONY[®]

EIA

Black and White Video Cameras
SSC-M183/M383



Lens is optional.

Black and White Video Cameras

SSC-M183/M383



Sony's new versatile and stylish SSC-M183 and SSC-M383 black and white cameras are specifically designed for surveillance and monitoring applications ranging from building and airport security to banking and retail stores, and more!

Incorporating the latest Sony CCD technology, these cameras produce images with high picture quality and remarkable sensitivity with a S/N ratio of more than 50 dB. In addition, these cameras offer dual power capability (AC 24 V and DC 12 V) to safeguard against unwanted power supply compatibility issues.

The SSC-M183 and SSC-M383 cameras are encased in an aesthetically pleasing and compact design perfectly suited for commercial and fashionable facilities such as retail stores, shopping malls, stadiums, arenas, banks and office buildings. What's more, these cameras are equipped with outstanding features including Back-Light Compensation to counteract shadow casting, CCD IRIS™, Turbo AGC (up to 24 dB) enabling subjects within low illuminated areas to be more clearly distinguished, and an extensive choice of lens options and connection capability.

Sony's SSC-M183 and SSC-M383 cameras are the ideal choice for a wide range of surveillance applications - offering excellent performance, dependability and sophisticated design, all at an affordable price.

High picture quality

The SSC-M383 camera incorporates a 1/3 type IT (Interline Transfer) CCD with Exwave HAD™ technology, the new Sony technology that offers extremely high picture quality and high sensitivity. The high resolution SSC-M383 camera provides 570 TV lines and a minimum illumination of 0.07 lx at F1.2 (50 IRE).

The SSC-M183 camera incorporates a 1/3 type IT Super HAD™ CCD that achieves a horizontal resolution of 380 TV lines and a minimum illumination of 0.06 lx at F1.2 (50 IRE).

Compact and stylish design

With dimensions of 60 (W) x 54 (H) x 120 (D) mm and weighing only 360 g, these compact cameras can easily be installed in places where space is limited and installation was previously difficult for larger cameras. Their stylish and unobtrusive, metallic-silver design will compliment any décor.

Tripod screw holes

Installing and setting up your camera is simple, because it already includes tripod screw holes at the top and bottom of its body. You do not need a special tripod adaptor.

BLC (Back-Light Compensation)*

Unwanted backlighting can often cause the subject matter of the image to be cast into shadows. The Back-Light Compensation (BLC) feature incorporated in these cameras will automatically compensate for such conditions and allow the subject to be easily visible with an improved level of object recognition.

* This function works when CCD IRIS is ON or when using a DC type auto iris lens.



DC servo/video servo lens connection capability

The SSC-M183 and SSC-M383 cameras can connect easily with either DC servo or video servo lenses.

AC 24 V/DC 12 V operation

These cameras accept either AC 24 V or DC 12 V power sources and will automatically switch to the appropriate mode upon receiving power.

CCD IRIS

This function allows the use of a manual iris lens instead of a more costly automatic iris lens. As the scene illumination level increases, these camera respond by automatically reducing the exposure time of the photosensors.

This is achieved by changing the electronic shutter speed of the CCD, in the range of 1/60 to 1/100,000 of a second.

CS-mount

These cameras can be used with CS-mount lenses and incorporate a back focus adjustment, allowing for easy and precise focus adjustments.

Typical System

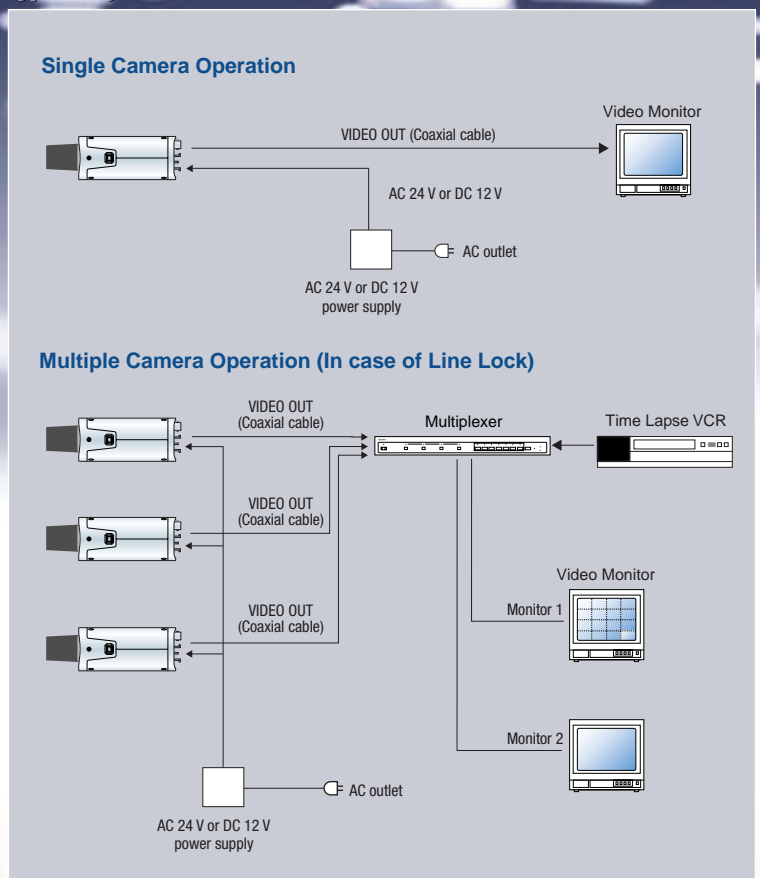

Specifications

	SSC-M183	SSC-M383
Image device	1/3 type Interline Transfer Super HAD CCD	1/3 type Interline Transfer Exwave HAD CCD
Picture elements (H x V)	510 x 492	768 x 494
Sensing area	1/3" format (4.8 x 3.6 mm)	
Signal system	EIA standard	
Sync. system	INT/LL	
Horizontal resolution	380 TV lines	570 TV lines
Lens mount	CS	
Minimum illumination	0.03 lx at F1.2 (30 IRE, AGC ON, Turbo mode) 0.06 lx at F1.2 (50 IRE, AGC ON, Turbo mode) 0.25 lx at F1.2 (100 IRE, AGC ON, Turbo mode)	0.04 lx at F1.2 (30 IRE, AGC ON, Turbo mode) 0.07 lx at F1.2 (50 IRE, AGC ON, Turbo mode) 0.3 lx at F1.2 (100 IRE, AGC ON, Turbo mode)
AGC	ON/OFF switchable	
CCD IRIS	ON/OFF (switchable), 1/60 to 1/100,000 s	
Back-Light Compensation (BLC)	ON/OFF (switchable)	
S/N ratio	More than 50 dB (AGC OFF, Weight ON)	
Video out	BNC, 1.0 Vp-p, 75 Ω, sync. negative	
Operating temperature	-10°C to 50°C (14°F to 122°F)	
Storage temperature	-40°C to 60°C (-40°F to 140°F)	
Power requirements	AC 24 V ±10%, 60Hz or DC 12 V ±10%	
Power consumption	2.5 W	2.6 W
Auto iris lens	DC/video servo (switchable)	
Weight	13 oz (360 g)	
Dimensions (W x H x D)	2 3/8 x 2 1/4 x 4 3/4 inches (60 x 54 x 120 mm)	
Supplied accessories	Lens mount cap (1) Operating instruction (1)	

Rear View

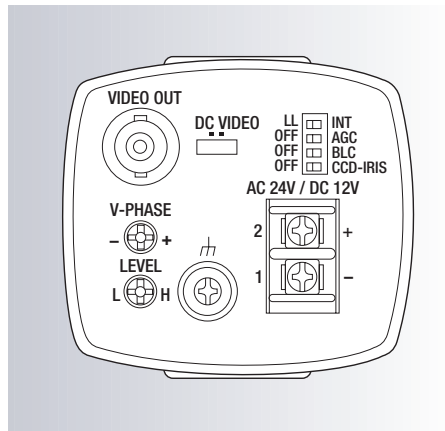

Dimensions

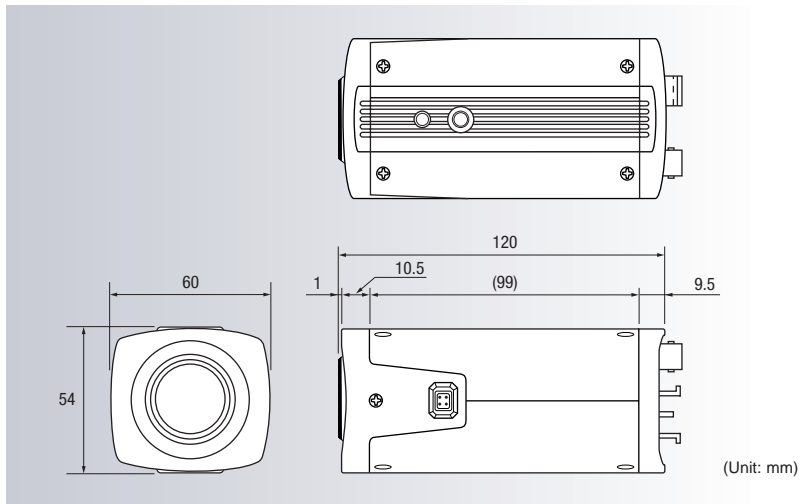

SONY

Sony Electronics Inc.
One Sony Drive
Park Ridge, NJ 07656
Tel: (201) 358-4954
Fax: (201) 358-4927
www.sony.com/security

S-SSCM183/M383
MK7739V1OHB02FEB

© 2002 Sony Electronics Inc. All rights reserved.
Reproduction in whole or in part without written permission is prohibited.
Features and specifications are subject to change without notice.
All non-metric weights and measures are approximate.
Sony, Exwave HAD, Super HAD CCD and CCD IRIS are trademarks of Sony.



Printed in U.S.A.