

# SONY®

NTSC

Color Video Camera

## SSC-DC374



Lens is optional.



## For a High Quality Video Camera at an Affordable Price, Choose Sony's New CCTV Color Camera – the SSC-DC374.

*Sony's SSC-DC374 camera offers high performance and dependability at an affordable price. Its aesthetically pleasing and compact design make this new color video camera ideal for surveillance and monitoring applications ranging from building and airport security, retail stores, shopping malls, banks, and more!*

*The SSC-DC374 camera incorporates a 1/3-type IT CCD with Super HAD™ technology, which offers a high horizontal resolution of 480 TV lines and a minimum illumination of 0.8 lx at F1.2 (50 IRE). This camera also incorporates the latest Sony DSP (Digital Signal Processing) technology providing a high level of stability and reliability. What's more, this CS-mount color video camera is equipped with other outstanding features such as Back-Light Compensation, Auto-Tracking White Balance, CCD IRIS™, and Turbo AGC™.*

*Sony's SSC-DC374 color video camera is the ideal choice for security and monitoring applications - offering high performance, reliability, and a sophisticated, compact design, all at an affordable price.*

## FEATURES

### High Picture Quality

---

The SSC-DC374 color video camera incorporates a 1/3-type IT (Interline Transfer) CCD with Super HAD technology that offers high picture quality and high sensitivity. It achieves a horizontal resolution of 480 TV lines, a minimum illumination of 0.8 lx at F1.2 (50 IRE), and a signal-to-noise ratio of 50 dB or more.

### DSP Technology

---

This new camera incorporates Sony's latest Digital Signal Processing (DSP) technology for powerful picture-contrast control. Providing outstanding stability over long periods of time, and reliability levels unattainable with analog signal processors, the SSC-DC374 color camera captures superb images under various lighting conditions.

### Compact and Stylish Design

---

With dimensions of 60 (W) x 54 (H) x 120 (D) mm and weighing only 355 g, this compact color camera can easily be installed in places where space is limited. Plus, its stylish and unobtrusive metallic-silver design complements any décor.

### CCD IRIS™

---

This function allows the use of a manual iris lens instead of a more costly automatic iris lens. As the scene illumination level increases, this camera responds by automatically reducing the exposure time of the photo sensors. This is achieved by changing the electronic shutter speed of the CCD, within the range of 1/60 to 1/100,000 (NTSC) of a second.

## Back-Light Compensation (BLC)

Unwanted backlighting can often cause the subject matter of the image to be cast into shadows. The Back-Light Compensation (BLC) function incorporated in this camera automatically compensates for such conditions and allows the subject to be more visible.

## Auto-Tracking White Balance (ATW) and Turbo AGC

The SSC-DC374 color video camera accommodates other convenient functions for enhanced operations in various lighting conditions. The Auto-Tracking White Balance function automatically adjusts the camera white balance in accordance with any changes in the lighting environment. While the Turbo AGC allows the user to boost the camera gain (up to 24 dB), enabling subjects to be more clearly distinguished in low-light conditions.

## SYSTEM CONFIGURATIONS

### Single Camera Operation

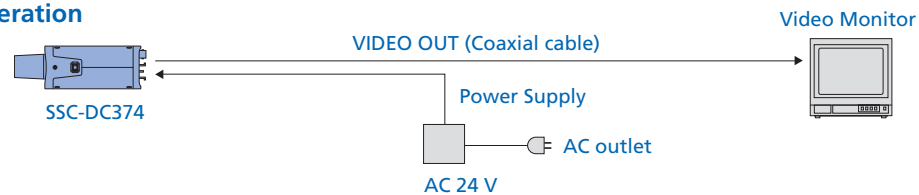

### Multi Camera Operation with Line Lock Operation

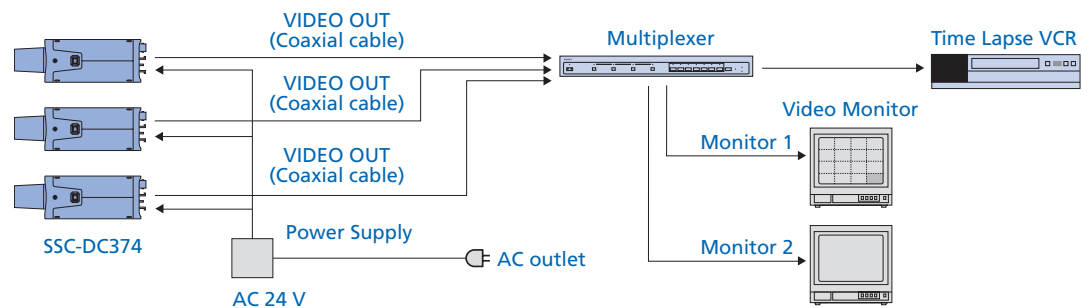

### Multi Camera Operation over LAN

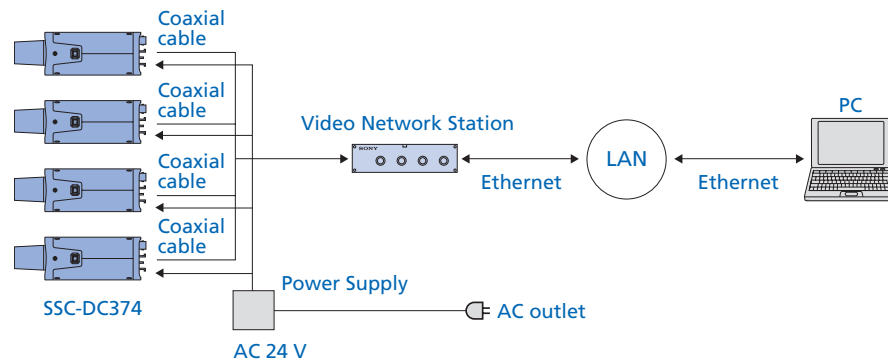

# SPECIFICATIONS

SSC-D374	
Image device	1/3 type Super HAD CCD
Picture elements (H x V)	768 x 494
Sensing area	1/3 type format (4.8 x 3.6 mm)
Signal system	NTSC
Sync. System	LL
Horizontal resolution	480 TV lines
Lens mount	CS mount
Minimum illumination	0.8 lx at F1.2 (50 IRE, AGC ON, Turbo mode)
AGC	ON (Turbo mode, up to 24 dB) or OFF switchable
CCD IRIS	1/60 to 1/100,000 s
White Balance (WB)	Auto White Balance (ATW)
Back-Light Compensation (BLC)	ON or OFF switchable
S/N ratio	50 dB or more (AGC OFF, Weight ON)
Video out	BNC, 1.0 Vp-p, 75 Ω, sync negative
Auto iris lens	DC servo
Operating temperature	-10°C to 50°C (14°F to 122°F)
Storage temperature	-40°C to 60°C (-40°F to 140°F)
Power requirements	AC 24V ±10%, 60 Hz
Power consumption	3.6 W
Weight	13 oz (355 g)
Dimensions (W x H x D)	2 3/8 x 2 1/4 x 4 3/4 inches (60 x 54 x 120 mm)
Supplied Accessories	Lens mount cap (x 1), Operating instructions (x 1)

## Rear View

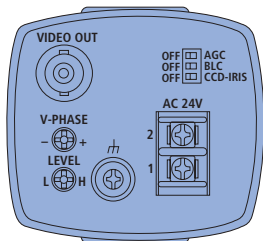

SSC-DC374

## Dimensions

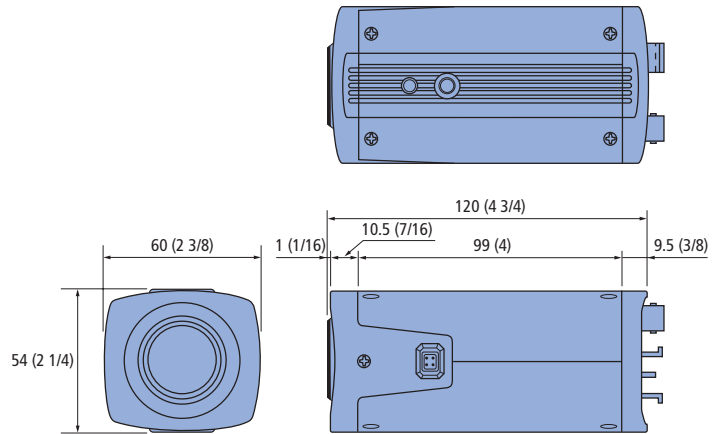

Unit: mm (inches)

# SONY®

Sony Electronics Inc.  
1 Sony Drive  
Park Ridge, NJ 07656  
[www.sony.com/security](http://www.sony.com/security)

S-SSCDC374  
MK10099V1OHB03DEC

©2004 Sony Corporation. All rights reserved.  
Reproduction in whole or in part without written permission is prohibited.  
Features, design, and specifications are subject to change without notice.

All non-metric weights and measures are approximate.  
Sony, Super HAD, CCD IRIS, Turbo AGC are trademarks of Sony.

**security**  
**systems**  
Nothing Escapes Us.™

Printed in USA (1/04)