

SONY[®]

NTSC

CCD Color Video Camera
SSC-DC314

Digital



Lens shown is optional.

High resolution camera with outstanding features

Sony introduces the SSC-DC314 1/3 type Super HAD CCD™ high resolution camera specifically designed for surveillance and monitoring applications.

The Super HAD CCD provides high resolution and sensitivity, allowing the camera to reproduce clear, identifiable pictures even in low light conditions. The SSC-DC314 also incorporates DSP (Digital Signal Processing) technology to provide a high level of stability and reliability that cannot be achieved with analog signal processing. In addition, this camera offers a host of outstanding features such as Backlight Compensation (BLC), Aperture Control, Auto Tracing White balance (ATW) and Turbo AGC™.

Offering excellent performance, with an unbeatable cost-performance ratio, the Sony SSC-DC314 camera is ideal for a wide range of demanding surveillance applications.

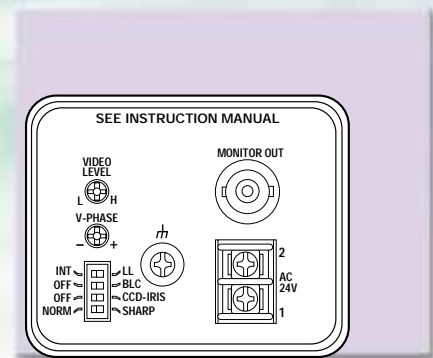

Rear Panel

O U T S T A N D I N G F E A T U R E S

High picture quality

The SSC-DC314 camera incorporates a 1/3 type IT (Interline Transfer) Super HAD CCD to give it superb horizontal resolution of 480 TV lines. Sony Super HAD CCD technology offers remarkably high sensitivity from the use of an improved microlens over each pixel of the CCD. This results in greater convergence of light onto the photo-sensitive layer of the CCD so that a light level of only 1.5 lx (F1.2 at 50 IRE) is required for clear image acquisition.

DSP Technology

The SSC-DC314 camera includes DSP (Digital Signal Processing) technology that delivers excellent picture performance. This technology also provides outstanding stability over long periods of time and a level of reliability that cannot be achieved with analog signal processing.

BLC (Backlight Compensation)

Strong backlighting can often cause the subject of the picture to be cast into shadows. The SSC-DC314 camera can automatically compensate for these backlight conditions by using Back Light Compensation (BLC) mode. This makes the subject more easily visible, providing an improved level of object recognition.

Aperture Sharp Mode

Aperture Sharp Mode makes object outlines sharper in the reproduced picture. This mode is ideal for situations where the object merges into the scene with a similar color shade. This feature is also effective when a VCR is connected as it allows sharp, crisp images to be recorded.

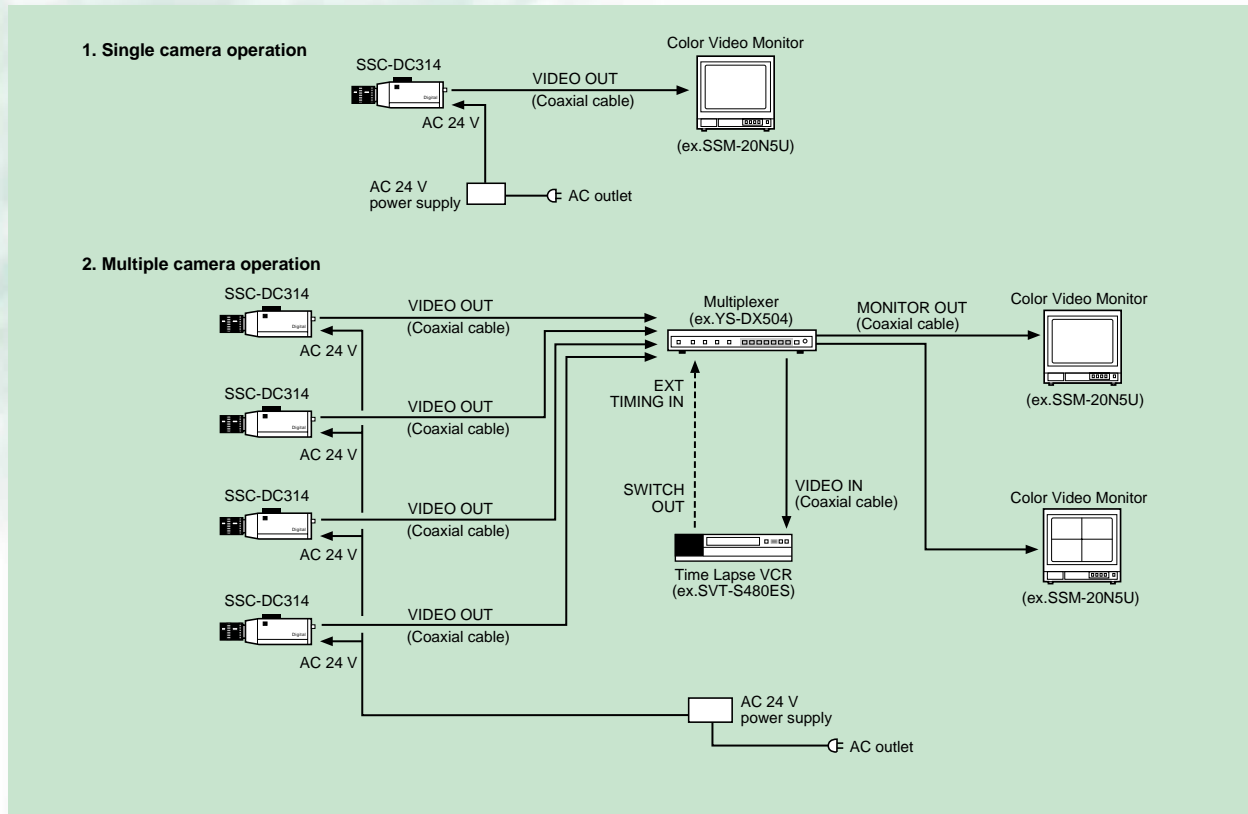

Auto Tracing White Balance (ATW)

The SSC-DC314 camera incorporates a wide-range ATW function. It adjusts the white balance automatically in response to the light conditions, such that pictures with an accurate color balance can always be obtained. The usable range of 2,000 K to 10,000 K allows the camera to be used under a wide variety of light conditions, including high-pressure, 2,100 K sodium discharge lamps that are frequently used for lighting streets, parking lots and industrial areas.

DC servo lens connection capability

This model is equipped with a supplied 4-pin auto iris connector for the attachment of popular DC servo type auto iris lenses.

CS-mount

The camera can be used with CS-mount lenses and precise back-focus adjustment can be easily accomplished. C-mount lenses also can be used with the supplied C-mount adaptor.

Turbo AGC

The SSC-DC314 camera is equipped with an advanced Turbo AGC function. This boosts the range of the cameras' AGC by up to 24 dB so that a subject under low illumination can be distinguished more clearly. The camera is permanently set to Turbo AGC.

CCD IRIS™

This function allows the use of a manual iris lens instead of a more costly automatic iris lens. As the scene illumination level varies, this camera compensates by automatically changing the exposure time of the photo sensors. This is achieved by varying the electronic shutter speed of the CCD over a range or 1/60 to 1/100,000 of a second.

SSC-DC314

Image device	1/3 type Interline Transfer Super HAD CCD
Picture elements	768 (H) x 494 (V)
Sensing area	1/3 type format (4.8 x 3.6 mm)
Signal system	NTSC standard
Sync system	INT/LL
Horizontal resolution	480 TV lines
Lens mount	CS Mount
Min. illumination	1.5 lx at F1.2 50 IRE (0.7 lx at F1.2, 30 IRE)
Aperture	Sharp/Normal
AGC	TURBO
CCD Iris	ON/OFF Switchable, 1/60 to 1/100,000 s
White balance	ATW
Backlight compensation	ON (center measured)/OFF Switchable
S/N ratio	50 dB (AGC OFF, Weight ON)
Video out	BNC, 1.0 Vp-p, 75 Ω
Operating temperature	-10 to 50°C (14 to 122°F)
Storage temperature	-40 to 60°C (-40 to 140°F)
Power requirements	AC 24 V
Power consumption	3.5W
Weight	560 g
Auto iris lens	DC
Supplied accessories	Lens connector, lens mount cap, operating instruction manual, C-mount adaptor

Dimensions 70 x 57 x 128.6 (138.5) mm (2 7/8 x 2 1/4 x 5 1/8 (5 1/2) inches)

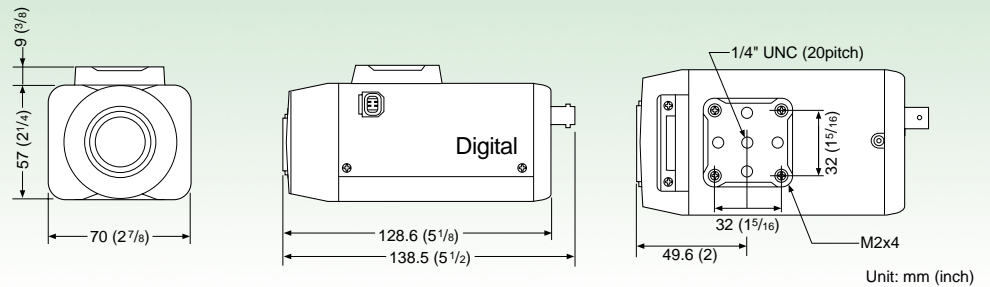

Distributed by

Sony Security Systems
 Broadcast And Professional Company
 One Sony Drive
 Park Ridge, NJ 07656-8003
 Tel: (201) 358-4954
 Fax: (201) 358-4927
www.sony.com/security

© 2001 Sony Electronics Inc. All rights reserved.
 Reproduction in whole or in part without written permission is prohibited.
 Features and specifications are subject to change without notice.
 All non-metric weights and measures are approximate.
 CCD IRIS, Super HAD CCD and Turbo AGC are trademarks of Sony Corporation.
 Sony is a registered trademark of Sony Corporation.
 All other trademarks are the property of their respective owners.