

# SONY®

EIA/NTSC

Built-in Vari-focal Lens Camera

# SSC-MX13V SSC-CX13V



**Sony introduces the SSC-MX13V and SSC-CX13V built-in vari focal lens cameras to its extensive line-up of surveillance video cameras.**

**The built-in auto iris vari-focal lens of 2.8 to 5.8 mm is equivalent to a 2x zoom lens. The focal length and focus can easily be accessed and adjusted from the top panel. In addition, the Sony original style and compact design of the cameras is perfectly suited for any commercial and fashionable facilities such as department stores, shopping malls, banks, etc.**

**As found in other Sony SSC Series cameras, necessary functions such as Turbo AGC, Backlight Compensation (BLC), ATW (for SSC-CX13V) are incorporated.**

**These cameras utilize Sony's high resolution 1/4 type Super HAD CCD™ to realize over 570 TV lines (SSC-MX13V) or 480 TV lines (SSC-CX13V) of horizontal resolution, and superb sensitivity of 0.3 lx (SSC-MX13V) or 1.8 lx (SSC-CX13V) at F1.4.**

**As for power source, these models are applicable to both DC 12 V and AC 24 V and can automatically switch to either of the two modes upon supplying power, providing flexible operation.**

**Offering excellent performance, easy set-up and sophisticated design and providing excellent cost-performance ratio, the SSC-MX13V and SSC-CX13V are the right choice for a wide range of surveillance applications.**

### **Built in auto iris vari-focal lens**

The focal length of the vari-focal lens is 2.8 to 5.8 mm, equivalent to 2x zoom. The large angle of view range: 75.9° to 37.8° (H), 56.4° to 28.4° (V) covers a wide range of viewing application requirements.

Users can easily adjust the focal length and focus at the top panel of the camera. The incorporated auto iris lens allows the camera to have a wider dynamic range, making it suitable for use in a wide variety of application.



### **Compact and Stylish design**

The compact design allows the camera to be installed in space-limited locations.

Stylish design of blue and silver is perfectly suited to various commercial and fashionable facilities, and indeed will be a good addition to them.

### **Tripod screw holes**

Tripod screw holes are already provided at the top and bottom of the camera body. Therefore, tripod adaptor is not required for set-up, realizing easy installation.



## High picture quality

Adoption of a 1/4 type Super HAD CCD allows the cameras to realize min. illumination of 0.3 lx (SSC-MX13V) or 1.8 lx (SSC-CX13V), achieve a horizontal resolution of over 570 TV lines (SSC-MX13V) or 480 TV lines (SSC-CX13V), and ensures excellent signal-to-noise ratio of 50 dB or more.

## AC 24V/DC 12V operation

The camera automatically senses and adapts to the power being supplied to it, either AC24V or DC12V, for proper operation.

## AC Line Lock Capability

These cameras feature AC line lock for external synchronization. Using the AC power frequency (60 Hz) as the vertical sync reference provides roll-free switching in multi-camera installations. These cameras also have an externally adjustable Vertical Phase ( $\pm 90^\circ$ ) control, so that completely accurate synchronization can be attained. Additionally, when DC12V power is supplied, the camera automatically switches to internal sync mode.

## AGC/Turbo AGC

AGC function boosts camera's video gain so that the subject under low illumination can be distinguished more clearly. Turbo AGC (up to 24 dB)/Normal AGC (up to 18 dB) switchable.

## BLC (Back Light Compensation)

Strong backlight can often cause the subject of the picture to be cast into shadow. BLC function compensate for such backlight conditions to make the subject more easily visible, providing an improved level of object recognition.

## Wide range ATW (SSC-CX13V)

The white balance can be automatically adjusted in response to light conditions, such that pictures with an appropriate color balance can always be obtained.

ATW color range: 2200 K to 10000 K

## DSP (SSC-CX13V)

These cameras include DSP (Digital Signal Processing) LSI (Large Scale Integration) technology to deliver excellent picture performance. This technology also provides outstanding stability over long periods of time and a level of reliability that cannot be achieved with analog signal processing.



## Typical System

### Single camera operation

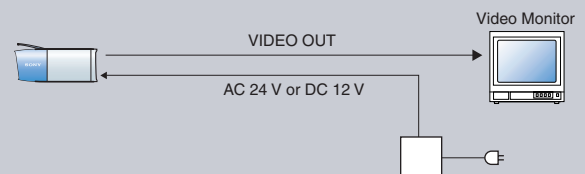

### Multiple camera operation

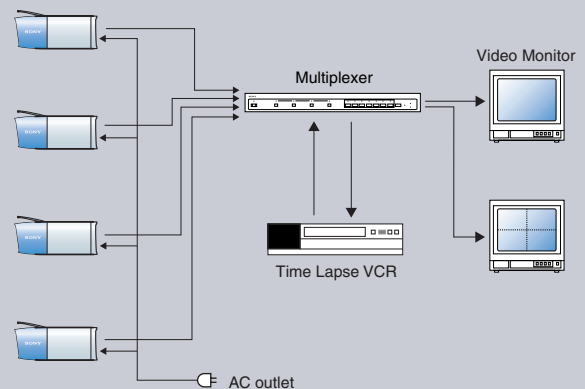

\*In case of AC 24 V/DC 12 V powered model, power supply box is needed.

# Specifications

	SSC-MX13V	SSC-CX13V
Image device	1/4 type Interline Transfer CCD	
Sensing area	1/4 type format (3.6 x 2.7 mm)	
Scanning system	525 lines 60 fields/30 frames, 2 : 1 interlaced	
Effective picture elements	768 (H) x 494 (V)	
Signal system	EIA	NTSC
Synchronization system	Internal/Line lock (AC operation) switchable	
Video signal	1.0 Vp-p, 75 Ω, negative sync	
Horizontal resolution	570 lines	480 lines
S/N ratio	More than 50 dB (AGC Off, Weight On)	
Minimum illumination	0.2 lx at F1.4 (30 IRE, AGC ON, TURBO ON) 0.3 lx at F1.4 (50 IRE, AGC ON, TURBO ON)	1.1 lx at F1.4 (30 IRE, AGC ON, TURBO ON) 1.8 lx at F1.4 (50 IRE, AGC ON, TURBO ON)
AGC	On/Off switchable, Turbo AGC/Normal AGC switchable	
White balance	—	ATW (2200 to 10000 K)
BLC	ON (Center measured)/OFF switchable	
Built-in lens	Vari-focal lens (f = 2.8 to 5.8 mm, F1.4)	
View angle	Wide: 95.7° (D), 75.9° (H), 56.4° (V) Tele: 47.3° (D), 37.8° (H), 28.4° (V)	
Minimum object distance	0.2 m	
Iris	Auto iris	
Power requirement	AC 24 V ±10 % (50 Hz) or DC 10.8 to 15.6 V for power source	
Power consumption	1.8 W	3.0 W
Dimension	58 (W) x 54 (H) x 133 (D) mm	
Mass	Approx. 250 g	
Operating temperature	-10°C to +50°C (14°F to 122°F)	
Storage temperature	-40°C to +60°C (-40°F to 140°F)	
Operating Humidity	20 % to 80 %, Non-condensing	
Storage Humidity	20 % to 95 %, Non-condensing	
Supplied accessories	Operation instruction	

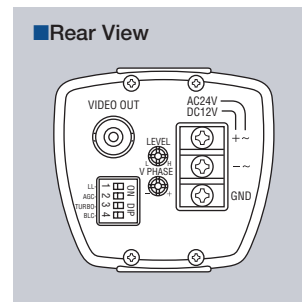
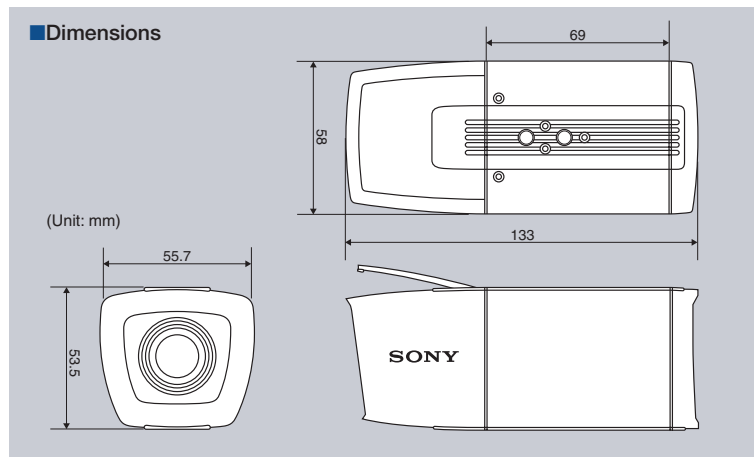

# SONY

Sony Security Systems  
Broadcast and Professional Company  
One Sony Drive  
Park Ridge, NJ 07656-8003  
Tel: (201) 358-4954  
Fax: (201) 358-4927  
www.sony.com/security

S-SSCMX13V/CX13V  
Printed in USA 12/01

© 2002 Sony Corporation. All rights reserved.  
Reproduction in whole or in part without written permission is prohibited.  
Features and specifications are subject to change without notice.  
All non-metric weights and measures are approximate.  
Super HAD CCD is a trademark of Sony Corporation.  
Sony is a registered trademark of Sony Corporation.  
All other trademarks are the property of their respective owners.

