

SONY

3-751-856-22 (1)

CCD Color Video Camera

SSC-S20

Operating Instructions

Before operating the unit, please read this manual thoroughly and retain it for future reference.

Owner's Record

The model and serial numbers are located on the bottom.
Record the serial number in the space provided below. Refer to these numbers whenever you call upon your Sony dealer regarding this product.

Model No. SSC-S20

Serial No. _____

WARNING

To prevent fire or shock hazard, do not expose the unit to rain or moisture.

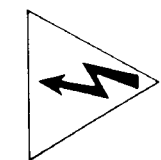
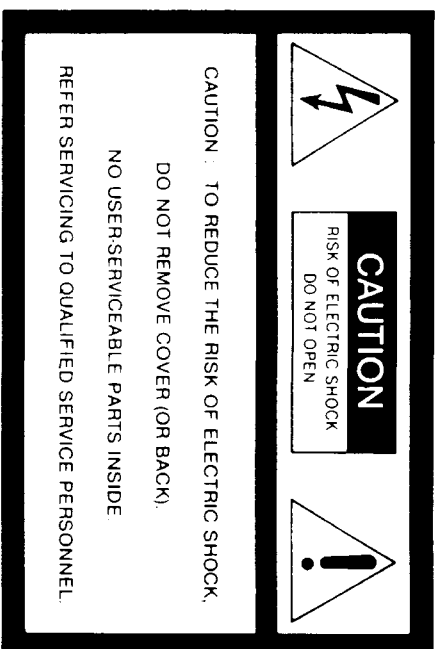

This symbol is intended to alert the user to the presence of uninsulated "dangerous voltage" within the product's enclosure that may be of sufficient magnitude to constitute a risk of electric shock to persons.

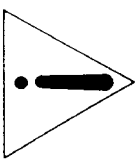

This symbol is intended to alert the user to the presence of important operating and maintenance (servicing) instructions in the literature accompanying the appliance.

* The graphical symbols are on the bottom enclosure.

2

Warning — This equipment generates, uses, and can radiate radio frequency energy and if not installed and used in accordance with the instructions manual, may cause interference to radio communications. It has been tested and found to comply with the limits for a Class A computing device pursuant to Subpart J of Part 15 of FCC Rules, which are designed to provide reasonable protection against such interference when operated in a commercial environment. Operation of this equipment in a residential area is likely to cause interference in which case the user at his own expense will be required to take whatever measures may be required to correct the interference.

Important- To insure that the complete system (including this peripheral) is capable of complying with the FCC requirements, it is recommended that the user make sure that the individual equipment of the complete system has a label with one of the following statements.

"This equipment has been tested with a Class A Computing Device and has been found to comply with Part 15 of FCC Rules."

-or-

"This equipment complies with the requirements in Part 15 of FCC Rules for a Class A Computing Device,"
-or equivalent.

For the customers in Canada

This apparatus complies with the Class A limits for radio noise emissions set out in Radio Interference Regulations.

3

Table of Contents

Introduction	5
Features	5
How to use this manual	5
Precautions	6
Location and function of parts and controls	8
Preparations	12
Attaching a lens	12
Connections	13
Setting the BACK UP switch	16
Adjustments	17
Setting the date and time	17
Selecting the automatic/manual adjustment	18
Indications in manual adjustment mode	19
Adjusting the white balance	20
Setting the shutter speed	21
Adjusting the gain	21
Setting the camera ID number	22
Correcting the phase differences of cameras	23
Specifications	back cover

Introduction

Features

The SSC-S20 is a color video camera which uses a 1/2" CCD (Charge Coupled Device), a solid state image sensor of 410,000 picture elements.

Its features are:

- A high resolution picture of 460 TV lines is obtained.
- The minimum sensible illumination of 4 lux with F1.2 allows use of the camera in a dark place.
- A high signal-to-noise ratio of more than 46 dB is achieved.
- A standard C mount lens can be attached.
- Date/time, white balance, shutter speed and AGC ON/OFF modes and camera ID number are visible on the monitor screen.
- An S VIDEO OUT connector ensures better quality picture.
- The gen-lock mode is available for operating multiple cameras on the same sync signal.

How to Use This Manual

This manual consists of the following five sections.

- 1 Precautions
- 2 Location and function of parts and controls
- 3 Preparations
- 4 Adjustments
- 5 Specifications

Anyone who uses this camera is first requested to read "Precautions" carefully.

Then, if you install the camera by yourself, read from "Preparations". If you have your camera installed by your Sony dealer or service engineer, read "Adjustments" only when you need.

"Location and function of parts and controls" and "Specifications" are useful to familiarize yourself with this camera.

Precautions

Safety

- This unit operates on 24 V AC or 12 V DC.
- When using this unit on 24 V AC, use the transformers which are UL listed as Class 2.
- An irregular voltage may be generated in the AC power cord and may cause malfunction and/or damage to the unit. In order to avoid such an accident, ground the unit.

Installation

- Allow adequate air circulation to prevent internal heat build-up.
- Do not install the unit near heat sources such as radiators or air ducts or in a place subject to direct sunlight or strong vibration.
- Do not install the unit near TV or radio station which radiates high power radio waves.

Operation

- Avoid shooting a very bright object such as illuminations for a long time.
- Avoid rough handling or mechanical shock.
- Operate the video camera within a -10°C to $+40^{\circ}\text{C}$ (14°F to 104°F) temperature range.

Special characteristics of a CCD

Due to the use of the CCD, the following phenomenon may be observed.

- When a very bright object such as an electric light, fluorescent lamp, sunlight and strong reflected light is shot, a smear (light belt-like line) may appear around the image of the object on the screen.
- When the unit is operated at a high temperature, patterned noise may appear uniformly over the entire monitor screen.
- When fine stripes, straight lines, etc. are shot, the image displayed on the screen may appear wavy.

Cleaning

- Clean the lens and filter with a blower or lens tissue.
- Clean the cabinet, panel and controls with a dry soft cloth, or soft cloth lightly moistened with mild detergent solution. Do not use any type of solvent, such as alcohol or benzene, which might damage the finish.

If you have any questions about this unit, contact your authorized Sony dealer.

Location and Function of Parts and Controls

For details on the use of each part, refer to the pages indicated in ●.

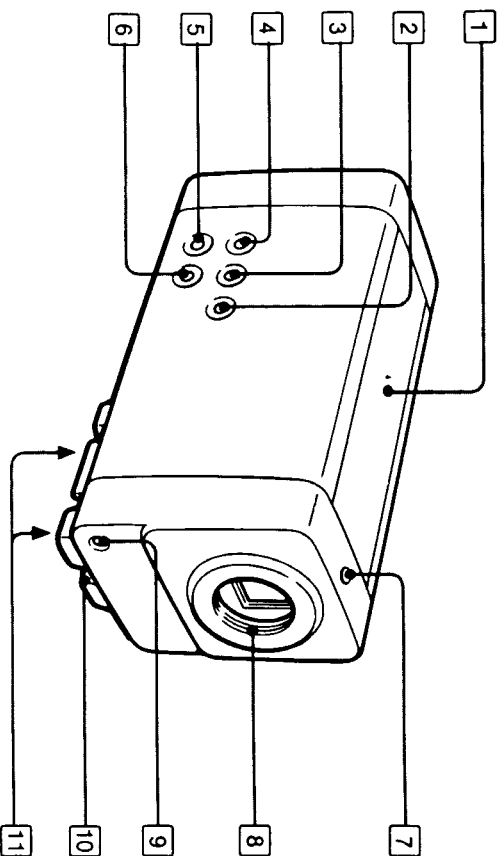

- 1 **Top panel**
For the internal switches, see page 11.
- 2 **AGC (Automatic Gain Control) button** ●
When the MODE selector is set to ADJ, press this button to set the AGC circuit to ON or OFF.
- 3 **SHUTTER SPEED button** ●
When the MODE selector is set to ADJ, press this button to set the shutter speed to 1/60, 1/100, 1/250, 1/1000, 1/2000, 1/4000 or 1/10000 second.
- 4 **WHITE BALANCE button** ●
When the MODE selector is set to ADJ, press this button to set the white balance mode to AUTO, HOLD, ● (5,800 K) or ● (3,200 K).
- 5 **DATE/TIME button** ●
When the MODE selector is set to ADJ, press this button to set the date and time. After setting, select the date and/or time display mode.

8

- 6 **SET button** ●
When adjusting the date and time, first press this button for about 3 seconds to set the unit to the setting mode.
During setting, press this button to proceed to the next item.
- 7 **Flange focal length adjustment screw**
If necessary, turn this screw to adjust the flange focal length with a screwdriver. This screw has a lock mechanism so that the flange focal length is not misaligned by vibrations, etc.
- 8 **Lens mount**
Attach a C mount lens.
- 9 **Power lamp**
Lights in red when the power is supplied to the unit.
- 10 **Mount adaptor**
This adaptor can be attached to either the top or bottom of the unit.
- 11 **Mounting screw holes (U1/4" – 20UNC)**
φ : ISO standard 4.5 mm ±0.2mm
ASA standard 0.197 inches
Max: 9mm (3/8 inches)

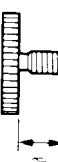

9

Location and Function of Parts and Controls

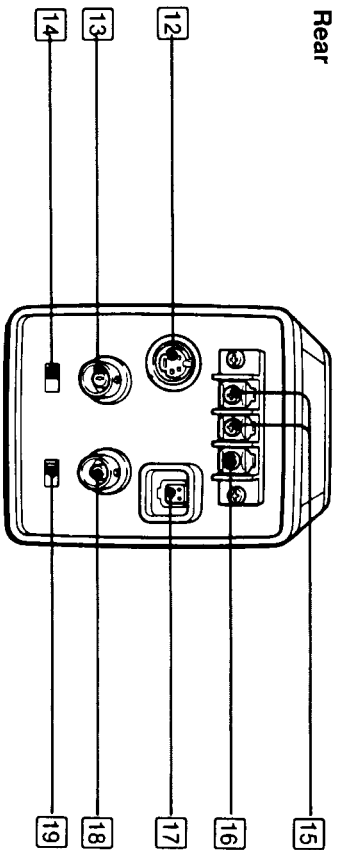

- 12 S VIDEO OUT connector (4-pin mini DIN)**
Connect to the S VIDEO IN connector of a video monitor.
- 13 VIDEO OUT connector (BNC)**
Connect to the composite VIDEO IN connector of a video monitor.
- 14 T.D. DISPLAY (time/date display) switch**
Set this switch to ON to display the time and date indications on the monitor screen.
- 15 AC 24 V IN/DC 12 V IN terminals**
Connect to an AC 24 V or 12 V DC power source.
- 16 GND (chassis ground) terminal**
- 17 LENS connector**
Connect the cable of an auto iris lens.
- 18 GEN LOCK IN connector (BNC)**
Connect to a sync generator.
- 19 MODE selector**
LOCK: The pre-adjusted modes are locked and the buttons [2] through [6] are inoperative.
ADJ (adjust): Set to this position when changing the white balance mode, shutter speed, AGC setting and time/date.
AUTO: Automatic adjustment mode. The white balance is adjusted automatically, the shutter speed is fixed to 1/60 sec. and the AGC circuit is activated.

10

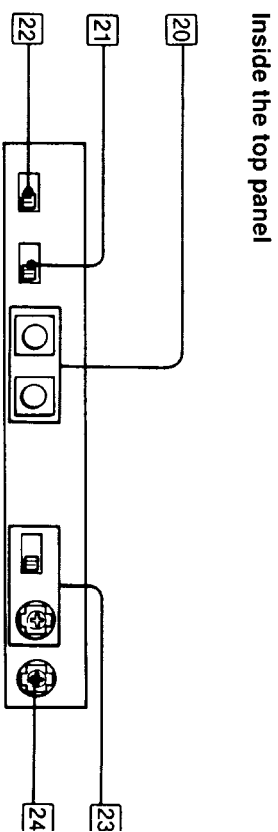

- 20 CAMERA ID NO. buttons**
Set the camera ID number between 1 and 99.
- 21 CAMERA ID NO. switch**
Set this switch to ON to display the camera ID number on the monitor screen.
- 22 BACK UP switch**
Set this switch to ON to activate the memory backup battery.
- 23 SC (subcarrier) PHASE switch and control**
Adjust the hue difference of individual video cameras.
- 24 H (horizontal) PHASE control**
Adjust the horizontal phase difference of individual video cameras.

11

Preparations

Attaching a Lens

Any C mount lens with the following conditions can be attached to the camera.

- A lens with a projection from the lens mount of 8 mm (11/32 inches) or less.
- A lens which can be operated on 10 V DC (50 mA max.).

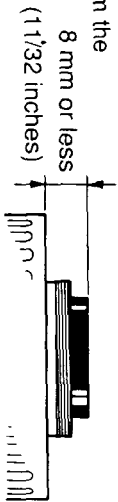

— A lens with incorporated video amplifier, so that the video output is detected.

— A lens which can be operated on 10 V DC (50 mA max.).

Procedure

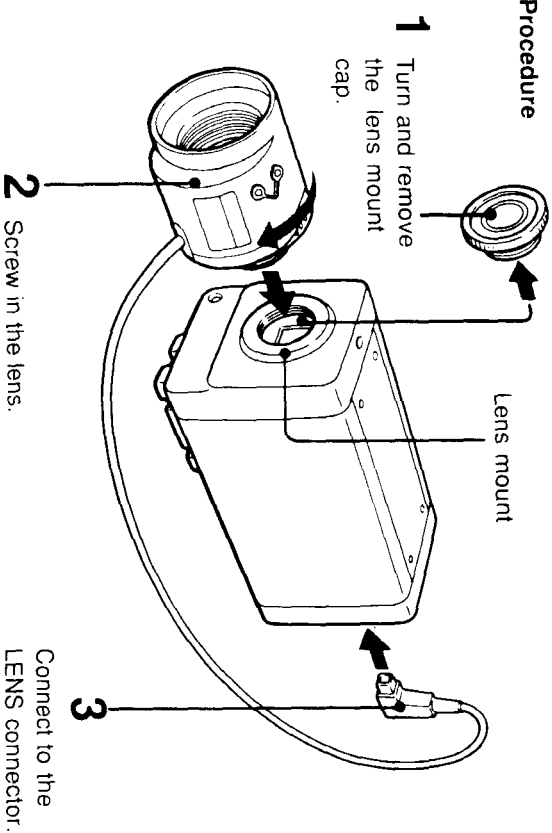

- 1 Turn and remove the lens mount cap.
- 2 Screw in the lens.
- 3 Connect to the LENS connector.

12

Connections

Connection example 1 : Connecting a video monitor equipped with an S VIDEO input

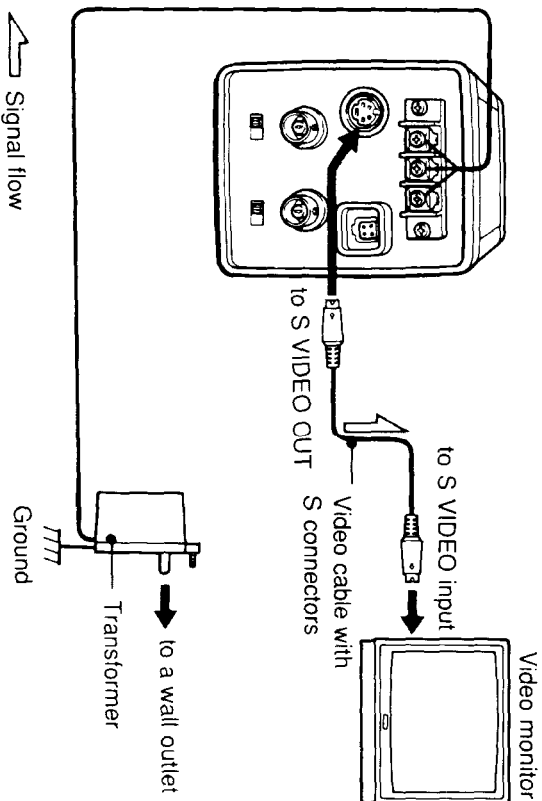

Required transformer

When operating the unit on AC power source, always connect the transformer (UL listed as Class 2). Connect the transformer to a wall outlet after all connections have been completed.

13

Preparations

Connection example 2 : Connecting a video monitor not equipped with S VIDEO input

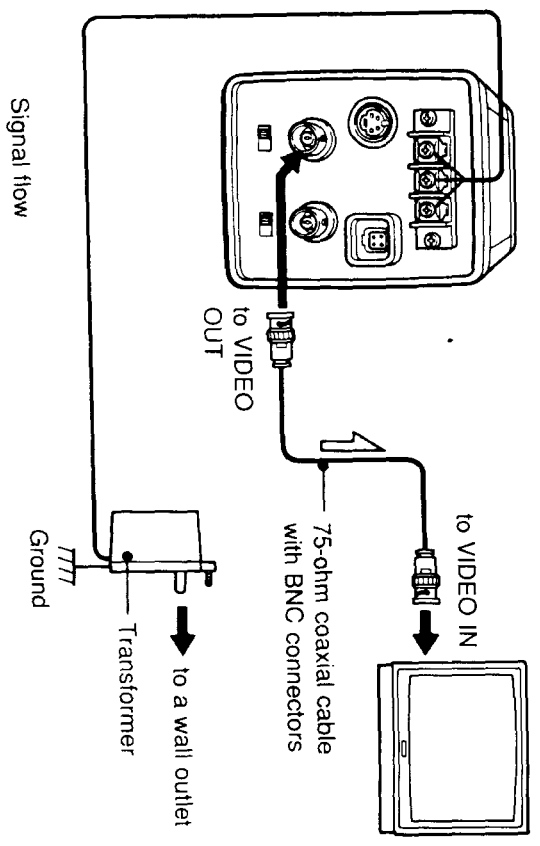

Connection example 3 : Connecting video cameras to a camera switcher and operating with the same sync signal

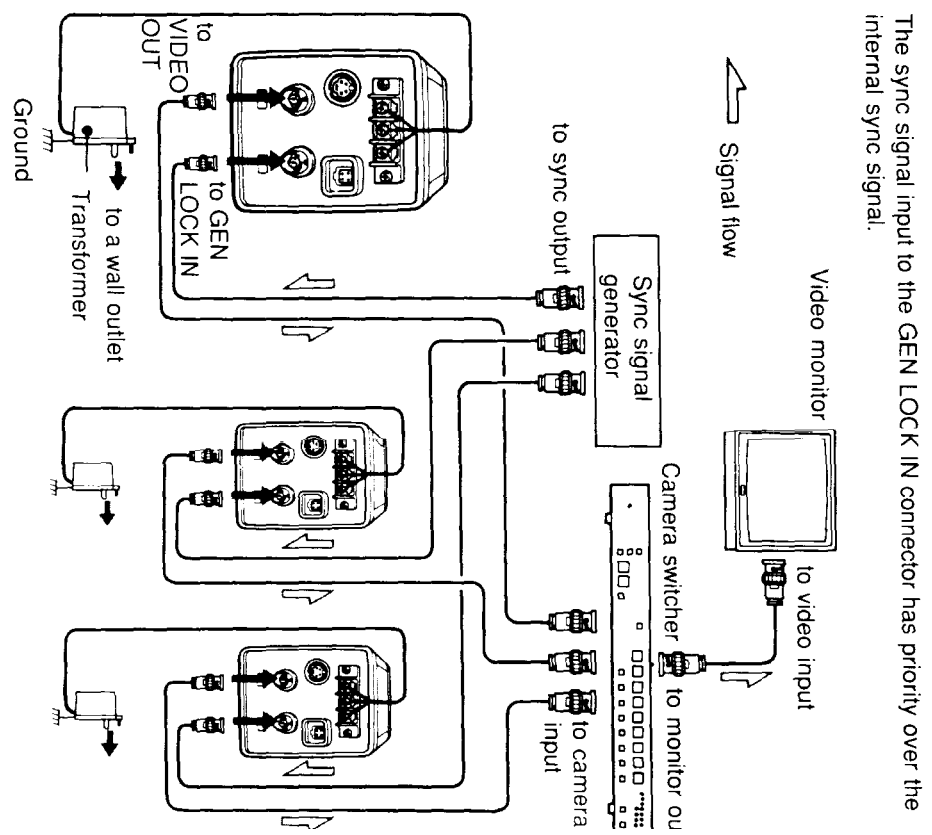

The sync signal input to the GEN LOCK IN connector has priority over the internal sync signal.

For details, refer to the operating instructions of the camera switcher.

Preparations

Setting the BACK UP Switch

This camera incorporates a lithium battery to back up the clock and the memory of the camera ID number and adjusted operation modes for about two weeks in case of a power interruption.

The BACK UP switch is set to OFF at the factory. To activate the backup battery, set it to ON with the following procedure:

Procedure

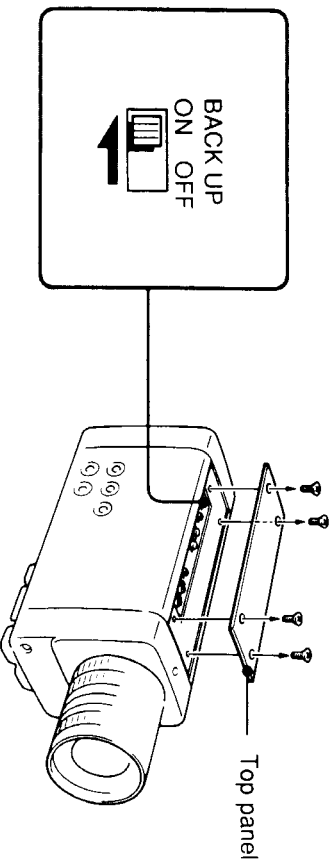

- 1 Remove the four screws and the top panel.
- 2 Turn the power of the camera on.
- 3 Set the BACK UP switch to ON.
- 4 Replace the top panel.

Set the BACK UP switch to OFF:

- when you will not use the camera for more than one month.
- when you use the camera in automatic adjustment mode without displaying the date and time indications on the monitor screen.

Caution

Before switching the BACK UP switch from OFF to ON, make sure that the power of the camera is turned on.

Otherwise, the camera may not operate properly.

If you should have set the BACK UP switch to ON with the power off, reset it to OFF, turn the power on and set it to ON again.

16

Adjustments

Setting the Date and Time

You can display the date and the current time on the monitor screen.

Procedure

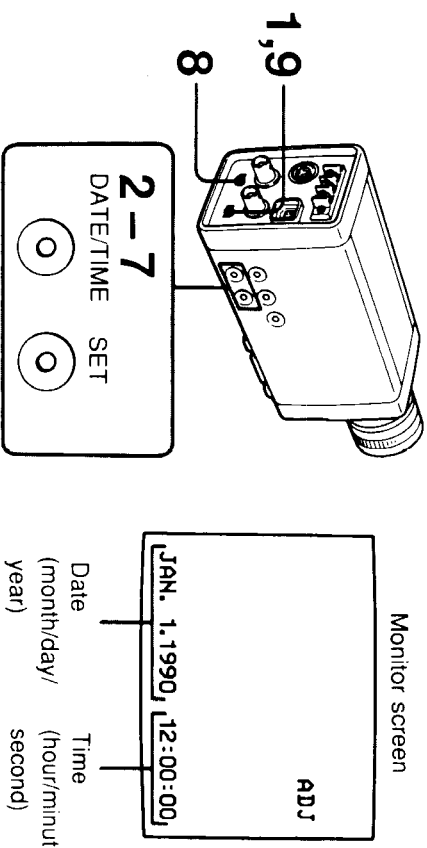

- 1 Set the MODE selector to ADJ. The "ADJ" indication appears and "JAN. 1.1990 12:00:00" blinks on the monitor screen.
- 2 Press the SET button for about 3 seconds until the year indication blinks.
- 3 Press the DATE/TIME button until the current year is indicated.
- 4 Press the SET button. The month indication blinks.
- 5 Set the month, day, hour and minute in sequence by pressing DATE/TIME until the desired indication blinks and then press SET to proceed to the next item.
- 6 When the second digits blink, press the SET button. The clock starts from 00 second.

Continued on next page.

17

Adjustments

7 Press the DATE/TIME button to select the date/time display mode. Each time the button is pressed, the display changes cyclically as follows:

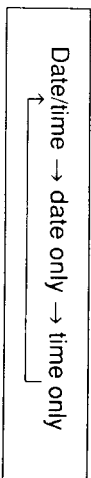

- 8 Set the T.D. DISPLAY switch to ON.
- 9 Set the MODE selector to LOCK or AUTO, as required.

To turn off the date/time indications

Set the T.D.DISPLAY switch to OFF.

Selecting the Automatic/manual Adjustment

When the MODE selector is set to AUTO (automatic adjustment mode), the white balance and gain are adjusted automatically according to the shooting situation, and the shutter speed is fixed to 1/60 second.

When the manual adjustments are required, set the MODE selector to ADJ, and adjust each item as described later.

If you set the MODE selector to LOCK after the adjustment, the adjusted modes are locked and the adjustment buttons become inoperative.

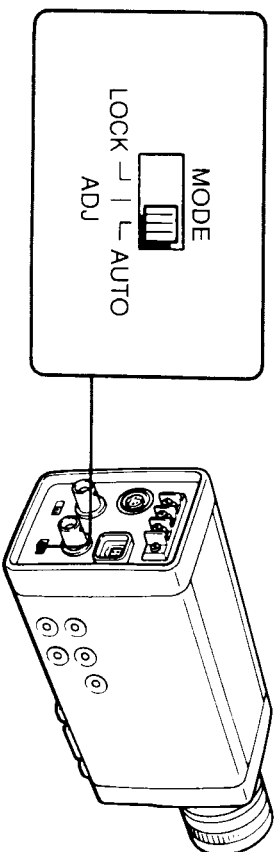

18

Indications In Manual Adjustment Mode

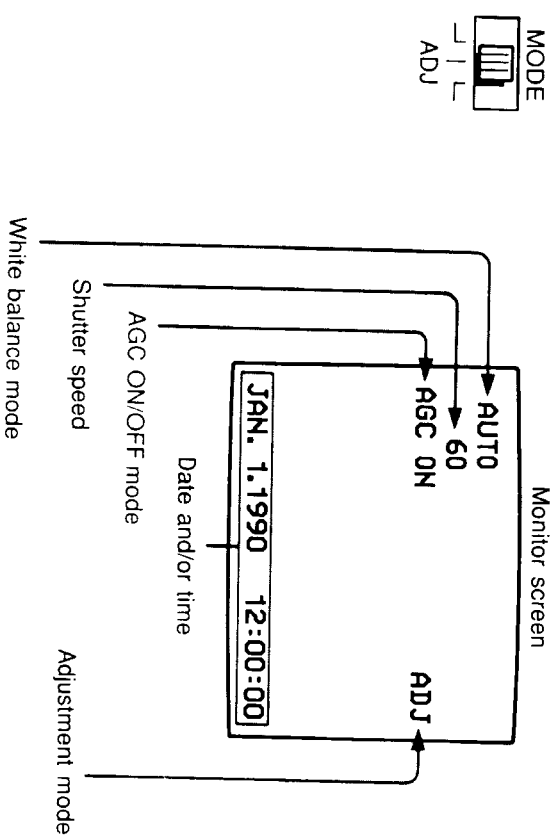

Note

If the BACK UP switch is set to OFF or the built-in backup battery is exhausted, the adjusted and locked modes are canceled and the unit is returned to the automatic adjustment mode: the "JAN. 1. 1990. 12:00:00" indication blinks if the T.D. DISPLAY switch is set to ON. In this case, set the BACK UP switch to ON with the power of the camera on, or consult the qualified service personnel.

19

Adjusting the White Balance

Four white balance modes can be selected.

AUTO : To track a white color according to the change in lighting conditions. Normally set to this position.

HOLD : To keep the white balance with a specified white.

5800 K : To use the unit outdoors on a clear day.

3200 K : To use the unit indoors under an incandescent lamp.

- 1 Set the MODE selector to ADJ.
- 2 Press the WHITE BALANCE button so that the desired white balance mode indication appears on the monitor screen. Each time the button is pressed, the indication changes cyclically as follows:

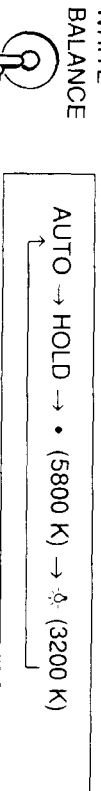

- 3 Set the MODE selector to LOCK.

To keep the white balance with a specified white

- 1 Set the MODE selector to ADJ.
- 2 Press the WHITE BALANCE button so that the AUTO indication appears.
- 3 Point the camera to a white object.
- 4 Press the WHITE BALANCE button so that the HOLD indicator appears. The correct white balance is memorized.
- 5 Set the MODE selector to LOCK.

Setting the Shutter Speed

Shutter speed can be set to 1/60, 1/100, 1/250, 1/1000, 1/2000, 1/4000 or 1/10000 second.

Choose an appropriate shutter speed according to the object and shooting situation.

- 1 Set the MODE selector to ADJ.
- 2 Press the SHUTTER SPEED button until the desired shutter speed indication appears on the monitor screen. Each time the button is pressed, the indication changes cyclically as follows:

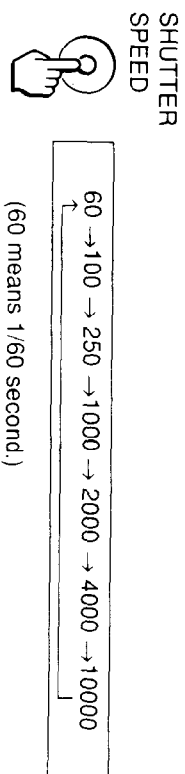

- 3 Set the MODE selector to LOCK.

Adjusting the Gain

When the AGC (Automatic Gain Control) is set to ON, the output amplitude gain changes according to the object to be shot. It can be set to OFF to fix the output amplitude gain.

- 1 Set the MODE selector to ADJ.
- 2 Press the AGC button so that the AGC ON or AGC OFF indication appears as required.

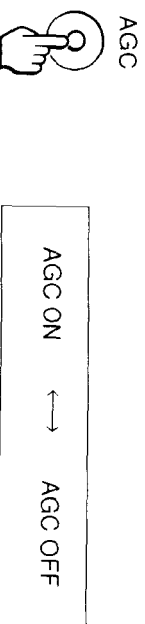

- 3 Set the MODE selector to LOCK.

Setting the Camera ID Number

When multiple cameras are used, you can set and display the camera ID number 1 through 99 on the monitor screen.

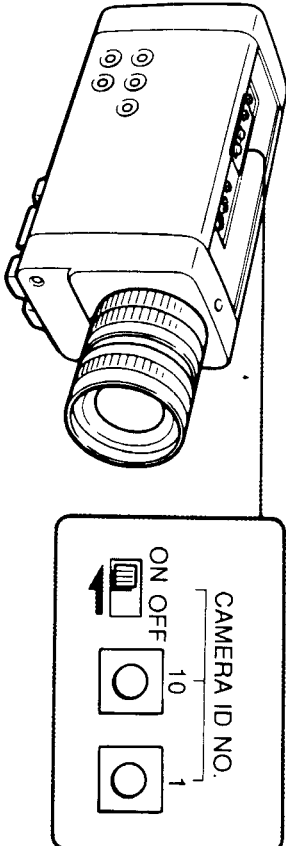

- 1 Remove the four screws and the top panel.
- 2 Set the CAMERA ID NO. switch to ON. "NO.1" appears on the monitor screen.
- 3 Set the desired number with the CAMERA ID NO. buttons 10 and 1. Press 10 to set the ten's digit, and press 1 to set the unit's digit.
- 4 Replace the top panel.

To turn off the camera ID number indication
Set the CAMERA ID NO. switch to OFF.

Correcting the Phase Differences of Cameras

When multiple cameras are operated with the same sync signal, you can correct the horizontal phase (horizontal position of the image) difference and the subcarrier phase (hue) difference between the cameras.

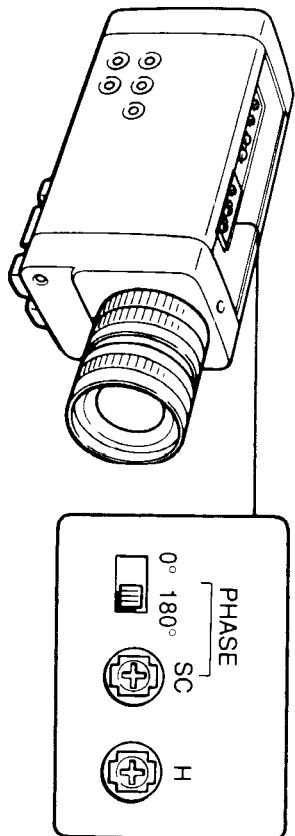

- 1 Remove the four screws and the top panel.
- 2 Adjust the phase.
 - Horizontal phase:** Turn the H PHASE control.
 - Subcarrier phase:** Set the SC PHASE selector to 0° or 180° and then turn the SC PHASE control.
- 3 Replace the top panel.

Specifications

Pickup device	Interline-transfer CCD	Composite video output	BNC connector
Pickup device		1 Vp-p, sync negative, 75 ohms	
Picture elements	380,000 (effective)	S VIDEO output	4-pin mini DIN
Sensing area	6.5 mm x 4.8 mm (effective) (equivalent to 1/2-inch pickup tube)	Signal-to-noise ratio	46 dB (with AGC OFF)

Optical and video

Lens mount	C mount
Lens connector pin assignment	
	1 Power (10 V DC, 50 mA max.)
	2 GND
	3 Open
	4 Video signal (V) (auto iris control signal)

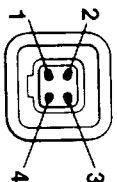

Video signal	EIA standard, NTSC color	Operating humidity	-20°C to +60°C (-4°F to +140°F)
Scanning system	525 lines, 2:1 interlace	Storage humidity	Less than 70%
Sync system	30 frames/sec. Internal/external, automatically switchable	Shock resistance	Less than 90% 70 G
External sync signal	Gen-lock VBS, BS (V.H LOCK)	Dimensions	Approx. 64 x 82 x 154 mm (w/h/d) (2 5/8 x 3 1/4 x 6 7/8 inches)
	Sync level 0.3 Vp-p, ±6 dB, 75 ohms terminated	Weight	Approx. 700 g (1 lb 9 oz)
Horizontal resolution	More than 460 TV lines	Supplied accessories	Lens mount cap (1) Mounting adaptor (1) Auto iris lens connector (1)
Minimum illumination	4 lux with F1.2		

Design and specifications are subject to change without notice.