



Date: January 4, 1996

To: John Evans

From: Ed Kickham
Starin Marketing

Re: Sony Security

John, as discussed, here are the lux rating specs on both the SPT-M104A and the SPT-M304:

SPT-M104A

Measurement conditions: F1.2/AGC ON

100 IRE	0.74 lux
50 IRE	0.2 lux
20 IRE	0.06 lux
15 IRE	0.04 lux

SPT-M304

Measurement conditions: F1.2

50 IRE	0.5 lux
20 IRE	0.06 lux
15 IRE	0.03 lux

Measurement conditions: F0.75

50 IRE	0.19 lux
20 IRE	0.02 lux
15 IRE	0.01 lux

Please share w/ the other guys.

SONY

CAMERA

SPT-M104A/1

**MONOCHROME
VIDEO
CAMERA**

1/3" Hyper HAD™ CCD Imager
High sensitivity (0.1 lux* at F1.2)
Wide range CCD IRIS™-1/60 to 1/100,000 second
Auto iris lens capability (DC Driven)
Backlight Compensation (BLC) capability
Accepts C and CS mount lenses
Compact design: 123 mm (4-7/8") length
Newly designed AC Line lock synchronization with V-phase

SPT-M104A/1

24V AC



**EVT-820
8mm TAPE LAPSE
VIDEORECORDER**

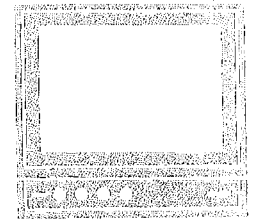

**SSM-930
9" B/W MONITOR**

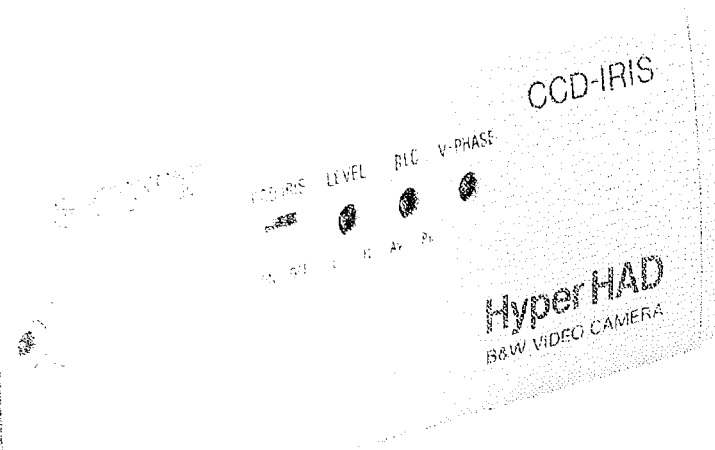
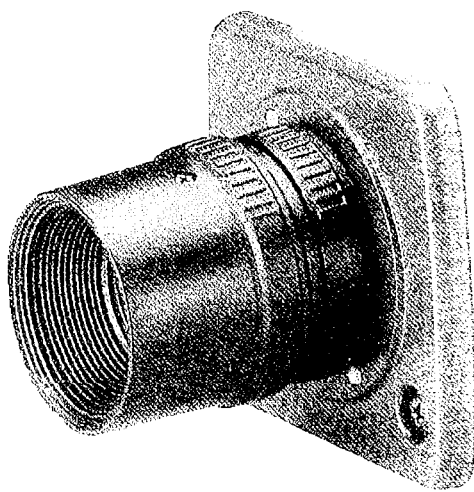

Hyper HAD™

**SONY
SECURITY
SYSTEMS**
NOTHING ESCAPES US™

SPT-M104A/1

**MONOCHROME
VIDEO
CAMERA**

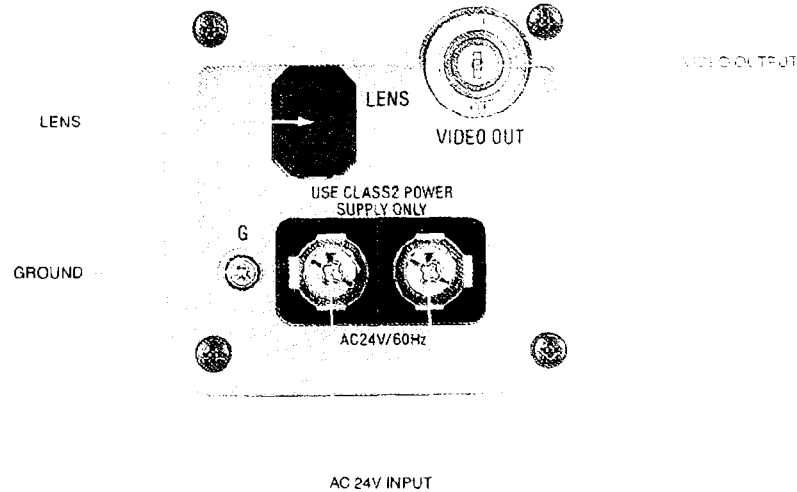
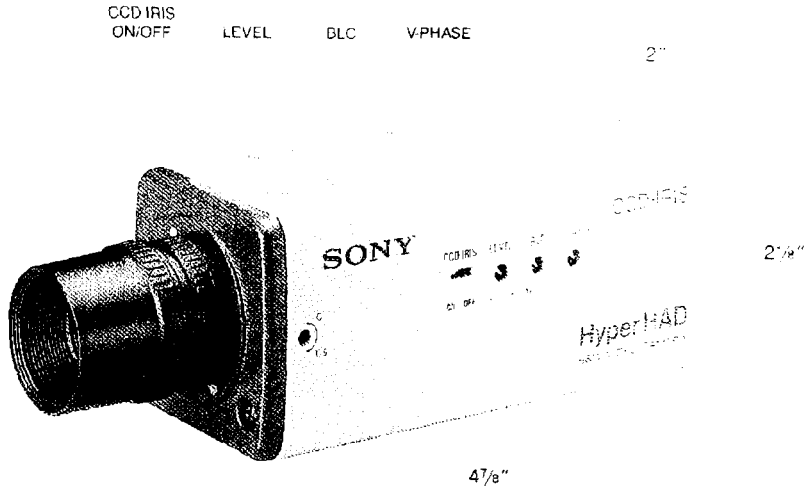

SPT-M104A/1

Image Pickup Device: 1/3" HyperHAD™ Interline Transfer CCD

Picture Elements (H x V): 510 x 492

Sensing Area (H x V): 4.4mm x 3.3mm

Lens Mount: C/CS-mount (back focus adjustable)

Signal System: EIA standard

Scanning System: 525 lines, 2:1 interlace

Synchronization: AC line lock

Phase Control: V-Phase ±90°

Horizontal Resolution: 380 lines

Minimum Illumination: 0.1 lux at F1.2

CCD IRIS: 1/60 to 1/100,000 second

Controls:

CCD IRIS On/Off switchable

Level variable

BLC adjustable

Video Output: 1Vpp, 75 Ohms, sync negative

Video S/N: over 45dB, AGC ON

Connectors:

AC IN 24V terminals

Video out BNC X1

Auto Iris connector 4 pin

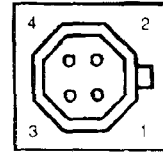

PIN	SIGNAL
1	BRAKE (-)
2	BRAKE (+)
3	DRIVE (+)
4	DRIVE (-)

Power Requirements: 24V AC, 60 Hz

Power Consumption: 4.5W

Operating Temperature: 14°F to 122°F (-10°C to +50°C)

Storage Temperature: -40°F to 140°F (-40°C to +60°C)

Dimensions (WHD): 2 1/8" x 2" x 4 7/8" (53 x 50 x 123mm) excluding projecting parts

Weight: 11 oz. (300 grams)

Supplied Accessories: Lens connector
Lens mount cap
Instruction manual

© 1993 Sony Electronics Inc.
Reproduction in whole or in part without written permission is prohibited.
All rights reserved.
All features and specifications are subject to change without notice.
All non-metric weights and measurements are approximate.

Sony, CCD IR S, HyperHAD, and Nothing Escapes Us are trademarks of Sony.

*Minimum Illumination: There is no industry-standardized procedure for testing minimum illumination; specifications should only be compared with models of the same manufacturer.

SONY

Sony Security Systems
Business and Professional Group
3 Paragon Drive
Montvale, New Jersey 07645
TEL: (201) 358-4954 • FAX: (201) 358-4927

Printed in U.S.A. 6/94 SS-SPTM104A/1

**SONY
SECURITY
SYSTEMS**
NOTHING ESCAPES US.