

SONY

PROPERTY OF SONY
MIDWEST REGION

5/11 100070

3-755-415-21 (2)

UHF Synthesized Wireless Microphone

Model:

WRT-830A

Operating Instructions Page 2

Before operating the unit, please read this manual thoroughly and retain it for future reference.

Manual de instrucciones Página 21

Antes de utilizar la unidad, lea detenidamente este manual de instrucciones, y consérvelo para futuras referencias.



© 1992 by Sony Corporation

Owner's Record

The model number is located at the grip end and the serial number inside the grip. Record the serial number in the space provided below. Refer to these numbers whenever you call upon your Sony dealer regarding this product.

Model No. WRT-830A Serial No. _____

WARNING

To prevent fire or shock hazard, do not expose the unit to rain or moisture.

To avoid electrical shock, do not open the cabinet. Refer servicing to qualified personnel only.

Notice for customers in the U.S.A.

Use of Sony wireless devices is regulated by the Federal Communications Commission as described in Part 74 subpart H of the FCC regulations and users authorized thereby are required to obtain an appropriate license.

You are cautioned that any changes or modifications not expressly approved in this manual could void your authority to operate this equipment.

Table of Contents

Introduction	4
Features	5
Precautions	6
Parts Identification	7
Inserting Batteries	9
Changing the Channel Selection	10
Changing the Input Attenuation Setting	12
Using the Microphone	15
Specifications	16
Channels and Carrier Frequencies	17
Block Diagram	18
Frequency Response	19
Directivity	20

Introduction

The WRT-830A is a wireless microphone for an 800MHz band UHF synthesized wireless microphone system to be used for broadcast or movie production purpose. The other system components include the WRT-810A UHF synthesized wireless microphone, the WRT-820A UHF synthesized transmitter, the AN-820A UHF antenna, the WD-820A UHF antenna divider, and the WRR-820A/840A UHF synthesized diversity tuner. The microphones/transmitters and tuners are classified by frequency band. See the table below.

A 12 MHz frequency band (or two consecutive-numbered TV channels) is assigned to each microphone/transmitter and tuner model. To indicate the assigned frequency bands, the parenthesized numbers following the model names in the table show the smaller of the assigned TV channel numbers.

Frequency band		Model name			
TV channel	Frequency (MHz)				
64	770.125 — 775.875	WRT-810A(64) WRT-820A(64)	AN-820A	WD-820A	WRR-820A(64) WRR-840A(64)
65	776.125 — 781.875				
66	782.125 — 787.875	WRT-810A(66) WRT-820A(66)			WRR-820A(66) WRR-840A(66)
67	788.125 — 793.875				
68	794.125 — 799.875	WRT-810A(68) WRT-820A(68) WRT-830A(68)			WRR-820A(68) WRR-840A(68)
69	800.125 — 805.875				

Features

High quality sound recording with low handling noise

The unit employs back-electret condenser capsule, which allows recording of vocals in superb sound quality. The anti-vibration structure of the capsule also reduces the handling noise drastically.

Easy selection of 94 channels

With its sophisticated phase locked loop (PLL) circuit, the unit can operate on any one of 94 carrier frequencies selected by a simple button operation.

Operation powered by widely available batteries

The built-in DC-DC converter allows stable operation, for about eight hours continuously, with just two L40 (LR6) alkaline batteries.

CPU and LCD for coordinated operation control

The built-in CPU controls the unit operation including the PLL circuit function. The LCD shows the current channel number, the residual battery power, the input attenuation setting, the AF input level and the RF output.

Saved channel and input attenuation settings

The unit stores the channel and the input attenuation settings when it is turned off. The saved settings are retained even if the batteries are removed. Therefore, when using the unit next time, you need not make the same settings again.

Highly reliable electronic attenuator

The built-in input level attenuator is adjustable in the range of 0 to 12 dB in 3-dB steps. It reduces signal distortion when an excessively strong input signal is received.

RF carrier with tone signal

The unit transmits the RF carrier accompanied by a tone signal, enabling the tuner with a tone squelch circuit to take out only the target audio signal received.

Wide dynamic range and low noise

The compander (compressor/expander) system enables transmission over a wide dynamic range with minimum noise.

Precautions

- The unit is designed for use in an ambient temperature range of 0°C to 50°C (32°F to 122°F).
- Do not place the unit on or near a heat source such as lighting equipment or a power amplifier, or in a place subject to direct sunlight or excessive moisture. In such places, the external finish or internal parts of the unit may be damaged.
- If the unit is used in a very humid or dusty place or in a place subject to an active gas, clean its surface as well as connectors with a dry, soft cloth soon after use. Lengthy use of the unit in such places or not cleaning it after its use in such places may shorten its life.
- When cleaning the unit, never use organic solvents such as thinners or benzene, which will damage the finish of the unit.
- The unit has been factory adjusted precisely. Do not tamper with its internal parts or attempt to repair it.

Parts Identification

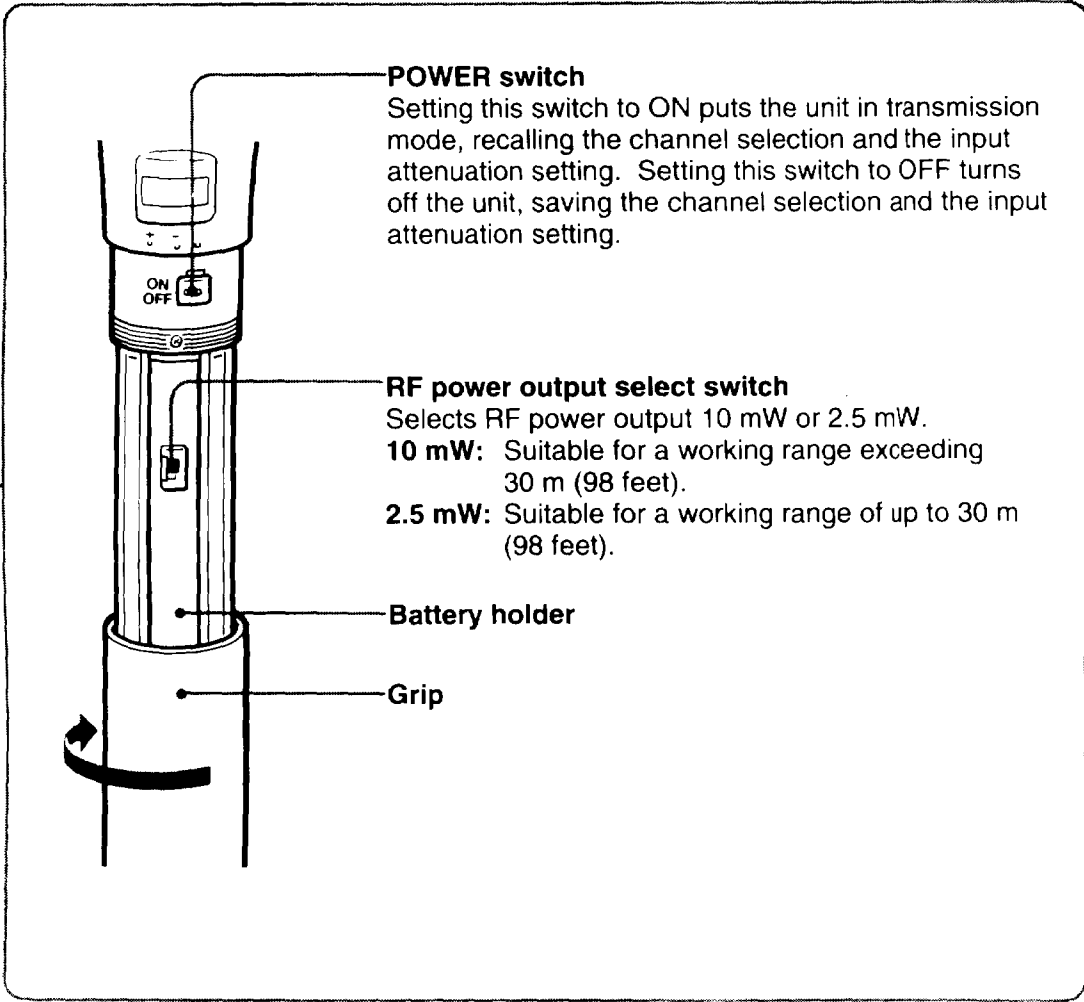
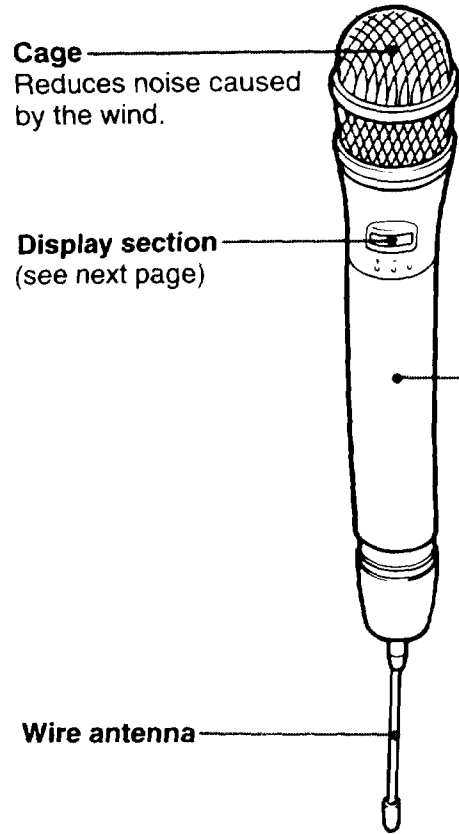

Parts Identification (continued)

AF indicator

The indicator appears when the input audio signal level is higher than needed to obtain the reference deviation.

RF indicator

The indicator appears when the RF carrier is being transmitted.



CH indicator

Indicates the current wireless microphone channel selection in channel display or channel set mode. When the unit is in attenuation display/set mode, this indicator shows "--".

TV/ATT indicator

Indicates the current TV channel selection in channel display or channel set mode, or the current input setting in decibels in attenuation display/set mode.

BATT indicator

- : The batteries are in good condition.
- : The residual battery power is below the 50% level
- : The batteries are exhausted. Replace them. (When this indicator appears, the whole display starts flashing.)

+/- buttons

Use these buttons to increment or decrement the channel selection in channel set mode or input attenuation setting in attenuation display/set mode.

SET button

Use this button to enter channel set or attenuation display/set mode.

+/-/SET buttons

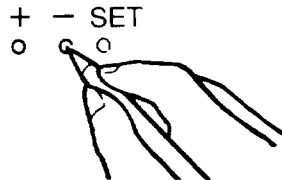

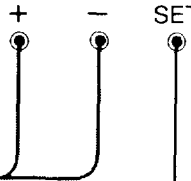
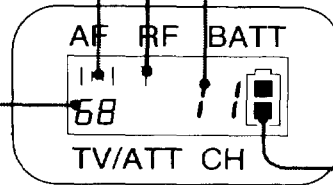

Use a ball-point pen or similar instrument to press these buttons.

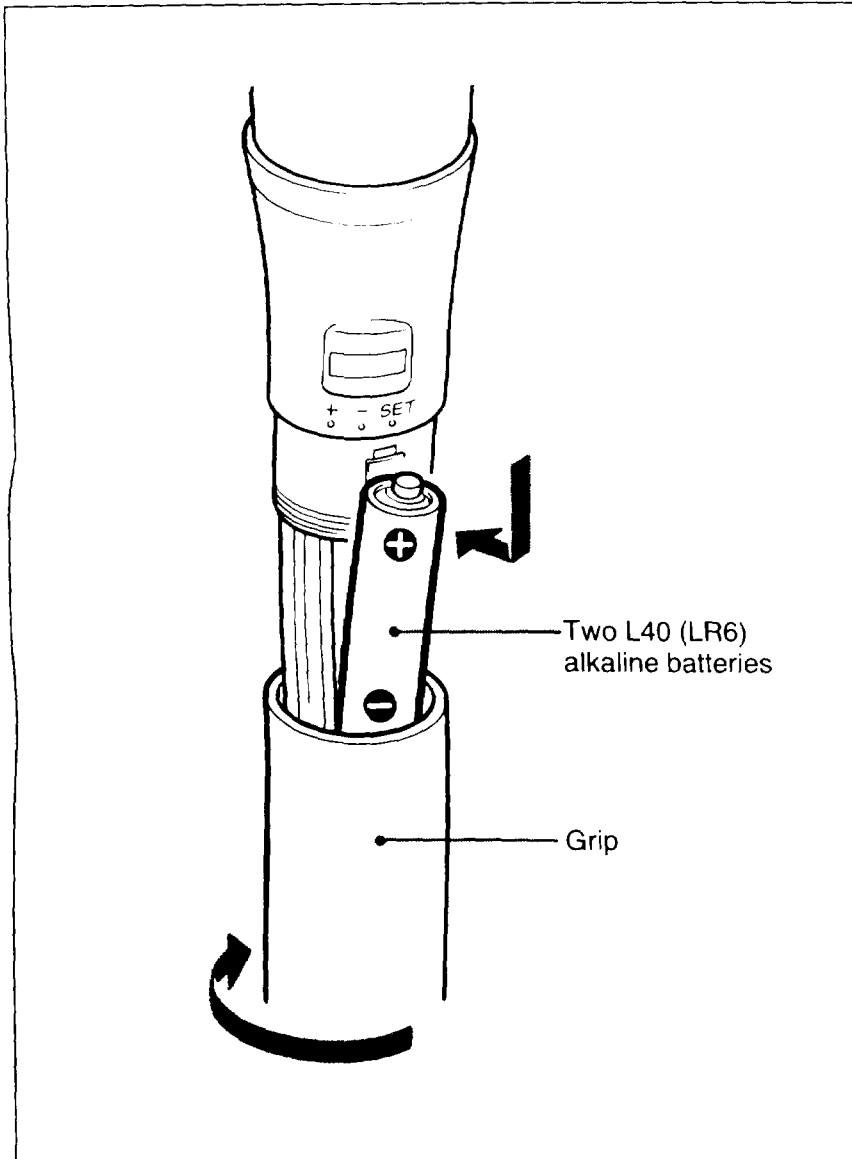

Inserting Batteries



Notes

- Be sure to turn the POWER switch off before replacing the batteries.
- When the unit is turned on with batteries which are exhausted, the BATT indicator displayed may reflect their temporarily recovered power which will reduce very quickly. Before starting extended operation, replace the batteries in the unit even if the BATT indicator shows  or .

Notes on batteries

- Be sure to insert the batteries with the correct polarity.
- Do not pair different types of battery.
- Always replace the two batteries together.
- The batteries are not rechargeable.
- When keeping the unit out of use for extended periods of time, remove the batteries to avoid leakage.
- Should the batteries be found to have leaked in the unit, replace them with new ones after carefully wiping the leakage from the battery holder or case.

Changing the Channel Selection

- 1 While pressing the SET button, set the POWER switch to ON to enter channel set mode.**
The current channel selection will appear on the display.

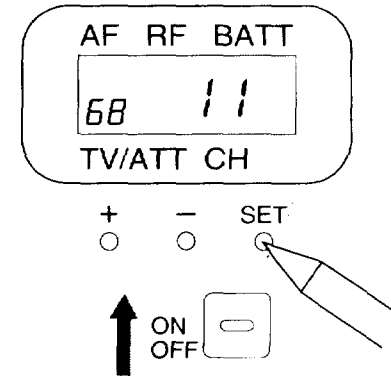

- 2 Press the + button to increment the current channel selection or the - button to decrement it.**
If you keep either button pressed, the channel selection will be incremented or decremented successively.

The setting will cycle the channel number from 68-01 through 69-47.

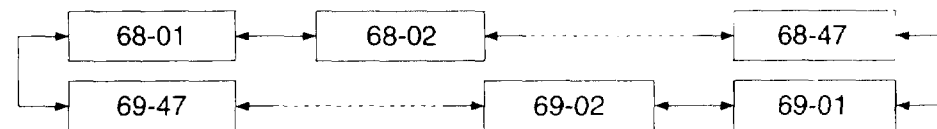
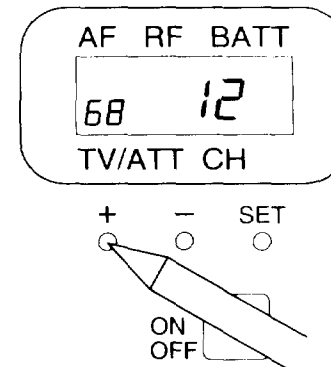

- 3** Set the **POWER** switch to **OFF** to save the selected channel number along with the current input attenuation setting.

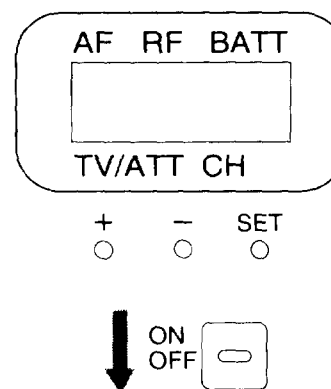

Notes

- The unit cannot transmit in channel set mode.
- Make sure that the channel selected is the same as that selected on the WRR-820A/840A unit used in the same system.
- Depending on the noise or interference conditions, the selectable channels may not necessarily all be usable. If necessary, you can determine the usable channels by stepping the channel selection through a number of channels on the tuner with the microphone/transmitter set to OFF. Those channels on which the RF indicator of the tuner does not light are usable.
- If there is a TV broadcasting station nearby, to avoid possible interference with broadcasting, do not use that station's channel.
- The unit may not operate correctly if it is turned on again immediately after turning off the power while in channel set mode. Pause for a few seconds or more before turning on the power again.

Changing the Input Attenuation Setting

You can change the input attenuation setting in 3-dB steps in the range of 0 to 12 dB.

Raise the setting to decrease the sound volume or lower it to increase the sound volume, using the following procedure:

- 1 When the current channel selection is displayed (that is, when the unit is in either channel set mode or channel display mode), press the SET button to enter attenuation display/set mode.

The current input attenuation setting in decibels will appear on the display.

- Switching from channel set mode to attenuation display/set mode
- Switching from channel display mode to attenuation display/set mode

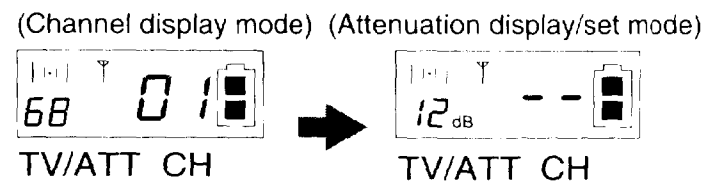
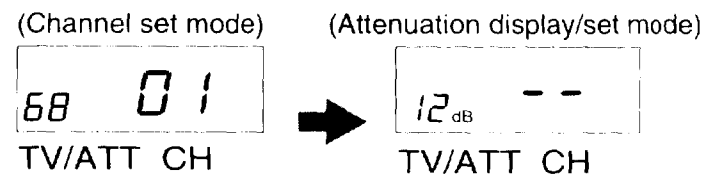
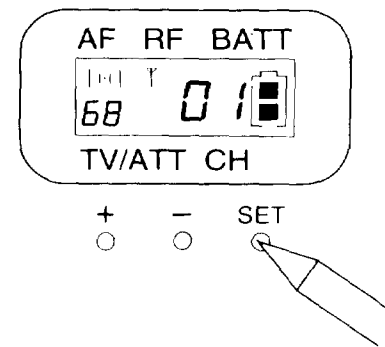

2 Use the + and - buttons to adjust the attenuation setting.

If you keep either button pressed, the input attenuation setting will be incremented or decremented successively until it reaches 0 or 12 dB.

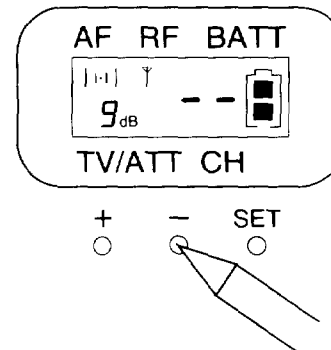

3 Press the SET button to return to the previous mode.

To save the input attenuation setting along with the channel number selected in the preceding channel set mode:

Set the POWER switch to OFF.

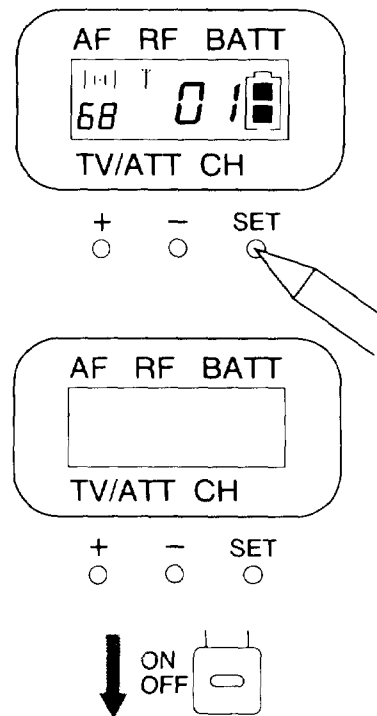

Changing the Input Attenuation Setting (continued)

Notes

- After entering attenuation display/set mode by pressing the SET button in channel set mode, if you do not press any button for about five seconds, the unit will return to channel set mode automatically.
- The attenuation display/set mode entered by pressing the SET button in channel display mode will stay until you press the SET button again. If you turn off the unit without returning to channel display mode, the unit saves the status, so that it will enter attenuation display/set mode when turned on next time.
- Even if you keep on pressing the + or – button, the input attenuation setting does not cycle. After being decremented to 0 dB or incremented to 12 dB, the setting stays unchanged unless you change it in the reverse direction.

Using the Microphone

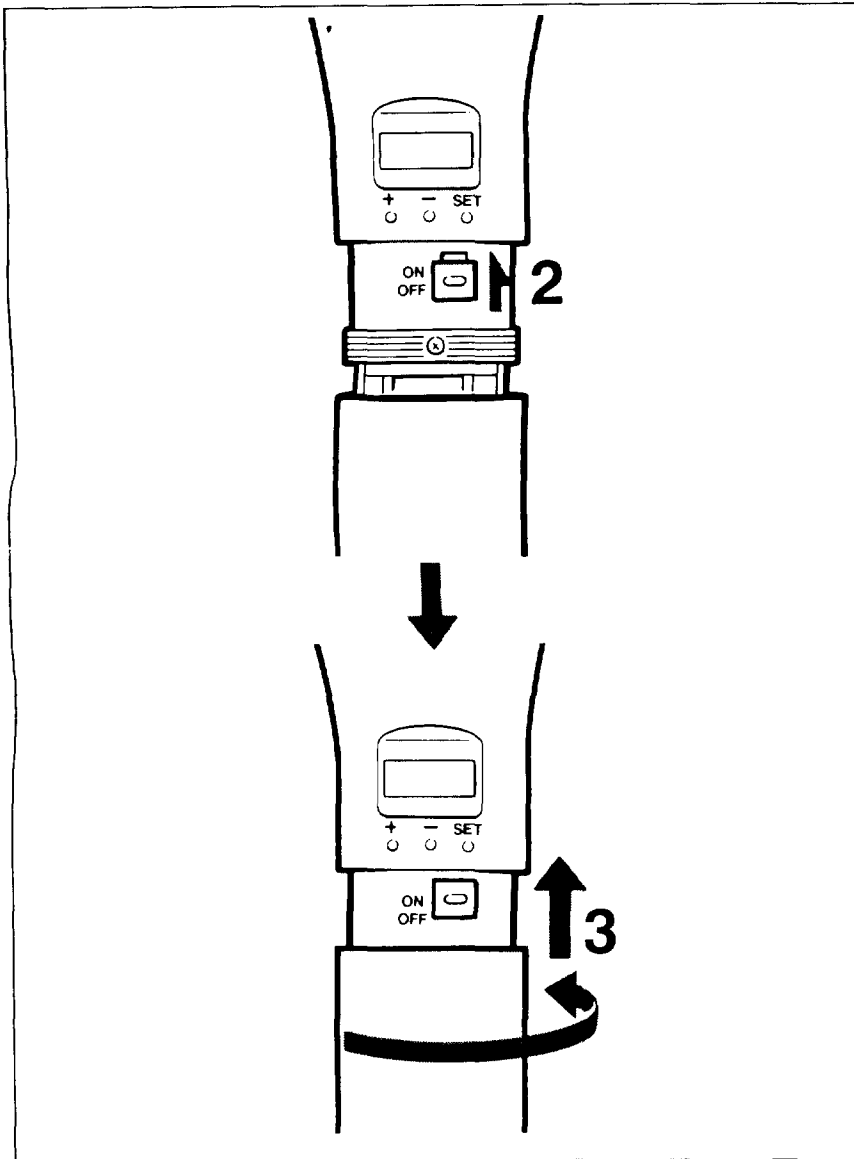

- 1 Select the Channel to be used. (Use the procedure in “Changing the Channel Selection” on pages 10 and 11.)
- 2 Set the POWER switch to ON.
- 3 Fasten the grip.

Notes

- To prevent noise generation, keep the microphones and transmitters at least 3 m (10 feet) away from the antennas when the system is operated using a group which allows selection of up to 11 channels, and at least 6 m (20 feet) away when using a group (with WRT-810A/820A(66)/ (64)) which allows selection of 12 to 19 channels.
- Ensure that the tuners set to channels not being used are either turned off or set to the minimum outlet level (the LEVEL adjustment knob set to MIN).
- Turning the microphone/transmitter on or off may generate some noise. To minimize the impact of such noise, set the LEVEL adjustment knob of the tuner being used to MIN beforehand.
- Switching the unit on without checking the channel selection first may interfere with the operation of other microphones/transmitters, if the current setting is already being used.

Specifications

Transmitter and modulator section

Oscillator	Crystal controlled PLL synthesizer
Carrier frequency	794.125 to 805.875 MHz (94 settings at 125-kHz intervals)
Tone signal	32.768 kHz
Type of emission	110KF3E
RF power output	10 mW/2.5 mW, selectable (50 ohms)
Frequency stability	Within $\pm 0.005\%$
Spurious radiation	Less than 2.5 μ W
Type of antenna	1/4 wavelength wire
Pre-emphasis	50 μ s
Reference deviation	± 5 kHz
Frequency response	70 Hz to 15 kHz
Signal-to-noise ratio	More than 60 dB (A-weighted, with reference deviation at WRR-820A/840A)
Audio attenuator	0 to 12 dB, variable in 3-dB steps
Maximum input sound pressure level	142 dB SPL
Microphone unit	Back electret condenser type

Power section

Power requirements	3 V DC (two L40 (LR6) alkaline batteries)
Battery life	About 8 hours at 25°C or 77°F (with Sony AM3 (LR6) alkaline batteries)
Current consumption	Less than 170 mA (at 3V)

General

Operating temperature	0°C to 50°C (32°F to 122°F)
Storage temperature	-30°C to +60°C (-22°F to +140°F)
Dimensions	48 x 238 mm (maximum dia./length) (1 ¹⁵ / ₁₆ x 9 ³ / ₈ inches)
Weight	About 300 g (including batteries) (10.5 oz)
Supplied accessories	Microphone holder (1) Stand adaptor PF ¹ / ₂ to NS ⁵ / ₈ (1)

Design and specifications are subject to change without notice.

Channels and Carrier Frequencies

Channel	Frequency (MHz) TV-68 Band	Channel	Frequency (MHz) TV-68 Band	Channel	Frequency (MHz) TV-69 Band	Channel	Frequency (MHz) TV-69 Band
68-01	794.125	68-26	797.250	69-01	800.125	69-26	803.250
68-02	794.250	68-27	797.375	69-02	800.250	69-27	803.375
68-03	794.375	68-28	797.500	69-03	800.375	69-28	803.500
68-04	794.500	68-29	797.625	69-04	800.500	69-29	803.625
68-05	794.625	68-30	797.750	69-05	800.625	69-30	803.750
68-06	794.750	68-31	797.875	69-06	800.750	69-31	803.875
68-07	794.875	68-32	798.000	69-07	800.875	69-32	804.000
68-08	795.000	68-33	798.125	69-08	801.000	69-33	804.125
68-09	795.125	68-34	798.250	69-09	801.125	69-34	804.250
68-10	795.250	68-35	798.375	69-10	801.250	69-35	804.375
68-11	795.375	68-36	798.500	69-11	801.375	69-36	804.500
68-12	795.500	68-37	798.625	69-12	801.500	69-37	804.625
68-13	795.625	68-38	798.750	69-13	801.625	69-38	804.750
68-14	795.750	68-39	798.875	69-14	801.750	69-39	804.875
68-15	795.875	68-40	799.000	69-15	801.875	69-40	805.000
68-16	796.000	68-41	799.125	69-16	802.000	69-41	805.125
68-17	796.125	68-42	799.250	69-17	802.125	69-42	805.250
68-18	796.250	68-43	799.375	69-18	802.250	69-43	805.375
68-19	796.375	68-44	799.500	69-19	802.375	69-44	805.500
68-20	796.500	68-45	799.625	69-20	802.500	69-45	805.625
68-21	796.625	68-46	799.750	69-21	802.625	69-46	805.750
68-22	796.750	68-47	799.875	69-22	802.750	69-47	805.875
68-23	796.875			69-23	802.875		
68-24	797.000			69-24	803.000		
68-25	797.125			69-25	803.125		

Block Diagram

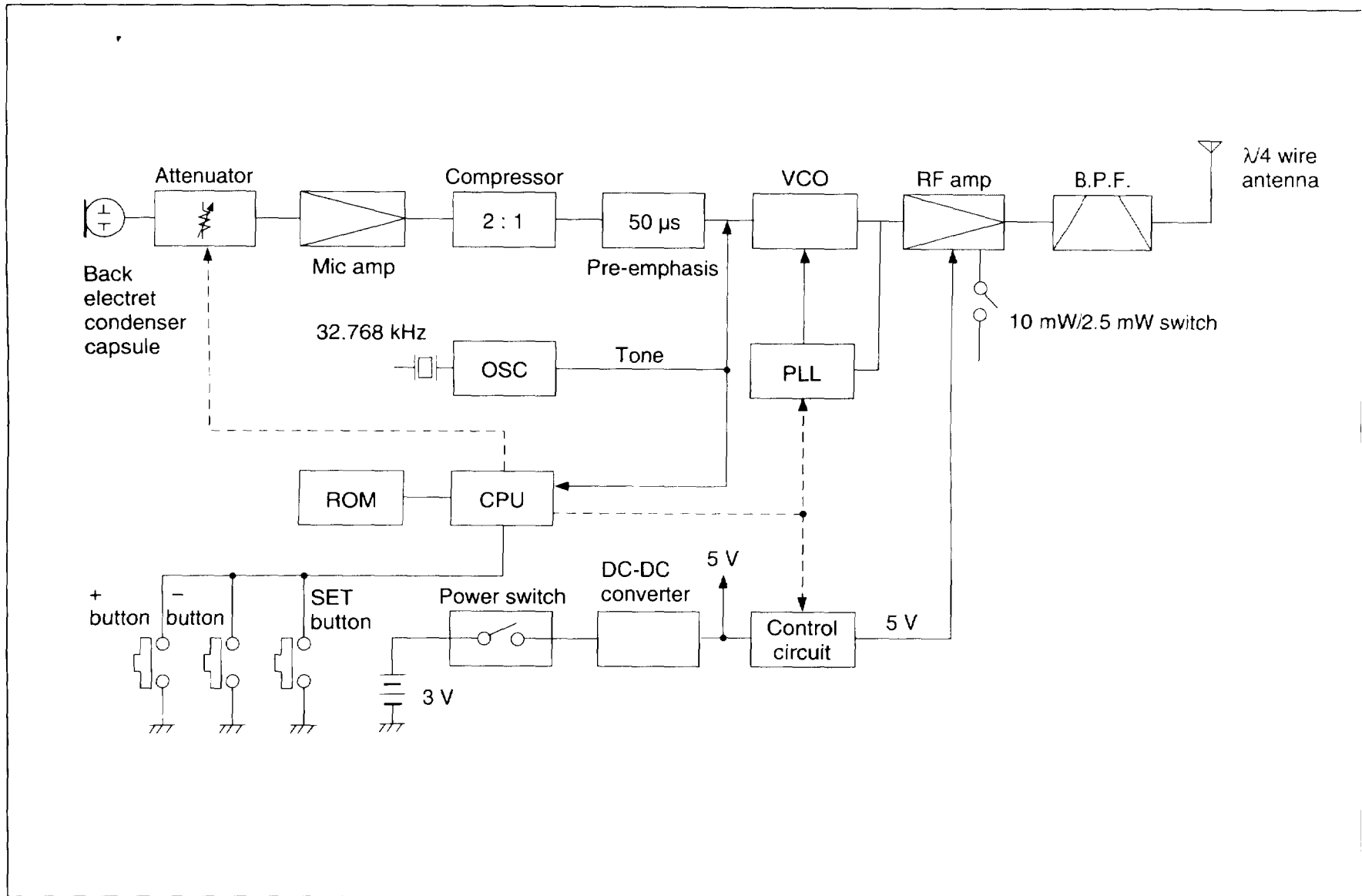

Frequency Response

