

SONY®

ELECTRET CONDENSER
MICROPHONE

ECM-673



OUTLINE

The Sony ECM-673 is a short shotgun, electret condenser-type microphone, which delivers excellent sound performance in field and studio production applications at an affordable price.

Optimized for use with Sony compact camcorders such as the HDV™ Series and DVCAM™ Series, the ECM-673 offers high-sensitivity, low-noise characteristics, and a flat-and-wide frequency response in a compact and lightweight body. In addition, its highly directional response and extreme durability allow clear voice pickup, even in harsh operational environments.

With its high performance, compact design, and high durability, the ECM-673 microphone is an ideal choice for quality-critical sound-acquisition applications.

FEATURES

Superb Sound Quality

The ECM-673 offers an excellent sensitivity of -36 dB (0 dB=1 V/Pa) and a low inherent-noise level of less than 17 dB SPL. This allows the microphone to be used for clear voice pickup, even in noisy environments.

Flat-and-wide Frequency Response

The ECM-673 microphone has a flat-and-wide frequency response (40 Hz to 20 kHz) and delivers extremely smooth and natural sound reproduction.

Compact and Lightweight Design

The ECM-673 has been designed as a highly directional, compact, and lightweight short shotgun microphone. It measures only 200 mm (7 7/8 inches) in length, and weighs just 135 g (4.76 oz), maintaining good balance even when mounted on compact camcorders.

High Durability and Reliability

The vibration-resistant mechanism of the ECM-673 offers high durability and reliability, making it suitable for the harsh environments that can be encountered in field sound-acquisition.

Built-in Low-cut Filter

The built-in two-position (M, V) low-cut switch on the ECM-673 provides a simple method of reducing the effects of unwanted ambient noise.



The ECM-673 attached to a Sony HVR-A1 Series camcorder

SPECIFICATIONS

ECM-673	
Capsule type	Electret condenser
Directivity	Uni-directional (super-cardioid)
Frequency response	40 Hz to 20 kHz
Sensitivity (at 1 kHz)	-36 dB* ¹ ±3 dB
Output impedance (at 1 kHz)	220 Ω ±20%
Dynamic range	107 dB or more
Signal-to-noise ratio	77 dB or more (IEC179 A-weighted, 1 kHz, 1Pa)
Inherent noise	17 dB SPL* ² or less
Wind noise	45 dB SPL* ² or less (with windscreen), 50 dB SPL* ² (without windscreen)
Induction noise from external magnetic field	0 dB SPL* ² or less
Maximum input sound pressure level	124 dB SPL* ²
Power requirements	DC 40 to 52 V
Dimensions	ø20 x 200 mm (ø13/16 x 7 7/8 inches)
Mass	Approx. 135 g (4.76 oz)

*¹ 0 dB=1 V/Pa, at 1 kHz

*² 0 dB=20μ Pa

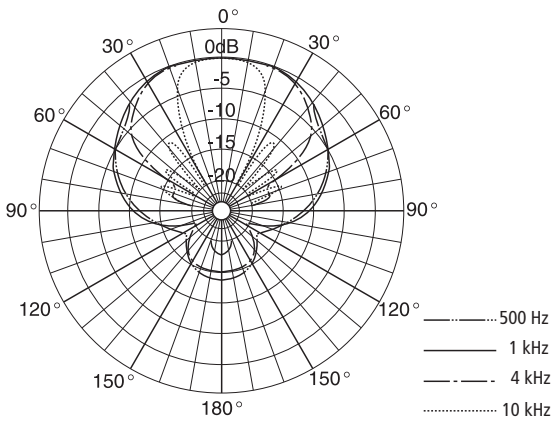

Directivity Characteristics

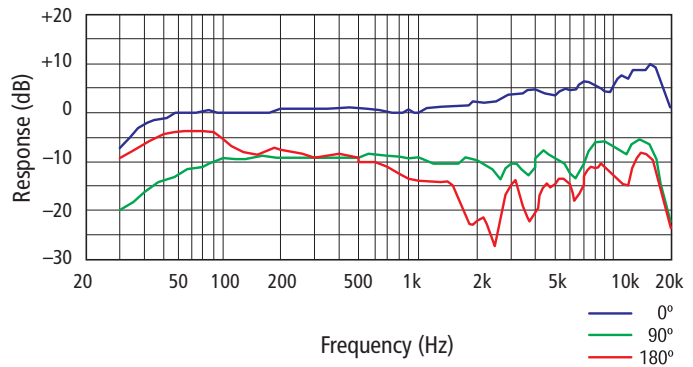

Frequency Response Characteristics

SUPPLIED ACCESSORIES

- Windscreen (x1)
- Microphone holder (x1)
- Microphone spacer (x1)
- Microphone cable (x1)
- Operating instructions (x1)



Distributed by

©2006 Sony Corporation. All rights reserved.
 Reproduction in whole or in part without written permission is prohibited.
 Features and specifications are subject to change without notice.
 All non-metric weights and measurements are approximate.
 Sony and DVCAM are trademarks of Sony Corporation.
 HDV and HDV logo are trademarks of Sony Corporation and Victor Company of Japan, Limited (JVC).