

## UHF Synthesized Wireless Microphone System



# Superb Performance and Reliability in an Affordable Package



Since its introduction, the unique qualities of the Sony UHF synthesized wireless microphone system have been proven in many different applications. It has been particularly successful in critical applications such as broadcasting and production, where its low noise, wide audio dynamic range, stable RF transmission and reception, and high reliability have been vital factors.

In recent years, Sony has enhanced its wireless microphone line-up to fulfill the ever-increasing needs for wireless operations. Offering a broad range of choices, this family presents a solution to virtually any wireless microphone application from the very simple to the most sophisticated. Such applications include ENG and EFP location, conference and entertainment, TV studio production, theater, and live performance to name just a few. A variety of options are also made available so that systems are established to suit different operational needs.

The Sony UHF synthesized wireless microphone system offers a perfect choice for all levels of operational and budgetary needs.

## Contents

<b>Sony Wireless Microphone Common Features</b> ————— 3	<b>Tuners</b> ————— 10	<b>Optional Accessories</b> ————— 14	<b>Powered Mixer</b> ————— 16
<b>System Examples</b> ————— 4	<ul style="list-style-type: none"> <li>• WRR-862A/862B</li> <li>• WRR-855A/855B</li> <li>• WRR-861A/861B</li> <li>• MB-8N</li> <li>• WRU-8N</li> <li>• MB-806A</li> <li>• MB-X6</li> <li>• WRU-806A/806B</li> </ul>	<ul style="list-style-type: none"> <li>• ECM-88 Series</li> <li>• ECM-77 Series</li> <li>• ECM-66BC</li> <li>• ECM-44 Series</li> <li>• ECM-166BC</li> <li>• ECM-310BC</li> <li>• ECM-322BC</li> <li>• CA-WR855</li> <li>• A-8278-057-A</li> <li>• EC-1.5CF</li> </ul>	<ul style="list-style-type: none"> <li>• SRP-X700P</li> </ul>
<b>Transmitters</b> ————— 6	<b>Distributors and Antenna</b> ————— 13		<b>Frequency Lists</b> ————— 17
<ul style="list-style-type: none"> <li>• WRT-847A/847B</li> <li>• WRT-867A</li> <li>• WRT-807A/807B</li> <li>• WRT-8P</li> <li>• WRT-8B</li> <li>• WRT-822A/822B</li> </ul>	<ul style="list-style-type: none"> <li>• WD-850</li> <li>• WD-880A</li> <li>• AN-820A</li> </ul>		<b>Feature Comparisons</b> ————— 19
			<b>Specifications</b> ————— 21
			<b>Appendix</b> ————— 24
			<ul style="list-style-type: none"> <li>• Multi-channel Simultaneous Operations</li> <li>• Tuner and Camcorder Combinations</li> </ul>

### PLL Synthesized System

Phase Locked Loop (PLL) frequency synthesized systems are employed both in transmitters and receivers, assuring carrier stability and providing easy access to multiple frequencies. These PLL controlled systems provide highly stable, selectable frequencies to be generated in increments of 125 kHz. Users may choose from 94\* frequencies on A-series (USA type) models and from 188 frequencies on B-series (USA type) models.

\*In the case of AU models, users may choose from 102 frequencies.

### Space Diversity Reception System

A space diversity reception system is used to eliminate signal dropout. Dual antenna inputs and reception circuits incorporated in the diversity system receive signals over two different paths and select the stronger signal as the output. This switching operation is undetectable on the audio output of the receivers.

### Pre-programmed Frequency Groups

Optimum combinations of calculated and practically tested intermodulation-free frequencies are stored in each receiver to make it easy to choose the correct frequencies for simultaneous multi-channel operation. These frequencies are arranged in groups, with each group pre-programmed to allow interference free operation.

### Advanced Filtering

The Sony wireless units all employ Helical, Ceramic and/or SAW (Surface Acoustic Wave) filters as appropriate. This offers stable reception and superb audio quality, and also enables the unique miniaturization seen in most of the Sony products.

### Tone Squelch Circuitry

The wireless microphone transmitters also transmit a 32.768 kHz pilot-tone signal along with the audio signal. In the receivers, a squelch circuit is present, and the audio signal is only output when the tone signal has been correctly received.

This squelch function is designed to virtually prevent the output of unwanted signals or noise from other signal transmissions in the air, as well as the RF noise and popping noise that occur when the transmitter is power on or off.

### Compander System for Wide Dynamic Range and Low Noise

A compander (compressor/expander) system is included for improved audio dynamic range and low noise and interference. The time constants for attack and release times are carefully chosen in the various transmitters to match the application, ensuring minimized noise level while providing smooth and superior audio quality.

### Multiple Information on Easy-to-read LCD and LED

Most receivers and transmitters feature easy-to-read LCD panel and LED indicators, which provide extensive information on the operating conditions.

Most receivers will display the RF-input level, audio-output status, current channel number and frequency, and battery status of the transmitter.

Most transmitters do in essence have the same information available in the receivers such as audio-input and RF-output status, current channel number and frequency, input attenuation setting, and accumulated battery operating time.

### Remote Battery Alarm on Receiver

For added assurance of continued operation, you can monitor the battery reserves of handheld, body pack and plug-on transmitters. Remaining battery life is indicated on both the transmitter and receiver, with additional indication approximate one hour\* before the battery goes dead. On the receiver, the battery indicator on the LCD and LED displays also flash, helping to avoid the chance of battery failure at a critical moment.

\*This may vary depending on the operational environment.

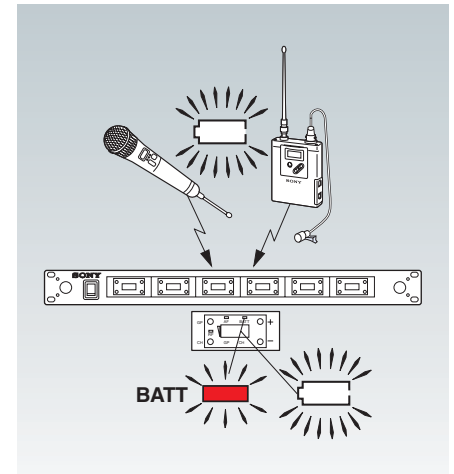

### Consistent RF Power Output

A DC-DC convert circuit built into the power supply section of microphones/transmitters assures consistent output power over the life of the batteries.

### Channel Setting Back Up

Each unit has a convenient memory back up for storing operating frequencies. When the power switch is turned on, the previous channel setting is automatically recalled and displayed.

## Live Music/Theater Productions

### ◆ 6-channel Simultaneous Operation

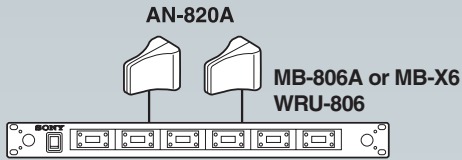

#### Required components

- MB-806A or MB-X6 Tuner base unit x 1
- WRU-806 Tuner unit x 6
- AN-820A Antenna x 2
- Transmitter x 6

### ◆ 16-channel Simultaneous Operation

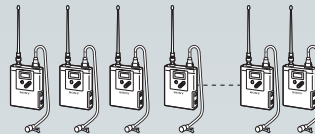
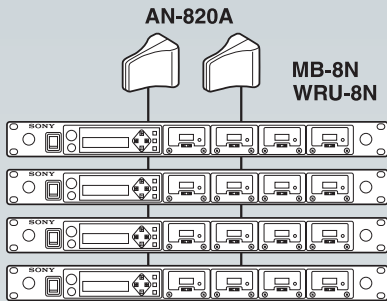

#### Required components

- MB-8N Tuner base unit x 4
- WRU-8N Tuner unit x 16
- AN-820A Antenna x 2
- Transmitter\* x 16

\* Lavalier microphones are not supplied with transmitters.

### ◆ 54-channel Simultaneous Operation

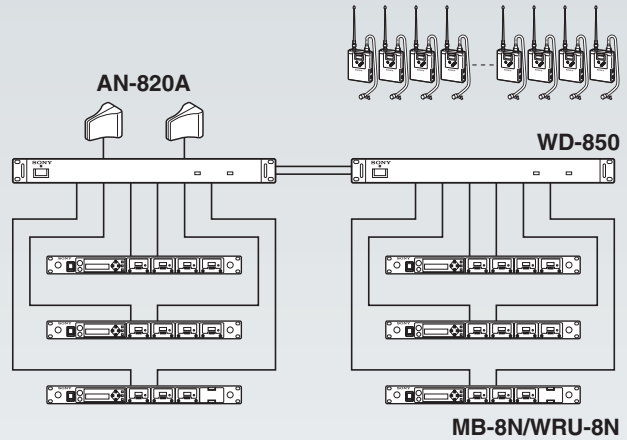
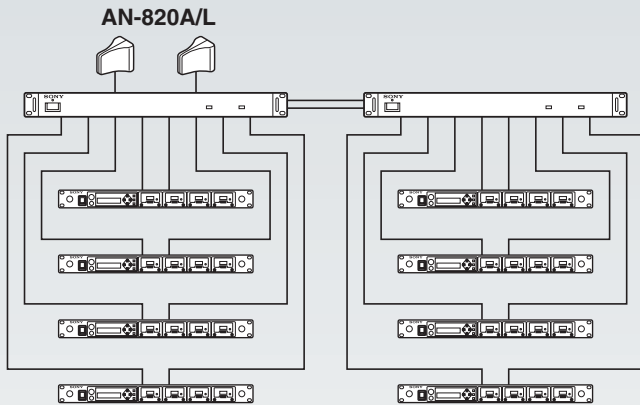

#### Required components

- MB-8N Tuner base unit x 14
- WRU-8N Tuner unit x 54
- WD-850 x 4
- AN-820A/L x 2
- AN-820A x 2
- Transmitter x 54

\* Lavalier microphones are not supplied with transmitters.

Note: The above system can be configured when using USA-type models.  
When using AU-type models, max. 20-channel simultaneous operation is possible.

## Conference/Educational Applications

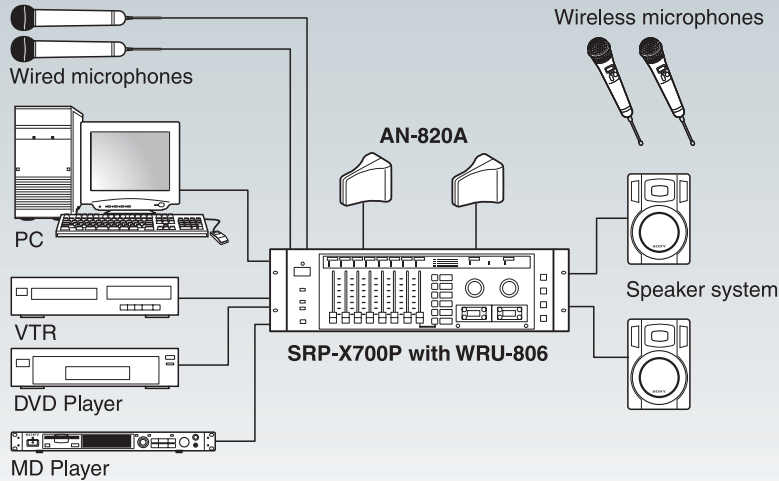

### Required components

- WRU-806 Tuner unit x 2
- Wireless Microphone x 2
- Wired Microphone x 2
- AN-820A Antenna x 2
- SRP-X700P Audio Mixer x 1

## ENG/EFP Applications

### ◆ HDCAM™/Digital Betacam™/XDCAM™ MPEG IMX™ Camcorder with WRR-855

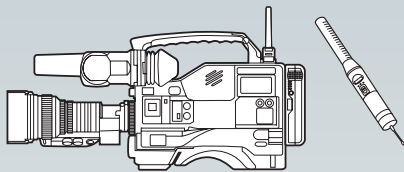

#### Required components

- WRR-855 Portable tuner x 1 (slot-in configuration)
- Transmitter x 1

### ◆ DVCAM™/XDCAM HD Camcorder with WRR-855

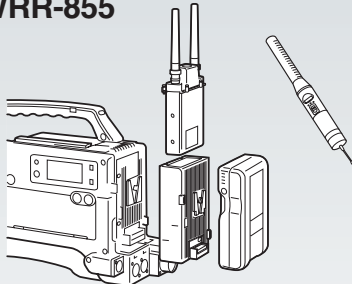

#### Required components

- WRR-855 Portable tuner x 1
- CA-WR855 Camera adaptor x 1
- Transmitter x 1

### ◆ HDCAM/Digital Betacam/XDCAM/MPEG IMX Camcorder with WRR-862

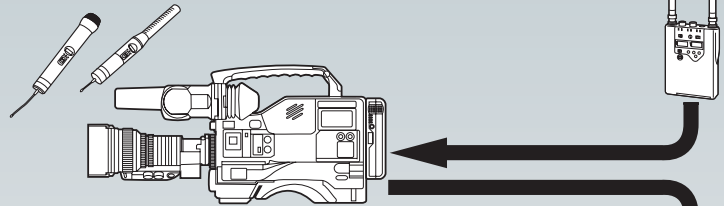

#### Required components

- WRR-862 Portable tuner x 1
- A-8278-057-A Mounting bracket x 1
- Transmitter x 2

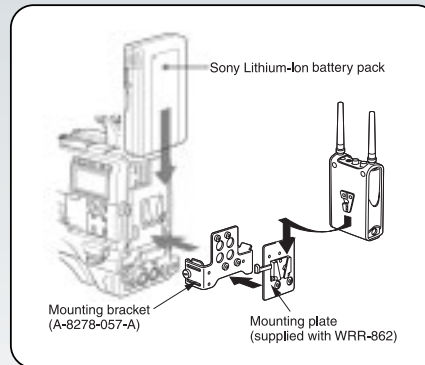

## WRT-847A/847B UHF Synthesized Transmitter Unit

U30/32 U42/44 U62/64 U66/68 AU66



- Five optional microphone capsules are available, providing a choice of characteristics that suit a range of different applications. Microphone capsules are available individually. (One head is required for the WRT-847A/847B to function.)
- Audio compander time constant is switchable to suit different capsules
- Selectable RF output level: 10 mW for simultaneous multi-channel operation and 50 mW for long distance operation
- Audio gain and attenuation setting from +9 dB to -12 dB in 3 dB steps
- Lockable external power switch (ON/OFF)
- Two AA-size (LR6) alkaline batteries provide approximately eight hours of continuous operation

## CU-F780 Capsule Unit



- Dynamic microphone capsule with super cardioid polar pattern
- Uses the same high quality edgewise winding CCAW voice coil that is employed in the acclaimed Sony F-780 wired microphone
- Designed for vocal applications including live music performance
- Frequency response: 50 Hz to 18 kHz
- Dimensions:  $\varnothing$  51 x 90 mm  
( $\varnothing$  2 1/8 x 3 5/8 inches)
- Mass: 180 g (6.3 oz)

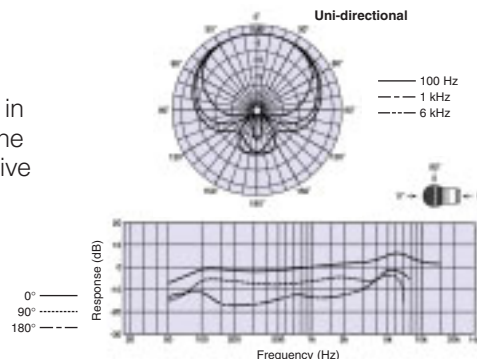

## CU-G780 Capsule Unit



- Dynamic microphone capsule with super cardioid polar pattern
- Special design, based on the capsule of F-780 microphone, to cope with high sound pressure level vocals and incorporating outstanding feedback rejection
- Designed for vocal use
- Frequency response: 50 Hz to 20 kHz
- Dimensions:  $\varnothing$  51 x 90 mm  
( $\varnothing$  2 1/8 x 3 5/8 inches)
- Mass: 180 g (6.3 oz)

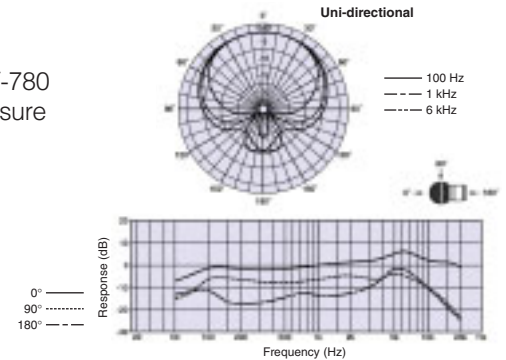

## CU-E700 Capsule Unit



- Electret condenser microphone capsule with super cardioid polar pattern
- Smooth frequency response for natural sound reproduction
- Suitable for critical vocal and speech applications
- Frequency response: 50 Hz to 18 kHz
- Max. SPL: 150 dB
- Dimensions:  $\varnothing$  51 x 98 mm  
( $\varnothing$  2 1/8 x 3 7/8 inches)
- Mass: 170 g (6.0 oz)

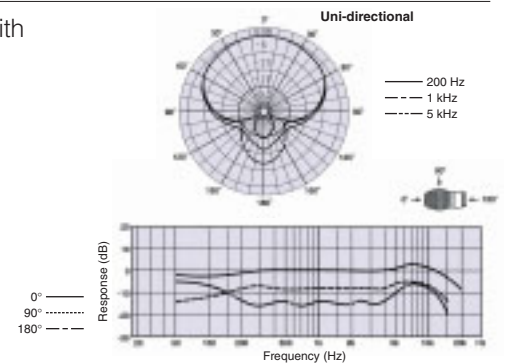

## CU-E672 Capsule Unit



- Electret condenser microphone capsule with hyper cardioid polar pattern
- A wide variety of applications in news-gathering, sports events and interviews
- The supplied windscreen reduces wind noise and popping
- Frequency response: 50 Hz to 16 kHz
- Max. SPL: 120 dB
- Dimensions:  $\varnothing$  37 x 172 mm  
( $\varnothing$  1 1/2 x 6 7/8 inches)
- Mass: 150 g (5.3 oz)
- Supplied accessory: Urethane windscreen (1)

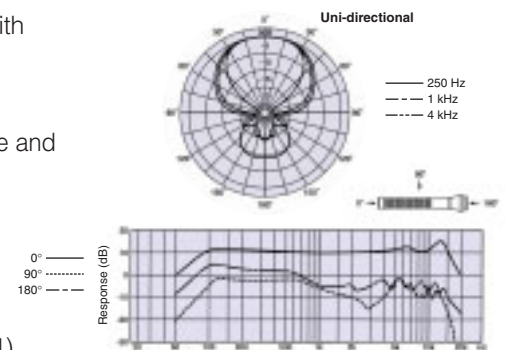

## CU-F117 Capsule Unit



- Dynamic microphone capsule with omni-directional polar pattern
- Superb rejection of wind noise and popping
- Designed for interview applications
- Frequency response: 50 Hz to 15 kHz
- Dimensions:  $\varnothing$  44 x 105 mm  
( $\varnothing$  1 3/4 x 4 1/4 inches)
- Mass: 170 g (6.0 oz)
- Supplied accessory: Urethane windscreen (1)

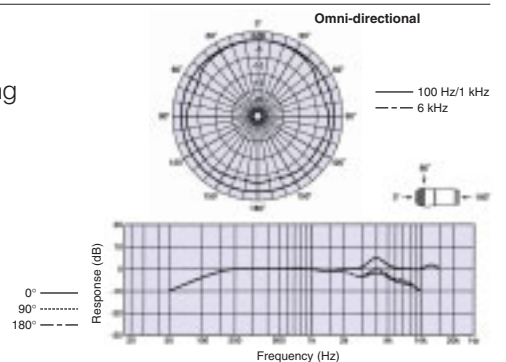

## WRT-867A UHF Synthesized Wireless Microphone U68 AU66



- Dynamic microphone capsule with supercardioid polar pattern
- Resilient body structure for extremely high quality sound
- Incorporates a high quality, edgewise-winding voice coil with lightweight CCAW (Copper Clad Aluminum Wire) and AlNiCo magnet, which provides powerful, crisp and clear sound as well as presence in the middle and high frequency range
- Ideal for critical vocal applications for broadcast program and film production
- Channel select switches, audio attenuator switch and an LCD indicator inside the body to help prevent accidental operation

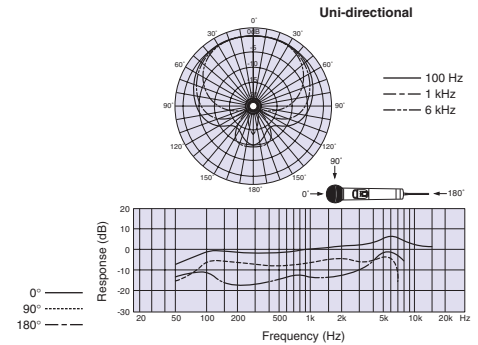

## WRT-807A/807B UHF Synthesized Wireless Microphone U30/32 U42/44 U62/64 U66/68 AU66



- Uses the same dynamic microphone capsule that is employed in the F-780 professional wired microphone
- High quality sound for vocals – powerful, crisp and clear
- Single AA-size (LR6) alkaline battery provides continuous operation for approximately five hours
- Lockable external power switch (ON/OFF)

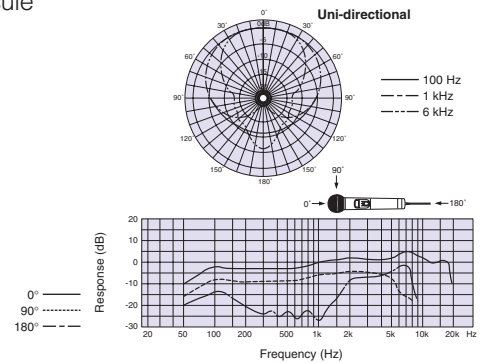

## WRT-8P UHF Synthesized Transmitter U30/32 U42/44 U62/64 U66/68



- Converts a wired microphone to a wireless microphone via an XLR-type connector
- Compact and lightweight metal body provides high durability and good balance with compatible microphones
- 250 mW high RF output power for stable long-distance transmission
- Selectable RF output power: 250 mW/50 mW
- +48 V power supply capability
- Switchable input level: MIC/LINE
- Attenuator function allows adjustment of the audio-input level
- A backlit LCD provides extensive information
- Optimized balance when combined with the F-112 dynamic microphone



---

## WRT-8B UHF Synthesized Transmitter

U30/32 U42/44 U62/64 U66/68 AU66



- Ultra compact and lightweight: 140 g including batteries
- Selectable RF power output: 50 mW output for long-distance transmission or 10 mW output for multi-channel simultaneous operation
- Switchable input level (Line or MIC level) and attenuator level control knob
- SMA-J type, removable antenna
- Approximately 13 hours of continuous operation with two AA-size alkaline (LR6) batteries at 10 mW output
- Accepts the output of professional lavalier microphones equipped with a Sony 4-pin connector (SMC9-4P)

---

## WRT-822A/822B UHF Synthesized Transmitter

U30/32 U42/44 U62/64 U66/68 AU66



- Approximately six\* hours of continuous operation with two AA-size (LR6) alkaline batteries
- Compact, lightweight, magnesium alloy body
- 20\*\* mW RF power output
- Accepts the output of professional lavalier microphones equipped with a Sony 4-pin connector (SMC9-4P)

\* In the case of the WRT-822B (USA type).  
The WRT-822A (AU type) offers approximately eight hours of continuous operation.

\*\* In the case of the WRT-822B (USA type).  
The WRT-822A (AU type) offers 10 mW power output.



### WRR-862A/862B UHF Synthesized Dual Diversity Tuner **U30/32 U42/44 U62/64 U66/68 AU66**

- Receives two independent RF signals simultaneously on two separate channels
- Compact and lightweight: 400 g (14.1 oz) including batteries
- Two way powering: Internal battery operation or operation on external power from Sony camcorders via the supplied cable
- A red LED starts flashing approximately one\* hour before the transmitter's battery is exhausted
- Two SMC9-4S (Sony 4-pin) audio output connectors are provided on the top panel
- Switchable RF squelch levels: ON (5 dB $\mu$ , 10 dB $\mu$ , 15 dB $\mu$ ) or OFF
- Stereo mini jack for monitoring the output sound (switchable: Tuner 1/Tuner 2/Mixed) with headphones
- Monitor volume control provided

\*This time may vary depending on the operational environment.



### WRR-855A/855B UHF Synthesized Diversity Tuner **U30/32 U42/44 U62/64 U66/68 AU66**

- Space Diversity Tuner for camcorder use
- Easily mounts onto Sony HDCAM/Digital Betacam/XDCAM/MPEG IMX camcorders without need for audio/power cables or a mounting adaptor
- Compact and lightweight design: 280 g (11 oz)
- A D-sub 15-pin connector for audio output to a Sony professional camcorder and for receiving its power supply from the camcorder



### WRR-861A/861B UHF Synthesized Diversity Tuner **U30/32 U42/44 U62/64 U66/68 AU66**

- Single-channel version of the WRR-862A/862B
- Two way powering: Internal battery operation or operation on external power from Sony camcorders via the supplied cable
- A red LED starts flashing approximately one\* hour before the transmitter's battery is exhausted
- Switchable RF squelch levels: ON (5 dB $\mu$ , 10 dB $\mu$ , 15 dB $\mu$ ) or OFF
- Stereo mini jack for monitoring the output sound
- Monitor volume control provided

\*This time may vary depending on the operational environment.

## MB-8N Tuner Base Unit U AU



MB-8N with four WRU-8N tuner units installed.



- Accommodates up to four WRU-8N tuner modules in a 1U high, rack-mountable chassis
- Built-in antenna-divider allows four MB-8Ns to be daisy-chained for up to 16-channel simultaneous operation without the need of an external divider. Addition of the WD-880A allows multi-channel operation with even more channels added.
- Control settings such as audio output levels, RF squelch levels, attenuator levels for the installed tuner modules, and power supply setting (ON/OFF) for the connected AN-820A antennas are available from the front panel
- An auto channel assignment function for extra receiver modules with self-detection and skipping of unusable channels
- A headphone monitor jack and level control knob are located on the front panel. The monitor output can be selected from individual WRU-8N tuner modules or mixed sound from all installed modules
- Computer-based remote control is also possible via a standard Ethernet (10BASE-T) connection. The supplied software allows full monitoring of the operating status and all control settings available on both the MB-8N and WRU-8N. Multi-channel settings can be stored as files

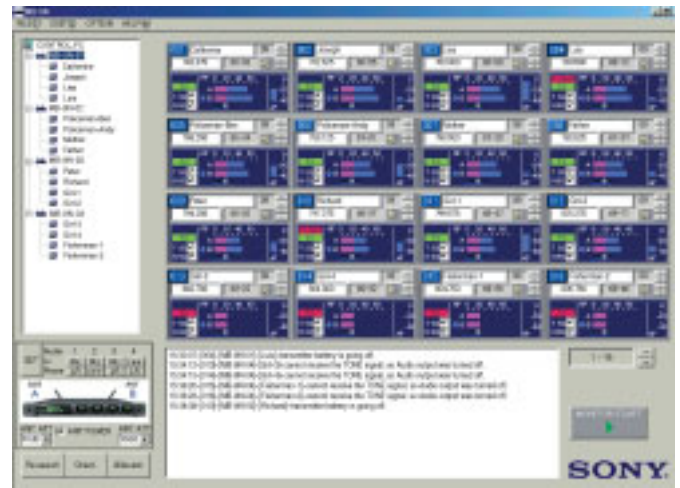

MB-8N supplied software GUI

## WRU-8N UHF Synthesized Tuner Unit U30/32 U42/44 U62/64 U66/68 AU66



- Plug-in diversity tuner module for the MB-8N tuner base unit
- A jog dial allows operators to quickly choose the desired channel setting
- Pre-programmed groups for interference-free, multi-channel operation
- A red LED starts flashing approximately one\* hour before the transmitter's battery is exhausted
- Precise RF squelch level setting: 10 dB $\mu$ , 20 dB $\mu$ , 30 dB $\mu$  or OFF
- Space diversity reception for dependable RF reception

\*This time may vary depending on the operational environment.

## MB-806A Tuner Base Unit U AU



MB-806A with six WRU-806A/806B tuner units installed.



- Accommodates up to six WRU-806A/806B for up to six channels of simultaneous operation
- Addition of the WD-850 or WD-880A allows multi-channel operation with even more channels
- RF input attenuator switch (10 dB/0 dB)
- Balanced XLR output connector for each tuner and mix output
- Selectable output level: -58 dBm (for MIC) or -20 dBm (for LINE) at  $\pm 5$  kHz deviation at 1 kHz modulation
- Auto channel assignment function for extra receiver modules with self-detection and skipping of unusable channels
- Supplied passive antennas for rear mounting (with provision for front mounting)
- Modular design, 1U high 19-inch rack unit

## MB-X6 Tuner Base Unit U AU



MB-X6 with six WRU-806A/806B tuner units installed.



- Accommodates up to six WRU-806A/806B for up to six channels of simultaneous operation
- Addition of the WD-850 or WD-880A allows multi-channel operation with even more channels
- Easy mechanism for attaching and detaching tuner modules
- RF input attenuator switch (10 dB/0 dB)
- Balanced XLR output connector for each tuner and mix output
- Selectable output level: -58 dBu (for MIC) or -20 dBu (for LINE) at  $\pm 5$  kHz deviation at 1 kHz modulation
- Auto channel search function automatically selects unoccupied channels
- Supplied with passive antennas
- Modular, 1U high, 19-inch rack unit

## WRU-806A/806B UHF Synthesized Tuner Unit U30/32 U42/44 U62/64 U66/68 AU66



- Plug-in diversity receiver module for MB-806A/X6 tuner base unit
- Pre-programmed groups for interference free, multi-channel operation
- RF input status, audio output status, and battery alarm indications by both LED and LCD to double check operating condition
- Space diversity reception for dependable RF reception

## WD-850 UHF Antenna Divider U AU



Front panel



Rear panel

- Provides diversity output for up to four receivers/tuner base units
- Multi-channel operation by combination with the MB-8N and WRU-8N or the MB-806A/X6 and WRU-806A/806B
- Cascade output can be used for an additional antenna divider or receiver/tuner base unit
- Two pair of antenna input connectors for up to four AN-820A antennas to expand the operating area of a wireless microphone system

## WD-880A UHF Antenna Divider U AU



WD-880A (USA type) front panel



WD-880A (USA type) rear panel



WD-880A (AU type) front panel



WD-880A (AU type) rear panel

- Ideal for complex, multi-channel applications from large scale live music events to TV OBs and large theater productions
  - Stable reception minimizing interference and distortion
  - Band pass SAW filters divide the spectrum of TV channels into multiple frequency bands, which are output from the WD-880A
  - Dual inputs and outputs for diversity operation
  - Switchable power supply (DC 9 V or 12 V) for the AN-820A UHF antennas
  - LED indicators to show the output connection status
  - 1U size rack mountable
- \* The USA type operates in 770 MHz to 806 MHz.  
The AU type operates in 792 MHz to 806 MHz.

## AN-820A UHF Antenna



- Built-in RF amplifier (10 dB gain)
- Easy installation on a wall or on a microphone stand with the supplied stand adaptor
- Used in pairs for diversity reception
- LED indication for installation check
- External power supply provided from the MB-8N/806A/X6 or the WD-850/880A via a coaxial cable

## Optional Accessories



### ECM-88 Series Lavalier Microphone

- Ultra-miniature, omni-directional microphone
- Rectangular dual-diaphragm mechanism contributes to a significant reduction in handling noise
- Water-resistant design
- Flat-and-wide frequency response: 20 Hz to 20 kHz

- Sensitivity: -52 dB  $\pm$ 2 dB (in combination with optional DC-78) -39 dB (12.6 mW)
- Signal-to-noise ratio: 68 dB or more (A-weighted, 1 kHz, 1 Pa)
- Inherent noise: 26 dB SPL or less (A-weighted, 1 kHz, 1 Pa)
- Microphone head: 3.5 mm (5/32 inch) x 3.5 mm (5/32 inch) x 16.8 mm (11/16 inch), approx. 0.6 g (0.02 oz)
- Cable length: ECM-88BC: 1.2 m (3.9 feet), ECM-88BPT/88FPT: 2.5 m (8.2 feet)
- Three types available:
  - ECM-88BC:** Black-colored model supplied with a Sony 4-pin connector (SMC9-4P), for use with the WRT-8B/822A/822B
  - ECM-88BPT:** Black-colored model supplied without a connector (pigtail), enabling users to choose connectors according to their transmitter
  - ECM-88FPT:** Beige-colored model supplied without a connector (pigtail)



### ECM-77 Series Lavalier Microphone

- High performance, miniature microphone
- Omni-directional, electret condenser microphone
- Frequency response: 40 Hz to 20 kHz
- Sensitivity: -39.0 dB (11.2 mV) (0 dB = 1V/Pa, at 1 kHz)
- Microphone head: 5.6 mm (1/4 inch) dia. x 12.5 mm (1/2 inches), approx. 1.5 g (0.05 oz)
- Cable length: ECM-77BC: 1.2 m (3.9 feet), ECM-77BPT: 3.0 m (9.8 feet)
- Two types available:
  - ECM-77BC:** Black-colored model supplied with a Sony 4-pin connector (SMC9-4P), for use with the WRT-8B/822A/822B
  - ECM-77BPT:** Black-colored model supplied without a connector (pigtail), enabling users to choose connectors according to their transmitter



### ECM-66BC Lavalier Microphone

- Uni-directional, electret condenser microphone
- Resistant to howling by rejecting indirect sound
- Wide dynamic range (101 dB), and high maximum input-sound-pressure level (130 dB SPL)
- Frequency: 70 Hz to 14 kHz
- Sensitivity: -36.5 dB (15 mV) (0 dB=1 V/Pa, at 1 kHz)
- Low inherent-noise characteristics
- Microphone head: 10.6 mm (7/16 inch) dia. x 24.2 mm (31/32 inch), approx. 7 g (0.25 oz)
- Cable length: 1.2 m (3.9 feet)
- Black-colored model supplied with a Sony 4-pin connector (SMC9-4P), for use with the WRT-8B/822A/822B



### ECM-44 Series Lavalier Microphone

- Omni-directional, electret condenser microphone
- Superior sound quality
- Frequency response: 40 Hz to 15 kHz
- Sensitivity: -40 dB SPL (10 mV) (0 dB = 1V/Pa, at 1 kHz)
- Microphone head: 8.5 mm (11/32 inch) dia. x 14.5 mm (19/32 inches), approx. 2 g (0.07 oz)
- Cable length: ECM-44BC: 1.2 m (3.9 feet), ECM-44BPT: 3.0 m (9.8 feet)
- Two types available:
  - ECM-44BC:** Black-colored model supplied with a Sony 4-pin connector (SMC9-4P), for use with the WRT-8B/822A/822B
  - ECM-44BPT:** Black-colored model supplied without a connector (pigtail)



### ECM-166BC Lavalier Microphone

- Uni-directional, electret condenser microphone
- Resistant to howling by rejecting indirect sound
- Ideal for institutional uses and sound contracting applications such as speeches, lectures and conferences
- Frequency response: 100 Hz to 10 kHz
- Sensitivity: -45 dB (5.6 mV) (0 dB = 1V/Pa, at 1 kHz)
- Microphone head: 12.5 mm (1/2 inch) dia. x 23.5 mm (15/16 inches), approx. 3.5 g (0.12 oz)
- Cable length: 1.2 m (3.9 feet)
- Supplied with the Sony 4-pin (SMC9-4P) connector for use with the WRT-8B/822A/822B



### **ECM-310BC** Headset Microphone

- Lightweight, headset-style microphone for sound reinforcement applications
- Wide-cardioid, electret condenser microphone provides crisp and clear sound while isolating desired sound from surrounding ambience
- Adjustable hinge and goose-neck
- Frequency response: 70 Hz to 12 kHz
- Sensitivity: -44 dB (6.3 mV)  $\pm$ 3 dB (0 dB = 1V/Pa, at 1 kHz)
- Cable length: 1.2 m (3.9 feet)
- Supplied with the Sony 4-pin (SMC9-4P) connector for use with the WRT-8B/822A/822B



### **ECM-322BC** Earset Microphone

- Earset microphone for multimedia presentation applications
- Omni-directional microphone capsule for clear voice pickup from any direction
- Extra light weight of only 15 g (0.5 oz) excluding the cable
- Adjustable microphone position
- Secure and comfortable fit
- Frequency response: 70 Hz to 15 kHz
- Sensitivity: -43 dB (7.1 mV)  $\pm$ 3 dB (0 dB = 1V/Pa, at 1 kHz)
- Cable length: 1.4 m (4.5 feet)
- Equipped with the Sony 4-pin (SMC9-4P) connector for use with the WRT-8B/822A/822B



### **CA-WR855** Camera Adaptor

- Enables a WRR-855A/855B portable tuner to be mounted on Sony DSR-450WS/450WSP/400/400P DVCAM camcorders and PDW-F350/F330 XDCAM HD camcorders with direct audio/power connection interfaces

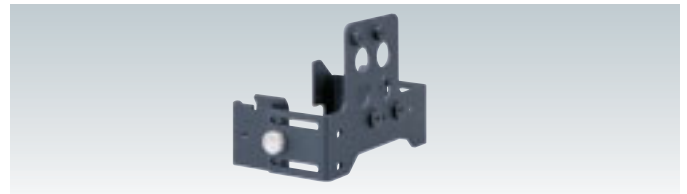

### **A-8278-057-A** Mounting Bracket

- For mounting any Sony portable tuner (with tuner supplied hardware) to Sony professional camcorders which operate on Sony Lithium-Ion battery packs



### **EC-1.5CF** Microphone Cable

- Fitted with an XLR-3-11 connector and SMC9-4P connector
- Allows a microphone with a 3-pin male XLR output connector to be connected to WRT-8B/822A/822B bodypack transmitter
- Cable length: 1.5 m (4.9 feet)

## SRP-X700P Powered Mixer



SRP-X700P with two optional WRU-806A/806B installed



- All-in-one presentation mixer ideal for conference rooms, lecture halls, theaters and other presentation applications
- Contains a high-quality digital audio mixer, power amplifier, wireless tuner slots (for optional tuner modules), RGB/video switcher, feedback reducer and equalizer in a compact 3U high unit
- Combines a six-input RGB/video switcher with an audio mixer. The switcher allows a variety of video and PC graphic sources to be routed to the presentation system while the audio mixer processes input signals from wired and wireless microphones as well as audio playback devices.
- Processes and mixes the 6-mono inputs (4 mic, 2 mic/line), one-stereo input, and the stereo or 5.1 inputs selected by the switcher to 10 outputs
- Wireless microphone slots accommodates up to two WRU-806A/806B or UWP-X1/X2 tuner modules
- Programmable TRIM, LCF, parametric EQ, feedback reducer, compressor/limiter, Delay, and automatic microphone mixing with 20-scene memory capacity
- Integrated machine control capability:
  - Remote control of SRP-X700P via USB, RS-232C from a PC
  - RS-232C output port allows remote control of a projector/plasma display unit from the SRP-X700P to select the projector's input from RGB, component or composite as well as control of power on/standby
  - Control-S ports allows remote control of Sony's VTRs, DVD/CD/MD players and video/data projectors from the SRP-X700P
  - Parallel output port allows remote control of peripheral equipment such as a curtain, screen and/or lights from the SRP-X700P\*
- Supplied software for comprehensive set-up and controls of SRP-X700P from a PC via USB

\* Requires an interface box between the SRP-X700P and external device.



# Frequency Lists

## A64 (USA type)

64-01	770.125	65-01	776.125
64-02	770.250	65-02	776.250
64-03	770.375	65-03	776.375
64-04	770.500	65-04	776.500
64-05	770.625	65-05	776.625
64-06	770.750	65-06	776.750
64-07	770.875	65-07	776.875
64-08	771.000	65-08	777.000
64-09	771.125	65-09	777.125
64-10	771.250	65-10	777.250
64-11	771.375	65-11	777.375
64-12	771.500	65-12	777.500
64-13	771.625	65-13	777.625
64-14	771.750	65-14	777.750
64-15	771.875	65-15	777.875
64-16	772.000	65-16	778.000
64-17	772.125	65-17	778.125
64-18	772.250	65-18	778.250
64-19	772.375	65-19	778.375
64-20	772.500	65-20	778.500
64-21	772.625	65-21	778.625
64-22	772.750	65-22	778.750
64-23	772.875	65-23	778.875
64-24	773.000	65-24	779.000
64-25	773.125	65-25	779.125
64-26	773.250	65-26	779.250
64-27	773.375	65-27	779.375
64-28	773.500	65-28	779.500
64-29	773.625	65-29	779.625
64-30	773.750	65-30	779.750
64-31	773.875	65-31	779.875
64-32	774.000	65-32	780.000
64-33	774.125	65-33	780.125
64-34	774.250	65-34	780.250
64-35	774.375	65-35	780.375
64-36	774.500	65-36	780.500
64-37	774.625	65-37	780.625
64-38	774.750	65-38	780.750
64-39	774.875	65-39	780.875
64-40	775.000	65-40	781.000
64-41	775.125	65-41	781.125
64-42	775.250	65-42	781.250
64-43	775.375	65-43	781.375
64-44	775.500	65-44	781.500
64-45	775.625	65-45	781.625
64-46	775.750	65-46	781.750
64-47	775.875	65-47	781.875

## A66 (USA type)

66-01	782.125	67-01	788.125
66-02	782.250	67-02	788.250
66-03	782.375	67-03	788.375
66-04	782.500	67-04	788.500
66-05	782.625	67-05	788.625
66-06	782.750	67-06	788.750
66-07	782.875	67-07	788.875
66-08	783.000	67-08	789.000
66-09	783.125	67-09	789.125
66-10	783.250	67-10	789.250
66-11	783.375	67-11	789.375
66-12	783.500	67-12	789.500
66-13	783.625	67-13	789.625
66-14	783.750	67-14	789.750
66-15	783.875	67-15	789.875
66-16	784.000	67-16	790.000
66-17	784.125	67-17	790.125
66-18	784.250	67-18	790.250
66-19	784.375	67-19	790.375
66-20	784.500	67-20	790.500
66-21	784.625	67-21	790.625
66-22	784.750	67-22	790.750
66-23	784.875	67-23	790.875
66-24	785.000	67-24	791.000
66-25	785.125	67-25	791.125
66-26	785.250	67-26	791.250
66-27	785.375	67-27	791.375
66-28	785.500	67-28	791.500
66-29	785.625	67-29	791.625
66-30	785.750	67-30	791.750
66-31	785.875	67-31	791.875
66-32	786.000	67-32	792.000
66-33	786.125	67-33	792.125
66-34	786.250	67-34	792.250
66-35	786.375	67-35	792.375
66-36	786.500	67-36	792.500
66-37	786.625	67-37	792.625
66-38	786.750	67-38	792.750
66-39	786.875	67-39	792.875
66-40	787.000	67-40	793.000
66-41	787.125	67-41	793.125
66-42	787.250	67-42	793.250
66-43	787.375	67-43	793.375
66-44	787.500	67-44	793.500
66-45	787.625	67-45	793.625
66-46	787.750	67-46	793.750
66-47	787.875	67-47	793.875

## A68 (USA type)

68-01	794.125	69-01	800.125
68-02	794.250	69-02	800.250
68-03	794.375	69-03	800.375
68-04	794.500	69-04	800.500
68-05	794.625	69-05	800.625
68-06	794.750	69-06	800.750
68-07	794.875	69-07	800.875
68-08	795.000	69-08	801.000
68-09	795.125	69-09	801.125
68-10	795.250	69-10	801.250
68-11	795.375	69-11	801.375
68-12	795.500	69-12	801.500
68-13	795.625	69-13	801.625
68-14	795.750	69-14	801.750
68-15	795.875	69-15	801.875
68-16	796.000	69-16	802.000
68-17	796.125	69-17	802.125
68-18	796.250	69-18	802.250
68-19	796.375	69-19	802.375
68-20	796.500	69-20	802.500
68-21	796.625	69-21	802.625
68-22	796.750	69-22	802.750
68-23	796.875	69-23	802.875
68-24	797.000	69-24	803.000
68-25	797.125	69-25	803.125
68-26	797.250	69-26	803.250
68-27	797.375	69-27	803.375
68-28	797.500	69-28	803.500
68-29	797.625	69-29	803.625
68-30	797.750	69-30	803.750
68-31	797.875	69-31	803.875
68-32	798.000	69-32	804.000
68-33	798.125	69-33	804.125
68-34	798.250	69-34	804.250
68-35	798.375	69-35	804.375
68-36	798.500	69-36	804.500
68-37	798.625	69-37	804.625
68-38	798.750	69-38	804.750
68-39	798.875	69-39	804.875
68-40	799.000	69-40	805.000
68-41	799.125	69-41	805.125
68-42	799.250	69-42	805.250
68-43	799.375	69-43	805.375
68-44	799.500	69-44	805.500
68-45	799.625	69-45	805.625
68-46	799.750	69-46	805.750
68-47	799.875	69-47	805.875

## AU66 (AU type)

66-01	792.250	67-01	799.250
66-02	792.375	67-02	799.375
66-03	792.500	67-03	799.500
66-04	792.625	67-04	799.625
66-05	792.750	67-05	799.750
66-06	792.875	67-06	799.875
66-07	793.000	67-07	800.000
66-08	793.125	67-08	800.125
66-09	793.250	67-09	800.250
66-10	793.375	67-10	800.375
66-11	793.500	67-11	800.500
66-12	793.625	67-12	800.625
66-13	793.750	67-13	800.750
66-14	793.875	67-14	800.875
66-15	794.000	67-15	801.000
66-16	794.125	67-16	801.125
66-17	794.250	67-17	801.250
66-18	794.375	67-18	801.375
66-19	794.500	67-19	801.500
66-20	794.625	67-20	801.625
66-21	794.750	67-21	801.750
66-22	794.875	67-22	801.875
66-23	795.000	67-23	802.000
66-24	795.125	67-24	802.125
66-25	795.250	67-25	802.250
66-26	795.375	67-26	802.375
66-27	795.500	67-27	802.500
66-28	795.625	67-28	802.625
66-29	795.750	67-29	802.750
66-30	795.875	67-30	802.875
66-31	796.000	67-31	803.000
66-32	796.125	67-32	803.125
66-33	796.250	67-33	803.250
66-34	796.375	67-34	803.375
66-35	796.500	67-35	803.500
66-36	796.625	67-36	803.625
66-37	796.750	67-37	803.750
66-38	796.875	67-38	803.875
66-39	797.000	67-39	804.000
66-40	797.125	67-40	804.125
66-41	797.250	67-41	804.250
66-42	797.375	67-42	804.375
66-43	797.500	67-43	804.500
66-44	797.625	67-44	804.625
66-45	797.750	67-45	804.750
66-46	797.875	67-46	804.875
66-47	798.000	67-47	805.000
66-48	798.125	67-48	805.125
66-49	798.250	67-49	805.250
66-50	798.375	67-50	805.375
66-51	798.500	67-51	805.500



## Feature Comparisons

### Handheld Microphones

	WRT-847A WRT-847B	WRT-867A	WRT-807A WRT-807B
UHF, PLL Synthesized System	●	●	●
Operating Frequency Band	24 MHz band (WRT-847B, USA type) 14 MHz band (WRT-847A, AU type)	12 MHz band (USA type) 14 MHz band (AU type)	24 MHz band (WRT-807B, USA type) 14 MHz band (WRT-807A, AU type)
Tone Signal	●	●	●
Compander System (compressor)	●	●	●
Microphone Capsule	Dynamic, uni-directional (with optional CU-F780/G780) Dynamic, omni-directional (with optional CU-F117) Electret condenser, uni-directional (with optional CU-E700/E672)	Dynamic, uni-directional	Dynamic, uni-directional
Audio-attenuator Levels	-12 dB to +9 dB (in 3 dB steps)	0 dB, 6 dB or 12 dB	0 dB to 21 dB (in 3 dB steps)
Antenna	1/4 wavelength whip antenna	Helical antenna	1/4 wavelength whip antenna
RF Power Output	50 mW or 10 mW	10 mW	10 mW
LCD Panel	Channel number, Frequency in MHz, Audio input status, RF-output level setting (Low or High), RF output status, Compander time constant, Attenuator level, Battery reserve, Accumulated operating time	Channel number	Channel number, Frequency in MHz, Audio input status, RF output status, Attenuator level, Battery reserve, Accumulated operating time
LED Indicators	—	Power-on status	—
Transmission of Battery Status	●	—	●
Battery Life	Approx. 8 hours	Approx. 5 hours	Approx. 5 hours
Channel Setting Back-up	●	●	●
Supplied accessories	Microphone holder (1), Stand adaptor (1), Channel color seal (1), Soft case (1), Operating instructions (1)	Microphone holder (1), Stand adaptor (1), Channel color seal (1), Operating instructions (1)	Microphone holder (1), Metal-screw stand adaptor (1), Operating instructions (1)

### Bodypack/Plug-on Transmitters

	WRT-8B	WRT-822A WRT-822B	WRT-8P
UHF, PLL Synthesized System	●	●	●
Operating frequency band	24 MHz band (USA type) 14 MHz band (AU type)	24 MHz band (WRT-822B, USA type) 14 MHz band (WRT-822A, AU type)	24 MHz band (USA type)
Tone Signal	●	●	●
Compander System (Compressor)	●	●	●
Audio-attenuator Levels	0 dB to 40 dB, continuous	0 dB to 21 dB (in 3 dB steps)	0 dB to 20 dB, continuous
Antenna	1/4 wavelength whip antenna (removable)	1/4 wavelength whip antenna	Integrated type
RF Power Output	50 mW or 10 mW	10 mW with WRT-822A 20 mW with WRT-822B	250 mW or 50 mW
LCD Panel	Channel number, Frequency in MHz, Audio input status, RF output level setting (Low or High), RF output status, Battery reserve, Accumulated operating time	Channel number, Frequency in MHz, Audio input status, RF output status, Attenuator level, Battery reserve, Accumulated operating time	Channel number, Frequency in MHz, Audio input status, Audio input status (MIC/LINE), RF output level setting (Low or High), RF output status, Battery reserve, +48 V power status
LED Indicators	Audio input level (peak level)	—	Audio input level(reference level or peak level) +48 V power supply
Transmission of Battery Status	●	●	●
Audio Input Connectors	Sony 4-pin (SMC9-4S)	Sony 4-pin (SMC9-4S)	XLR type 3-pin
Battery Life*	Approx. 13 hours at 10 mW output Approx. 6 hours at 50 mW output	Approx. 8 hours with WRT-822A Approx. 6 hours with WRT-822B	Approx. 2.5 hours at 250 mW output Approx. 4 hours at 50 mW output
Channel Setting Back-up	●	●	●
Supplied accessories	Soft case (1), Spare battery case (1), Microphone cable (SMC9-4P to XLR 3-pin) (1), Operating instructions (1)	Leatherette case (1), Operating instructions (1)	Soft case (1), Operating instructions (1)

\*When not supplying power to the microphone

# Feature Comparisons

## Portable Tuners

	WRR-862A WRR-862B	WRR-855A WRR-855B	WRR-861A WRR-861B
UHF, PLL Synthesized System	●	●	●
Operating Frequency Band	24 MHz band (WRR-862B, USA type) 14 MHz band (WRR-862A, AU type)	24 MHz band (WRR-855B, USA type) 14 MHz band (WRR-855A, AU type)	24 MHz band (WRR-861B, USA type) 14 MHz band (WRR-861A, AU type)
Space Diversity Reception System	●	●	●
Pre-programmed Frequency Groups	●	●	●
Advanced Filtering (SAW filters)	●	●	●
Tone Squelch Circuitry	●	●	●
Compander System (expander)	●	●	●
RF Squelch Levels	5 dB $\mu$ , 10 dB $\mu$ , 15 dB $\mu$ or OFF	10 dB $\mu$ or OFF	5 dB $\mu$ , 10 dB $\mu$ , 15 dB $\mu$ or OFF
LCD Panel	Channel number, Frequency in MHz, RF input level, Audio output status, Tuner battery reserve, Accumulated operating time	Channel number	Channel number, Frequency in MHz, RF input level, Audio output status, Tuner battery reserve, Accumulated operating time
LED Indicators	RF input level, Diversity reception status, Transmitter battery alarm	RF input level, Audio output status	RF input level, Diversity reception status, Transmitter battery alarm
Remote Battery Alarm of Transmitters	●	—	●
Audio Output Connectors	Sony 4-pin (SMC9-4S)	D-sub 15-pin	Sony 4-pin (SMC9-4S)
Battery Life	Approx. 5 hours	—*	Approx. 8 hours
Channel Setting Back-up	●	●	●
Supplied accessories	Attachment case (1), Mounting plate for use with optional A-8278-057-A Mounting bracket (1), Antennas (1 pair), Output cable (SMC9-4S to XLR 3-pin) (2), DC cable (1), Operating instructions (1)	Antennas (1 pair), Operating instructions (1)	Attachment case (1), Mounting plate for use with optional A-8278-057-A Mounting bracket (1), Antennas (1 pair), Output cable (SMC9-4S to XLR 3-pin) (1) DC cable (1), Operating instructions (1)

\*The WRR-855A/855B receive power from a camcorder via the D-sub 15-pin connector.

## Tuners

	MB-8N with WRU-8N	MB-806A/X6 with WRU-806A/WRU-806B
UHF, PLL Synthesized System	●	●
Operating Frequency Band	24 MHz band (USA type) 14 MHz band (AU type)	24 MHz band (WRU-806B, USA type) 14 MHz band (WRU-806A, AU type)
Space Diversity Reception System	●	●
Pre-programmed Frequency Groups	●	●
Advanced Filtering (SAW filters)	●	●
Tone Squelch Circuitry	●	●
Compander System (expander)	●	●
RF Squelch Levels	10 dB $\mu$ , 20 dB $\mu$ , 30 dB $\mu$ or OFF	30 dB $\mu$
LCD Panel	<b>MB-8N:</b> Menus for parameter setup <b>WRU-8N:</b> Channel number, Frequency in MHz, RF input level, Audio output status,	<b>WRU-806A/806B:</b> Channel number, Frequency in MHz, RF input level, Audio output status, Transmitter battery reserve
LED Indicators	<b>WRU-8N:</b> Diversity reception status, Audio output status, Transmitter battery alarm	<b>WRU-806A/806B:</b> RF input status, Audio output status, Transmitter battery alarm
Remote Battery Alarm of Transmitters	●	●
Audio Output Connectors	XLR 3-pin type (main) and D-sub 15-pin, female (sub)	XLR 3-pin type
Computer-based Control	●	—
Channel Setting Back-up	●	●
Supplied accessories	<b>MB-8N:</b> AC power cord (1), CD-ROM containing operating instructions and MB-8N supplied software (1) <b>WRU-8N:</b> —	<b>MB-806A/X6:</b> AC power cord (1) Antennas (1 pair) Operating instructions (1) <b>WRU-806A/806B:</b> —

## Handheld Microphones

	WRT-847A/847B	WRT-867A	WRT-807A/807B
Carrier frequency range:	566 MHz to 590 MHz (U30/32) 638 MHz to 662 MHz (U42/44) 758 MHz to 782 MHz (U62/64) 782 MHz to 806 MHz (U66/68) 792 MHz to 806 MHz (AU66)	794 MHz to 806 MHz (U68) 792 MHz to 806 MHz (AU66)	566 MHz to 590 MHz (U30/32) 638 MHz to 662 MHz (U42/44) 758 MHz to 782 MHz (U62/64) 782 MHz to 806 MHz (U66/68) 792 MHz to 806 MHz (AU66)
Oscillator:	Crystal controlled PLL synthesizer	Crystal controlled PLL synthesizer	Crystal controlled PLL synthesizer
Type of emission:	F3E	F3E	F3E
RF power output:	10 mW/50 mW selectable (50 Ω load)	10 mW (50 Ω load)	10 mW (50 Ω load)
Antenna:	1/4 wave length wire antenna	Helical antenna	1/4 wave length wire antenna
Reference deviation:	±5 kHz (94 dB SPL, 1 kHz)	±5 kHz (94 dB SPL, 1 kHz)	±5 kHz (94 dB SPL, 1 kHz)
Frequency response:	50 Hz to 18 kHz (typical)	40 Hz to 20 kHz (typical)	50 Hz to 15 kHz (typical)
Signal-to-noise ratio:	60 dB or more (A-weighted, at reference deviation)	60 dB or more (A-weighted, at reference deviation)	60 dB or more (A-weighted, at reference deviation)
Audio attenuator adjustment range (pad):	-12 dB to +9 dB variable in 3 dB steps	0, 6 dB or 12 dB switchable	0 to 21 dB, variable in 3 dB steps
Max. input sound pressure level:	142 dB SPL (with CU-F780/G780/E700/F117 at audio gain -12 dB) 120 dB SPL (with CU-E672)	142 dB SPL (with 12 dB attenuator)	151 dB SPL (with 21 dB attenuator)
Microphone capsule:	Interchangeable (Optional)	Dynamic	Dynamic
Directivity:	—	Uni-directional	Uni-directional
Operating voltage:	DC 3.0 V (two LR6 AA-size alkaline batteries)	DC 1.5 V (one LR6 AA-size alkaline battery)	DC 1.5 V (one LR6 AA-size alkaline battery)
Battery life (at 25 °C (77 °F), with Sony LR6 AA-size alkaline batteries) :	Approx. 8 hours	Approx. 4 hours	Approx. 5 hours
Dimensions:	ø 37 x 150 mm (ø 1 1/2 x 6 inches)	ø 51 x 195 mm (ø 2 1/8 x 7 3/4 inches)	ø 51 x 238 mm (ø 2 1/8 x 9 3/8 inches)
Mass:	Approx. 190 g (6.7 oz) including batteries	Approx. 325 g (11.5 oz) including battery	Approx. 440 g (15.5 oz) including battery
Supplied accessories:	Microphone holder (1), Stand adaptor (1), Channel color seal (1), Softcase (1), Operating instructions (1)	Microphone holder (1), Stand adaptor (1), Channel color seal (1), Operating instructions (1)	Microphone holder (1), Metal-screw stand adaptor (1), Operating instructions (1)

## Bodypack/Plug-on Transmitters

	WRT-8B	WRT-822A/822B	WRT-8P
Carrier frequency range:	566 MHz to 590 MHz (U30/32) 638 MHz to 662 MHz (U42/44) 758 MHz to 782 MHz (U62/64) 782 MHz to 806 MHz (U66/68) 792 MHz to 806 MHz (AU66)	566 MHz to 590 MHz (U30/32) 638 MHz to 662 MHz (U42/44) 758 MHz to 782 MHz (U62/64) 782 MHz to 806 MHz (U66/68) 792 MHz to 806 MHz (AU66)	566 MHz to 590 MHz (U30/32) 638 MHz to 662 MHz (U42/44) 758 MHz to 782 MHz (U62/64) 782 MHz to 806 MHz (U66/68)
Oscillator:	Crystal controlled PLL synthesizer	Crystal controlled PLL synthesizer	Crystal controlled PLL synthesizer
Type of emission:	F3E	F3E	F3E
RF power output:	10 mW or 50 mW (e.r.p.) selectable	10 mW (AU-type) (50 Ω load) 20 mW (USA-type) (50 Ω load)	250 mW or 50 mW selectable
Antenna:	1/4 wave length wire antenna (SMA-J type connector)	1/4 wave length wire antenna	Integrated type
Reference deviation:	±5 kHz (-60 dBV, 1 kHz input, MIC position) ±5 kHz (-20 dBu, 1 kHz input, LINE position)	±5 kHz (-60 dBV, 1 kHz input)	±10 kHz (-60 dBV, 1 kHz input, MIC position) ±10 kHz (-18 dBu, 1 kHz input, LINE position)
Frequency response:	40 Hz to 20 kHz (typical)	70 Hz to 15 kHz (typical)	50 Hz to 18 kHz (typical)
Signal-to-noise ratio:	60 dB or more (A-weighted, at reference deviation)	60 dB (A-weighted, at reference deviation)	60 dB or more (A-weighted, at reference deviation)
Audio attenuator adjustment range (pad):	0 to 40 dB, continuous	0 to 21 dB, variable in 3 dB step	0 dB to 20 dB, continuous
Max. input level:	-2 dBV (1 kHz input, MIC position) +38 dBu (1 kHz input, LINE position)	-3 dBV (with 21 dB attenuator)	-20 dBV (1 kHz input, MIC position, ATT=0 dB) +22 dBu (1 kHz input, LINE position, ATT=0 dB)
Input connectors:	Sony 4-pin (SMC9-4S) (1)	Sony 4-pin (SMC9-4S) (1)	XLR type 3-pin, female
Operating voltage:	DC 3.0 V (two LR6 AA-size alkaline batteries)	DC 3.0 V (two LR6 AA-size alkaline batteries)	DC 9.0 V (one 6LR61 alkaline battery)
Battery life (at 25 °C (77 °F), with Sony LR6 AA-size alkaline batteries)* :	Approx. 6 hours at 50 mW output Approx. 13 hours at 10 mW output	Approx. 8 hours (AU-type) Approx. 6 hours (USA-type)	Approx. 2.5 hours at 250 mW output Approx. 4 hours at 50 mW output
Dimensions (W x H x D):	63 x 83 x 17 mm (2 1/2 x 3 3/8 x 11/16 inches)	63 x 103 x 17 mm (2 1/2 x 4 1/8 x 11/16 inches)	44 x 106 x 44 mm (1 3/4 x 4 1/4 x 1 3/4 inches)
Mass:	Approx. 140 g (4.9 oz) including batteries	Approx. 145 g (5.1 oz) including batteries	Approx. 230 g (8.1 oz) including battery
Supplied accessories:	Soft case (1), Spare battery case (1), Microphone cable (1), Operating instructions (1)	Leatherette case (1), Operating instructions (1)	Soft case (1), Operating instructions (1)

\*When not supplying power to the microphone

# Specifications

## Portable Tuners

	WRR-862A/862B	WRR-855A/855B	WRR-861A/861B
Receiving channels:	2 channels	1 channel	1 channel
Receiving frequency range:	2 frequencies within 566 MHz to 590 MHz (U30/32) 2 frequencies within 638 MHz to 662 MHz (U42/44) 2 frequencies within 758 MHz to 782 MHz (U62/64) 2 frequencies within 782 MHz to 806 MHz (U66/68) 2 frequencies within 792 MHz to 806 MHz (AU66)	566 MHz to 590 MHz (U30/32) 638 MHz to 662 MHz (U42/44) 758 MHz to 782 MHz (U62/64) 782 MHz to 806 MHz (U66/68) 792 MHz to 806 MHz (AU66)	566 MHz to 590 MHz (U30/32) 638 MHz to 662 MHz (U42/44) 758 MHz to 782 MHz (U62/64) 782 MHz to 806 MHz (U66/68) 792 MHz to 806 MHz (AU66)
Local oscillators:	1st: PLL synthesizer, 2nd: Crystal oscillator	1st: PLL synthesizer, 2nd: Crystal oscillator	1st: PLL synthesizer, 2nd: Crystal oscillator
De-emphasis:	50 µs	50 µs	50 µs
Reference deviation:	±5 kHz deviation at 1 kHz modulation (Maximum deviation: ±40 kHz deviation at 1 kHz modulation)	±5 kHz deviation at 1 kHz modulation (Maximum deviation: ±40 kHz deviation at 1 kHz modulation)	±5 kHz deviation at 1 kHz modulation (Maximum deviation: ±40 kHz deviation at 1 kHz modulation)
Selectivity:	60 dB or more at ±250 kHz	60 dB or more at ±250 kHz	60 dB or more at ±250 kHz
Spurious rejection:	70 dB or more	80 dB or more	70 dB or more
Frequency range:	40 Hz to 18 kHz (typical)	40 Hz to 18 kHz (typical)	40 Hz to 18 kHz (typical)
Signal-to-noise ratio:	60 dB or more (65 dB typical) at 60 dBµ RF input at reference deviation, A-weighted	60 dB or more at 60 dBµ RF input at reference deviation, A-weighted	60 dB or more (65 dB typical) at 60 dBµ RF input at reference deviation, A-weighted
RF muting (squelch) level:	5 dBµ, 10 dBµ, 15 dBµ or OFF	10 dBµ or OFF	5 dBµ, 10 dBµ, 15 dBµ or OFF
Audio output level:	-58 dBm at reference deviation	-40 dBu at reference deviation	-58 dBm at reference deviation
Audio output connector:	SMC9-4S (Sony 4-pin, x 2), balanced	D-sub 15-pin (1), unbalanced	SMC9-4S (Sony 4-pin) (1), balanced
Antenna connector:	BNC-R type (2), 50 Ω (nominal)	BNC-R type (2), 50 Ω (nominal)	BNC-R type (2), 50 Ω (nominal)
Monitor output connector:	3.5 mm dia. mini jack (x 1, 5 mW), Tuner 1/2/Mixed selectable	—	3.5 mm dia. stereo mini jack (x 1, 5 mW)
Operating voltage:	Batteries: DC 6 V (four LR6 AA-size alkaline batteries) External: DC 12 V	External: DC 7 V	Batteries: DC 6 V (four LR6 AA-size alkaline batteries) External: DC 12 V
Battery life (at 25 °C (77 °F), with Sony LR6 AA-size alkaline batteries):	Approx. 5 hours	—	Approx. 8 hours
Current (power) consumption:	Batteries: approx. 230 mA at DC 6 V External: approx. 135 mA at DC 12 V	200 mA or less at external DC 7 V	Batteries: approx. 140 mA at DC 6 V External: approx. 85 mA at DC 12 V
Dimensions (W x H x D):	89.0 x 120.0 x 29.5 mm (3 5/8 x 4 3/4 x 1 3/16 inches)	88.0 x 119.0 x 31.3 mm (3 1/2 x 4 3/4 x 1 1/4 inches)	89.0 x 120.0 x 29.5 mm (3 5/8 x 4 3/4 x 1 3/16 inches)
Mass:	Approx. 400 g (14.1 oz) including batteries	Approx. 280 g (10.0 oz)	Approx. 400 g (14.1 oz) including batteries
Supplied accessories:	Attachment case (1), Mounting plate for use with optional A-8278-057A mounting bracket (1), Antennas (1 pair), Output cables (2), DC cable (1), Operating instructions (1)	Antennas (1 pair), Operating instructions (1)	Attachment case (1), Mounting plate for use with optional A-8278-057A mounting bracket (1), Antennas (1 pair), output cable (1), DC cable (1), Operating instructions (1)

## Tuners

	WRU-8N	WRU-806A/806B
Receiving channels:	1 channel	1 channel
Receiving frequency range:	566 MHz to 590 MHz (U30/32) 638 MHz to 662 MHz (U42/44) 758 MHz to 782 MHz (U62/64) 782 MHz to 806 MHz (U66/68) 792 MHz to 806 MHz (AU66)	566 MHz to 590 MHz (U30/32) 638 MHz to 662 MHz (U42/44) 758 MHz to 782 MHz (U62/64) 782 MHz to 806 MHz (U66/68) 792 MHz to 806 MHz (AU66)
Local oscillators:	PLL synthesizer	1st: PLL synthesizer, 2nd: Crystal oscillator
De-emphasis:	50 µs	50 µs
Reference deviation:	±5 kHz deviation at 1 kHz modulation (Maximum deviation: ±40 kHz deviation at 1 kHz modulation)	±5 kHz deviation at 1 kHz modulation (Maximum deviation: ±40 kHz deviation at 1 kHz modulation)
Selectivity:	60 dB or more at ±250 kHz	60 dB or more at ±250 kHz
Frequency range:	40 Hz to 20 kHz (typical)	70 Hz to 18 kHz (typical)
Signal-to-noise ratio:	60 dB or more (65 dB typical) at 60 dBµ RF input at reference deviation, A-weighted	60 dB or more at 60 dBµ RF input at reference deviation, deviation, A-weighted
RF muting (squelch) level:	10 dBµ, 20 dBµ, 30 dBµ or off	30 dBµ
Operating voltage:	DC 5 V (supplied from MB-8N)	DC 9 V (supplied from MB-806A)
Current (power) consumption:	260 mA or less	225 mA or less
Dimensions (W x H x D):	56.0 x 30.7 x 149.0 mm (2 1/4 x 1 1/4 x 5 7/8 inches)	57 x 26 x 122 mm (2 1/4 x 1 1/16 x 4 7/8 inches)
Mass:	Approx. 165 g (5.8 oz)	Approx. 160 g (5.7 oz)
Supplied accessories:	—	Operating instructions (1)

0 dB SPL = 20 $\mu$  Pa  
 0 dBV = 1 Vrms  
 1 dBu = 0.775 Vrms  
 1 dB $\mu$  = 1 $\mu$ V<sub>EMF</sub>

## Tuner Base Units

	MB-8N	MB-806A	MB-X6
Receiving channels:	4 channels when accommodating 4 WRU-8N tuner modules	6 channels when accommodating 6 WRU-806A/806B tuner modules	6 channels when accommodating 6 WRU-806A/806B tuner modules
Receiving frequency range:	566 MHz to 806 MHz (USA type) 758 MHz to 862 MHz (AU type)	758 MHz to 806 MHz (USA type) 758 MHz to 862 MHz (AU type)	758 MHz to 806 MHz (USA type) 758 MHz to 862 MHz (AU type)
Audio output level:	-20 dBm (LINE)/-58 dBm (MIC) at reference deviation	-20 dBm (LINE)/-58 dBm (MIC) at reference deviation	-20 dBu (LINE)/-58 dBu (MIC) at reference deviation
Audio output connector:	XLR-3-32 type (4), balanced D-sub 15-pin (1) for sub output, female, unbalanced	XLR-3-32 (7), balanced	XLR-3-32 (7), balanced
Antenna attenuator level:	0 dB, 5 dB, 10 dB, 15 dB	0 dB or 10 dB	0 dB or 10 dB
Antenna connector:	Inputs: BNC-R type (x 2), 50 $\Omega$ (nominal) Outputs (for cascade connection): BNC-R type (2), 50 $\Omega$ (nominal)	Inputs: BNC-R type (2), 50 $\Omega$ (nominal)	Inputs: BNC-R type (2), 50 $\Omega$ (nominal)
Monitor output level:	5 mW or more (24 to 45 $\Omega$ load)	—	—
Monitor output connector:	6.3 mm dia, stereo mini jack (1)	—	—
Network connector:	RJ-45 (1), 10BASE-T	—	—
Operating voltage:	AC 120 V, 60 Hz (USA-type) AC 100 to 240 V, 50/60 Hz (AU-type)	AC 120 V, 60 Hz (USA-type) AC 220 to 240 V, 50/60 Hz (AU-type)	AC 120 V, 60 Hz (USA-type) AC 230 V, 50/60 Hz (AU-type)
Current (power) consumption:	50 W when accommodating four WRU-8N tuner modules	30 W when accommodating six WRU-806A/806B tuner modules	30 W when accommodating six WRU-806A/806B tuner modules
Dimensions (W x H x D):	482 x 44 x 300 mm (19 x 1 3/4 x 11 7/8 inches)	482 x 44 x 300 mm (19 x 1 3/4 x 11 7/8 inches)	482 x 44 x 285 mm (19 x 1 3/4 x 11 1/4 inches)
Mass:	Approx. 3.7 kg (8 lb 6 oz)	Approx. 3.6 kg (7 lb 15 oz)	Approx. 5.5 kg (12 lb 2 oz)
Supplied accessories:	AC power cord (1), Antennas (1 pair), CD-ROM (contains operating instructions and MB-8N supplied software) (1)	AC power cord (1), Antennas (1 pair), Operating instructions (1)	AC power cord (1), Antennas (1 pair), Operating instructions (1)

## Antenna Dividers

	WD-850	WD-880A
Frequency range:	566 MHz to 806 MHz (USA type) 758 MHz to 862 MHz (AU type)	770 MHz to 806 MHz (USA type) 792 MHz to 806 MHz (AU type)
Channel distribution:	Inputs: 2 pairs Outputs: 4 pairs	USA type: Inputs: 1 pair Outputs: 6 pairs (for 6 TV channels) AU type: Inputs: 2 pairs Outputs: 3 pairs
Input/output impedance:	50 $\Omega$	50 $\Omega$
Cascade output:	1 pair	USA type: 0 AU type: 1 pair
Power supply for antenna booster: (supplied from antenna input connectors)	DC 12 V/9 V/OFF switchable	DC 12 V/9 V/OFF switchable
Power consumption:	16 W	10 W
Dimensions (W x H x D):	482 x 44 x 300 mm (19 x 1 3/4 x 11 7/8 inches)	482 x 44 x 300 mm (19 x 1 3/4 x 11 7/8 inches)
Mass:	Approx. 4.6 kg (10 lb 2 oz)	Approx. 4.0 kg (8 lb 13 oz)
Supplied accessories:	50 $\Omega$ BNC terminators (6)	AC power cord (1)

## Multi-channel simultaneous operations

The Sony wireless microphone system allows a wide variety of multi-channel systems to be flexibly configured to meet individual requirements.

The number of channels that can be simultaneously operated using **One Version of B-series (USA-type) Products** (without use of a WD-880A) is as follows;

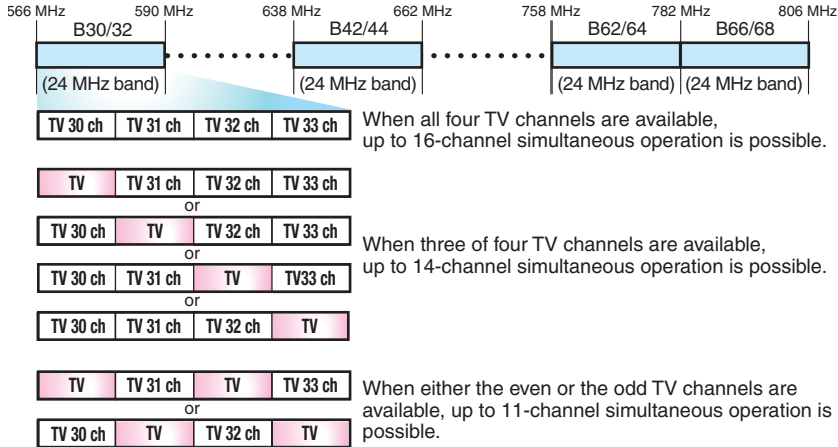

The number of channels that can be simultaneously operated using **the B30/32 and B62/64 Combination** (without use of a WD-880A) is as follows;

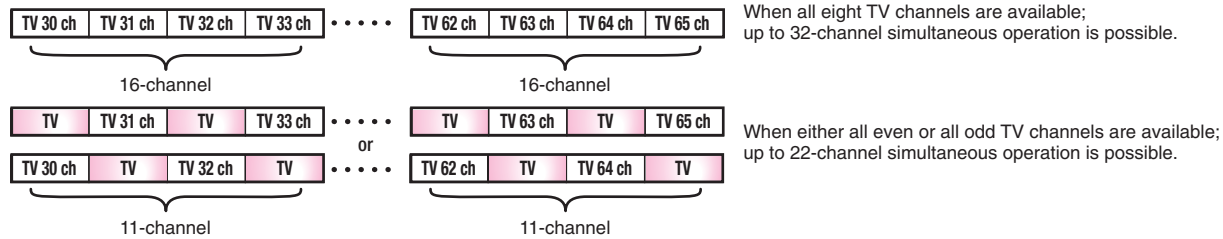

The number of channels that can be simultaneously operated using **the B62/64 and B66/68 Combination** (without use of a WD-880A) is as follows;

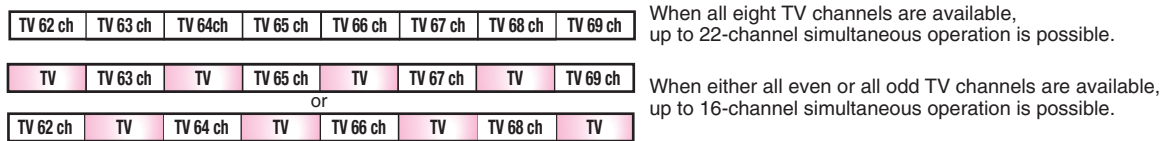

The number of channels that can be simultaneously operated using **the B30/32, B42/44 and B62/64 Combination** (without use of a WD-880A) is as follows;

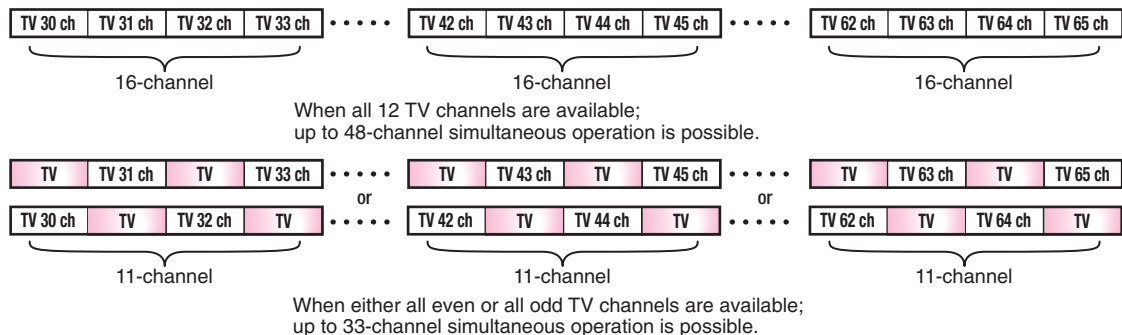



The number of channels that can be simultaneously operated using **the All B-series Combination** (without use of a WD-880A) is as follows;

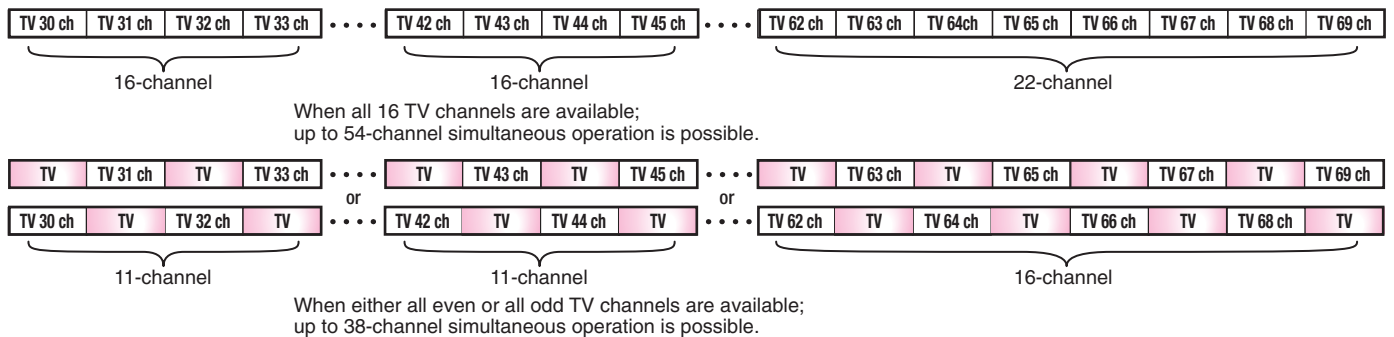

The number of channels that can be simultaneously operated using **One Version of A-series (USA-type) Products** (without use of a WD-880A) is as follows;

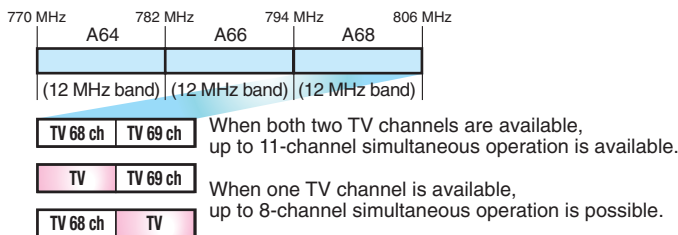

The number of channels that can be simultaneously operated using **Two of the Three A-series (USA-type) Products** (without use of a WD-880A) is as follows;

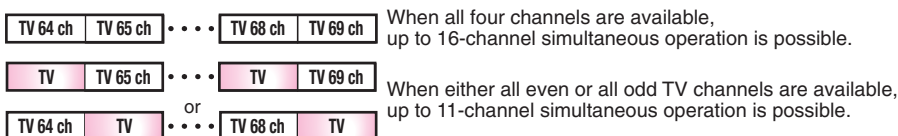

The number of channels that can be simultaneously operated using **All USA-Type A64/A66/A68 Combination** (without use of a WD-880A) is as follows;

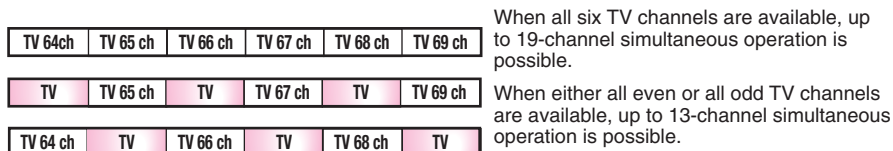



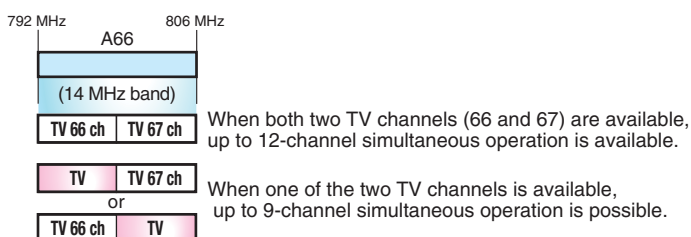













The number of channels that can be simultaneously operated using **the AU Products** (without use of a WD-880A) is as follows;



## Tuner and Camcorder Combinations

		HDCAM Camcorders		Digital Betacam Camcorders	XDCAM Camcorders	
		HDW-F900R/750/750P	HDW-730S	DVW-970/970P	PDW-530/530P/510/510P	
						
Camcorder/ Tuner Interfaces	<b>Built-in Wireless Slot</b>	Yes	Yes	Yes	Yes	
	<b>DC Output for Wireless Tuner</b>	Yes	Yes	Yes	Yes	
	<b>Mic-input Connector</b>	XLR 5-pin (x1)	XLR 3-pin (x1)	XLR 3-pin (x1)	XLR 3-pin (x1)	
	<b>Audio-input Connector</b>	XLR 3-pin (x2)	XLR 3-pin (x2)	XLR 3-pin (x2)	XLR 3-pin (x2)	
Applicable Wireless Microphone Tuners		<b>WRR-855A/855B (1ch)</b>	<b>WRR-855A/855B (1ch)</b>	<b>WRR-855A/855B (1ch)</b>	<b>WRR-855A/855B (1ch)</b>	
						
		Direct slot-in	Direct slot-in	Direct slot-in	Direct slot-in	
		<b>WRR-861A/861B (1ch)</b>	<b>WRR-861A/861B (1ch)</b>	<b>WRR-861A/861B (1ch)</b>	<b>WRR-861A/861B (1ch)</b>	
		 Requires A-8278-057-A Mount Bracket	 Requires A-8278-057-A Mount Bracket	 Requires A-8278-057-A Mount Bracket	 Requires A-8278-057-A Mount Bracket	
						
<b>WRR-862A/862B (2ch)</b>	<b>WRR-862A/862B (2ch)</b>	<b>WRR-862A/862B (2ch)</b>	<b>WRR-862A/862B (2ch)</b>			
						
Requires A-8278-057-A Mount Bracket	Requires A-8278-057-A Mount Bracket	Requires A-8278-057-A Mount Bracket	Requires A-8278-057-A Mount Bracket			
						

	MPEG IMX Camcorders	XDCAM HD Camcorders	DVCAM Camcorders	
	<b>MSW-970/970P</b> 	<b>PDW-F350/F330</b> 	<b>DSR-400/400P/450WS/450WSP</b> 	<b>DSR-250/250P</b> 
	Yes	No	No	No
	Yes	Yes	Yes	Yes
	XLR 3-pin (x1)	XLR 5-pin (x1)	XLR 3-pin (x1)	XLR 3-pin (x1)
	XLR 3-pin (x2)	XLR 3-pin (x2)	XLR 3-pin (x2)	XLR 3-pin (x2)
	<b>WRR-855A/855B (1ch)</b>  Direct slot-in	<b>WRR-855A/855B (1ch)</b>  Requires CA-WR855 Mount Adaptor 	<b>WRR-855A/855B (1ch)</b>  Requires CA-WR855 Mount Adaptor 	—
	<b>WRR-861A/861B (1ch)</b>  Requires A-8278-057-A Mount Bracket 	<b>WRR-861A/861B (1ch)</b>  Requires A-8278-057-A Mount Bracket 	<b>WRR-861A/861B (1ch)</b>  Requires A-8278-057-A Mount Bracket 	<b>WRR-861A/861B (1ch)</b>  Requires A-8278-057-A Mount Bracket 
	<b>WRR-862A/862B (2ch)</b>  Requires A-8278-057-A Mount Bracket 	<b>WRR-862A/862B (2ch)</b>  Requires A-8278-057-A Mount Bracket 	<b>WRR-862A/862B (2ch)</b>  Requires A-8278-057-A Mount Bracket 	<b>WRR-862A/862B (2ch)</b>  Requires A-8278-057-A Mount Bracket 

# SONY®

Use of Sony wireless devices in the United States of America is regulated by the Federal Communications Commission as described in Parts 15 and 74 of the FCC regulations. Users authorized thereby are required to obtain an appropriate license.

---

**Distributed by**

©2006 Sony Corporation. All rights reserved.  
Reproduction in whole or in part without written permission is prohibited.  
Features and specifications are subject to change without notice.  
All non-metric weights and measures are approximate.  
Sony is a registered trademark of Sony Corporation.  
Digital Betacam, DVCAM, HDCAM, MPEG IMX and XDCAM are trademarks of Sony Corporation.