



After the Vegas software is installed and you start it for the first time, the registration wizard appears. This wizard offers easy steps that allow you to register the software online with Sony Pictures Digital Media Software and Services. Alternatively, you may register online at <http://www.sony.com/mediasoftware> at any time.

Registering your product will provide you with exclusive access to a variety of technical support options, notification of product updates, and special promotions exclusive to Vegas registered users.

Registration Assistance

If you do not have access to the Internet, registration assistance is available during normal weekday business hours. Please contact our Customer Service Department by dialing one of the following numbers:

Telephone/Fax	Country
1-800-577-6642 (toll-free)	US, Canada, and Virgin Islands
+608-204-7703	for all other countries
1-608-250-1745 (Fax)	All countries

Customer Service/Sales

For a detailed list of Customer Service options, we encourage you to visit <http://mediasoftware.sonypictures.com/support/custserv.asp>. Use the following numbers for telephone support during normal weekday business hours:

Telephone/Fax/E-mail	Country
1-800-577-6642 (toll-free)	US, Canada, and Virgin Islands
+608-204-7703	for all other countries
1-608-250-1745 (Fax)	All countries
http://mediasoftware.sonypictures.com/custserv	

Technical Support

For a detailed list of Technical Support options, we encourage you to visit <http://mediasoftware.sonypictures.com/support/default.asp>. To listen to your support options, please call 608-256-5555.

Sony Pictures Digital Inc.

Media Software and Services

1617 Sherman Avenue

Madison, WI 53704

USA

The information contained in this manual is subject to change without notice and does not represent a guarantee or commitment on behalf of Sony Pictures Digital Inc. in any way. All updates or additional information relating to the contents of this manual will be posted on the Sony Pictures Digital Media Software web site, located at <http://www.sony.com/mediasoftware>. The software is provided to you under the terms of the End User License Agreement and Software Privacy Policy, and must be used and/or copied in accordance therewith. Copying or distributing the software except as expressly described in the End User License Agreement is strictly prohibited. No part of this manual may be reproduced or transmitted in any form or for any purpose without the express written consent of Sony Pictures Digital Inc.

Vegas, Vegas+DVD, DVD Architect, ACID, ACIDized, and Sound Forge are trademarks or registered trademarks of Sony Pictures Digital Inc. or its affiliates in the United States and other countries. ASIO is a trademark and VST is a registered trademark of Steinberg Media Technologies AG. All other trademarks or registered trademarks are the property of their respective owners in the United States and other countries.

Copyright 2004. Sony Pictures Digital Inc.

Program Copyright 2004. Sony Pictures Digital Inc. All rights reserved.

Table of Contents

Introduction	15
Welcome	15
System requirements	15
Technical support	15
Installing Vegas software	16
Registration	16
Using online help	16
Overview	18
Main window	18
Toolbar	18
Time display	19
Ruler	19
Marker bar	19
Command bar	19
CD layout bar	20
Track list	20
Timeline	20
Transport bar controls	20
Status bar	20
Scrub control	21
Window docking area and floating window docks	21
Saving and recalling window layouts - Ctrl+Alt+D or Ctrl+D	25
Keyboard command reference	26
Cursor indications	32
Using a control surface	33
Audio signal flow	34
Video signal flow	35
About your rights in Vegas software	36
About Your Privacy	36
Proper Use of Software	36

Getting Started	37
Creating projects	37
Setting video properties based on a media file	38
Saving a project	38
Renaming a project (using Save As)	39
Getting media files	39
Selecting media	40
Previewing a media file	40
Using the Media Pool	41
Adding media to the timeline	46
Working with events	48
Understanding files and events	48
Moving events along the timeline	48
Working with tracks	50
Using the track view	50
Using the track list	52
Playing back and previewing	54
Playing your project	54
Scrubbing	55
Previewing to media player	56
Prerendering video previews	56
Rendering a project	57
Creating a movie	57
Basic Editing Techniques	59
Getting around	59
Moving the cursor	59
Changing focus	59
Making selections	60
Selecting multiple events	60
Selecting a time range	61
Looping playback	62
Selecting events and a time range	62
Selecting tracks	62
Selecting groups of composited tracks	63
Editing events	63
Copying events	63
Cutting events	64
Pasting events	65
Duplicating events	67

Inserting empty events and time	67
Trimming events	67
Splitting events	69
Slipping and sliding events	71
Deleting events	72
Applying post-edit ripples	73
Applying a post-edit ripple manually	74
Applying a post-edit ripple automatically	74
Shuffling events	75
Crossfading events	75
Using automatic crossfades	75
Manually setting a crossfade	76
Changing crossfade curves	76
Sliding a crossfade	76
Using undo and redo	77
Using undo	77
Using redo	78
Clearing the edit history	78
Adding project markers and regions	78
Working with markers	79
Working with regions	80
Working with command markers	82
Working with CD layout markers	85
Working with the marker tool	85
Using an external audio editing program	85
Setting up an audio editing program	85
Opening an audio editor from Vegas software	87
Advanced Editing Techniques	89
Snapping events	89
Turning snapping on and off	89
Quantizing to frames	89
Using the event snap offset	90
Snapping to the cursor or a selection	90
Pitch shifting audio events	91
Editing from the timeline	91
Editing in the Event Properties dialog	92
Time compressing/stretching events	93
Time compressing/stretching video	93

Working with takes	94
Adding takes	94
Selecting takes	94
Previewing and selecting takes	95
Deleting takes	95
Working with take names	95
Using the Trimmer window	96
Opening a file in the Trimmer	96
Moving frame-by-frame in the Trimmer window	97
Making selections in the Trimmer	97
Adding selections to the timeline	97
Adding and saving regions and markers to a media file	99
Opening a file in an external audio editor from the Trimmer	100
Creating a subclip	100
Selecting a subclip in its parent media	101
Using the Edit Details window	101
Viewing the Edit Details window	102
Customizing the Edit Details window	104
 Working with Tracks	 105
Managing tracks	105
Inserting an empty track	105
Duplicating a track	106
Deleting a track	106
Naming or renaming a track	106
Organizing tracks	107
Reordering tracks	107
Changing track color	107
Changing track height	108
Using the track list	108
Using the volume fader (audio only)	109
Using the multipurpose slider (audio only)	110
Assigning audio tracks to assignable effects chains	111
Assigning audio tracks to busses	111
Adjusting the composite level (video only)	112
Selecting the compositing mode	112
Bypassing motion blur envelopes (video only)	113
Using track motion (video only)	113
Phase inverting a track (audio only)	113
Muting a track	113
Muting all audio or video tracks	113
Soloing a track	114

Setting default track properties	114
Track automation envelopes	114
Using audio bus tracks	114
Adding envelopes to an audio bus track	115
Adding effects to audio bus tracks	115
Muting or soloing an audio bus track	115
Resizing audio bus tracks	115
Using video bus tracks	115
Adding keyframes to the video bus track	115
Adding envelopes to the video bus track	115
Adding effects to video bus tracks	116
Muting the video output	116
Bypassing video effects and envelopes	116
Resizing video bus tracks	116
Rendering to a new track	116
Using Automation	119
Showing or hiding automation controls	119
Track automation	119
Mute automation (audio and video)	119
Volume or pan automation (audio only)	120
Assignable effects automation (audio only)	121
Bus automation (audio only)	122
Adding or removing track effect automation	122
Composite level automation (video only)	124
Adding a motion blur envelope	125
Adding a video supersampling envelope	125
Working with track envelopes	126
Hiding track envelopes	128
Removing track envelopes	128
Using the Envelope Edit tool	128
Locking envelopes to events	129
Automating 5.1 surround projects	130
Automation recording modes	130
Recording automation settings	130
Editing sections of your recorded settings in Touch mode	131
Overwriting recorded settings in Latch mode	131
Editing individual envelope points or keyframes	132
Setting the automation recording mode for a track	132
Working with Events	133

Setting event switches	133
Mute	133
Lock	133
Loop	133
Invert phase (audio only)	134
Normalize (audio only)	134
Maintain aspect ratio (video only)	135
Reduce interlace flicker (video only)	135
Resample (video only)	135
Accessing event properties	136
Adjusting audio channels	136
Copying and pasting event attributes	137
Using audio event envelopes (ASR)	137
Setting an audio event's volume	137
Setting an event's fade in and out	138
Using video event envelopes	138
Using opacity envelopes	139
Using velocity envelopes	139
Grouping events	141
Creating a new group	141
Adding an event to an existing group	142
Removing events from a group	142
Clearing a group	142
Selecting all members of a group	142
Suspending grouping temporarily	142
Cutting, copying, or deleting grouped events	142
Using the Mixer	143
Using the Mixer window	143
Viewing the Mixer window	143
Using the Mixer toolbar	144
Using the Mixer Preview fader	144
Using busses	145
Adding busses to a project	145
Deleting busses from a project	147
Routing a bus to another bus	147
Routing busses to hardware	147
Working with busses	148
Assigning audio tracks to busses	149

Using assignable effects chains	150
Assigning audio tracks to assignable effects chains	151
Routing assignable effects chains to busses	152
Automating busses and assignable effects	152
Viewing bus tracks	152
Adding track envelopes	152
Modifying track envelopes	152
Adding Audio Effects	153
Using audio effects	153
Using plug-in chains	154
Creating a plug-in chain	154
Adding plug-ins to a plug-in chain	154
Saving customized plug-in presets	156
Arranging the order of plug-ins	156
Bypassing plug-ins on the chain	157
Removing plug-ins from a chain	157
Saving plug-in chains	159
Editing saved plug-in chains	159
Organizing your plug-ins	160
Automating effects parameters	160
Applying non-real-time event effects	160
Bypassing all audio effects	161
Recording Audio	163
Setting up your equipment	163
Basic setup	163
Setup with mixer	164
Setup with digital multitrack	164
Preparing to record	165
Arming the track for recording	165
Selecting recording settings	166
Using the metronome	167
Recording	167
Recording into an empty track	167
Recording into a time selection	168
Recording into an event	168
Recording into an event with a time selection	169
Triggering from MIDI timecode	170
Working with multiple recorded takes	170

Specifying where recordings are stored	170
Changing where recorded files are stored when arming a track	170
Changing where recorded files are stored when starting to record	171
Changing where recorded files are stored in the Project Properties dialog	171
Monitoring audio levels	171
Using record input monitoring	171
Working with 5.1 Surround	173
What is 5.1 surround?	173
Setting up surround hardware	174
Setting up surround projects	174
Routing to hardware in the mixer	175
Assigning audio to the LFE channel	176
Adjusting volume	176
Adjusting track volume	176
Adjusting assignable effects send or bus send levels	177
Adjusting channel levels	177
Panning audio	178
Panning tracks	178
Panning mixer controls	179
Using the Surround Panner window	180
Automating panning	182
Turning on panning keyframes	182
Adding panning keyframes	182
Working with keyframes	183
Rendering surround projects	185
Creating a DVD with DVD Architect Software	186
Using Advanced Video Features	187
Cropping video	187
Cropping	188
Bézier masks	189
Rotating	189
Adding animation	189
Working with still images	190
Creating still images for use in Vegas software	190
Capturing a timeline snapshot	191
Creating a slide show	191

Creating titles	192
Creating titles from images	192
Fading titles	193
Adding closed captioning to Windows Media Video (WMV) files	193
Adding closed captioning line-by-line	194
Adding closed captioning from a script	194
Displaying closed captioning	196
Resampling video	197
Using Edit Decision Lists (EDL)	198
Creating an EDL	198
Opening an EDL	198
Working in DV format	198
Selecting source media	199
Setting project properties	199
Selecting templates	199
Eliminating out-of-range colors	200
Modifying video properties	201
Modifying project video properties	201
Modifying media file properties	202
Modifying output properties	203
Using Video FX, Compositing, and Masks	205
Using video effects	205
Adding a video effects plug-in	206
Working with video effects plug-in chains	208
Modifying a video effects plug-in	210
Saving custom plug-in settings as a preset	210
Using keyframe animation with plug-ins	210
Using generated media	211
Adding a generated media event	211
Duplicating a generated media event	212
Compositing	212
Understanding the parent/child track relationship	212
Selecting compositing modes	213
Using a 2-to-1 transform plug-in to customize compositing	216
3D Compositing	216
Single-track 3D motion	217
Composited group 3D motion	218
Changing editing options	219
Examples of various 3D compositing scenarios	219

Creating masks	220
Creating image masks	221
Creating video masks	222
Bézier masks [Bezier]	223
Fine-tuning masks	225
Using the Mask Generator	226
Chroma keying	228
Adding Video Transitions and Motion	231
Understanding basic transitions	231
Cuts	231
Crossfades	231
Using transition effects	231
Adding a transition	232
Adding a transition to the end of an event	232
Adding a transition to all selected events	233
Adding a transition progress envelope	233
Understanding track layers	234
Converting a cut to a transition	234
Converting a crossfade or transition to a cut	235
Previewing a transition	235
Modifying a transition	236
Saving custom settings as a preset	236
Using keyframe animation	237
Understanding the keyframe controller	237
Adding keyframes	238
Deleting keyframes	238
Navigating in the keyframe controller	238
Modifying keyframes	238
Working with keyframes in track view	240
Sample uses for keyframe animation	241
Animating event panning and cropping	241
Animating video effects plug-ins	243
Animating generated text	244
Adding track motion	245
Controlling track motion	245
Using the track motion shortcut menu	246
Changing editing options	246
Using keyframes in track motion	247
Creating a picture-in-picture effect	250
Animating the overlay	250

Previewing and Analyzing Video	253
Understanding the Video Preview window	253
Using the Video Preview window shortcut menu	254
Optimizing the Video Preview window	255
Reducing preview quality	255
Prerendering video	255
Building dynamic RAM previews	256
Using split-screen previewing	257
Previewing affected and unprocessed video	257
Showing the video at the cursor position and the contents of the clipboard	258
Changing the selection for displaying split-screen views	258
Identifying safe areas	258
Viewing the grid	259
Isolating color channels	259
Monitoring video with scopes	259
Displaying chrominance using the vectorscope monitor	260
Displaying luminance using the waveform monitor	261
Displaying color levels and contrast using the histogram monitor	262
Displaying RGB components with RGB parade monitor	263
Adjusting video scope settings	264
Previewing in a player	265
Using an external monitor	266
Setting up an external monitor	266
Configuring an external monitor	267
Verifying the external monitor configuration	267
Saving, Rendering, and Printing Projects	269
Saving a project	269
Creating a copy of a project (using Save As...)	270
Saving a project with media	270
Autosaving a project	271
Rendering a project	271
Selecting a file format	272
More about the MPEG format	273
More about the Wave64 and Perfect Clarity Audio formats	273
More about video formats	273
Customizing the rendering process	275
Customizing the Render As settings	275
Saving custom settings as a template	276

Creating custom rendering settings for AVI files	276
Project tab	276
Video tab	276
Audio tab	278
Rendering with networked computers	279
Setting up your computers for network rendering	279
Troubleshooting initiation problems	281
Using nondistributed network rendering	281
Using distributed network rendering	282
Monitoring rendering progress	282
Setting file mappings	283
Setting render service options	283
Printing with Video Capture	284
Printing to DV tape	284
Establishing a connection to the recording device	284
Printing to DV tape from the timeline	285
Customizing Vegas software	287
Displaying frame numbers	287
Changing the ruler format	287
Editing the ruler offset	288
Changing grid spacing	289
Using the Time Display window	289
Changing the time display settings	289
Changing the time display colors	290
Setting the time display to monitor MIDI timecode	290
Working with project properties	291
Video tab	291
Audio tab	291
Ruler tab	292
Summary tab	292
Audio CD tab	292
Using the toolbar	292
Hiding and displaying the toolbar	292
Reordering toolbar buttons	293
Adding buttons to the toolbar	293
Removing buttons from the toolbar	293

Setting preferences	294
General tab	294
Video tab	296
Video device tab	296
Audio tab	297
Audio Device tab	297
MIDI Tab	299
Editing tab	299
Display tab	300
CD Settings tab	300
Sync tab	301
Keyboard tab	302
External Control & Automation tab	303
Burning CDs	305
Understanding track-at-once and disc-at-once	305
Track-at-once	305
Disc-at-once (Single Session or Red Book)	305
Understanding tracks and indices	305
Setting up to burn audio CDs	306
Viewing the ruler and time display	306
Setting project properties	306
Setting preferences	306
Importing CD Architect files	306
Creating audio CD layout projects	307
Adding media as CD tracks to a new project	307
Marking tracks in an existing project	308
Working with tracks and indices	309
Navigating to and selecting tracks and indices	309
Moving track and index markers	309
Renaming track and index markers	309
Deleting track and index markers	309
Editing markers using the Edit Details window	310
Copying a track list from the Edit Details window	310
Burning audio CDs	310
Burning single tracks (track-at-once)	310
Burning a disc (disc-at-once)	311
Burning video CDs	312
Creating a multimedia CD	314
Using Scripting	315

Running a script.	315
Adding scripts to the Scripting menu.	316
Creating a script.	316
Editing an existing script	316
Troubleshooting.	317
Troubleshooting resources.	317
Common questions	317
Why are some of my DirectX plug-ins not working correctly?	317
Why do I hear gaps in my audio playback?	317
Why do mono events increase 6 dB when panning a track hard?	318
Why do buffer underruns occur during a test or real write to a CD?	318
Why can't I work with footage captured using an MJPEG card?	319
Trouble-free video: software solutions.	320
Trouble-free video: hardware solutions.	320
Video subsystem	320
Hard disk	321
CPU and RAM (memory)	321
Audio proxy files (.sfap0).	322
Interlacing and field order	322
Timecode	324
SMPTE timecode types	324
Timecode in Vegas software	325
Troubleshooting DV hardware issues	326
Glossary	327
Index	i

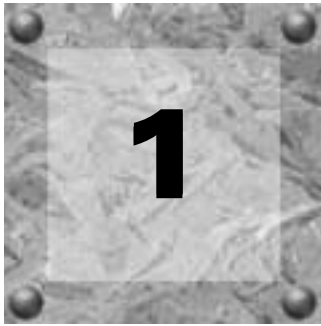

Introduction

Welcome

Vegas® software from Sony Pictures Digital is an innovative and advanced multitrack media-editing system. Vegas software was designed to create an efficient audio/video production environment without sacrificing the quality and processing power that you expect from Sony Pictures Digital. Whether it's the standard and familiar Microsoft® Windows® navigation commands or the clean and uncluttered interface, you'll find Vegas software to be a tool that will be mastered in minutes. Beneath the unique and customizable interface, you'll find a product that is both powerful and flexible.

System requirements



In order to use Vegas software, your computer must satisfy the following minimum specifications:

- Microsoft® Windows® 2000 or XP
- 500 MHz processor
- 150 MB hard-disk space for program installation
- 128 MB RAM
- OHCI compatible i.LINK® connector/IEEE-1394DV card (for DV capture and print-to-tape)
- Microsoft Windows-compatible sound card
- CD-ROM drive (for installation from a CD only)
- CD-Recordable drive (for CD burning only)
- Microsoft DirectX® 8 or later (included on CD-ROM)
- Microsoft .NET Framework
- Microsoft Internet Explorer 5.0 or later (included on CD-ROM)
- QuickTime™ version 6.0 or later (for .mov, .qt, .dv, .gif, and .tif file support)

Technical support

The Web site at <http://mediasoftware.sonypictures.com/support/default.asp> has technical support, reference information, program updates, tips and tricks, user forums, and a knowledge base.

Installing Vegas software

1. Insert the CD-ROM. The setup screen appears (if CD-ROM AutoPlay is enabled).
If CD-ROM AutoPlay is not enabled, click the  button and choose **Run**. In the Run window that appears, type the CD-ROM drive's letter and add `\setup.exe`. Click **OK** to start the installation.
2. Click **Install Vegas 5.0**. The installation process begins.
3. Follow the screen prompts and enter the necessary information when required.
4. At the last screen prompt, click  to conclude the installation.

Note: *Windows Installer is used for all versions of Windows. Windows Installer is installed and then you are asked to restart your system.*

Registration

The registration dialog that appears when you start the software allows you to quickly and easily register:

- Choose **Register online** to instantly register the product over the Internet.
- Choose **Register from another computer** if the computer you've installed the software on does not have an Internet connection, but you have another computer that does.
- Choose **Register over the phone** to call Sony Pictures Digital to register manually.
- Choose **Register later** to continue using the software for a limited time without registering.

Follow the instructions in the registration dialog to complete your registration.

Using online help

You can access two varieties of help:

- **Online help**
- **What'sThis? help** (also referred to as context-sensitive help)

Online help

To access online help, choose **Contents and Index** from the **Help** menu or press **[F1]**.

Note: *To view online help, Internet Explorer 4.0 or later must be installed on your system. Internet Explorer 5.0 is included on the Vegas software CD-ROM for your convenience.*

The online help window has four tabs that you can use to find the information that you need.

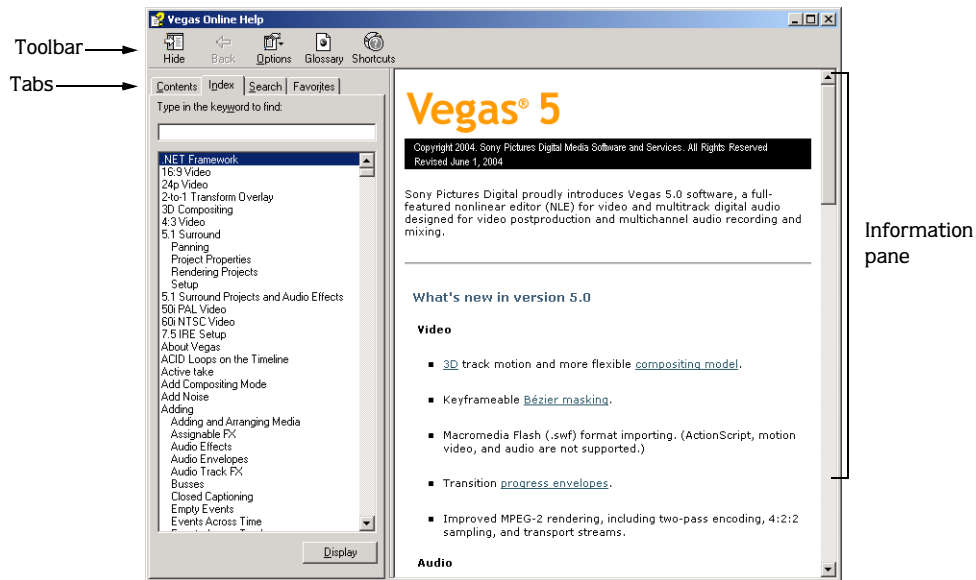

The Contents tab provides a list of available help topics. Double-click a closed book (📖) to open the pages and then click a topic page (🔍).

The Index tab provides a complete listing of the help topics available. Scroll through the list of available topics or type a word in the Type in the keyword to find box to quickly locate topics related to that word. Select the topic and click .

The Search tab allows you to enter a keyword and display all of the topics in the online help that contain the keyword you have entered. Type a keyword in the Type in the word(s) to search for box and click . Select the topic from the list and click .

The Favorites tab allows you to keep topics that you revisit often in a separate folder. To add a topic to your favorites, click on the Favorites tab.

What'sThis? help

What'sThis? help allows you to view pop-up descriptions of menus, buttons, and dialog boxes.

1. Click the What's This Help button (🔍) in the toolbar or the question mark (?) in the upper-right corner of a dialog box. Alternately, you can choose **What's This?** from the **Help** menu or press **Shift + F1**. The cursor changes to a question mark icon (🔍).
2. Click an item in the program's interface. A pop-up description of the item appears.

Help on the Web

Additional help and information is available on the Sony Pictures Digital Media Software and Services Web site. From the **Help** menu, choose **Sony on the Web** to view a listing of Web pages pertaining to Vegas software and Sony Pictures Digital.

Overview

Vegas software is designed to be an easy-to-use program with many tools that provide power and flexibility when creating and working with multimedia files. Many operations, menu items, and shortcut keys are consistent with other popular Microsoft Windows software applications.

The following sections provide a graphical tour of the Vegas workspace.





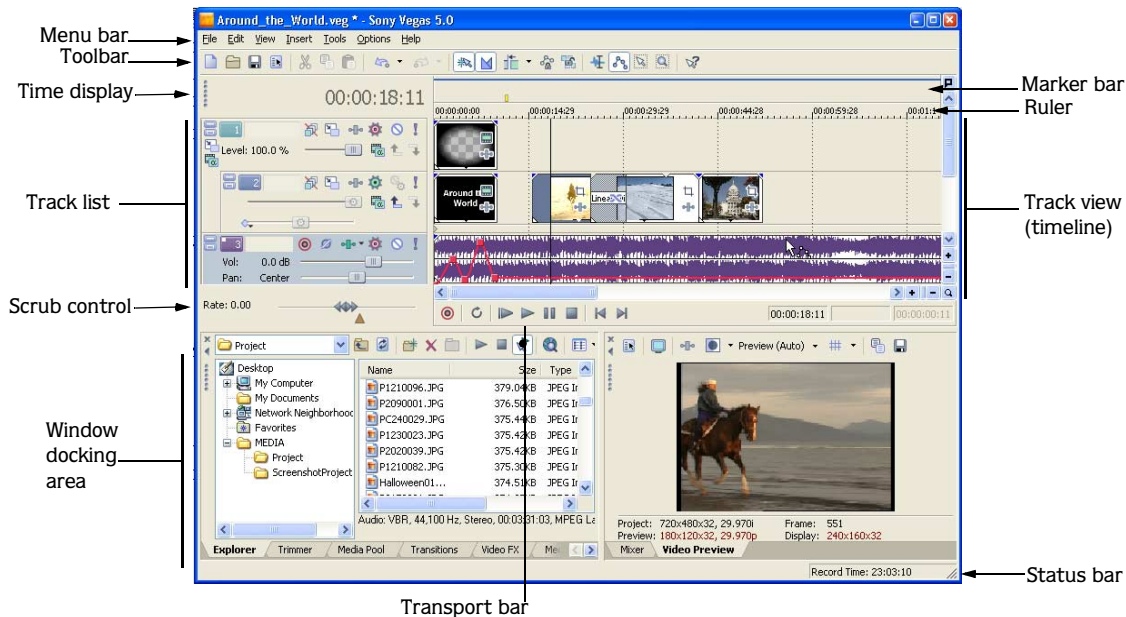













Main window

This is the window that appears when the software is opened. The work area is subdivided into three primary areas: the track list, the track view (or timeline), and the window docking area. You can resize the track list, track view, and window docking area by dragging the dividers between them.



Toolbar

The toolbar allows you to quickly access the most commonly used functions and features. From the **Options** menu, choose **Customize Toolbar** to specify which buttons are displayed.

 Create new project	 Enable automatic crossfades
 Open existing project	 Enable automatic ripple editing
 Save project	 Lock envelopes to events
 Open project properties	 Ignore event grouping
 Cut selected events or time range	 Normal edit tool
 Copy selected events or time range	 Envelope edit tool
 Paste items from clipboard into project	 Selection edit tool
 Undo	 Zoom edit tool
 Redo	 What's This? help
 Enable snapping to grid lines	

Time display

The Time Display window reflects the cursor's position on the timeline and the end point of a time selection. You can customize time display settings, including what time the window displays and colors are used in the display. *For more information, see [Using the Time Display window](#) on page 289.*

You can move the Time Display window from its docked position above the track list to float on the workspace or dock in the window docking area.

Docked position

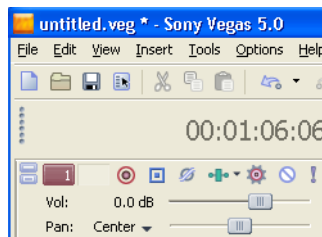

Floating window

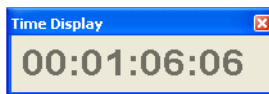

Docked in window docking area

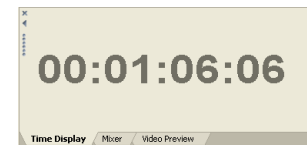

Ruler

The ruler is the timeline for your project. You may specify how the ruler measures time: seconds, measures and beats, frames, etc. *For more information, see [Changing the ruler format](#) on page 287.*



Marker bar

The marker bar is the area where you can place, name, and position markers and regions along the project's timeline. These informational tags can serve as cues or reminders highlighting important events in your project. *For more information, see [Adding project markers and regions](#) on page 78.*

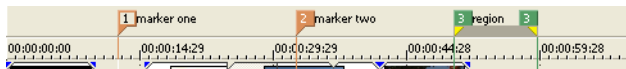

Command bar

The command bar displays when you add a command to your project. Commands add metadata to media files to create effects such as closed captioning. *For more information, see [Adding project markers and regions](#) on page 78.*

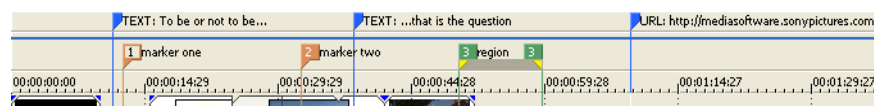

CD layout bar

The CD layout bar displays tracks and indices in an audio CD layout project for disc-at-once (DAO) CD burning. For more information, see [Burning CDs on page 305](#).

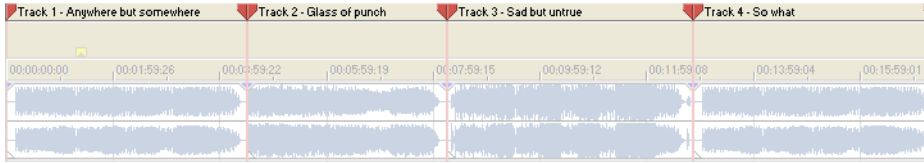

Track list

This area identifies the track order in your project and contains controls used to determine track compositing and mixing. For more information, see [Using the track list on page 52](#).

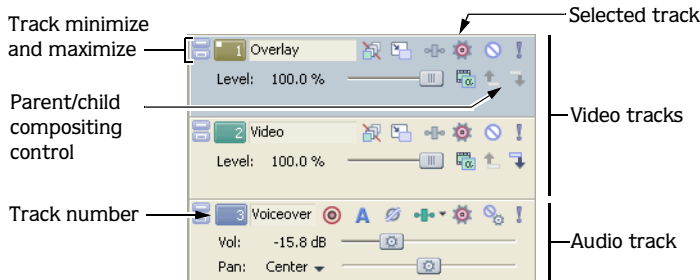

Timeline

All arranging and editing is done in the timeline or track view. This area contains all of a project's events. For more information, see [Using the track view on page 50](#).

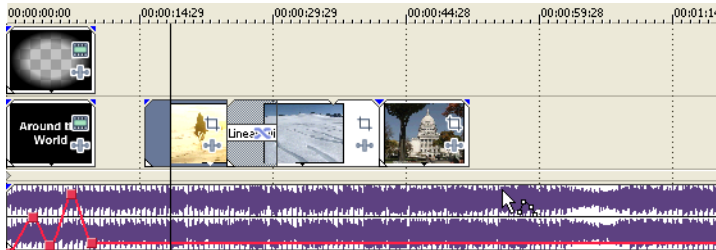

Transport bar controls

The transport bar contains the playback and cursor positioning buttons frequently used while working on and previewing your project.



Status bar

The status bar is located at the bottom of the main program window and displays information about roughly how much space is left on your computer to record audio (Record Time). During the rendering processes, the left side of the status bar also contains information about the progress of the render.

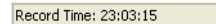

The Video Preview window also has its own status bar that displays project specific information. For more information, see [Understanding the Video Preview window](#) on page 253.

Scrub control

The scrub control is used to play your project forward or backward for editing purposes. You may adjust playback speed by setting the speed control marker located beneath the scrub control. For more information, see [Scrubbing](#) on page 55.

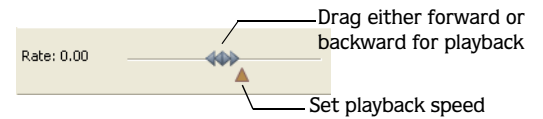

Window docking area and floating window docks

This area allows you to keep frequently used windows available but out of the way while you are working with a project. Windows can be docked next to each other, subdividing the docking area, or they can be docked in a stack in the window docking area or in a separate floating docking window. When stacked, each window has a tab at the bottom with its name on it. Click the window's tab to bring it to the top.

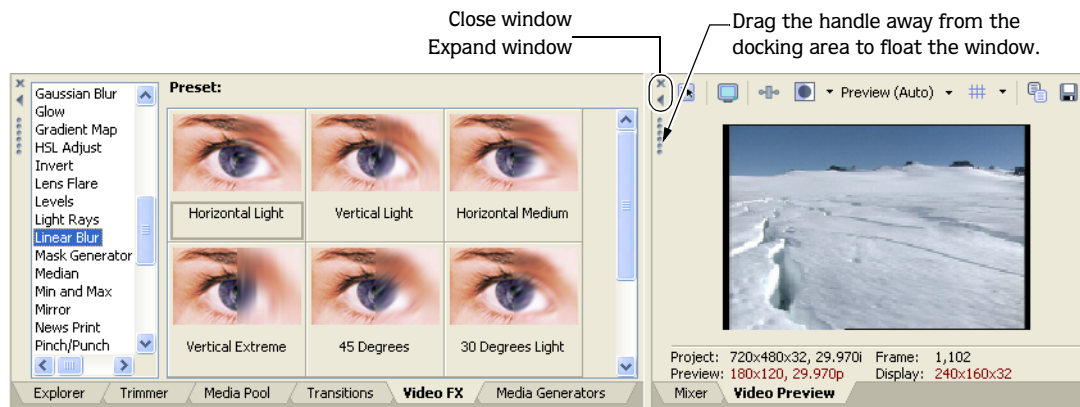

- To dock a window, drag it to the docking area.
- Drag the handle on the left side of a docked window to remove a window from the docking area and float it.
- To prevent a window from docking when you drag it, hold the **Ctrl** key.
- To expand a docked window so it fills the docking area, click the **Maximize** button (☐). Click again to restore the window to its previous size.
- To remove a window from the docking area or a floating dock, click the **Close** button (✕).

Explorer window - Alt+1

The Explorer window is similar to the Microsoft Windows Explorer. Use the Explorer window to select media files to drag to the project timeline or add to the Media Pool. You can also use the Explorer to perform common file management tasks such as creating folders, renaming files and folders, deleting files and folders. Use the Start Preview (▶) and Auto Preview (🔍) buttons to preview files before adding them to the project.

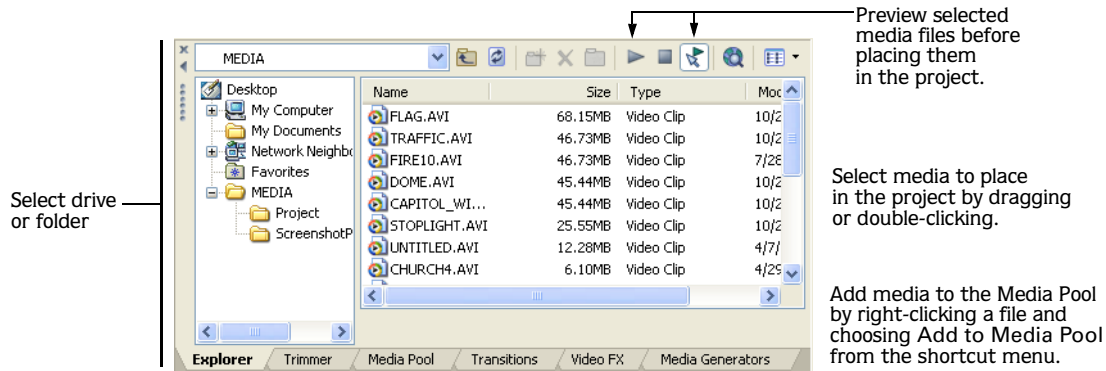

Trimmer window - Alt+2

The Trimmer window is a good place to edit any media file. When a media file is placed in the Trimmer window, you can place portions of the file on separate tracks by dragging and dropping. *For more information, see [Using the Trimmer window](#) on page 96.*

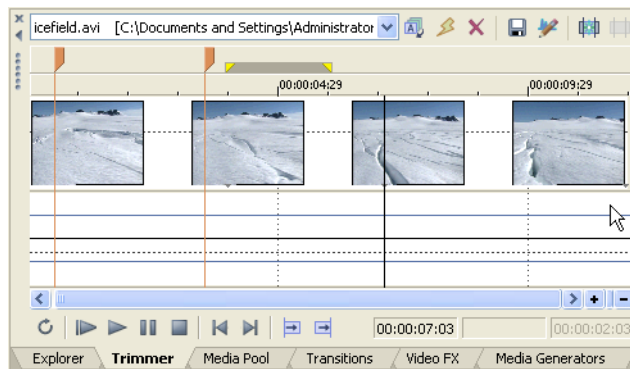

Mixer window - Alt+3

The Mixer window gives you access to your project's audio properties, bus assignments, output levels, and plug-in chains. *For more information, see [Using the Mixer window](#) on page 143.*

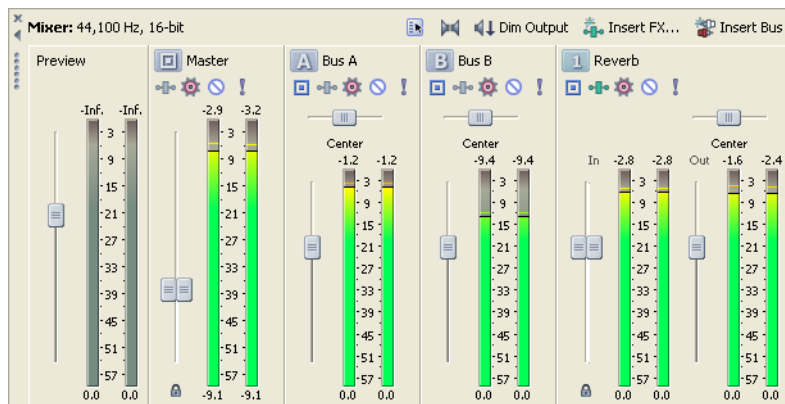

Video Preview window - Alt+4

This window displays a project's video during project editing and playback. For more information, see [Previewing and Analyzing Video on page 253](#).

Video appears during project playback or as the cursor is moved during editing.

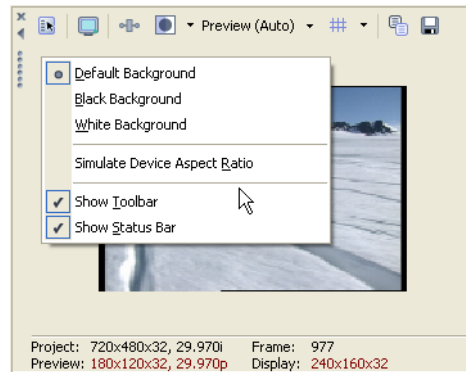

Right-click to change Video Preview settings

Media Pool - Alt +5

The Media Pool helps you organize the media files you're using in a project. The information about these files is displayed in a highly flexible database that can be instantly sorted. You can also use the Media Pool to apply effects and plug-ins to media files and set the specific properties of these files. For more information, see [Using the Media Pool on page 41](#).

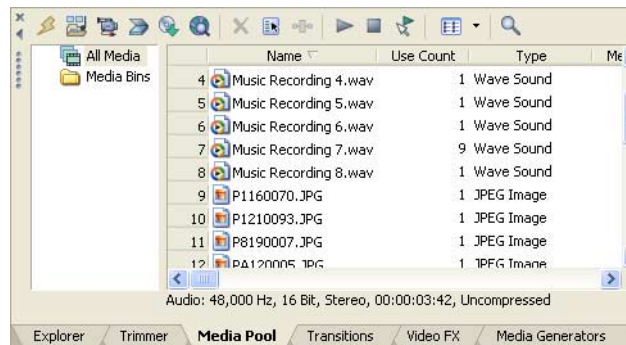

Edit Details window - Alt+6

This window serves as a highly detailed and customizable database of all of the events in a project. The database can be organized and sorted according to a large number of attributes. *For more information, see [Using the Edit Details window](#) on page 101.*



Track	Start	End	Length	Number of Takes	Active Take Name	Take Start	Timecode In	Timecode Out	Tape Name	Select	Mute
1	00:00:00:00	00:00:10:00	00:00:10:00	1	Text 2	00:00:00:00	00:00:00:00	00:00:10:00		<input type="checkbox"/>	<input type="checkbox"/>
2	00:00:15:39	00:00:30:35	00:00:14:71	1	horse8	00:00:00:00	00:00:00:00	00:00:14:71		<input type="checkbox"/>	<input type="checkbox"/>
3	00:00:24:62	00:00:42:01	00:00:17:14	1	icefield	00:00:00:00	00:00:00:00	00:00:17:14		<input type="checkbox"/>	<input type="checkbox"/>
4	00:00:42:01	00:00:52:01	00:00:10:00	1	capitol with people	00:00:00:00	00:00:00:00	00:00:10:00		<input type="checkbox"/>	<input type="checkbox"/>
5	00:01:39:27	00:01:52:07	00:00:12:55	1	kayak2	00:00:00:00	00:00:00:00	00:00:12:55		<input type="checkbox"/>	<input type="checkbox"/>
6	00:00:00:00	00:00:00:00	00:00:00:00	3	Music Recording 6	00:00:00:00	00:00:00:00	00:00:00:00		<input type="checkbox"/>	<input type="checkbox"/>
7	00:00:04:25	00:00:15:11	00:00:10:61	1	Music Recording 7	00:00:04:25	00:00:04:25	00:00:15:11		<input type="checkbox"/>	<input type="checkbox"/>
8	00:01:24:31	00:01:28:06	00:00:03:50	1	Music Recording 2	00:00:00:00	00:00:00:00	00:00:03:50		<input type="checkbox"/>	<input checked="" type="checkbox"/>

Transitions window - Alt+7

The Transitions window contains all of the transitions available. The thumbnails display animated examples of each transition. You can drag transitions from this window to replace the crossfade between two video events or to replace the fade-in or fade-out region of a video event. *For more information, see [Understanding basic transitions](#) on page 231.*

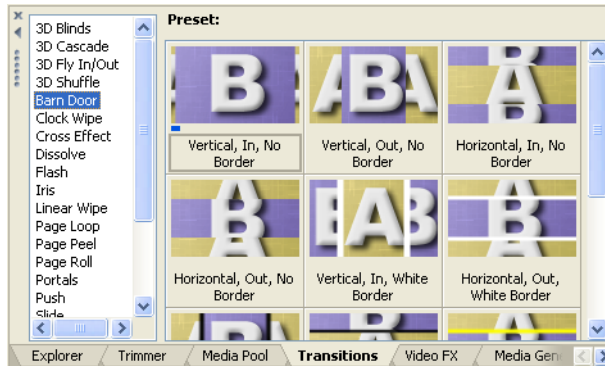

Video FX window - Alt+8

The Video FX window contains the video effects available. The thumbnails display animated examples of each plug-in preset. You can drag plug-ins from this window to an event, track, or to the Video Preview window (video output effects). *For more information, see [Using video effects](#) on page 205.*

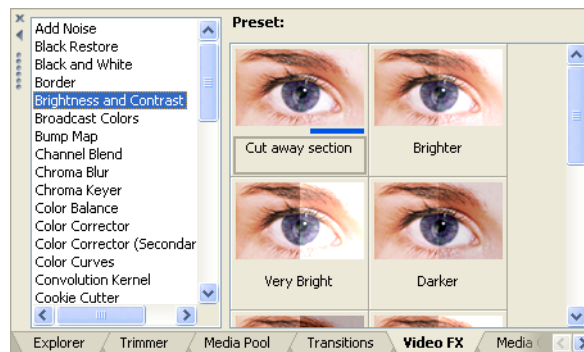

Media Generators window - Alt+9

The Media Generators window contains the different media generators provided. Media generators make it easy to create events containing text, credit rolls, test patterns, color gradients, and solid color backgrounds. You can drag a media generator to the timeline to create a new generated media event. *For more information, see [Using generated media](#) on page 211.*

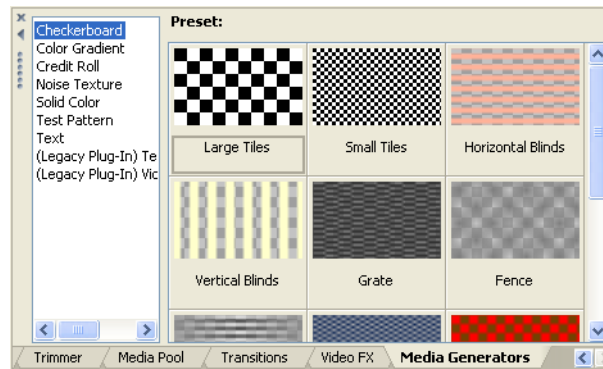

Plug-In Manager- Ctrl+Alt+1

This window organizes all of the plug-ins available, including video and audio effects, media generators, and transitions. The plug-ins, which are organized in a folder structure, can be dragged into the project. *For more information, see [Using audio effects](#) on page 153 or [Using video effects](#) on page 205.*

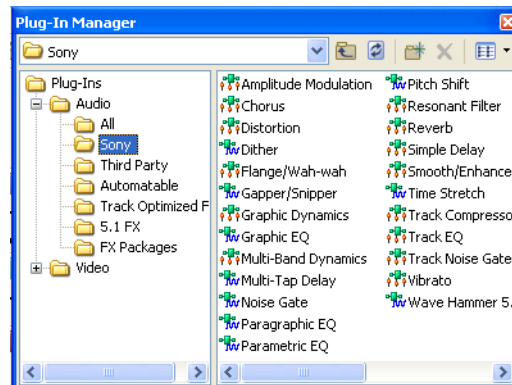

Saving and recalling window layouts - Ctrl+Alt+D or Ctrl+D

A window layout stores the sizes and positions of all windows and floating window docks in the Vegas workspace. You can store up to ten window layouts so you can quickly recall customized layouts for specific editing tasks.

Saving a window layout

1. Arrange the windows and docked windows as desired.
2. Press Ctrl+Alt+D, and then release the keys.
3. Press a number on your keyboard (not the numeric keypad) to save the layout in that space.

Recalling a saved layout

1. Press Alt+D, and then release the keys.
2. Press a number on your keyboard (not the numeric keypad) to recall the layout saved in that in that space.

Keyboard command reference

Project file commands

Description	Keys
Create new project	Ctrl+N
Create new project and bypass Project Properties dialog	Ctrl+Shift+N
Open existing project or media file	Ctrl+O
Save project	Ctrl+S
Open project's properties	Alt+Enter
Close current project	Ctrl+F4
Exit Vegas software	Alt+F4

Window view commands

Description	Keys	Description	Keys
Focus to track view	Alt+0	Media Generators (show/hide window if not docked)	Alt+9
Explorer (show/hide window if not docked)	Alt+1	Plug-ins (show/hide window if not docked)	Ctrl+Alt+1
Trimmer (show/hide window if not docked)	Alt+2	Video Scopes (show/hide window if not docked; available only in the full version of Vegas software)	Ctrl+Alt+2
Mixer (show/hide window if not docked)	Alt+3	Surround Panner (show/hide window if not docked)	Ctrl+Alt+3
Video Preview (show/hide window if not docked)	Alt+4	Next window	F6 or Ctrl+Tab
Media Pool (show/hide window if not docked)	Alt+5	Previous window	Shift+F6 or Ctrl+Shift+Tab
Edit Details (show/hide window if not docked)	Alt+6	Toggle focus between track list and timeline (and bus track list and timeline if bus tracks are visible)	Tab
Transitions (show/hide window if not docked)	Alt+7	Show/hide audio bus tracks (available only in the full version of Vegas software)	B
Video FX (show/hide window if not docked)	Alt+8	Show/hide video bus track (available only in the full version of Vegas software)	Ctrl+Shift+B

Playback, recording, and preview commands

Description	Keys	Description	Keys
Start/stop playback	Spacebar	Scrub playback	J/K/L (pg. 56)
Play from start	Shift+Spacebar or Shift+F12	Build dynamic RAM preview	Shift+B (pg. 256)
Stop playback	Esc	Preview in player	Ctrl+Shift+M
Looped playback mode	Q or Ctrl+Shift+L	Prerender video	Shift+M
Play/pause	Enter or Ctrl+F12	Generate MIDI timecode	F7
Record	Ctrl+R	Generate MIDI clock	Shift+F7
Arm track for record	Ctrl+Alt+R	Trigger from MIDI timecode	Ctrl+F7
Arm for record and set recording path	Ctrl+Alt+ Shift+R	Preview cursor position	Numeric keypad 0
Play back from any window	Ctrl+Spacebar or F12	Specify the length of time that will play using the Cursor preview duration field on the Editing tab of the Preferences dialog.	

Edit commands

Description	Keys
Undo	Ctrl+Z or Alt+Backspace
Redo	Ctrl+Shift+Z or Ctrl+Y
Cut selection	Ctrl+X or Shift+Delete
Copy selection	Ctrl+C or Ctrl+Insert
Paste	Ctrl+V or Shift+Insert
Paste repeat	Ctrl+B
Paste insert	Ctrl+Shift+V

Description	Keys
Delete selection	Delete
Split event(s)	S
Trim/crop selected events	Ctrl+T
Normal Edit Tool	Ctrl+D
Switch to next editing tool	D
Switch to previous editing tool	Shift+D
Open in audio editor	Ctrl+E

Cursor placement commands

Description	Keys
Go to beginning of selection or view (if no selection)	Home
Go to end of selection or view (if no selection)	End
Go to beginning of project	Ctrl+Home or W
Go to end of project	Ctrl+End or E
Move left by grid marks	Page Up
Move right by grid marks	Page Down
Go to	Ctrl+G
Jump to Marker #	0-9 keys (not numeric keypad)
Move one frame	Alt+Left or Right Arrow
Center in View	\
Jog left/right (when not in edge-trimming mode or during playback)	F3/F9

Description	Keys
Move left to marker(s)	Ctrl+Left Arrow
Move right to marker(s)	Ctrl+Right Arrow
Move left to event edit points including fade edges	Ctrl+Alt+Left Arrow
Move right to event edit points including fade edges	Ctrl+Alt+Right Arrow
Nudge cursor one pixel on timeline (when Quantize to Frames is turned off)	Left or Right Arrow
Jump to next audio CD track region or index	Period
Jump to previous audio CD track region or index	Comma
Jump to next audio CD track region	Ctrl+Period
Jump to previous audio CD track region	Ctrl+Comma

Time selection commands

Note: Many of the preceding cursor placement commands, when combined with the Shift key, are also selection commands.

Description	Keys
Snap select to event edge	Ctrl+Shift+Alt+Left or Right Arrow
Select loop region	Shift+Q
Recover previous 5 selection areas	Backspace
Select left by grid marks	Shift+Page Up
Select right by grid marks	Shift+Page Down
Mark in/out locations	I (in) and O (out)
Create time selection while dragging on an event	Ctrl+Shift+drag with mouse
Expand selection one frame	Shift+Alt+Left or Right Arrow
Select to next audio CD track marker	Shift+. (period)
Select to previous audio CD track marker	Shift+, (comma)
Enter location for end of selection	Ctrl+Shift+G

View commands

Description	Keys
Increase track height	Ctrl+Shift+Up Arrow
Decrease track height	Ctrl+Shift+Down Arrow
Minimize all tracks	`
Set track height smaller	Shift+`
Set track heights to default size	Ctrl+`
Zoom in time (incremental)	Up Arrow
Zoom in time until each video thumbnail represents one frame	Alt+Up Arrow
Zoom out time (incremental)	Down Arrow
Zoom in on audio waveforms	Shift+Up Arrow

Description	Keys
Zoom out on audio waveforms	Shift+Down Arrow
Zoom in	Ctrl+Up Arrow
Zoom out	Ctrl+Down Arrow
Show/hide window docking area	F11 or Alt+`
Show/hide track list	Shift+F11 or Shift+Alt+`
Show/hide window docking area and track list	Ctrl+F11
Recall window layout	Alt+D, then press 0-9
Save window layout	Ctrl+Alt+D, then press 0-9
Show/hide envelopes	Ctrl+Shift+E

Event commands

Description	Keys
Move or trim selected event(s) left/right one pixel	Numeric keypad 4/6
Move or trim selected events one frame left/right	Numeric keypad 1/3
Move selected event(s) left/right on grid	Ctrl+numeric keypad 4/6
Move selected event(s) left/right by the project frame period	Alt+Right Arrow numeric keypad 4/6
Move selected event(s) left/right by the first selected event's length	Ctrl+Alt+Right Arrow numeric keypad 4/6
Move selected event(s) up/down one track	Numeric keypad 8/2

Description	Keys
Enter edge-trimming mode and select event start; move to previous event edge [Numeric keypad 7 or
In this mode, 1, 3, 4, and 6 on the numeric keypad trim the selected event edge	
Enter edge-trimming mode and select event end; move to next event edge]	Numeric keypad 9 or
In this mode, 1, 3, 4, and 6 on the numeric keypad trim the selected event edge	
Trim left/right (when in edge-trimming mode)	F3/F9
Exit edge-trimming mode	Numeric keypad 5
Select next take	T
Select previous take	Shift+T

Event editing commands

Description	Keys	Description	Keys
Slip: move media within event without moving the event	Alt+drag inside the event	Raise pitch one semitone	= (not numeric keypad)
Slip Trim: move the media with the edge as it is trimmed	Alt+drag edge of event	Raise pitch one cent	Ctrl+=
Slide: trim both ends of event simultaneously	Ctrl+Alt+drag middle of event	Raise pitch one octave	Shift+=
Slide Crossfade: move crossfade	Ctrl+Alt+drag over a crossfade	Lower pitch one semitone	- (not numeric keypad)
Trim Adjacent: trim selected event and adjacent event simultaneously	Ctrl+Alt+drag edge of event	Lower pitch one cent	Ctrl+-
Stretch (compress) the media in the event while trimming	Ctrl+drag edge of event	Lower pitch one octave	Shift+-
Open in audio editor	Ctrl+E	Reset pitch	Ctrl+Shift+= or Ctrl+Shift+-

Event selection commands

Description	Keys
Range selection	Shift+click range of objects
Multiple selection	Ctrl+click individual objects
Select all	Ctrl+A
Unselect all	Ctrl+Shift+A
Select all events in group	Shift+G

Track commands

Description	Keys
New audio track	Ctrl+Q
New video track	Ctrl+Shift+Q
Enable/disable snapping	F8
Quantize to frames	Alt+F8
Snap to markers	Shift+F8
Snap to grid	Ctrl+F8
Ripple edit mode	Ctrl+L
Auto crossfade mode	Ctrl+Shift+X
Normal edit tool	Ctrl+D
Next tool	D
Previous tool	Shift+D
Mix to new track	Ctrl+M
Change the track that has focus	Alt+Shift+Up/Down Arrow
Mute selected tracks	Z
Mute selected tracks and remove other tracks from mute group	Shift+Z
Solo selected tracks	X
Solo selected track and remove other tracks from solo group	Shift+X
Change audio track volume or video track compositing level (when focus is on track list)	Right/Left Arrow
Change audio track panning or video track fade-to-color setting (when focus is on track list)	Shift+Left/Right Arrow
Override snapping	Shift+drag
Bypass snapping	Shift+drag
Post-edit ripple affected tracks	F

Description	Keys
Post-edit ripple affected tracks, bus tracks, markers, and regions	Ctrl+F
Post-edit ripple all tracks, markers, and regions	Ctrl+Shift+F
Group selected events	G
Remove event(s) from group	U
Clear group (without deleting events)	Ctrl+U
Insert/show/hide track volume envelope	V
Remove track volume envelope	Shift+V
Insert/show/hide track panning envelope	P
Remove track panning envelope	Shift+P
Make fine envelope point or segment adjustments without changing envelope points' timeline positions	Ctrl+drag envelope point or segment
Make normal envelope point or segment adjustments without changing envelope points' timeline positions	Ctrl+Alt+drag envelope point or segment
Adjust envelope point's timeline position without changing its value	Alt+drag
Insert region	R
Insert marker	M
Insert command marker	C
Insert audio CD track region	N
Insert audio CD track index	Shift+N
Insert transition	/, *, - (numeric keypad)
Insert cut transition	Ctrl+*, - (numeric keypad)
Convert crossfade or transition to cut	Ctrl+/ (numeric keypad)
Cycle through effect automation envelopes	E or Shift+E

Trimmer commands

Tip: Many of the shortcuts that apply to the timeline (e.g., cursor placement, selection commands, etc.) also work in the Trimmer.

Description	Keys
Add Media From Cursor	A
Add Media to Cursor	Shift+A
Transfer time selection from timeline to Trimmer after cursor	T
Transfer time selection from timeline to Trimmer before cursor	Shift+T
Toggle selected stream: audio/video/both	Tab



Description	Keys
Toggle audio/video stream height	Ctrl+Shift+Up/Down Arrow
Sort Trimmer history	H
Clear Trimmer history	Ctrl+Shift+H
Save markers/regions	S
Open in audio editor	Ctrl+E

Track Motion window shortcuts

Description	Keys
Change 3D layout	1-6 (not numeric keypad)
Lock aspect ratio	A
Scale about center	C
Edit in object space	O
Prevent movement	X, Y, and Z
Prevent scaling	Shift+X, Shift+Y, and Shift+Z
Enable snapping	F8
Enable rotation	Shift+F8

Surround panner commands

For finer, more precise movements on the shortcuts in this section, add the **Ctrl** key.

Description	Keys
Constrain motion to a line through the center of the surround panner	Shift+drag the pan point (only when Move Freely  is selected)
Constrain motion to a constant radius from the center	Alt+drag the pan point (only when Move Freely  is selected) or Alt+mouse wheel
Constrain motion to the maximum circle that will fit in the Surround Panner	Alt+Shift+drag the pan point (only when Move Freely  is selected) or Alt+Shift+mouse wheel
Move the pan point forward/back (when the pan point is selected)	Up/down arrow or Page Up/Page Down or mouse wheel
Move the pan point left/right (when the pan point is selected)	Left/Right Arrow or Shift+Page Up/Page Down or Shift + mouse wheel forward/back
Move the pan point to a corner, edge, or center of the Surround Panner (when the pan point is selected)	Numeric Keypad
Move the pan point to a corner on the largest circle that will fit in the Surround Panner (when the pan point is selected)	Ctrl+Numeric Keypad 1,3,7,9

Miscellaneous commands

Description	Keys
Online help	F1
What's This? help	Shift+F1
Change relative keyframe spacing	Alt+drag keyframes
Make fine fader/slider adjustments	Ctrl+drag fader/slider

Description	Keys
Shortcut menu	Shift+F10
Rebuild audio peaks	F5
Move both region markers or audio CD track region markers	Alt+drag region marker

Multimedia keyboard shortcuts









Description	Keys
Play/Pause	Play/Pause
Play from start	Shift+Play/Pause
Stop	Stop
Mute track	Mute
Mute track and remove other tracks from mute group	Shift+Mute
Solo track	Ctrl+Mute
Solo track and remove other tracks from solo group	Ctrl+Shift+Mute
Change audio track volume or video track compositing level (when focus is on track list)	Volume Up/Down
Change audio track panning or video track fade-to-color setting (when focus is on track list)	Shift+Volume Up/Down
Change track focus	Next/Prev Track

Mouse wheel shortcuts

Description	Keys
Zoom in/out on timeline	Default mouse wheel behavior
Zoom in/out in Event Pan/Crop or Track Motion windows	Default mouse wheel behavior
Vertical scroll	Ctrl+wheel
Horizontal scroll	Shift+wheel
Move the cursor in small increments	Ctrl+Shift+wheel
Move cursor one frame at a time	Ctrl+Shift+Alt+wheel
Auto-scroll	Press mouse wheel and move mouse left or right
Move fader/slider	Hover over fader and use wheel
Move fader/slider with fine control	Ctrl+hover over fader and use wheel

Cursor indications

The cursor changes depending on which functions are available.

Cursor	Indicates	Modifier	Description
	Standard	none	This is the standard arrow cursor that means events can be dragged.
	Trim	none	Position the cursor over the edge of an event and drag to trim the event shorter or longer.
	Slip Trim	Alt	Position the cursor over the edge of an event, press Alt, and drag to trim. The media within the event moves with the edge. This is useful to preserve the beginning or end of an event while trimming.
	Stretch	Ctrl	Position the cursor over the edge of an event, press Ctrl, and drag the edge to stretch or compress it. This makes the media in the event play slower or faster.
	Slip	Alt	Press Alt and drag on the middle of a clip to move the media within the event without moving the event itself.
	Trim Adjacent	Ctrl+Alt	Position the cursor over the boundary between two adjacent events, press Ctrl+Alt, and drag. Both events are edge trimmed simultaneously.
	Slide	Ctrl+Alt	Position the cursor over the middle of an event, press Ctrl+Alt, and drag to simultaneously trim both ends.
	Slide Crossfade	Ctrl+Alt	Position cursor over a crossfade, press Ctrl+Alt, and drag on a crossfade to move it.

Using a control surface

A control surface is a hardware device that uses knobs, faders, and buttons to control user interface elements that are normally controlled with a mouse. Using a control surface lends a tactile feel to your editing sessions.

Unlike keyboard shortcuts—which determine the shortcut's behavior based on the portion of the Vegas window that has focus—a control surface's mapped functions work no matter what part of the application has focus.

You can use one Mackie® Control Universal or up to five generic control surfaces with Vegas software. For more information about setting up a control surface, please see [External Control & Automation tab on page 303](#).

Audio signal flow

 Multiple audio busses and assignable effects are only available in the full version of Vegas software.

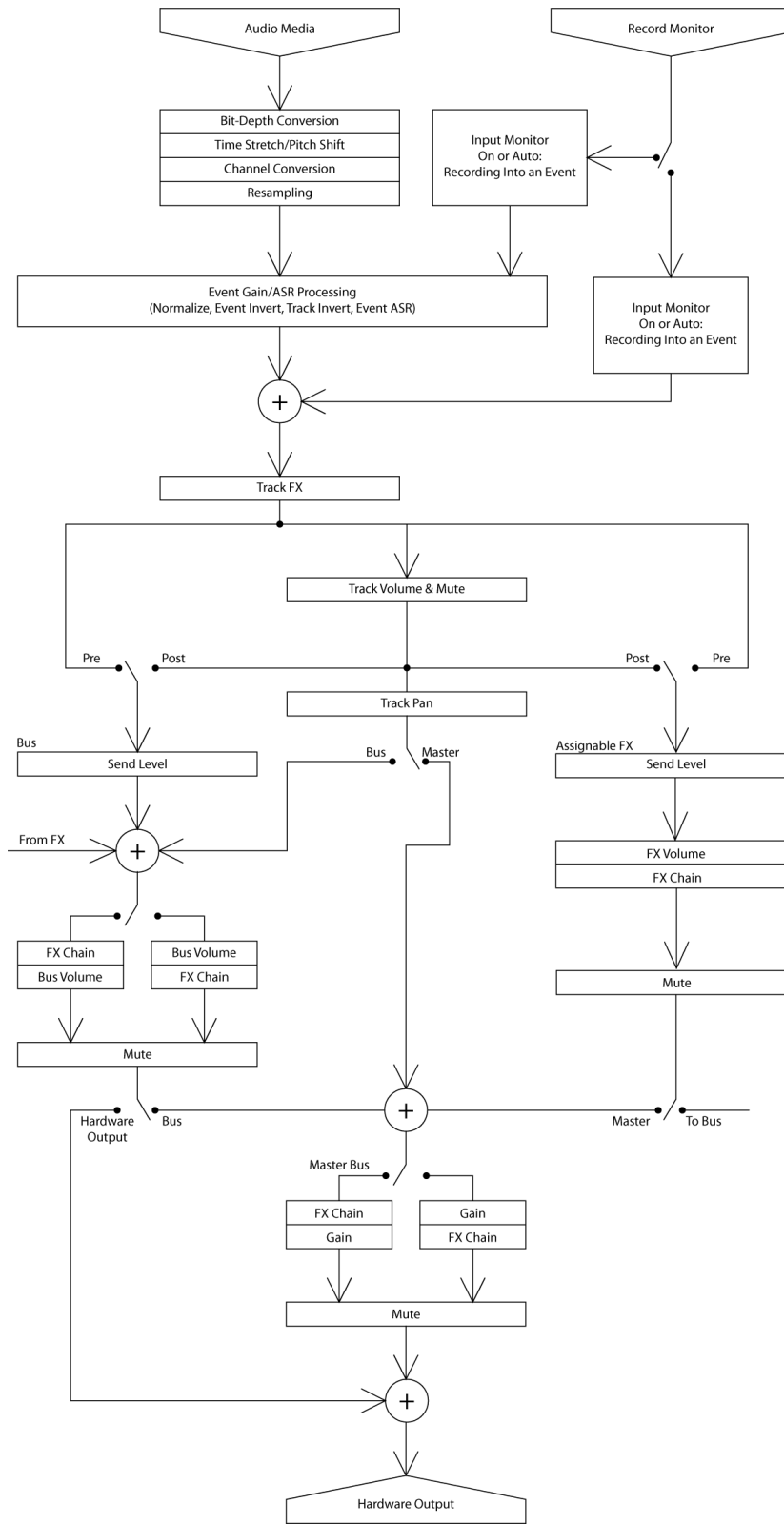

Video signal flow

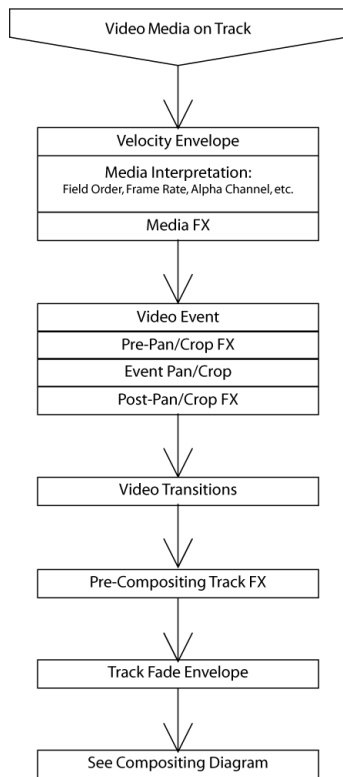

Track signal flow

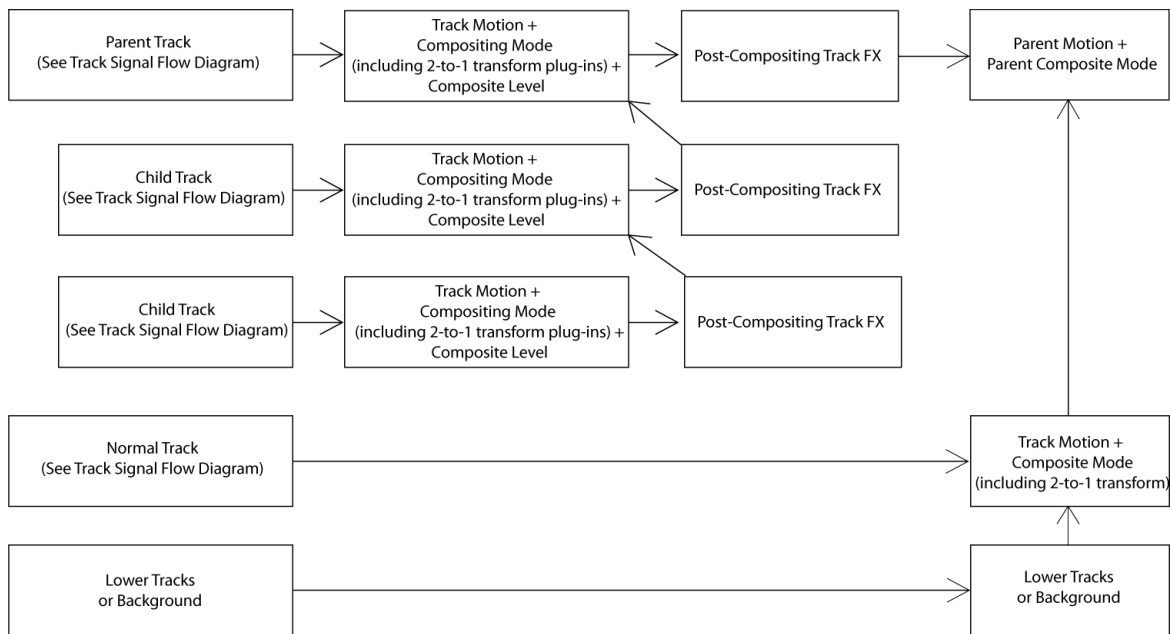

Composited track signal flow

About your rights in Vegas software

Vegas software is licensed to you under the terms of the End User License Agreement. The End User License Agreement is first presented to you when you install the software. Please review the End User License Agreement carefully as its terms affect your rights with respect to the software. For your reference, a copy of the End User License Agreement for Vegas software is located at <http://www.sony.com/mediasoftware>.

About Your Privacy

Sony Pictures Digital respects your privacy and are committed to protecting personal information. Your use of the software is governed by the Software Privacy Policy. A copy of this policy is incorporated into the registration process and you are asked to agree to its terms prior to accepting the terms of the End User License Agreement. Please review its contents carefully as its terms and conditions affect your rights with respect to the information that is collected by the software. For your reference, a copy of the Software Privacy Policy is located at <http://www.sony.com/mediasoftware>.

Proper Use of Software

The Vegas software is not intended, and should not be used for, illegal or infringing purposes, such as the illegal copying or sharing of copyrighted materials. Using Vegas software for such purposes is, among other things, against United States and international copyright laws and contrary to the terms and conditions of the End User License Agreement. Such activity may be punishable by law and may also subject you to the breach remedies set forth in the End User License Agreement.

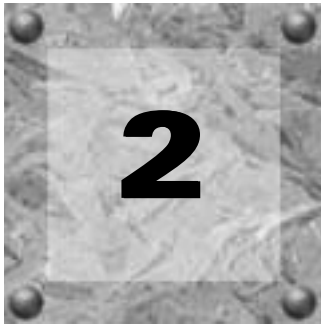

Getting Started

Vegas® software is a new way of creating multimedia productions. Whether you are an experienced multimedia author or a budding novice, the powerful features and capabilities of Vegas software are organized to increase your creativity and productivity. The following chapter summarizes the software's basic functions and operations.

Creating projects

The process of creating a multimedia production can be a complicated undertaking, involving hundreds of shots, takes, voiceovers, music beds, audio tracks, and special effects. Organization is a critical issue in this process. In the software, organization is handled by a small project file (VEG) that saves information about source file locations, edits, cuts, insertion points, transitions, and special effects. This project file is not a multimedia file, but is instead used to create (render) the final file when editing is finished.

Because Vegas software edits a *project* file and not the original source files, you can edit without worrying about corrupting your source files. This not only gives you a strong sense of security, but it also gives you the freedom to experiment.

1. From the **File** menu, choose **New**. The New Project dialog appears.

Note: *The first time you run the software, a new project will automatically be started for you.*

2. Enter your project settings on the various tabs. *For more information, see [Working with project properties](#) on page 291.*

- The Video tab allows you to select the video format and other video parameters.
- The Audio tab allows you to set up the basic audio settings.
- The Ruler tab allows you to choose the way the ruler is delineated (beats, seconds, etc.).
- The Summary tab allows you to enter any relevant information and reminders about your project.
- The Audio CD tab allows you to enter information for burning audio CDs.

Tip: *The easiest way to set the often-complex properties on the Video tab is to select a template that matches your media (e.g., NTSC DV (720x480, 29.970 fps)).*

3. Click OK.

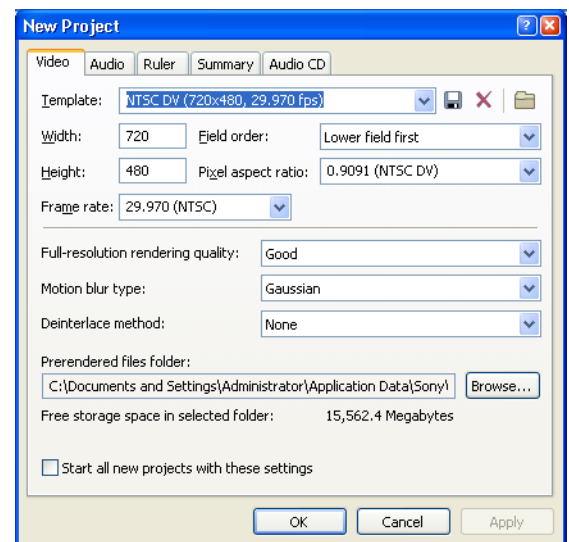

- From the **File** menu, choose **Save**. Enter a name, browse for a location, and click Save to save your project (VEG file).

You can change project settings at any time while working on a project. From the **File** menu, choose **Properties** to change any of these settings.

Setting video properties based on a media file

You can automatically set your project video properties to match an existing video file.

- From the **File** menu, choose **Properties**.
- On the Video tab of the Project Properties dialog, click the Match Media Settings button ().
- Browse for a media file that has the settings you wish you use for the project.
- Click Open.

The frame size, frame rate, pixel aspect ratio, and field order of this file are automatically detected and the project properties are set to match.

Tip: To save this information for future use, enter a name in the Template box and click the Save Template button (). If your projects typically use these settings, select the Start all new projects with these settings check box.

- Click OK to save the new project properties.

Saving a project

When you save your work, it is saved in a project file. Project files are not rendered media files.

- From the **File** menu, choose **Save**.

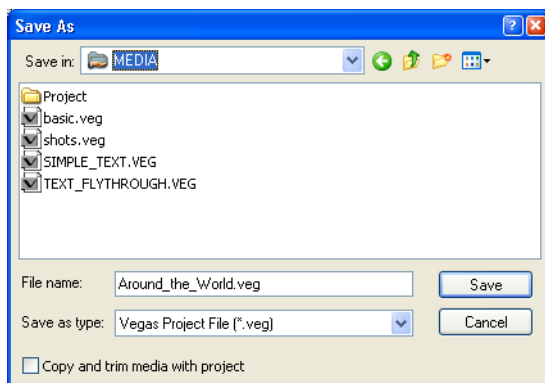

The first time you save a project, the Save As dialog appears. In subsequent saves, the dialog is bypassed, your existing file name is retained, and your project is updated to include any implemented changes.

- Select the drive and folder where you want to store the project.
- Type the project name in the File Name box.

4. Click Save.

Tip: Select the Copy and trim media with project check box to save the project file and copies of the media files to a common location. For more information, see [Saving a project with media](#) on page 270.

Renaming a project (using Save As)

After you have been working with your project, you can use the **Save As** command in the **File** menu to save a copy of a project with a new name. This is useful for backing up different versions of a project. For more information, see [Creating a copy of a project \(using Save As...\)](#) on page 270.

Getting media files

You can add media from a variety of sources to your project. You can add audio and video files, record audio into a track, capture video from a video camera, or extract music from your own CD. You can also create media such as text overlays, backgrounds, and credit rolls from within the software. For more information, see [Using generated media](#) on page 211.

Note: To have pulldown fields automatically removed when opening 24 fps progressive-scan DV video files, select the Allow pulldown removal when opening 24p DV check box on the General tab of the Preferences dialog. To open your 24p DV video files as 29.97 fps interlaced video (60i), clear this check box.



Note: When you add an ACID loop to the timeline, it is automatically stretched to match the project tempo as specified on the Ruler tab of the Project Properties dialog. If you want to ignore tempo information, clear the Import at project tempo check box on the Audio tab of the Preferences dialog. For more information on project properties, see [Working with project properties](#) on page 291. For more information on preferences, see [Setting preferences](#) on page 294.

Selecting media



Vegas software supports a wide range of media file types. You may select any of the media file types listed below to add to your project.

Format	Extension	Definition
GIF	.gif	256 index color, lossless image and animation format widely used on the Internet.
JPEG	.jpg	True color, lossy Internet image format.
Macintosh® Audio Interchange File Format	.aif	Standard audio format developed by Apple® and used on Macintosh® computers.
MPEG-1 and MPEG-2	.mpg	MPEGs, files compressed using a lossy audio/video compression method, can be used with Vegas software.
MPEG Layer 3	.mp3	Highly compressed audio file.
Ogg Vorbis	.ogg	A patent-free audio encoding and streaming technology.
Photoshop	.psd	Adobe® Photoshop® proprietary image format (flattened).
Portable Network Graphic	.png	True color or indexed color, lossy or lossless Internet image format.
QuickTime™	.mov, .qt	QuickTime standard audio/video format.
Perfect Clarity Audio®	.pca	A proprietary lossless audio compression format from Sony Pictures Digital.
Wave 64™	.w64	Sony Pictures Digital proprietary Wave64 audio file that does not have a limited file size (unlike Windows WAV files that are limited to ~2GB).
TARGA	.tga	True color, lossless image format that supports alpha channel transparency.
TIFF	.tif	Tagged Image File Format, a common bitmap format. You must have QuickTime installed to use TIFF files in Vegas software.
Video for Windows®	.avi	Standard audio/video format used on Microsoft® Windows®-based computers.
Wave (Microsoft®)	.wav	Standard audio format used on Microsoft Windows-based computers.
Wave (Scott Studios)	.wav	Standard audio format used with Scott Studios systems.
Windows Bitmap	.bmp	Standard graphic format used on Microsoft Windows-based computers.
Windows Media® Audio	.wma	The Microsoft audio-only format used to create files for streaming or downloading via the Web.
Windows Media Format	.wmv	The Microsoft standard used for streaming audio and video media via the Web.

Previewing a media file

You may preview files before placing them in your project. The Explorer window has a mini-transport bar with Play, Stop, and Auto Preview buttons (  ). When you preview a file, its stream is sent to the Mixer window's preview bus (for audio files) or to the Video Preview window (for video files).

Tip: You can use the same mini-transport bar buttons in the Media Pool window to preview files in the Media Pool.

1. Select a file in the Explorer window.
2. Click the Play button () to listen to the file.
3. Click the Stop button () or select a different file to stop previewing the file.

Tip: To automatically preview selected files, click the Auto Preview button () on the Explorer window's transport bar.

Using the Media Pool

Media files, both video and audio, tend to be the largest files on your hard drive. It is therefore not always easy to move them around and impractical to store multiple copies of these files. You can add media files to the Media Pool to organize them before any editing begins. Once you begin working on a project, all files you add to the timeline are automatically included in the Media Pool. From the **View** menu, choose **Media Pool** to open this window if it is not already visible.

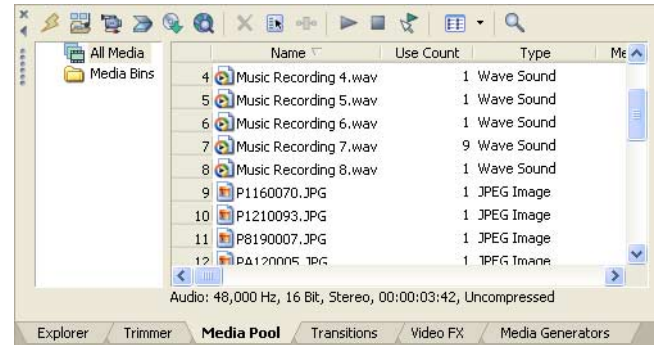

Using Media Pool views

You can control the information that is displayed in the Media Pool by clicking the Views button () and selecting a view.

The **Detailed** view displays all the properties for each file. The information is presented in a table format. You can customize the information displayed:

- Reorder columns (fields) by dragging the column label to a new position.
- Hide a column by dragging the column label off of the Media Pool window. To display a hidden column, right-click the Media Pool, choose **View** from the shortcut menu, and choose the column name from the submenu.
- Sort the files in the Media Pool according to a category by clicking the column label for that category.
- Use the Comments field to add your own annotations to a file's entry in the Media Pool. Double-click the field to enter text. This information is saved with the project and is not saved with the media file itself.

Adding media to the Media Pool

1. Click the Import Media button () in the Media Pool. The Import Media dialog appears.
2. Navigate to and select a media file to add to the Media Pool. You can use **Ctrl** or **Shift** to select multiple files.
3. Click **Open**.

The media file is added to the Media Pool.

Adding media to the Media Pool from the Explorer window

1. Navigate to and select a file to add to the Media Pool. You can use **Ctrl** or **Shift** to select multiple media files.
2. Right-click the file and choose **Add to Media Pool** from the shortcut menu.

The selected file is added to the Media Pool.

Replacing media in the Media Pool

You may replace a file in the Media Pool with a different file. When changing the media file that an event contains, every occurrence of the event on the timeline is updated with the new media file contents.

1. Right-click a file in the Media Pool.
2. Choose **Replace** from the shortcut menu.
3. In the Replace Media File dialog, browse for and select the file that you want to replace the current file.
4. Click **Open**. The selected file replaces the old file in the Media Pool, and any events in the timeline containing the old file are updated to contain the new media file.

Capturing video

You can use the Sony Pictures Digital Video Capture application (installed with Vegas software) to capture video clips from your video camera and add them to the Media Pool window.

Note: *You must have an IEEE-1394/OHCI-compliant video capture card installed to use Video Capture.*

1. If you have not already done so, connect your video camera to your video capture card using the cable provided with the card.
2. In the Media Pool window, click the Open Video Capture button (). The Sony Pictures Digital Video Capture application starts.

Note: *If your video camera is properly connected, the Video Preview window in the center of the application area should display “Device connected.”*

3. Capture your video. For information on capturing video with Sony Pictures Digital Video Capture, choose **Contents and Index** from the **Help** menu within Video Capture to display Video Capture online help.

Once you have captured your video, Video Capture adds the file(s) to the Media Pool window. If any captured clips go offline, you can recapture the clips using Video Capture. Right-click an offline file in the Media Pool and choose **Recapture** from the shortcut menu.

Getting images

You can bring images directly into the software from your scanner, digital camera, or other TWAIN device. The images are added to the Media Pool as JPEG image files.

1. Make sure your device (scanner or digital camera) is on and connected to your computer.
2. In the Media Pool window, click the Get Photo button (). The software is started for the device.
3. Use the device software to get an image and send it to Vegas software. Once the image has been sent, the Scanned Files dialog appears.
 - Click **Rename** to give the new image a more meaningful name.
 - Click **Delete** to cancel the process of adding the image.
4. Click **Done**. The new JPEG file is added to the Media Pool.

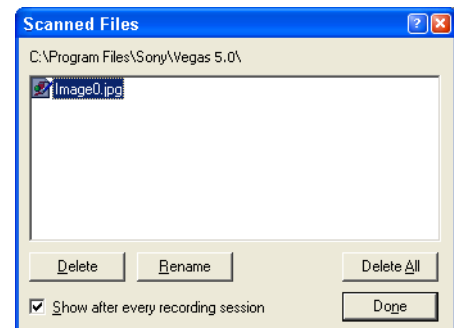

Extracting audio from a CD

You can extract tracks from a CD and add them to the Media Pool window as WAV files.

Vegas software is not intended for, and should not be used for, illegal or infringing purposes, such as the illegal copying or sharing of copyrighted materials. Using Vegas software for such purposes is, among other things, against United States and international copyright laws and contrary to the terms and conditions of the End User License Agreement. Such activity may be punishable by law and may also subject you to the breach remedies set forth in the End User License Agreement.

 CD audio extraction is only available in the full version of Vegas software.

1. Insert the audio CD.
2. In the Media Pool window, click the Extract Audio from CD button (). The Extract Audio from CD dialog appears.
3. From the Action drop-down list, choose the method you want to use for extracting the CD audio:
 - Read by track - Use this option to choose the tracks you want to extract from the CD.
 - Read entire disc - Use this option to automatically extract all tracks on the disc. The entire CD is extracted into one new file in the Media Pool.
 - Read by range - Use this option to extract audio from a specified range of time.
4. If you chose either the Read by track or Read by range option, specify the track(s) or range to extract:
 - For Read by track, click the track(s) you want to extract in the Tracks to read list. Use the **Ctrl** or **Shift** keys to select more than one track. Each track is extracted into a separate file in the Media Pool.
 - For Read by range, enter a time in the Range start field and either the Range end or Range length fields. The range of audio is extracted into one new file in the Media Pool.

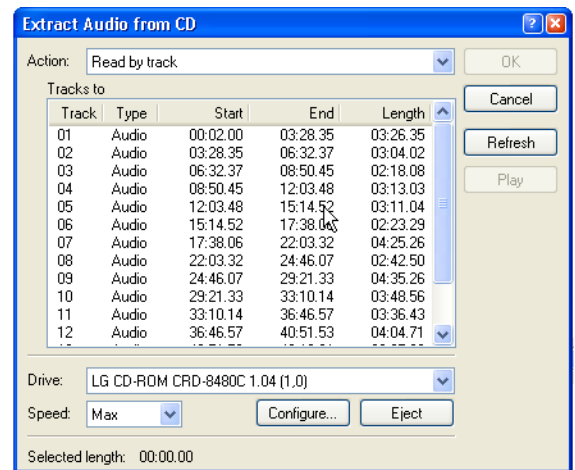

Note: *If you want to extract multiple tracks to a single file, choose Read by track from the Action drop-down list to select your tracks, and then choose Read by range from the Action drop-down list. The appropriate time range for the tracks you selected will automatically be inserted and the time range will be extracted to a single file.*

5. From the Drive drop-down list, choose the drive containing the audio CD from which you want to extract.
6. From the Speed drop-down list, choose the speed at which you want to extract the audio. If you experience any problems extracting audio, you can try decreasing the selected speed, or you can click Configure to adjust the Audio extract optimization setting.

Note: To eject the CD at any time prior to beginning the extraction process, click the Eject button.

7. Click OK. The Save As dialog appears.
8. Select a name and location for the new WAV file.
9. Click Save to begin extracting the audio.

The track is extracted and a progress meter is displayed to indicate the percent complete. Once extraction is complete, the new WAV file appears in the Media Pool.

The option of automatically naming extracted tracks is provided for you. To enable this option, choose **Preferences** from the **Options** menu, and on the CD Settings tab, select the Autaname extracted tracks check box. For more information, see [CD Settings tab](#) on page 300.

Adding a still-image sequence

If you've exported a video clip as a still-image sequence using another application (a 3D-rendering application, for example), the sequence can be added to the Media Pool and treated as a single media file. Each image in the sequence will be displayed for one frame in the event.

1. Click the Import Media button () in the Media Pool window. The Import Media dialog appears.
2. Choose the folder where the sequence you want to open is stored.
3. Select the first image in the sequence (or the image you want to start the event).
4. Select the Open still-image sequence check box.
5. In the Range field, enter the number of the last image you want to open. For example, if you'd selected AnimationOne_00001.tga in step 3, you could enter 120 in this box to create a new image sequence using AnimationOne_00001.tga to AnimationOne_00120.tga.
6. Click Open. The still-image sequence is added to the Media Pool.

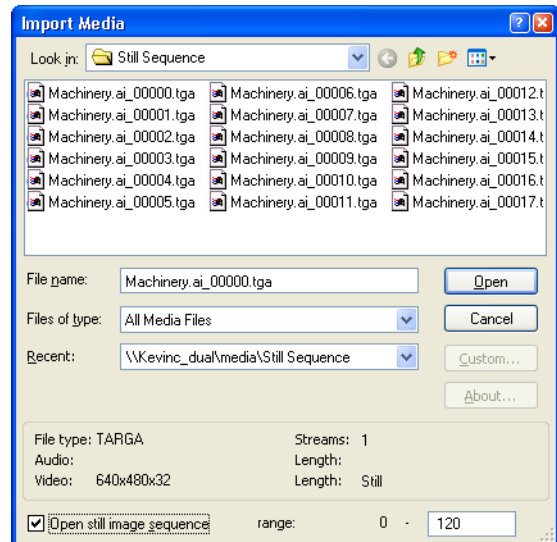

Sorting media with bins

The detailed view of the Media Pool window helps you sort your media files using their attributes, but for more control, you can create bins. Bins are folders within projects that you can use to organize your media files.

Media bins are virtual folders that are saved with your project. They do not affect the way media is saved on your computer.

Creating bins

Right-click the parent bin where you want to create a new bin and choose **Create New Bin** from the shortcut menu.

Adding media to a bin

1. Browse your existing bins to find the media file you want to move. The All Media Folder contains all media files in your project.
2. Drag a file from the right-hand pane to a bin.

Searching media bins

1. Right-click in the Media Pool window and choose **Search Media Bins** from the shortcut menu. The Search Media Bins dialog is displayed.
2. Use the drop-down lists in the Search Media Bins dialog to set your search conditions and click the Search button. The selected bin and all sub-bins will be searched.
3. Click the Search Results icon to view the matching files.

Hint: Right-click the Search Results icon and choose **Save as Bin** from the shortcut menu to save the results of your search as a new media bin.

Automatically adding recorded files to a media bin

Select a media bin if you want to automatically add your recorded audio to a media bin.

Deleting media from a bin

1. Select a media file.
2. Press **Delete** on your keyboard.
3. If the All Media Folder is selected, the file will be removed from your project.
4. If a media bin is selected, the file is removed from the bin, but remains part of your project. The file is still available in the All Media Folder.

Configuring 24p pulldown removal

Right-click a DV AVI file in the Media Pool and choose **File Format Properties** from the shortcut menu to edit file settings from the file format plug-in associated with the media file type.

For 24p NTSC DV AVI files with 2-3 pulldown, you can use this dialog to configure removal of pulldown fields.

In most cases, you will not need to edit pulldown removal settings. However, if the settings were not properly set in the DV header when your video was captured, you can fine-tune pulldown removal without recapturing your video.

1. Right-click an AVI file in the Media Pool and choose **File Format Properties** from the shortcut menu. The AVI/DV Media Properties dialog is displayed.

This command is not available for non-24p NTSC video or for 24p NTSC video using 2-3-3-2 pulldown.

2. Select the Enable 2-3 pulldown removal check box.

You can clear this check box if you want to override pulldown removal for individual files when the Enable pulldown removal when opening 24p DV check box is selected on the General tab of the Preferences dialog.

3. Choose a setting from the Starting frame timecode offset drop-down list to indicate what timecode numbers represent which frame in the video sequence.

For example, if you have an NTSC DV file with 2-3 pulldown created on a Sony JH3 HDCAM deck, the default settings for timecode offset use 0 for the Starting frame timecode offset.

If you have changed the timecode offsets on the deck (or if you have material with pulldown from another source) you will have to experiment with the settings to determine the correct offset.

4. Check for interlacing:
 - a. In the Project Properties dialog, choose a NTSC DV 24p template from the Template drop-down list.
 - b. Choose the **Best (Full)** setting in the Video Preview window to show full frames.
 - c. Step though the clip and look for interlace lines in moving objects or backgrounds.
 - d. If you see interlace lines, repeat from step 3 and choose a different offset value.
 - e. When no interlace lines appear, the offset is set correctly.

Adding media to the timeline

Media files may be added to your project from the Explorer or Media Pool by double-clicking them or by dragging them. Either method places the media file in an event in its entirety in the timeline.

Dragging a media file to the timeline

You can create a new track by dragging a media file to a blank area on the timeline and dropping it in place. Tracks can contain multiple events, so you can place different events next to each other on a track.

Note: Video and audio events cannot be placed on the same track.

1. Locate a media file in the Explorer or Media Pool.
2. Drag the media file to the timeline.

An event for the media file appears where you released the mouse.

Dragging multiple media files to the timeline

1. Select multiple media files in the Explorer or Media Pool. Select a range of adjacent media files by pressing **[Shift]** and clicking the first and last files in the range or select files that are not adjacent by pressing **[Ctrl]** and clicking individual files.
2. Right-click and drag the files to the track view (timeline).
3. When you release the mouse, a shortcut menu appears. Select a placement option from the menu.

- Add Across Time



- Add Across Tracks

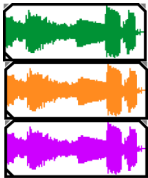

- Add As Takes

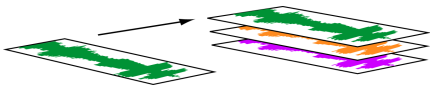

You will see one event on the track. The other events are listed at takes "beneath" the the topmost event.

For more information, see [Working with takes](#) on page 94.

- **Video Only** and **Audio Only** allow you to isolate either the video or audio, and add that stream from a multimedia file either across tracks, across time, or as takes.

Tip: A left-click drag-and-drop automatically inserts files across time. However, you can cycle through placement modes by right-clicking (without releasing the left mouse button) while performing the drag-and-drop operation.

Double-clicking a media file

This method places the event at the cursor's position in the selected track. If the selected track is a video track, and you double-click an audio event (or vice versa), a new track is created for the event. Once an event is placed, you can move it from one track to another or change its position on the timeline.

Inserting a video file with associated audio

Media files with video frequently include associated audio. When you insert a media file into the timeline, the associated audio is automatically inserted into a separate audio track below the video track. The two associated events are grouped together and behave as a single unit when moved or otherwise edited. You can ungroup the events to move them independently. *For more information, see [Clearing a group](#) on page 142.*

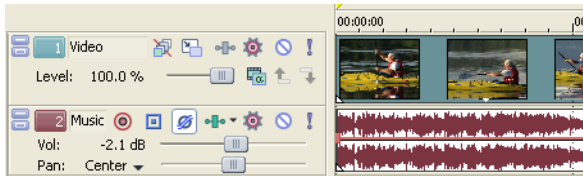

Two events that contain the video (top) and audio (bottom) streams from a single multimedia video file; each event is inserted on a separate track.

Automatically crossfading inserted events

When inserting multiple events across time, the events (both video and audio) may be set to automatically crossfade. Two options must be enabled in order to create crossfades automatically when adding multiple events. First, verify that a check mark appears next to **Automatic Crossfades** in the **Options** menu. Second, from the **Options** menu, choose **Preferences**, and on the Editing tab, select **Automatically overlap multiple selected media when added**. *For more information, see [Using automatic crossfades](#) on page 75.*

Working with events

Events are the most basic objects in a project. An event is something that happens in time, has a specific duration, and can be video or audio.

Understanding files and events

The objects you work with are referred to as media files and events.

- **Files** are objects that are stored on your hard disk. In Vegas software, you will work with media files, such as music and video files. These files are neither operated on nor changed. You can access files from the Vegas Explorer window.
- **Events** are periods of time on the timeline that act as windows into media files, either whole or in part. When you drag a media file onto the timeline, you automatically create an event that contains that file's contents. An event can contain video, audio, still images, or generated media. The event window may contain only a small portion of a much larger media file. A single media file can be used repeatedly to create any number of different events, since each event can be trimmed independently.

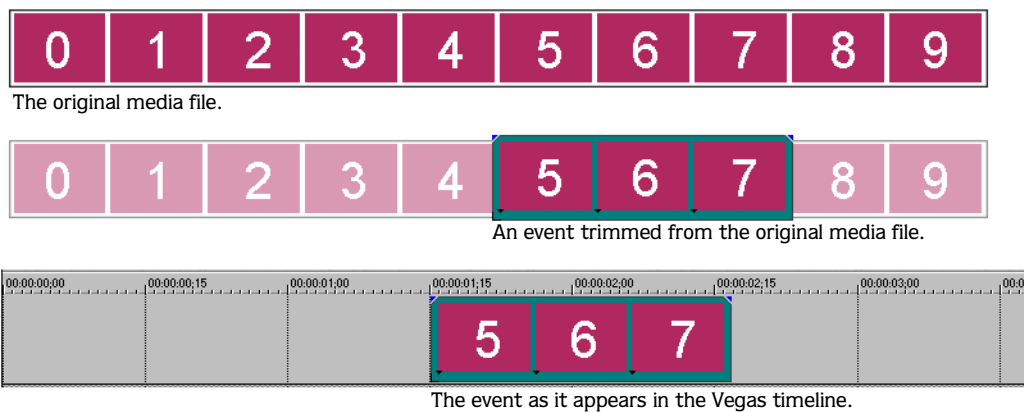

Audio events are created from audio files on your computer (e.g., WAV, MP3) or can be a part of a video file (e.g., AVI). You can change many characteristics of an audio event, such as speed, volume, and equalization. Audio events can be mixed with other audio events.

Video events are created from video files captured to your computer (typically AVI, MOV, QT) or images (BMP, JPEG, PNG, or TGA). You can change many characteristics of a video event, such as speed, color, and size. Video events can overlay other video events and are visual elements that appear on top of a background video, image, or color.

Moving events along the timeline

You can move events along the timeline individually or as a group. Events may overlap each other or be placed on top of each other. You can crossfade overlapping events automatically or with envelopes.

Moving an event

You can move an event along the timeline within a track or move it to a different track.

1. Drag the event along the timeline.

If you move the event along the original track's timeline, the event's appearance (color) remains the same.

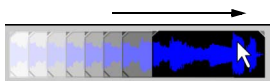

However, you may move the event to a different track. When you do, the event appears as a simple outline and you will see its original track and position on the timeline. Once you release the mouse, the event assumes the new timeline position and track color.

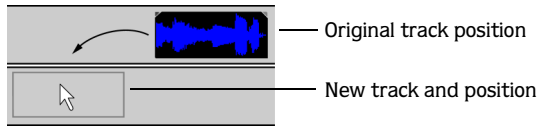

2. Release the mouse to place the event.

Moving multiple events

You can move multiple events along the timeline within a track or move them to a different track. Selected events do not need to be within the same track. Use the **Ctrl** key, the **Shift** key, or the Selection Edit Tool () to select multiple events and drag them. To select all events on the track after a given event, right-click the event and choose **Select Events to End**. For more information, see [Selecting multiple events](#) on page 60.

Moving events by small increments

To move an event more precisely, click the event and press 4 or 6 on the numeric keypad to nudge it by small increments. The amount of movement caused by each nudge is determined by how far the timeline is zoomed in or out. You can also click the event and press 1 or 3 on the numeric keypad to nudge the event by frames.

Moving grouped events

Groups allow you to move multiple events within their tracks as a single unit. While you can create your own groups as needed, groups are automatically created for you when video files with associated audio (e.g., AVI) are added to a project. When you add these video files, the audio portion of the video file is inserted into the timeline as a separate audio event. The video and audio events are grouped and can be moved as a single unit within their respective tracks.

To move grouped events, drag any event in the group to a new position. For more information, see [Grouping events](#) on page 141.

Working with tracks





A project consists of multiple audio and video tracks. The **track view** is the timeline in which all events appear. The **track list** provides information about the track and contains controls that affect all events in the track.

Using the track view

Numerous options are provided for viewing and navigating in track view.

Scrolling and zooming





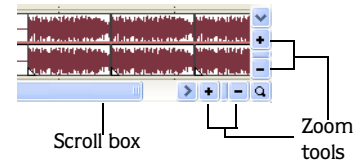

There are several ways to scroll and zoom in the track view.

- Click the scroll bar arrows or drag the scroll bars to move up and down the tracks or to move forward and back along the timeline.
- Click the Zoom buttons () to reveal more or less of the timeline.
- Drag the edge of the scroll box, found on the scroll bar, to zoom.
- Press  and  to zoom in and out along the timeline.
- Click the Zoom Edit Tool () button or, from the **Edit** menu, choose **Editing Tool** and then choose **Zoom**. In this mode, drag on the timeline to draw a rectangle that defines the zoom region.



Tip: You can also access the Zoom Edit Tool from the lower-right corner of the track view ().

Mouse wheel control is also supported. The default behavior of the wheel is to zoom horizontally.

- +wheel scrolls horizontally (through time).
- +wheel scrolls vertically.
- ++wheel moves the cursor in small increments.
- +++wheel moves the cursor in one-frame increments.
- Clicking the mouse wheel turns auto-panning on and off.

Zooming directly controls the accuracy of your editing. Each video event has thumbnail representations of the frames within the event. Depending on how far you have zoomed in on a video event, a thumbnail can represent the entire event or a single frame in the event.

Tip: You can choose to display frame numbers, time, or timecode on video event thumbnails. For more information, see [Displaying frame numbers](#) on page 287.

Changing track height

You can change the height of individual tracks by dragging their borders in the track list. In the example below, the main video track is fairly large to show the details of the scene while the two tracks above it, which are overlays, have been resized to a shorter height. For more information, see [Changing track height](#) on page 108.

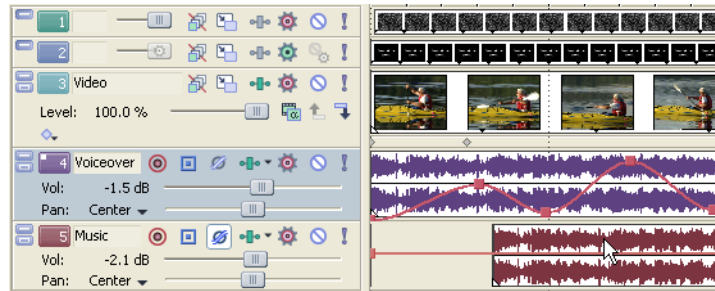

Using the track list

This section describes the different controls in the track header of each track. Some controls are specific to either video or audio tracks.









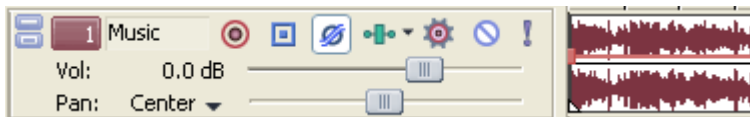



Video track header



Button or Control	Name	Description
	Make compositing child	Creates a parent/child compositing relationship with the track above. Used when creating masks. For more information, see Understanding the parent/child track relationship on page 212.
	Track number and color	Track numbers and colors help organize a multitrack project. For more information, see Managing tracks on page 105.
	Minimize track height	Minimizes track height. For more information, see Changing track height on page 108.
	Maximize track height	Maximizes track height. For more information, see Changing track height on page 108.
	Expand track keyframes	Displays track keyframes on the timeline. For more information, see Working with keyframes in track view on page 240.
	Bypass motion blur	Bypasses motion blur envelope for a track. For more information, see Using video bus tracks on page 115.
	Track motion	Track motion is used to move a video track across a background. Picture-in-picture effects and scrolling title sequences are two simple cases where this tool is important. For more information, see Adding track motion on page 245.
	Track FX	Adds track effects plug-ins. For more information, see Using video effects on page 205.
	Mute	Temporarily suspends playback of the track so that you can focus on other tracks. For more information, see Muting a track on page 113.
	Solo	Isolates a track for playback by muting the other tracks. For more information, see Soloing a track on page 114.
	Track name (scribble strip)	Allows you name a track. To name a track, double-click the scribble strip and type the track's name. For more information, see Naming or renaming a track on page 106.
	Composite level slider	Determines the opacity/transparency of the video track. Drag the slider to control the transparency or blending of the track. Left is 100% transparent and right is 100% opaque. You can also double-click the label to enter a specific numeric percentage.
	Compositing mode	Determines how the transparency in a video track is generated. For more information, see Selecting compositing modes on page 213.

Audio track header

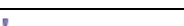

Button or Control	Name	Description
	Track number and color	Track numbers and colors help organize a multitrack project. For more information, see Managing tracks on page 105.
	Minimize track height	Minimizes track height. For more information, see Changing track height on page 108.
	Maximize track height	Maximizes track height. For more information, see Changing track height on page 108.
	Track name (scribble strip)	Allows you name a track. To name a track, double-click the scribble strip and type the track's name. For more information, see Naming or renaming a track on page 106.
	Arm for record	Prepares a track for recording. You may record directly into audio tracks. A track is ready when you see the recording meter appear on it. For more information, see Arming the track for recording on page 165.
	Bus assignment	Assigns an audio track to a specific output bus. This option is available for projects being mixed for multiple stereo busses. For more information, see Assigning audio tracks to busses on page 149.
	Invert Track Phase	Inverts the audio track at its baseline, in effect reversing its polarity. For more information, see Phase inverting a track (audio only) on page 113.
	Track FX	Adds track effects plug-ins. For more information, see Using audio effects on page 153.
	Mute	Temporarily mutes playback of the track so that you can focus on other tracks. For more information, see Muting a track on page 113.
	Solo	Isolates a track for playback by muting the other tracks. For more information, see Soloing a track on page 114.
	Volume fader	Controls the audio track volume relative to the other tracks. Drag the fader left or right to adjust the volume. For more information, see Using the volume fader (audio only) on page 109.
	Multipurpose slider	Controls several features, including track panning, bus send levels, and assignable effects send levels. Select what the slider controls by clicking the label. Each item's slider position is independent from the others. For more information, see Using the multipurpose slider (audio only) on page 110.

Playing back and previewing

You can play back your project in two ways: directly from the timeline from within the software or by mixing the entire project to a preview file.

Playing your project

The transport bar allows you to play back your entire project or portions of your project based on a time selection or the current cursor position.



If your project includes video, make sure the Video Preview window is displayed for playback: from the **View** menu, choose **Video Preview** or press **Alt + G**.

Playing an entire project

1. Click the Play From Start button (▶) to begin playback at the beginning of the project.
2. Click the Stop button (■) to stop playback.

Most of the time, you will only want to preview a small portion of the project to perfect a section. You can do this by creating a time selection.

Playing a time selection

1. Place the mouse pointer above the ruler on the marker bar. The mouse pointer changes to include a left/right arrow cursor (↔).
2. Drag to select the time region. To increase or decrease the time selection, drag its start and end points. The time selection is highlighted and the loop bar appears above the ruler on the timeline.
3. Click the Play button (▶) to begin playback. Only the non-muted tracks and events within the time selection play back.
4. Click the Loop Playback button (🔄) to continually play back the events within the time selection. Click the button again to toggle this feature off.
5. Click the Stop button (■) to stop playback.

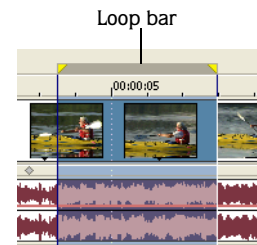









By looping the playback, you can repeatedly watch the same section of the project over and over as you make changes to filters and effects in real time. You can define selection areas automatically, depending on what you would like to preview. For more information, see [Selecting a time range on page 61](#) and [Time selection commands on page 28](#).

Playback reference

The following table describes all the transport bar buttons and their keyboard equivalents. You may use these playback functions at any time while working in your project.

Note: *The use of many multimedia keyboards is also supported for controlling playback.*

Button	Keyboard	Function
	Ctrl + R	Begin recording into record-enabled tracks
	Q	Turn on/off loop playback during time selection playback
	Shift + Space	Begin playback from the start of the project
	Space	Begin playback from cursor position
	Enter	Pause playback, cursor stops and holds at pause position
	Space or Esc	Stop playback, cursor stops and returns to prior cursor position
	Ctrl + Home	Place cursor at the beginning of project
	Ctrl + End	Place cursor at the end of the project

Tip: *You can use the spacebar to stop or pause playback, depending on your preference. From the **Options** menu, choose **Preferences**, and on the **General** tab, select **Make spacebar and F12 Play/Pause** instead of **Play/Stop** to change the setting.*

Scrubbing

Scrubbing is a type of timeline playback that gives you precise control over the speed and direction of playback. Both linear and logarithmic scale scrubbing are allowed. For more information, see [General tab](#) on page 294.

The use of multimedia controllers is supported for scrubbing. For more information on using the software with multimedia controllers, please see the online help. To access help, choose **Contents and Index** from the **Help** menu.

Tip: *Choose a setting from the JKL / shuttle speed drop-down list on the **Editing** tab of the **Preferences** dialog to control the scrub speed and range when using the keyboard or multimedia controllers.*

Three methods of scrubbing are provided.

Scrubbing with the scrub control slider

The scrub control slider can be dragged back and forth. The farther from the center that the slider is dragged, the faster the playback, both forward and in reverse. Below the slider is a small yellow marker that can be used to set the normal rate playback speed. This is the speed at which the project plays when you click the Play button on the transport bar.



Scrub control slider

Scrubbing on the timeline

The second way that a project can be scrubbed is by positioning the mouse pointer over the timeline cursor at a location that is not over any events and pressing **[Ctrl]**. The cursor changes to a speaker icon. Now, when you left-click, the cursor icon changes again to a pan/scrub icon. Drag the mouse left or right to scrub the timeline.

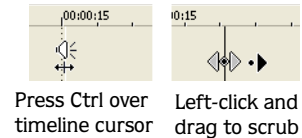

Tip: You can also choose to enable timeline scrubbing when the mouse is positioned over events. From the **Options** menu, choose **Preferences**, and select **Allow Ctrl+drag cursor style scrub over events** on the **General** tab.

Scrubbing with the keyboard

Three letters (JKL) are used as a keyboard scrub control.

Note: Choose a setting from the **JKL / shuttle speed** drop-down list on the **Editing** tab of the **Preferences** dialog to control the scrub speed and range.

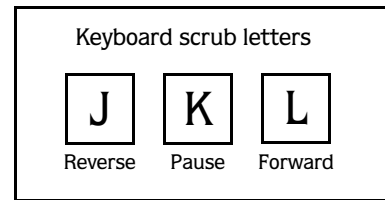

Press **[J]** for reverse and **[L]** for forward playback. Press **[K]** to pause playback.

There are several ways to adjust playback speed:

- Adjust the **JKL / shuttle speed** selection on the **Editing** tab of the **Preferences** dialog.
- Hold **[K]** while pressing **[J]** or **[L]** to emulate a shuttle knob mode. Press **[K] + [J]** to turn the knob to the left or **[K] + [L]** to turn the knob to the right. Press **[K]** again or **[Space]** to return to normal mode.

Previewing to media player

A project can be previewed in a media player by mixing and rendering the project according to the project's properties and playing back using the media player associated with the file type you select.

1. From the **Tools** menu, choose **Preview in Player**. The **Preview** dialog appears.
2. Select the file type from the drop-down list.
3. Click **OK** to begin the mixing and rendering process. A progress dialog appears indicating the percent complete of the new file.

Note: You may cancel the preview by clicking the **Cancel** button on the status bar.

When mixing is completed, the associated media player opens and begins playback.

Prerendering video previews

Playing a project using the transport controls can instantly show how a project is progressing, but it does not actually render your project in its final form. The preview you see in the **Video Preview** window may be different from your final project in a number of ways: frame size, frame rate, and quality. In most cases, the **Video Preview** is all you need for checking the timing of events in your project. Eventually, however, you may need to output a full-quality preview of a section of your project. To do this, from the **Tools** menu, choose **Selectively Prerender Video**. For more information, see [Prerendering video](#) on page 255.

Rendering a project

Rendering refers to the process of creating a new media file from a Vegas project. The project file is not affected (overwritten, deleted, or altered) during the rendering process. You may return to the original project to make edits or adjustments and render it again. The following table describes the formats available for rendering your project:

Format Name	Extension	Definition
Audio Interchange File Format	.aif	The standard audio file format developed by Apple® and used on Macintosh® computers.
MPEG-1 and MPEG-2	.mpg	MPEG-1 and MPEG-2 file creation are supported through the use of MainConcept® MPEG technology.
MPEG Layer 3	.mp3	Compressed audio format. You may render up to 20 .mp3 files without registering the optional plug-in.
OggVorbis	.ogg	A patent-free audio encoding and streaming technology.
QuickTime	.mov	Apple QuickTime multimedia format.
RealMedia®	.rm	The RealNetworks® standard for streaming media via the Web. This option renders both audio and video into one file.
Scott Studios Wave	.wav	Standard audio format used with Scott Studios systems.
AC-3	.ac3	Encoded Dolby Digital surround sound format. This option creates six mono files (WAV or AIFF) that your authoring application can use to create DVD-Video or 5.1-channel music projects.
Perfect Clarity Audio	.pca	A proprietary format from Sony Pictures Digital that is compressed and completely lossless.
Wave64	.w64	A Sony Pictures Digital proprietary format that allows wave files that are (practically) unrestricted by file size.
Video for Windows	.avi	The standard video file format used on Microsoft® Windows®-based computers. This option renders both audio and video into one file.
Wave (Microsoft)	.wav	The standard audio file format used on Microsoft Windows-based computers.
Windows Media Audio	.wma	The Microsoft audio-only format used to create files for streaming or downloading via the Web.
Windows Media Format	.wmv	The Microsoft standard used for streaming audio and video media via the Web.

More detailed instructions for rendering to a specific format appear later in this manual. *For more information, see [Saving, Rendering, and Printing Projects](#) on page 269.*

Creating a movie

To create a movie, you render the project into an appropriate media file output. The final output format depends on the destination of the new media file. Some examples are AVI, MOV, and WMV.

1. From the **File** menu, choose **Render As**.
2. In the Render As dialog box, choose the appropriate option from the Save as type drop-down list.
3. Click Custom to select custom compression settings. The default compression options are set automatically according to your project's properties. *For more information, see [Customizing the rendering process](#) on page 275.*
4. Enter a name and browse for a destination for your file.
5. Click OK.



Basic Editing Techniques

Vegas® projects are multitrack compilations of events that occur over time. The events in your project are references (pointers) to source media files. Vegas software is a nondestructive editor, so editing events in your project does not alter the source media files in any way.

Getting around

When editing and playing back the project, the cursor identifies where you are along the project's timeline.

Moving the cursor

Use the following keyboard commands to move the cursor in the timeline.

Description	Keys	Description	Keys
Go to beginning of project	Ctrl+Home or W	Move left/right to marker(s)	Ctrl+Left/Right Arrow
Go to end of project	Ctrl+End or E	Move to marker #	0-9 keys (not numeric keypad)
Go to beginning of selection or view (if no selection)	Home	Move left/right to event edit points including fade edges (see figure below)	Ctrl+Alt+Left/Right Arrow
Go to end of selection or view (if no selection)	End	Nudge cursor on timeline	Left or Right Arrow
Move right by grid marks	Page Down	Move left/right one frame	Alt+Left/Right Arrow
Move left by grid marks	Page Up	Move left/right one frame	Ctrl+Alt+Shift+Mouse wheel
Go to	Ctrl+G	Center in view	\



Event edit point cursor jumps

Changing focus

Focus is used to describe which objects have the attention of a program. For example, when you click a file in the Media Pool, the Media Pool window has focus. To instantly switch the program's focus to the track view (timeline), press **Alt** + **0** or, from the **View** menu, choose **Focus to Track View**.

In Vegas software, it matters which track has focus when you perform a task. For example, when you double-click a media file in the Explorer, it is inserted into the track that has focus. You can click a track on its track number to make it the focus track. A blinking white line under the track number and shading in the track list indicates a track has focus.

Making selections

You have the flexibility to select one or more events, a time range, or events *and* a time range. All selection options can apply to a single track or to multiple tracks.

To select an event, click it.

Selecting multiple events

You can select multiple events in your project using several methods.

Tip: Once you have selected multiple events, you can group them together. For more information, see [Grouping events](#) on page 141.

Note: You can select multiple video events, multiple audio events, or a combination of both video and audio events. However, you can only use commands and operations that apply to both types of events for selections composed of both audio and video events.

Selecting nonadjacent events

1. Hold the **[Ctrl]** key.
2. Select the events by clicking them.

To deselect an event, simply click it again to toggle the event selection on or off.

Selecting a range of events

1. Hold the **[Shift]** key.
2. Click the first event that you want to select.
3. Click the last event that you want to select.

All events between the first and last selected events are highlighted and selected.

Selecting a block of events

1. Click the Selection Edit Tool button (.
2. Position the cursor in a corner of the area that you want to select.
3. Click and hold the left mouse button.

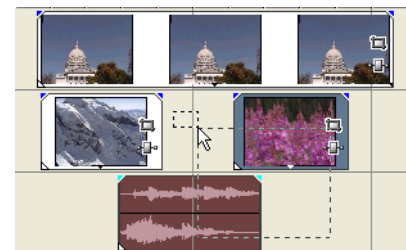
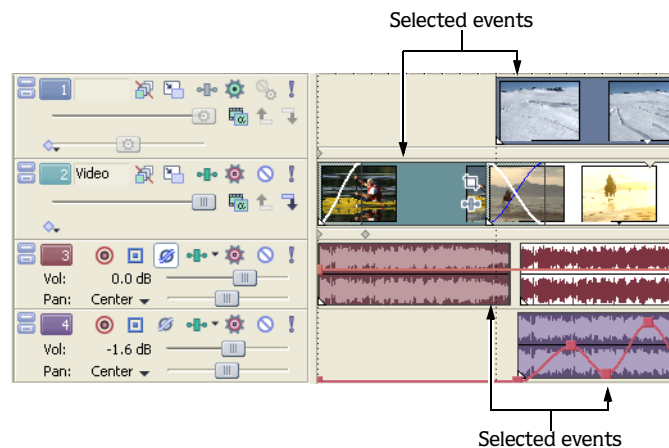

4. Drag the cursor to the opposite corner of the area you want to select. A rectangle is drawn on the workspace. All events within this rectangle are selected.

Hold the left mouse button and right-click to toggle through the three types of selection boxes: free, vertical, or horizontal.

Tip: You may include or exclude events from a selection area by pressing **Ctrl** and clicking an event. To deselect all events, click anywhere in the workspace outside of the selected events.

Selecting all events to the end of the track

1. Right-click an event. A shortcut menu appears.
2. From the shortcut menu, choose **Select Events to End**. All events on the track after the selected event are selected.

Tip: To move large blocks of events, you can use **Select Events to End** with events selected on different tracks. Press **Ctrl** and click to select events on different tracks, and then right-click to access the shortcut menu.

Selecting all events that refer to a specific media file

Right-click a file in the Media Pool and choose **Select Timeline Events** from the shortcut menu. All events that use the selected media file in the active take are selected.

Hold **Ctrl** or **Shift** while choosing **Select Timeline Events** from the shortcut menu to add the events to the current selection.

Selecting a time range

Time selections are indicated by a shaded box and a bar that appears on the top of the timeline. You can use the time selection bar for playing back a smaller portion of your project or to apply cross-track edits.

Note: Unless an event is locked, a selected time range affects all events, or portions of events, that occur within the range.

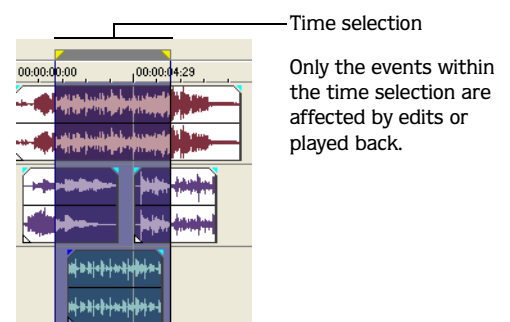

Dragging to select a time range

1. Position the mouse pointer above the ruler (on the marker bar). The mouse pointer changes to a left/right arrow cursor (↔).
2. Drag to select a region. All events, or portions of events within the region are highlighted.
3. Drag the yellow handles on either end of the time selection to increase or decrease your time range selection.

Tip: You can move the entire selection range by dragging the time selection bar.

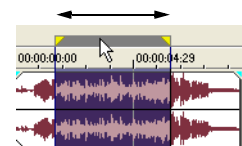

Selecting a time range during playback

1. Click the Play (▶) or the Play From Start (▶) button to begin playback.
2. Press [I] where you want the time selection to begin.
3. Press [O] where you want the time selection to end.
4. Click the Stop button (■) to stop playback.

Using shortcuts for time selections

These shortcuts can speed up the process of making precise time selections.

Description	Shortcut
Set time selection duration equal to an event's duration	Double-click the event
Extend selection to the end of the currently selected event edge	Ctrl+Shift+Alt+Right Arrow
Extend selection to the beginning of the currently selected event edge	Ctrl+Shift+Alt+Left Arrow
Drag a time selection on an event without selecting/deselecting the event	Ctrl+Shift+drag on the event

Tip: Press [Backspace] to recall the last five time selection areas.

Looping playback

If you want to play back the time range, click Play (▶) to play only the events within the time range. Click the Loop Playback button (🔄) or press [Q] to toggle loop playback on and off. Vegas software continually plays back the portion of the timeline within the time selection when loop playback is toggled on.

Selecting events and a time range

Selecting a time range does not automatically select events. Excluding locked events, all items within the time range play back and are affected by **Edit** menu commands. However, you may select specific events to edit, and then select a time range.

1. Select the events you wish to edit. For more information, see [Selecting multiple events](#) on page 60.
2. Place the mouse pointer above the ruler (on the marker bar). The mouse pointer changes to a left/right arrow cursor (↔).
3. Drag to select the region. Notice that events that were not initially selected in step 1 remain unselected (not highlighted).

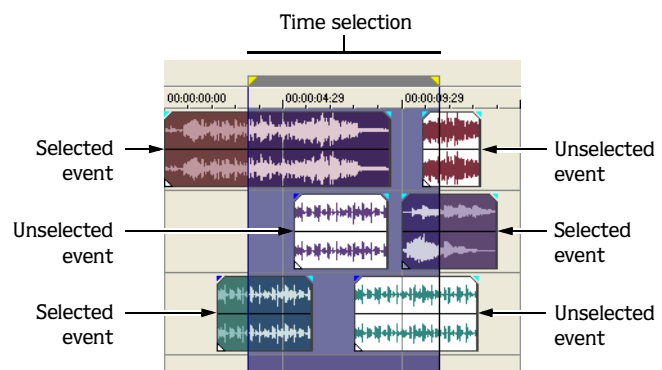

Selecting tracks

Click a track header to select it. Hold [Ctrl] or [Shift] to select multiple tracks.

Selecting groups of composited tracks

Click the vertical bar below a parent track to select a group of composited tracks. For example, clicking the area marked A in the following track list to select tracks 2 through 6. Clicking the area marked B selects tracks 5 and 6.

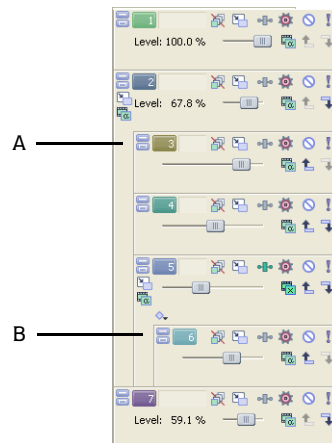

Editing events

Copying events

You can copy events, or portions of events, to the clipboard and paste them into your project. You may copy a single event or multiple events. Copying preserves the original event information, edits, and other modifications.

1. Select the events to be copied. *For more information, see [Selecting multiple events](#) on page 60.*
2. Select a time range, if applicable.
3. Click the Copy button ().

Copying selected events

When copied, selected events are reproduced and placed on the clipboard. Time information is also placed on the clipboard.



Copying a time selection

Events within the time selection and across all tracks are reproduced and placed on the clipboard. Time information is also placed on the clipboard.

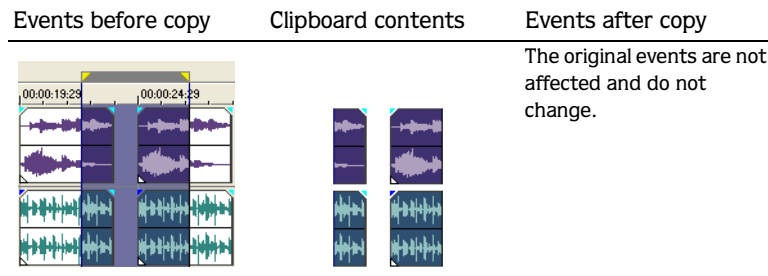

Copying a time selection and events

Events and portions of selected events within the time selection are reproduced and placed on the clipboard. Time information is also placed on the clipboard.

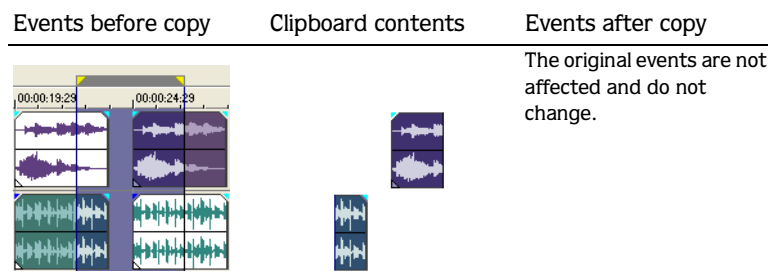

Cutting events

Cutting events removes them from their respective tracks, but places the cut information (events and time) on the clipboard. Once on the clipboard, you may paste the information into your project.

Tip: You can apply a ripple edit after cutting. For more information, see [Applying post-edit ripples](#) on page 73.

1. Select events or a time range. For more information, see [Making selections](#) on page 60.
2. Click the Cut button (✂).

Cutting selected events

When cut, selected events are removed from the timeline and placed on the clipboard. Time information is also placed on the clipboard.

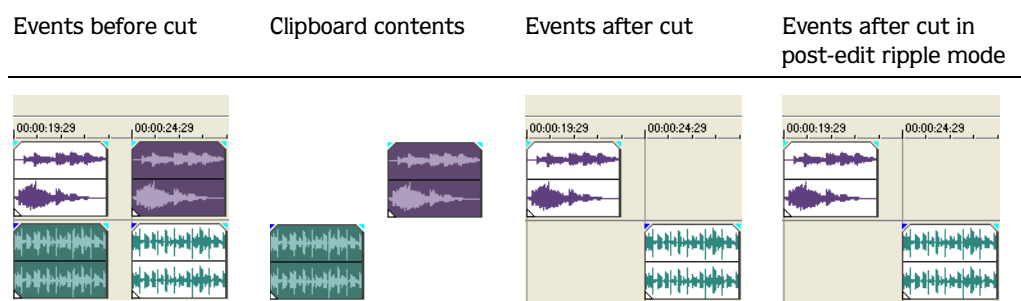

Cutting a time selection

Events within the time selection are reproduced and placed on the clipboard. Time information is also placed on the clipboard. When cutting a time selection, ripple edit mode affects the position of material on all tracks or affected tracks after the cut.

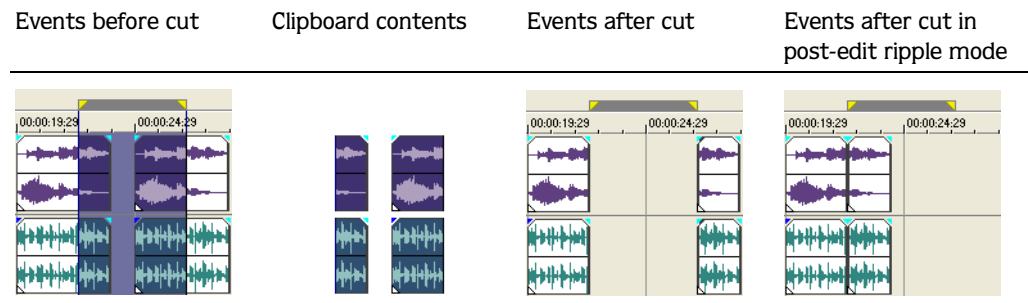

Cutting a time selection and events

Events and portions of selected events within the time selection are reproduced and placed on the clipboard. Time information is also placed on the clipboard. When cutting a combination of time selection and event selection, post-edit ripple mode affects the position of material on all tracks or the tracks of selected events after the cut.

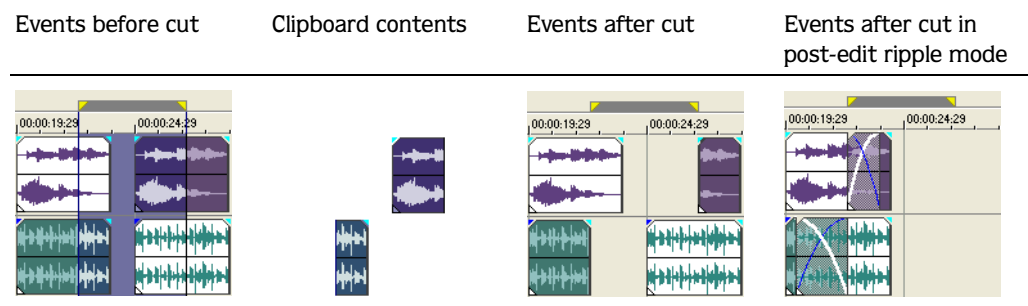

Pasting events

Once information is copied to the clipboard, you may choose a variety of ways to paste the clipboard items. Items are always pasted from the cursor's position along the timeline.

When post-edit ripple mode is enabled, material is pushed down the track to make room for pasted material. The exact behavior of the ripple depends on what is being pasted, and the type of ripple edit you chose to perform. If one or more events are pasted, only those tracks where pasted material appears are ripple edited.

Tip: You can apply a ripple edit after pasting. For more information, see [Applying post-edit ripples](#) on page 73.

1. Move the cursor to the desired location on the timeline.
2. Click either the track number or within the track where you want to paste the event. This track is the focus track; there can be only one focus track at a time.

Note: If you are pasting multiple events from different tracks, new tracks are automatically created as needed.

3. Click the Paste button ().

Clipboard events are pasted at the cursor position on the track. Existing track events can be overlapped with newly pasted information.

Using paste repeat

Use paste repeat to specify how many times clipboard events are pasted at the cursor position on the selected track and to specify the space between pasted events.

1. Copy a selection to the clipboard.
2. From the **Edit** menu, choose **Paste Repeat**. The Paste Repeat dialog appears.
3. Specify the number of times to paste the clipboard contents and the space between successive copies.
4. Click OK.

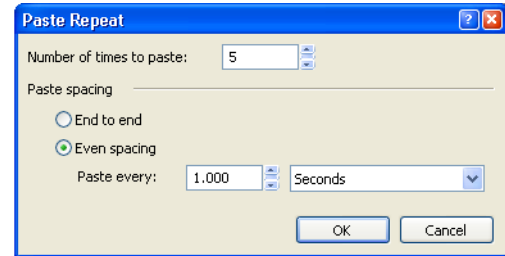

Using paste insert

When using paste insert, clipboard events are placed at the cursor position on the selected track and existing events on all tracks are moved further down the timeline by the total length of pasted information. This action differs from post-edit ripple mode because pasting in post-edit ripple mode affects only the tracks in which material is pasted, while paste insert affects all tracks in the project.

1. Copy a selection to the clipboard.
2. From the **Edit** menu, choose **Paste Insert**

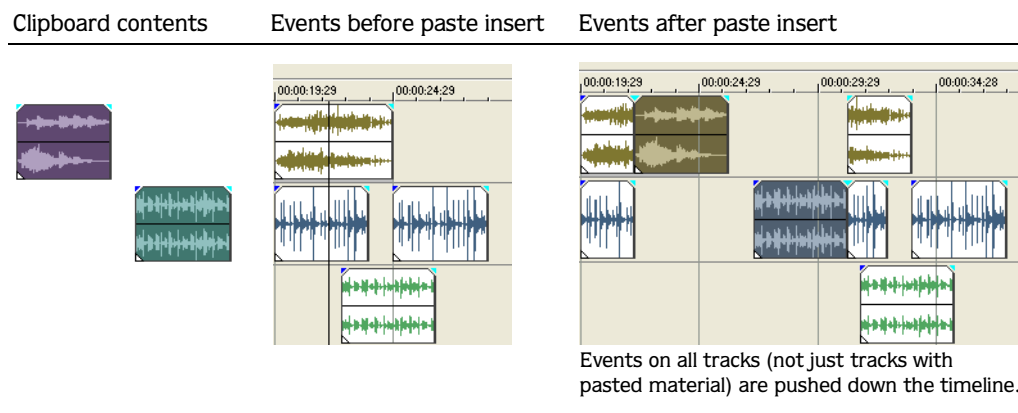

Punching-in and crossfading events

You can insert events into the middle of (on top of) existing events without altering the timing of the project. When the inserted event ends, the original event continues playing as if it had never stopped.

You can choose the duration of crossfades for punched-in audio events.

1. From the **Options** menu, choose **Preferences**. The Preferences dialog appears.
2. Click the Editing tab.
3. Select Quick fade length of audio events. Specify a duration for each transition.

Events that have previously been inserted or punched-in are not affected by this change. The concept of punching in and out only applies when you are inserting an event that is shorter than the event that it is being inserted into. In the following illustration, every frame is numbered so that you can see how the original event continues after the inserted event ends, as if it continued to play underneath the original.

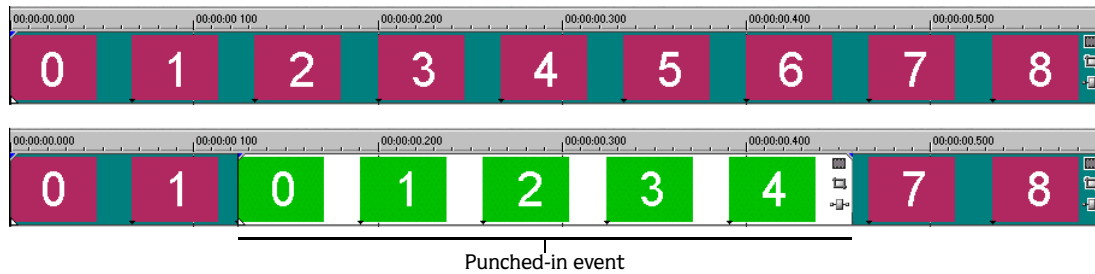

Duplicating events

Duplicating is a combination of copying and pasting in one action. The process is like moving the event to a new position while leaving a copy behind.

1. Press **Ctrl**.
2. Drag the event you want to duplicate to the place where you want the new event to be positioned.

Inserting empty events and time

You can insert events into the timeline that do not have any contents and are not references to any media files. Empty events are useful as placeholders in the timeline that can be filled with media or recorded into at a later time. In either case, the new media is added to the empty event as a take. *For more information, see [Working with takes](#) on page 94.* To add an empty event to a track, from the **Insert** menu, choose **Empty Event**.

You can also make space in a project by inserting a length of time across all tracks. To insert a period of time into the timeline, from the **Insert** menu, choose **Time**.

Trimming events

This section describes simple ways to trim events. *For more information, see [Using the Trimmer window](#) on page 96.*

Tip: You can apply a ripple edit after trimming an event. *For more information, see [Applying post-edit ripples](#) on page 73.*

Trimming an event

During the trimming process for a video event, both the last thumbnail image on the event and the Video Preview window show the last frame in the event, allowing you to edit events very accurately.

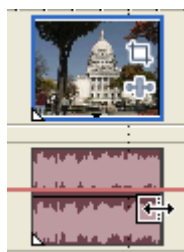

Trimming grouped events at the same time

1. Move the cursor over the edge of the event. The cursor changes when properly positioned (\leftrightarrow).
2. Drag the edge of the event to trim it.

Since a multimedia file often has both a video and an audio component, both events are trimmed (or extended) as a group unless you ungroup them or temporarily suspend grouping by clicking the Ignore Event Grouping button (). *For more information, see [Grouping events](#) on page 141.*

Trimming an event beyond its end

You can trim an event beyond its end, extending it as a result. Once extended, the event loops as a default. A notch indicates where the looped event repeats.

Alternately, you can turn looping off and make the last frame of an event's media repeat for the duration of the event (a freeze frame). A notch appears at the point in the event where the video ends and the freeze frame begins. *For more information, see [Loop](#) on page 133.*

Trimming adjacent events

You can trim adjacent events simultaneously. Press **Ctrl** + **Alt** while dragging the common edge between two adjacent events. The trim adjacent cursor appears ()

Press **Ctrl**+**Alt** over the boundary between two events...

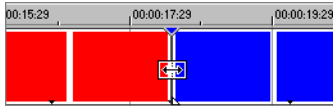

...and drag left...

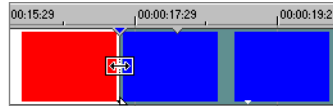

...or right to trim both events at once.

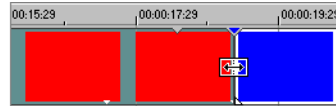

Trimming a time selection

Trimming events removes all media *outside* the time selection. The removed information is not placed on the clipboard. Trimming is different from cutting in that the events *within* the time selection are preserved.

1. Select a time range. *For more information, see [Selecting a time range](#) on page 61.*
2. Press **Ctrl** + **T** or, from the **Edit** menu, choose Trim.

The material *outside* the time selection (across all tracks) is removed from the project. However, the time information (space) between events is not removed.

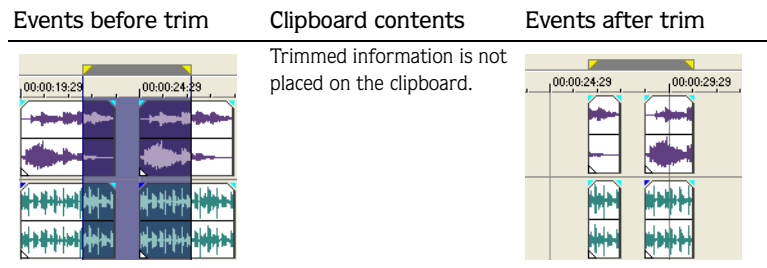

Trimming a time and event selection

1. Select the events to be trimmed.
2. Select a time range. *For more information, see [Selecting events and a time range](#) on page 62.*
3. Press **Ctrl** + **T** or, from the **Edit** menu, choose Trim.

Only the portion of selected events *outside* the time selection is trimmed. Unselected events remain. The time information (space) between events is not removed.

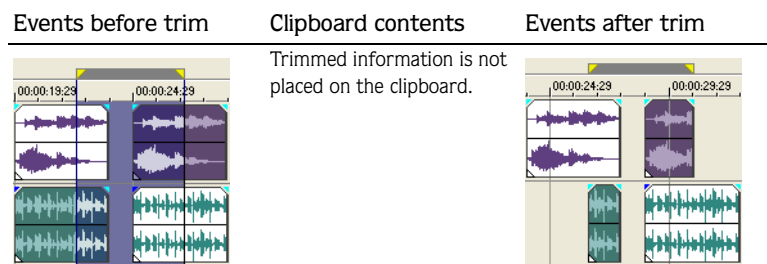

Edge trimming events using the keyboard

With this method, you can quickly jump through your project and adjust cuts until they're perfectly synchronized. If you have an external multimedia controller, it's even easier.

1. If you want downstream events to ripple as you trim, click the Auto Ripple button () to turn on Auto Ripple mode.
2. Select the event you want to trim.
3. Press 7 or 9 on the numeric keypad to move the cursor to the event edge you want to trim. 7 selects the beginning of an event or moves to the previous event edge. 9 selects the end of the event or moves to the next event edge. A red bracket is displayed to indicate which event edge will be trimmed.

Note: You can also perform this step using the [or] keys.

4. Use the 1, 3 and 4, 6 keys on the numeric keypad to trim the current event edge:
 - Press 1 to trim one video frame left, or press 3 to trim one video frame right (or hold **Ctrl** + **Shift** + **Alt** while rolling the mouse wheel).
 - Press 4 to trim one pixel left, or press 6 to trim one pixel right (or hold **Ctrl** + **Shift** while rolling the mouse wheel). Depending on the current zoom level, the trim duration will vary.

Note: Pressing 5 on the numeric keypad exits edge-trimming mode. If you are not in edge-trimming mode, 1, 3, 4, and 6 on the numeric keypad to nudge events on the timeline by frame (1 and 3) or by pixel (4 and 6).

5. Repeat steps 3 and 4 as necessary.

Splitting events

You are allowed to create multiple, independently functioning events from a single event by splitting it. Splitting creates a new ending point for the original event and creates a starting point for the newly created event.

Splitting an event does not alter the original media. The original media file's information is there, but is omitted for playback based on where the event's starting or ending point occurs on the timeline.

When split, the two new events are flush against one another. The two events can be moved independently.

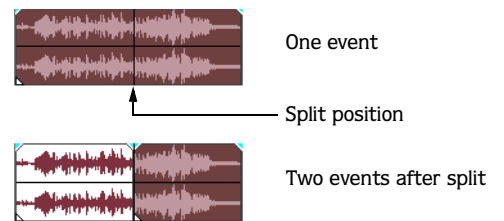

Splitting an event

1. Select the event(s) to be split. For more information, see [Making selections on page 60](#).
2. Place the cursor at the timeline position where the split will occur.
3. From the **Edit** menu, choose **Split**, or press **S**.



Splitting all events at the cursor

All events are split at the cursor's position (unless an event is locked). The split occurs across all tracks (if no events are selected).

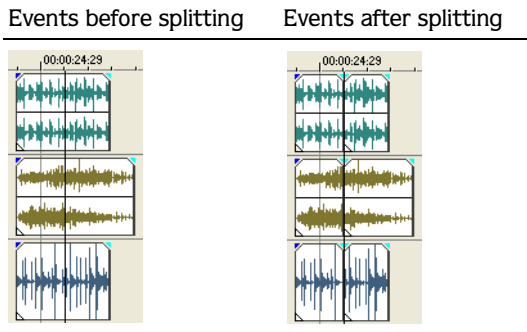

Splitting selected events

Only the selected events are split at the cursor's position.

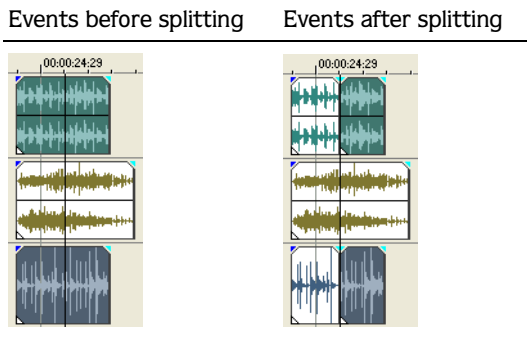

Splitting a time selection

Unless locked, all events within the time selection are split at the starting and ending points of the time range, meaning that two splits are made. The split occurs across all tracks.

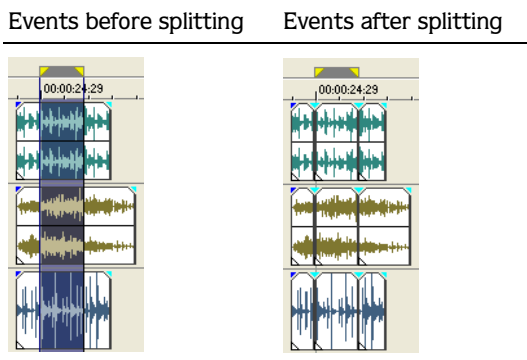

Splitting a time selection across selected events

Only selected events within the time selection are split at the starting and ending points of the time range.

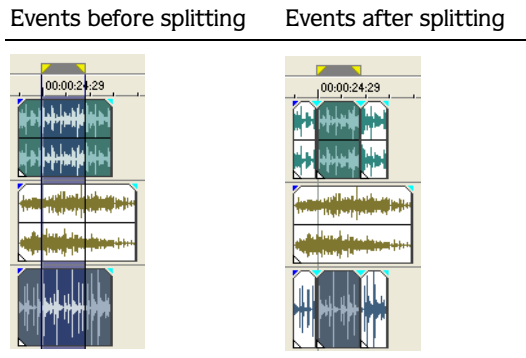

Slipping and sliding events

To help you picture what happens when you slip and slide events, think of an event as a window to a media file. The window can display the entire media file or a small section. When the window displays only a portion of the media file, you can move either the window or the underlying media to adjust the media that is played by an event:

- When you **slip** an event, your event maintains its place on the timeline, but the media file moves in the direction you drag.
- When you **slide** an event, the media file maintains its place on the timeline, but the event moves in the direction you drag.

Tip: You can also slip or slide grouped events (at the same time) or slide a crossfade between two events. For more information, see [Grouping events on page 141](#) or [Sliding a crossfade on page 76](#).

Shifting the contents of (slipping) an event

Press **Alt** while dragging an event. The slip cursor appears (⇄).

As you drag the event, the contents of the event shift, but the event does not move. You can use this technique when you want to maintain an event's length and position, but have the event play a different section of the source media file.

Slip-trimming an event

Press **Alt** while dragging the right or left edge of an event. The slip-trim cursor appears (⇄|).

As you drag the event edge, the media moves with the event edge.

Sliding an event

Press **Ctrl** + **Alt** while dragging an event. The slide cursor appears (↔).

As you drag, the relative position of the media remains fixed on the track, and the event position changes. You can use this technique when you want to maintain an event's length, but have the event play a different section of the source media file at a different point in your project.

Tip: You can apply a ripple edit after slip-trimming or sliding an event. For more information, see [Applying post-edit ripples](#) on page 73.

The original media file.



The event on the timeline with original frames.

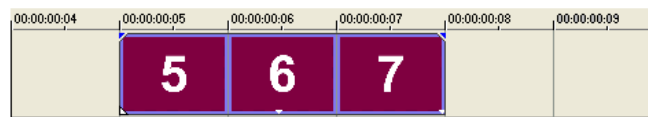

Slipping the event two frames to the right.

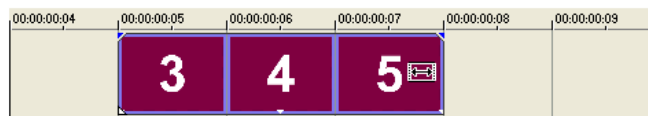

Slip-trimming the event two frames to the right.



Sliding the event two frames to the right.

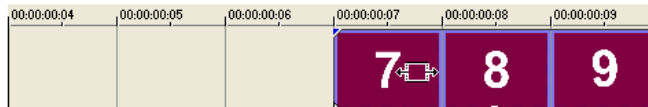

Deleting events

Deleting an event removes it from its track. Multiple events can be deleted and time selections can be used to modify the process. Ripple editing also applies to delete actions. Deleting operates exactly like a cutting operation, but the removed information is *not* placed on the clipboard. For more information, see [Cutting events](#) on page 64.

1. Select the events to be deleted.
2. Press **Delete**.

Applying post-edit ripples

You can apply a post-edit ripple that affects either the edited track(s), the track(s) and certain project elements, or everything in the timeline. The power lies in the fact that you can apply this post-edit ripple to a wide variety of editing tasks, such as trimming, crossfading, cutting, pasting, and deleting events. You can also choose to apply your ripple edits manually or automatically.

You can ripple the contents of the timeline following an edit after performing these tasks:

- trimming (pg. 67), slip-trimming (pg. 71), and sliding (pg. 72) events
- time compressing/stretching events (pg. 93)
- cutting events (pg. 64)
- pasting events (pg. 65)
- deleting events (pg. 72)

Ripple editing also affects how material is added from the Trimmer window. *For more information, see [Using the Trimmer window](#) on page 96.*

The original four events

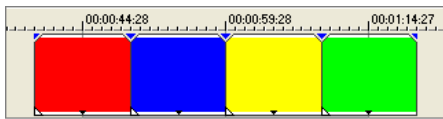

Trimming the second event

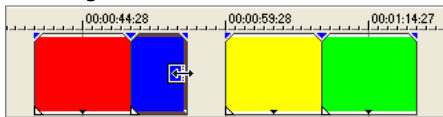

After applying a post-edit ripple, the third and fourth events close the gap

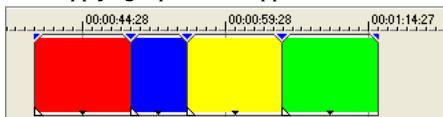

A quick and easy method is also provided for shuffling a sequence of events on a track. Decide that the third event in a series should really be the second instead? You can drag the event to a new position and instruct the software to shuffle the events into their new order.

Applying a post-edit ripple manually

1. Perform one of edits discussed above. Above the timeline, an arrow indicates where the post-edit ripple will occur and the direction the affected events will move.

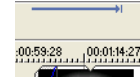

2. From the **Edit** menu, choose **Post-Edit Ripple**, and choose a command from the submenu:
 - **Affected Tracks** ripples only the track(s) where you performed the edit.
 - **Affected Tracks, Bus Tracks, Markers, and Regions** ripples the track(s) where you performed the edit and ripples any keyframes or envelopes on those tracks. This command also ripples any markers, regions, CD layout markers, and command markers in the project.
 - **All Tracks, Markers, and Regions** ripples all tracks and all keyframes and envelopes on those tracks. This command also ripples any markers, regions, CD layout markers, and command markers in the project.

The timeline is rippled after the edit according to the option you choose.

Tip: You can press **[F]** after an edit to ripple the affected tracks, or you can press **[Ctrl]+[F]** to ripple markers, keyframes, and envelopes too. To ripple everything after an edit, press **[Ctrl]+[Shift]+[F]**.

Applying a post-edit ripple automatically

1. Click the arrow button next to the Auto Ripple button () and choose a ripple type:
 - **Affected Tracks** ripples only the track(s) where you performed the edit.
 - **Affected Tracks, Bus Tracks, Markers, and Regions** ripples the track(s) where you performed the edit and ripples any keyframes or envelopes on those tracks. This command also ripples any markers, regions, CD layout markers, and command markers in the project.
 - **All Tracks, Markers, and Regions** ripples all tracks and all keyframes and envelopes on those tracks. This command also ripples any markers, regions, CD layout markers, and command markers in the project.
2. Perform one of edits discussed above. Above the timeline, an arrow indicates where the post-edit ripple will occur and the direction the affected events will move.
3. The timeline is rippled after the edit according to the ripple type you choose.



Shuffling events

A quick way to change the order of a sequence of events in a track is provided. Right-click and drag an event to a new location in the track and choose **Shuffle Events** from the shortcut menu that appears. The events are shuffled into the new order.

The original four events

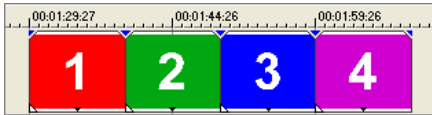

Right-click and drag event three between events one and two

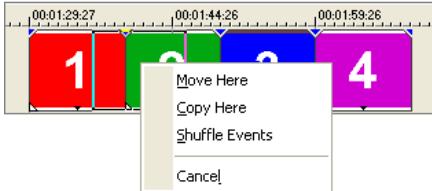

The four events after the shuffle

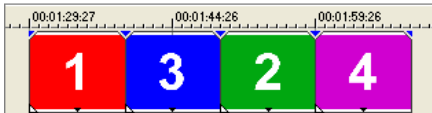

Crossfading events

You are allowed to crossfade between two events on the same track. For audio events, crossfading fades out one audio event's volume while another event's volume fades in. For video events, crossfading creates a transition between two events, one fading out while the other fades in. Lines appear indicating how and when the event's volume or transparency is being affected.

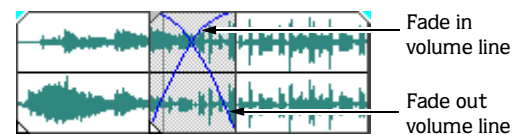

Using automatic crossfades

The automatic crossfade feature turns the overlapping portions of two events into a smooth crossfade. This feature is turned on as a default. Click the Automatic Crossfades button () or press **Ctrl+Shift+X** to turn automatic crossfades on and off.

Events before crossfade

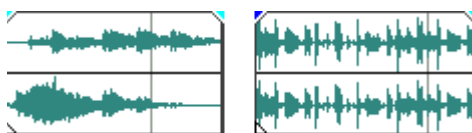

Events after crossfade

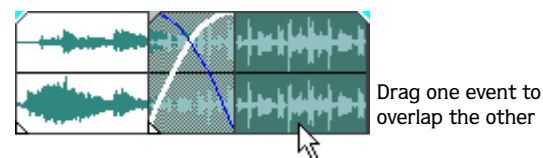

An option is provided for creating automatic crossfades when you add multiple media files to a track. For more information, see [Automatically crossfading inserted events](#) on page 47.

Manually setting a crossfade

An automatic crossfade is not inserted if a shorter event is placed on top of and within the same time frame of a longer event. In this case, the longer event begins playing, then the shorter event plays, and then the longer event resumes playing at the timeline position. You can manually create a crossfade to fade in and out of the shorter event.

1. Place the mouse pointer on one of the shorter event's handles. The envelope cursor appears (+↔).
2. Drag the handle to the desired position.

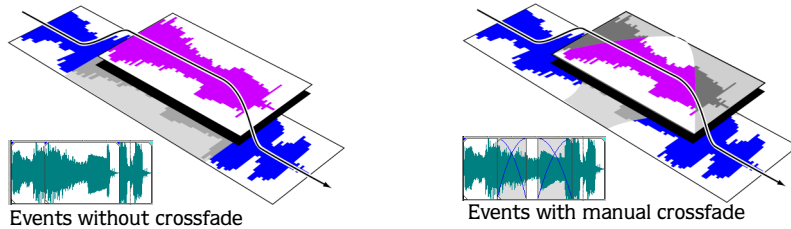

This is a fast and effective method of inserting a voiceover on top of a background music track (although the music fades out completely) or to replace a bad section of audio. For more information, see [Punching-in and crossfading events](#) on page 66.

Changing crossfade curves

You can change the crossfade curves that are used to fade in and out between two events.

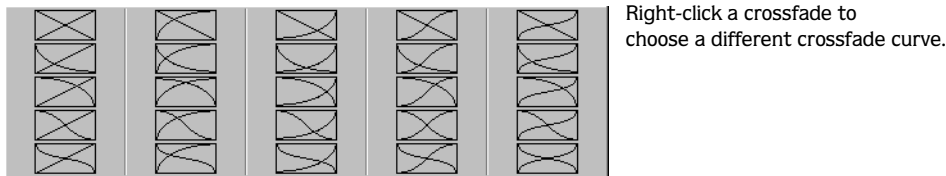

1. Right-click anywhere in the crossfade region to display a shortcut menu.
2. From the shortcut menu, choose **Fade Type**, and choose the desired fade type from the submenu.

Tip: If you use the same crossfade curve frequently, you can set it as a default for all new audio or video crossfades. For more information, see [Editing tab](#) on page 299.

Sliding a crossfade

You can slide a crossfade between two events without affecting the total length of the two overlapping events. This process is similar to sliding and slipping events. For more information, see [Slipping and sliding events](#) on page 71.

Press **Ctrl** + **Alt** while dragging the overlapping area between two events. The slide crossfade cursor appears (↔↔).

As you drag, the relative position of the media remains fixed on the track, and the crossfade position changes, effectively trimming the edge of the event in the direction you drag. You can use this technique when you want to maintain the length of two combined events but want the transition to occur earlier or later.

Two events with a crossfade.



Sliding the crossfade to the left...



...and to the right.

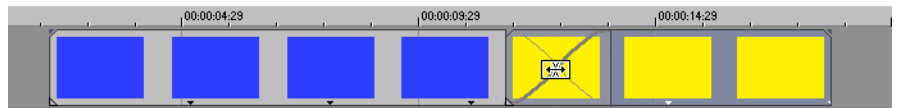

Using undo and redo

You are given unlimited undo and redo functionality while working on your project, even to the extent of being able to undo changes made before the last time a project was saved (but not closed). While you are working with a project, an undo history of the changes that you have performed is created. Each time you undo something, that change is placed in the redo history.

When you close the project or exit the software, both the undo and redo histories are cleared.

Using undo

Pressing **Ctrl**+**Z** or clicking the Undo button (↶) reverses the last edit performed. Repeatedly using the keyboard command or toolbar button continues undoing edits in reverse order, from most recent to oldest. In addition, you may undo the last edit by choosing it from the **Edit** menu.

Undoing a series of edits

You can undo a series of edits by using the drop-down list on the Undo button.

1. Click the arrow to the right of the Undo button (↶).
2. From the drop-down list, choose the edit that you want to undo. Items above it (subsequent edits) are selected automatically. Your project is restored to the state prior to those edits.

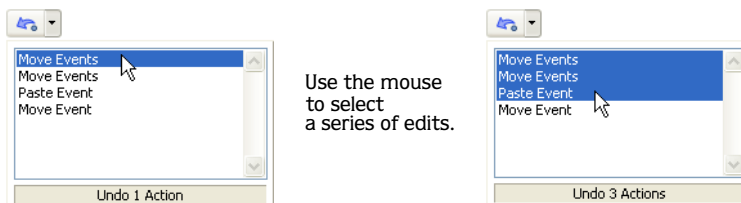

When you undo an edit or a series of edits, they are added to the redo history. This feature allows you to restore your project to a previous state.

Tip: From the **Edit** menu, choose **Undo All** to undo all edits in the history. All edits are undone and added to the redo history.

Using redo

Pressing **Ctrl** + **Shift** + **Z** or clicking the Redo button () redoes the last undo performed. Repeatedly using the keyboard command or toolbar button continues redoing undos in reverse order, from most recent to oldest. In addition, you may redo the last edit by choosing it from the **Edit** menu.

Redoing a series of edits

You can view the redo history by clicking the arrow on the right side of the Redo button (). The top item in the list that appears is the most recent undo edit. If you redo a specific edit that appears farther down the list, all subsequent edits above it are redone as well.

When you redo an edit or a series of edits, they are added to the undo history again. The redo history is cleared when a new edit is performed.

Clearing the edit history

You can clear both undo and redo histories without closing your project or exiting the software. Once the histories have been cleared, a new edit history is created as you continue working on the project. While clearing the edit history is not usually necessary, it can free up disk space. To clear the edit history, choose **Clear Edit History** from the **Edit** menu.

Adding project markers and regions

Several types of project markers are provided that identify parts of your project, serve as cues, and provide additional functionality:

- **Markers** are points that you mark along the project's timeline. They are typically used to mark locations in the project for later reference or to mark timing cues.
- **Regions** are ranges of time that you mark along the timeline. Regions identify ranges of time for your reference and can function as permanent time selections.
- **Command markers** are markers that enable metadata in streaming media files. These markers can be used to display headlines or closed captions, link to Web sites, or perform any other function you define. *For more information, see [Adding closed captioning to Windows Media Video \(WMV\) files on page 193](#).* In addition, these markers can be used to embed Scott Studios data information, which is used extensively in broadcasting.
- **CD layout markers** are markers that indicate tracks and indices for an audio CD layout. These marks are used to create tracks and index points when burning an audio CD. *For more information, see [Understanding tracks and indices on page 305](#).*

Tip: You can use ripple editing to automatically move markers and regions as you edit in the timeline. For more information, see [Applying post-edit ripples on page 73](#).

Working with markers

Markers are useful for identifying and navigating to specific locations in longer projects. As you place markers in your project, they are automatically numbered (up to 99) in the order that they are placed. Markers appear as orange tags above the ruler. You may name them and reposition them along the project's timeline.

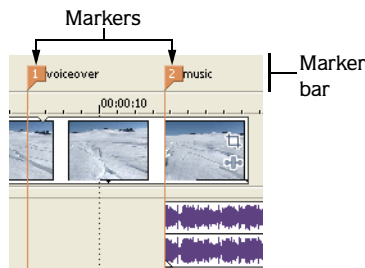

Right-click the marker bar

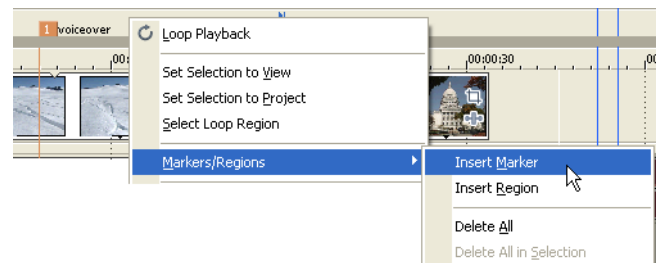

Inserting a marker at the cursor

1. Position the cursor where you want to place the marker.
2. From the **Insert** menu, choose **Marker**, or press **[M]**.
3. Type a name for the marker and press **[Enter]**. If you do not want to name the marker, simply press **[Enter]**.

Inserting a marker during playback

During playback, press **[M]**. The marker appears on the marker bar. You may name the marker after it has been set.

Naming (or renaming) a marker

1. Place the mouse pointer on the marker you want to name or rename. The pointer changes to a hand icon (⤴).
2. Right-click to display a shortcut menu.
3. From the shortcut menu, choose **Rename**. A text box opens next to the marker.
4. Type the marker name.
5. Press **[Enter]** to set the marker's name.

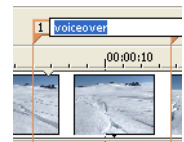

You can also double-click an existing name or double-click the space just to the right of a marker to rename it.

Moving markers

You can reposition a marker by dragging it on the marker bar.

Navigating to markers

You can jump the cursor to any marker on the timeline by clicking the marker. You can also jump to a marker by pressing the number keys along the top of the keyboard (not the numeric keypad).

Tip: Jump the cursor to the next or previous marker by pressing **[Ctrl] + [→]** or **[Ctrl] + [←]**.

Deleting markers

1. Place the mouse pointer on the marker that you want to delete. The pointer changes to a hand (☞).
2. Right-click to display a shortcut menu.
3. From the shortcut menu, choose **Delete**. The marker is removed from your project.

The tags are not renumbered as you remove them. For example, if you have five markers in your project and delete markers 3 and 4, the remaining markers will be listed as 1, 2 and 5. However, as you add markers again, Vegas software begins numbering the missing sequence first, in this case 3 and 4, then 6, 7, 8, etc.

Deleting all markers and regions

1. Right-click the marker bar.
2. From the shortcut menu, choose **Markers/Regions**, and choose **Delete All** from the submenu.

Working with regions

Regions identify ranges of time and provide a way to subdivide your project. A region is defined as the area between two region markers that share the same number. Regions can function as semi-permanent time selections. You can view region information in the Explorer by clicking the arrow next to the **View** button (☰) and selecting **Region View**.

Inserting regions

1. Make a time selection. *For more information, see [Selecting a time range](#) on page 61.*
2. From the **Insert** menu, choose **Region**, or press **[R]**.
3. Type a name for the region and press **[Enter]**. If you do not want to name the region, simply press **[Enter]**.

Region markers display at the beginning and end points of a time selection.

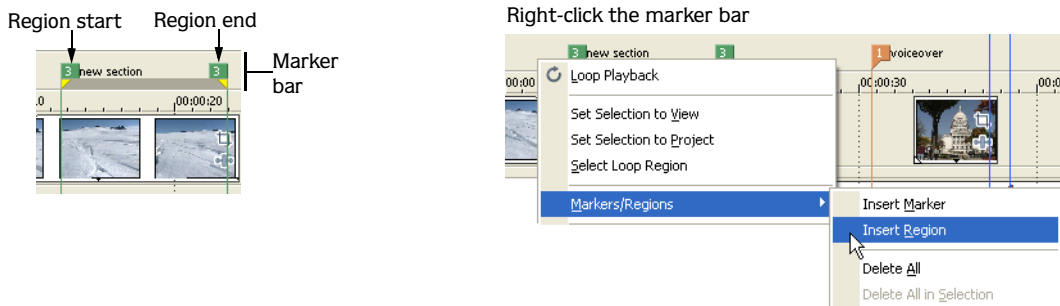

Moving regions

Drag a region marker to reposition it. To move both region markers (start and end markers) at once, hold **[Alt]** while dragging a region marker.

Naming regions

1. Place the mouse pointer on the left region marker you want to name or rename. The pointer changes to a hand icon (☞).
2. Right-click to display a shortcut menu.
3. From the shortcut menu, choose **Rename**. A text box appears next to the region marker.
4. Type the region's name.
5. Press **Enter** or click anywhere in the track view to set the name.

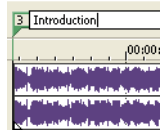

Selecting regions

You may select the events, across all tracks, within the region for editing or playing back.

1. Right-click one of the region markers to display a shortcut menu.

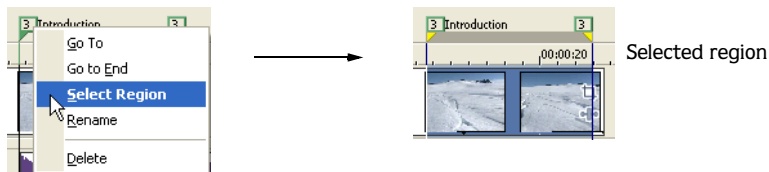

2. From the shortcut menu, choose **Select Region**.

Tip: You can also select a region by pressing a number on your keyboard (not the numeric keypad) or by double-clicking a region marker.

Navigating to regions

You can move the cursor to the start or end of a region by clicking either region marker. You may press **Ctrl** + **→** or **Ctrl** + **←** to move the cursor to the next or previous region markers.

Right-click a region marker to display a shortcut menu that allows you to navigate to the beginning (**Go to Start**) or the end (**Go to End**) of a region.

Deleting regions

1. Place the mouse pointer on the region marker's starting or ending point. The pointer changes to a hand icon (☞).
2. Right-click to display a shortcut menu.
3. From the shortcut menu, choose **Delete**. The region is removed from your project.

The tags are not renumbered as you remove them. For example, if you have five regions in your project and delete region 3 and 4, the remaining regions are listed at 1, 2 and 5. However, as you add regions again, Vegas software begins numbering the missing sequence first, in this case 3 and 4, and then 6, 7, 8, etc.

Deleting all regions and markers

1. Right-click the marker bar.
2. From the shortcut menu, choose **Markers/Regions**, and choose **Delete All** from the submenu.

Working with command markers

Command markers add interactivity to a multimedia presentation streamed over the Internet by inserting metadata into streaming media files. As your video plays, any number of other actions can be programmed to occur. These commands are a part of the Microsoft® Windows Media® and RealMedia® streaming formats. Most frequently, these actions add text or open a related Web site where the viewer can find more information about the topic at hand. The specific commands available vary depending on the final format of your project.

Note: *Windows Media Player 9 will ignore metadata commands unless the Run script commands when present check box is selected on the Security tab of the player's Preferences dialog. Be sure to instruct your audience to select this check box before playing your file.*

You can use command markers to add closed captions to your project. *For more information, see [Adding closed captioning to Windows Media Video \(WMV\) files](#) on page 193.*

Command markers can also indicate when an instruction (function) will occur in a WAV file being used in a radio broadcast environment (Scott Studios data). The following two sections define the markers for both streaming media and Scott Studios files.

Note: *While streaming media files can be played on any hard drive or CD-ROM, they require a special streaming media server (provided by your Internet service provider) to stream properly across the Internet.*

Defining streaming media commands

In a streaming media file, command markers can be used to display headlines, show captions, link to Web sites, or any other function you define. Several command types are included that you may add to a streaming media file. Some command types are exclusive to either the Windows Media or the RealMedia player.

Command	Player type	Description
URL	Windows Media and RealMedia	Indicates when an instruction is sent to the user's internet browser to change the content being displayed. With this command, you enter the URL that displays at a specific time during the rendered project's playback.
Text	Windows Media	Displays text in the captioning area of the Windows Media Player located below the video display area. You enter the text that will display during playback. Note: To view captions during playback in Windows Media Player 9, choose Captions and Subtitles from the Windows Media Player Play menu, and then choose On if Available from the submenu.
WMClosedCaption	Windows Media	Displays the entered text in the captioning window that is defined by an HTML layout file.
WMTextBodyText	Window Media	Displays the entered text in the text window that is defined by an HTML layout file.
WMTextHeadline	Windows Media	Displays the entered text in the headline window that is defined by an HTML layout file.
Title	RealMedia	Displays the entered text on the RealPlayer's title bar. Note: When rendering Windows Media files, title information is based on the settings on the Summary tab of the Project Properties dialog or the Index/Summary tab of the Custom Template dialog. The summary information from the Project Properties dialog will be used if information has been specified in both places. To view this information during playback, choose Now Playing Options from the Windows Media Player View menu and select the items you want to display.
Author	RealMedia	Displays the entered text (Author's name) when a user selects About This Presentation from the RealPlayer's shortcut menu. Note: When rendering Windows Media files, author information is based on the settings on the Summary tab of the Project Properties dialog or the Index/Summary tab of the Custom Template dialog. The summary information from the Project Properties dialog will be used if information has been specified in both places. To view this information during playback, choose Now Playing Options from the Windows Media Player View menu and select the items you want to display.
Copyright	RealMedia	Displays the entered copyright information when a user selects About This Presentation from the RealPlayer's shortcut menu. Note: When rendering Windows Media files, copyright information is based on the settings on the Summary tab of the Project Properties dialog or the Index/Summary tab of the Custom Template dialog. The summary information from the Project Properties dialog will be used if information has been specified in both places. To view this information during playback, choose Now Playing Options from the Windows Media Player View menu and select the items you want to display.
HotSpotPlay	RealMedia	Displays the RealMedia file specified in the Parameter box when users click the RealPlayer video display.
HotSpotBrowse	RealMedia	Displays the Web page specified in the Parameter box when users click the RealPlayer video display.
HotSpotSeek	RealMedia	Jumps to the time specified in the Parameter box when users click the RealPlayer video display.

Defining Scott Studios data commands

For WAV files using Scott Studios data, command markers can be used to define information about the WAV file.

Command	Description
SCOTT EOM	Calculates when the next queued clip starts playing in a Scott Studios system. For more information, please refer to your Scott Studios documentation.
SCOTT Cue In	Set the beginning of a file in a Scott Studios System without performing destructive editing. For more information, please refer to your Scott Studios documentation.

Inserting command markers

Command markers appear as blue tags on the command bar, which is above the marker bar.

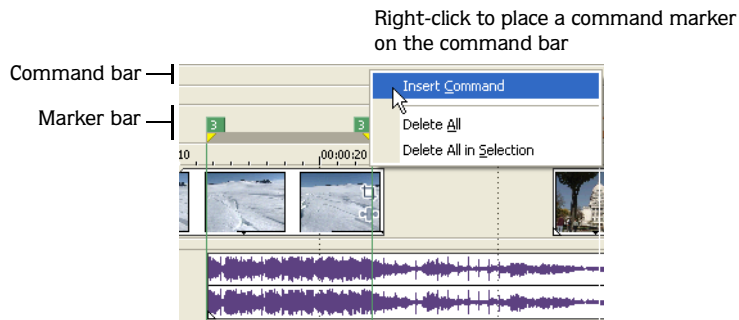

1. Position the cursor where you want to place the command marker.
2. From the **Insert** menu, choose **Command**, or press **[C]**.
3. Complete the Command Properties dialog:

- If desired, choose a custom template from the Template drop-down list. *For more information, see [Saving command properties as a custom template](#) on page 84.*
- Choose the type of command from the Command drop-down list.
- In the Parameter box, enter parameters to define the behavior of the command.
- Enter your own notes or comments in the Comments box.
- Specify the timing of the command in the Position box. Otherwise, command markers are automatically set to the current cursor position.

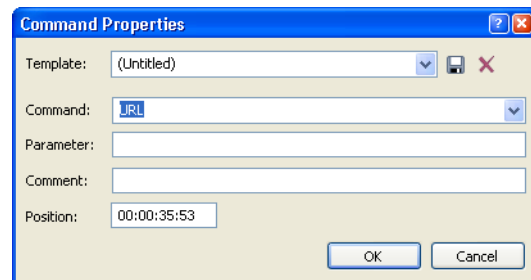

4. Click OK. The new command marker appears on the command bar.

Editing command properties

Double-click any command marker to open the Command Properties dialog and edit its contents. You can also right-click a command marker and choose **Edit** from the shortcut menu.

Saving command properties as a custom template

If you plan to use a command more than once, you can save command properties as a template. You can then reuse the command properties by choosing the template from the Template drop-down list.

1. Create a command and complete the Command Properties dialog.
2. Enter a name for the template in the Template box.
3. Click the Save Template button ().

Note: Your metadata command templates are saved in the `cmdtemp.xml` file in the program folder. You can edit this file directly to modify your templates.

Deleting command markers

1. Place the mouse pointer on the command marker. The pointer changes to a hand icon (☞).
2. Right-click to display a shortcut menu.
3. From the shortcut menu, choose **Delete**. The command marker is removed from your project.

Working with CD layout markers

Markers on the CD layout bar indicate the locations of tracks and indices in an audio CD layout project. These markers are discussed in a later chapter. *For more information, see [Understanding tracks and indices on page 305](#).*

Working with the marker tool

You can use the marker tool to navigate the marker bars and edit multiple selected markers.

1. Click the **Marker Tool** button  in the top-right corner of the timeline.
2. Select the markers you want to edit:
 - Press the Left Arrow/Right Arrow keys to move to the previous/next marker in the active bar (marker/region bar, CD layout bar, or command bar).
 - Press Shift+Left Arrow/Right Arrow keys to extend the selection to the previous/next marker.
 - Press Shift while clicking two marker tags to select all markers between the two tags.
 - Press Ctrl while clicking marker tags to select or deselect individual markers.
3. Edit your markers:
 - Dragging any selected marker will move all selected markers in the active bar as a group.
 - Pressing Delete will remove all selected markers in the active bar.

The marker tool is inactive when you change focus to another portion of the Vegas window.

Using an external audio editing program

Vegas software is a nondestructive editing environment, which means that the original source files remain unchanged by any editing done in the software. Destructive (constructive) edits that modify the actual source media file may be done in a separate application such as Sound Forge® software from Sony Pictures Digital. By setting up a separate audio editor, you can quickly access the program from Vegas software via the **Tools** menu or by pressing **Ctrl** + **E**.

Setting up an audio editing program

If you already have Sound Forge software loaded on your computer when you installed Vegas software, the installation should have detected it and made it your default audio editing program. However, if you do not have Sound Forge software or want to specify a different audio editor, you may do so in the Preferences dialog.

1. From the **Options** menu, choose **Preferences**. The Preferences dialog appears.
2. In the Preferences dialog, click the **Audio** tab.
3. Click the **Browse** button to the right of the Preferred audio editor box. The Preferred Audio Editor dialog appears.
4. From this dialog, navigate to the application to use for editing audio files.
5. Select the application's executable icon (.exe) and click **Open** to set the application as your default audio editor.

The application's path displays in the Preferred audio editor box.

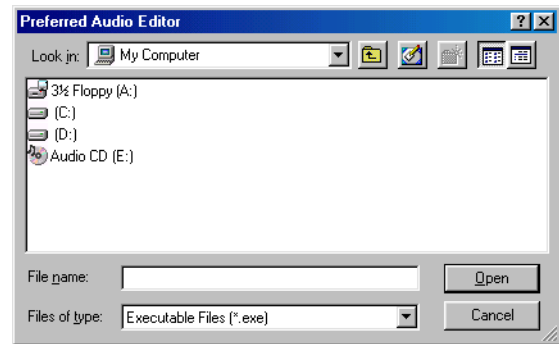

Opening an audio editor from Vegas software

All events in your project are references to media files on a storage device. When you edit an audio event in an audio editor, you can choose to open the original media file or a copy of the file.

Opening a file in an audio editor

You can directly edit the media file to which an audio event is referenced. Any changes you make and save in the audio editor are permanent and are reflected in the event in your project.

1. Select the event to be edited.
2. From the **Tools** menu, choose **Audio**, and choose **Open in Audio Editor** from the submenu.

Your selected audio editing application opens the event's referenced media file. Make the necessary changes and save the file in the audio editor. If you keep the media file's name and location the same, its event is updated immediately in your project. However, if you change the media file's name or location (by using **Save As**), you must import the edited (new) file into Vegas software.

Opening a copy of a file in an audio editor

You can also create a copy of an audio file and open it in an audio editor. Opening a copy of a file has the advantage of preserving the original file unchanged. The modified copy is inserted into the event as a take and is automatically added to the Media Pool.

1. Select the event to be edited.
2. From the **Tools** menu, choose **Audio**, and choose **Open Copy in Audio Editor** from the submenu.

When you are finished editing, save the file. "Take X" is added to the end of the filename to distinguish it from the original and adds it to the project as a take. If you save it to a new file (by using **Save As**), you must manually add it as a take into the project. *For more information, see [Working with takes](#) on page 94.*

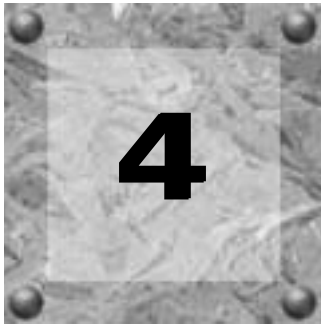

Advanced Editing Techniques

This chapter builds on the techniques that were introduced in the last chapter. Ripple editing, pitch shifting, and takes are just three of the more advanced editing topics that are covered in this chapter.

Snapping events

Vegas® software is preset to snap events into place as you drag them. Events can snap to another event's edges, to the cursor position, or to a time selection. Events are allowed to snap to grid lines and markers. As you move an event along the timeline, its edge automatically aligns to designated snap points. At the highest level, all features can quantize to individual frames.

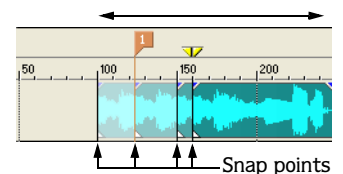

Turning snapping on and off

You can quickly turn snapping on and off by clicking the Enable Snapping button (). You can also selectively turn snapping options on and off in the **Options** menu:

- **Enable Snapping** controls all snapping behavior except quantizing to frames.
- **Snap To Grid** controls snapping to grid markers. A variety of grid measurements are provided. *For more information, see [Changing grid spacing](#) on page 289.*
- **Snap To Markers** controls snapping to markers. This command applies to markers, regions, command markers, and CD layout markers. *For more information, see [Adding project markers and regions](#) on page 78.*

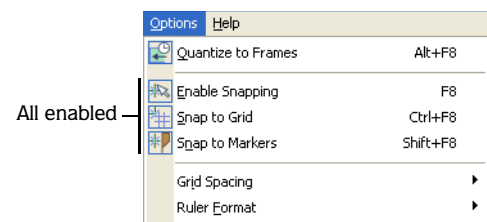

Quantizing to frames

The Quantize To Frames command in the **Options** menu takes snapping one step further. With this feature enabled, *everything* snaps to the starting edge of individual project frames. Quantizing affects how you can move events, place markers, make selections, and position the cursor.

Quantizing to frames means that the position of markers, regions, events, and the cursor are limited to the start of an individual video frame.



Track zoomed in so that one thumbnail = one frame

Using the event snap offset

Each event in your project has a snap offset flag that can be moved along the length of the event. The flag is the white triangle that is located in the lower-left corner of each event. This flag allows you to designate where snapping occurs. This is useful if you need to align the snap with a beat in the event instead of the edge.

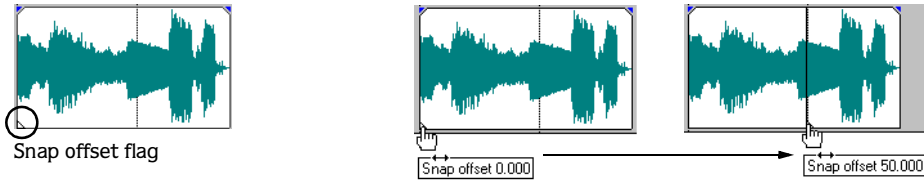

1. Place the mouse pointer on the snap offset triangle. The pointer changes to a hand icon (☞).
2. Drag the snap offset flag to the new position in the event. As the flag moves, a time display appears. This time display indicates where the snap offset flag occurs in time in the event.
3. Release the mouse to set the snap offset flag.

Snapping to the cursor or a selection

You can snap two clips in the same track end-to-end, but how can you snap two events on separate tracks? You can easily snap to specific event boundaries in any track by making a time selection for the event.

1. Double-click the event you want to snap to. The time selection area on the ruler sets to the length of the event.
2. Drag another clip in a different track near the end of the first clip. It snaps into position.

In this example, the second event snaps to the edge of the time selection. Because events also snap to the cursor, you could accomplish the same task by pressing **Ctrl** + **Alt** + **→** or **Ctrl** + **Alt** + **←** to position the cursor on the edge of the first event. Once the cursor is on the event edge, you can snap the second event to the cursor.

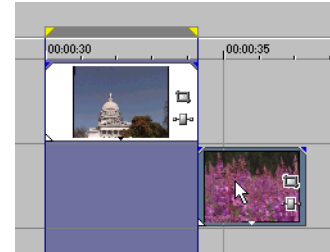

Pitch shifting audio events

 *Pitch shifting while preserving length is only available in the full version of Vegas software.*

A pitch shift is a way to raise or lower the pitch of an audio event. The semitone range is -24 to 24. Twelve semitones equal one octave, so you may increase or decrease the pitch of an event within a two-octave range. Within each semitone is a finer pitch adjustment called cents. There are one hundred cents in one semitone.

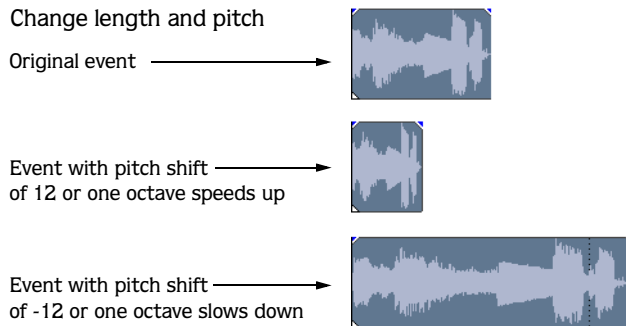

Editing from the timeline

1. Select an event.
2. Use the = and - keys on your keyboard (not the numeric keypad) to adjust pitch:

Key	Result
=	Raise pitch one semitone.
Ctrl+=	Raise pitch one cent.
Shift+=	Raise pitch one octave.
Ctrl+Shift+=	Reset pitch.
-	Lower pitch one semitone.
Ctrl+ -	Lower pitch one cent.
Shift+ -	Lower pitch one octave.
Ctrl+Shift+ -	Reset pitch.

If the Show active take information in events check box is selected on the General tab of the Preferences dialog, the event's pitch shift is displayed in the bottom-left corner of the event. If the media has a known root note, the new root is displayed in parentheses:

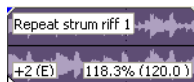

Editing in the Event Properties dialog

1. Right-click the event and choose **Properties** from the shortcut menu.
2. On the Audio Event tab, choose a setting from the Method drop-down list to specify how you want to pitch-shift the event, or choose **None** if you want to preserve the event pitch.

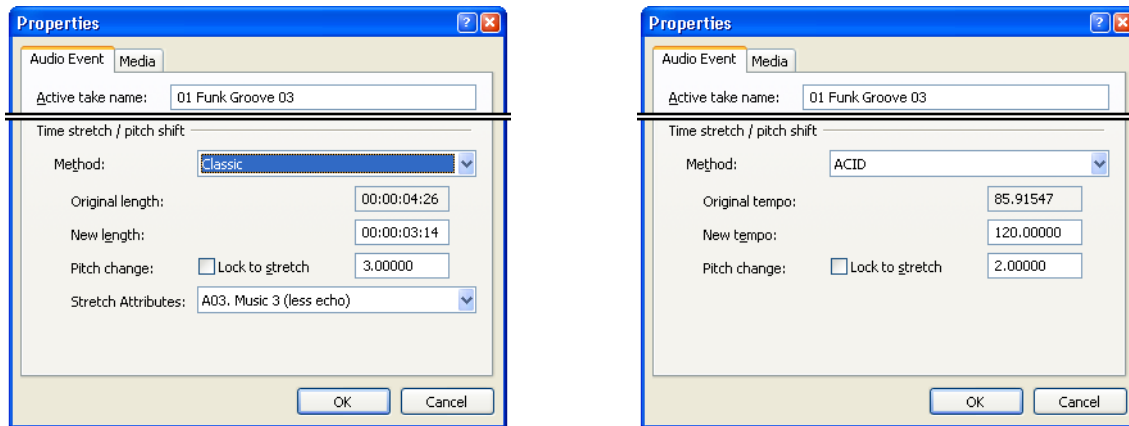

3. If you selected **Classic** from the Method drop-down list, indicate the new event length and amount of pitch shifting you want to apply:
 - a. Type the desired event length in the New length box.
 - b. Type the desired pitch shift (in semitones) in the Pitch change box.

If you want to change the event length without changing pitch, type 0 in the box.

If you want the pitch to be determined by the amount of time stretching, select the Lock to stretch box. For example, doubling an event's length will raise its pitch by one octave.

- c. Choose a setting from the Stretch Attributes drop-down list to specify how you want to divide and crossfade the file to prevent artifacts. Depending on your source material, you may need to experiment with different crossfade types.
4. If you selected **ACID** from the Method drop-down list, indicate the new event tempo and the amount of pitch shifting you want to apply:
 - a. Type the desired event length in the New tempo box.
 - b. Type the desired pitch shift (in semitones) in the Pitch change box.

If you want to change the event length without changing pitch, type 0 in the box.

If you want the pitch to be determined by the new event tempo, select the Lock to stretch box. For example, doubling an event's tempo will raise its pitch by one octave.

5. Click **OK**.

Time compressing/stretching events

 *Time compressing/stretching audio while maintaining pitch is only available in the full version of Vegas software.*

Time stretching and compressing events is the process of using the same amount of source media to fill a shorter or longer event. While this can be done to both video and audio events, the two cases are fundamentally different.

Press **[Ctrl]** and drag the edge of the event toward the center of the event to compress (shorten) it or drag the edge out away from the center to stretch (lengthen) it.

You can see the results of the time compression or stretching by viewing the properties of the event. Right-click the event and choose **Properties** from the shortcut menu. Time compressing/stretching an audio event affects the Time stretch/pitch shift settings, while Time compressing/stretching a video event affects the Playback rate setting.

Tip: You can time compress/stretch several events at once by grouping them first. You can also apply a ripple edit after time compressing or stretching events. For more information, see [Grouping events](#) on page 141 or [Applying post-edit ripples](#) on page 73.

Time compressing/stretching video

Time stretching video allows you to fill a given duration with a set amount of actual video, sometimes called fit-to-fill. For example, if you have a five-second video event and you want this event to fill an eight-second slot, press **[Ctrl]** and drag the edge of the event to eight seconds. The resulting video is in slow motion, but the contents (footage) remain the same. If you had used a velocity envelope to slow the video to the same rate, the event would also be in slow motion, but its duration would remain unchanged at five seconds. Stretched video has a zigzag line between thumbnails. Video can also be compressed (sped up and shortened in length) by using this method.



When stretching video events or slowing video down, a set number of frames are extended across a period of time. For example, if you take source footage at 30 frames in a second and slow it so that only 15 source frames run during that same second, an additional 15 frames must be created to maintain the project's 30 fps frame rate. Simply duplicating frames is the easiest way to do this. A more sophisticated method is to resample the frames of an event, allowing Vegas software to interpolate and redraw these intervening frames. For more information, see [Resample \(video only\)](#) on page 135 and [Resampling video](#) on page 197.

Working with takes

A take is a version of a scene or audio recording, as in “Scene 10, Take 7”, which means the seventh time that scene number ten has been shot. A number of takes can be included in the same location (event) of the project. You can then rapidly switch between these separate takes to see which one fits into the project the best. Although this is what takes are designed for, you can actually use any media files you want as a take, even completely different sounds or scenes. Since an event is just a container of a specific length and at a specific location, the actual content (media file) is easily changed.

Adding takes

You can add multiple media files to the timeline at the same time to a single event as takes. You can also add regions within media files as takes. *For more information, see [Adding regions as takes](#) on page 99.*

Adding media files to the timeline as takes

1. Locate the media files that you want to insert as takes in the Explorer and select them. Select a range by pressing **[Shift]** and clicking the first and last file in the range, or select nonadjacent files by pressing **[Ctrl]** and clicking the various clips individually.
2. Right-click and drag one of the selected clips in the group to the timeline.
3. From the shortcut menu, choose **Add as Takes**.

Tip: To add either just the audio or just the video portions of files as takes, choose **Video Only: Add Video as Takes** or **Audio Only: Add Audio as Takes** from the shortcut menu.

Adding takes to existing events

You can add media files to existing events as takes.

1. Right-click a media file in the Explorer and drag it to an existing event.
2. From the shortcut menu, choose **Add as Takes**.

Selecting takes

When you add an event with multiple takes, a single event is inserted into a track. The length of the event is set according to the last clip that was selected. This last clip is set as the active take.

1. Right-click an event with multiple takes.
2. From the shortcut menu, choose **Take**, and choose **Next Take** or **Previous Take** from the submenu. Alternately, choose the name of the take from the list at the bottom of the submenu.

Tip: Click an event and press **[T]** to select the next take or **[Shift] + [T]** to select the previous take.

Previewing and selecting takes

You can preview the takes for a given event.

1. Select an event containing multiple takes.
2. Right-click to display a shortcut menu or, from the **Edit** menu, choose **Take** to display a submenu.
3. Choose **Choose Active...** from the submenu. The Take Chooser dialog appears.
4. Select the take that you want to preview and use the Play (▶) and Stop (■) buttons within the dialog.
5. To use a take, select it and click OK. The selected take is now the active take.

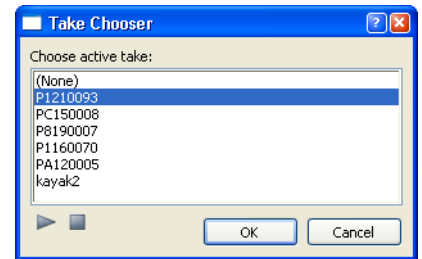

Deleting takes

You can delete individual takes from an event at any time.

1. Right-click an event with multiple takes.
2. From the shortcut menu, choose **Take**, and choose **Delete Active** from the submenu to immediately remove the active take. Alternately, choose **Delete** to open a dialog with a list of all of the takes contained in this event.

Working with take names

Displaying take names on events

Take names may be displayed on the events in the timeline.

1. From the **Options** menu, choose **Preferences**. The Preferences dialog appears.
2. On the General tab, select the Show active take information in events check box.
3. Click OK.

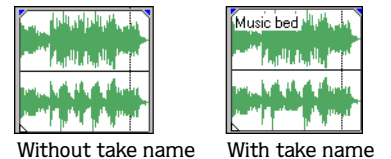

Changing take names

Changing the name of a take does not affect the source media file in any way. Typically, you may want to change an event's name after recording multiple takes into a track or event. *For more information, see [Working with multiple recorded takes](#) on page 170.*

1. Select the take to be renamed. *For more information, see [Selecting takes](#) on page 94.*
2. Right-click the event to display a shortcut menu.
3. From the shortcut menu, choose **Properties**. The Properties dialog opens.
4. Type the new name in the Active take name box.
5. Click OK to set the new take name.

Using the Trimmer window

The Trimmer allows you to work with and edit one media file at a time. The entire file is opened into the Trimmer, in contrast to events on the timeline that may only contain a portion of the actual source file.

The main function of the Trimmer window is to allow you to trim a media file and place portions of it on a track. You can also add regions and markers to a file, preview the media file, or open it in an external audio editing program.

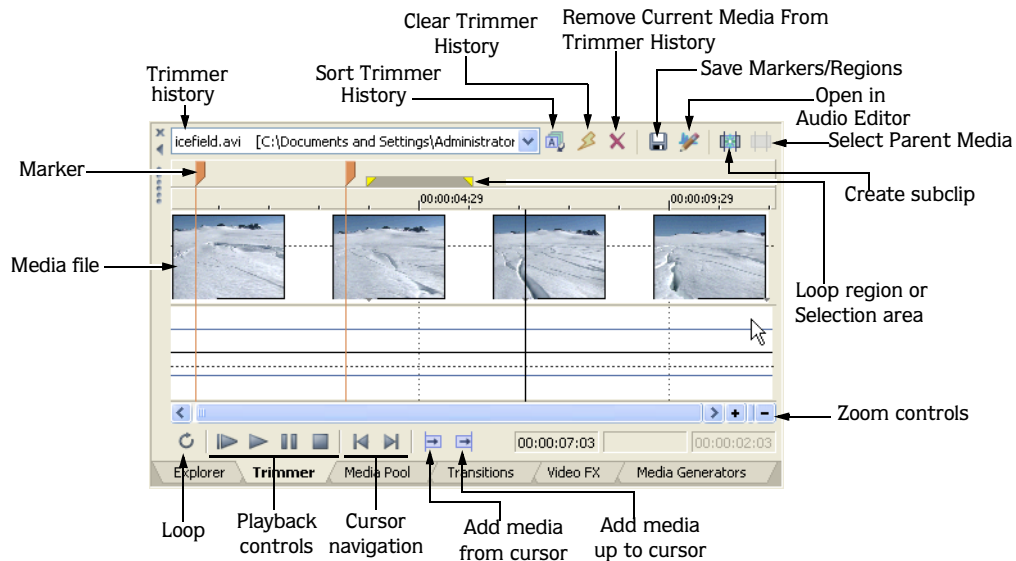

You can open any number of files in the Trimmer at the same time, selecting the one you currently want to work on from the Trimmer history drop-down list.

From the **View** menu, choose Trimmer or press **[Alt] + [2]** to display the Trimmer window, if it is not already visible. You can dock the Trimmer window in the window docking area or float it over the work area. For more information, see [Window docking area and floating window docks](#) on page 21.

Opening a file in the Trimmer

1. Right-click an event. A shortcut menu appears.
2. Choose **Open in Trimmer**.

You can also drag files to the Trimmer from the Explorer or the Media Pool.

Double-clicking a file to open it in the Trimmer

You can set the software to open a file in the Trimmer when you double-click the file in the Media Pool or Explorer windows.

1. From the **Options** menu, choose **Preferences**.
2. Click the **General** tab.
3. Choose **Double click on media file loads into Trimmer instead of tracks**.

Moving frame-by-frame in the Trimmer window

As you navigate through a video file in the Trimmer, the exact frame that the cursor is over in time is displayed as in a thumbnail image under the cursor. When using the left and right arrow keys, this allows you to edit with frame accuracy. Make sure Animate video frames in Trimmer is selected in the Preferences dialog to use this feature.

Making selections in the Trimmer

After you have opened a media file in the Trimmer, you may select a segment of it and place it in your project. Make a time selection to select a segment in the Trimmer in the same way you do in the project timeline. For more information, see [Selecting a time range](#) on page 61.

You can make a selection during playback by using the keyboard. Press **I** or **L** to mark the start of the selection, and press **O** or **R** to mark the end.

If you know the exact timecode of the point where you want to begin and end a time selection, you can enter it into the boxes at the lower right corner of the Trimmer window.

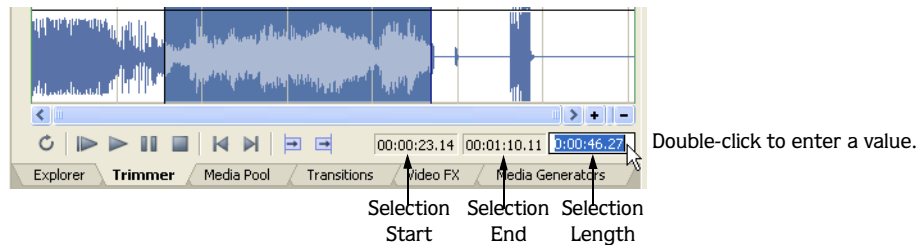



Tip: Press **Backspace** to recall the last five time selection areas in the Trimmer.

Adding selections to the timeline

You can use the Trimmer window to do traditional three-point and two-point editing. These editing techniques allow you to add smaller sections of files to the timeline.

Post-edit ripple mode affects how a selection is added to the timeline from the Trimmer. When the Auto Ripple button () is selected, adding a selection from the Trimmer selection affects the position of later events on the track. When not in post-edit ripple mode, adding a selection from the Trimmer has no effect on the position of other events. For more information, see [Editing events](#) on page 63.

Adding selections at the cursor

1. Open a media file in the Trimmer.
2. Make a time selection in the Trimmer.
3. Select the track in the timeline where the selection will be added.
4. Position the cursor in the timeline at either the start or end point where you want to add the selection.
5. Add the selection to the timeline in one of the following ways:
 - Click the Add Media from Cursor button () or press **[A]** to insert the event after the cursor.
 - Click the Add Media up to Cursor button () or press **[Shift] + [A]** to insert the event before the cursor.

Alternately, you can drag the selection from the Trimmer to the timeline

Note: *Post-edit rippling (if enabled) applies to clips inserted from the Trimmer. For more information, see [Editing events](#) on page 63.*

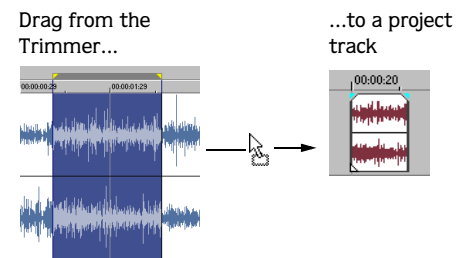

Filling a time selection on the timeline

You can select a range of time on the project timeline and then fill it with the same length selection from the Trimmer.

1. Create a time selection in the timeline where you want to add the event. This sets the duration and position of the event that you will create.
2. Open the media file you want to use to fill the time selection in the Trimmer window.
3. Right-click the file in the Trimmer window and choose **Sync Track View Selection Time from Cursor** or **Sync Track View Selection Time up to Cursor** from the shortcut menu. A time selection is created in the file in the Trimmer window to match the time selection in the timeline.
4. Adjust the location of the time selection in the Trimmer as needed by dragging the time selection (the area between the yellow triangles) on the Trimmer marker bar.
5. Drag the event from the Trimmer to the timeline and allow it to snap into place within the time selection.

Adding selections from a media file with audio and video

You can open a file in the Trimmer that has both audio and video streams (e.g., AVI). When you add a selection from this type of file to the timeline, both streams are added:

- If you select a video track before adding the selection, the video is added to the selected track and the associated audio is added to the track below it.
- If you select an audio track before adding the selection, the audio is added to the selected track and the associated video is added to the track above it.

New tracks are created for the added media if necessary.

Adding and saving regions and markers to a media file

The Trimmer allows you to add markers and regions to a media file in the same way that you add them to your project. Media file markers and regions are different from project markers and regions. The difference between the two is that project markers and regions affect a project, while media file markers and regions are embedded in, and saved with, a media file. *For more information, see [Adding project markers and regions](#) on page 78.*

The markers and regions you add in the Trimmer are only temporary. You must save them by clicking the Save button () in the Trimmer window if you want to use them again after you close the project. After the markers and regions are added and saved to the media file, they are available when you open the media file in an audio editor program or in the Trimmer.

Note: You cannot save markers to read-only media files. Change a file's properties to make the file writable before saving markers.

Automatically saving Trimmer markers and regions with media files

1. From the **Options** menu, choose **Preferences**.
2. On the General tab, select **Automatically save trimmer markers and regions with media file**.

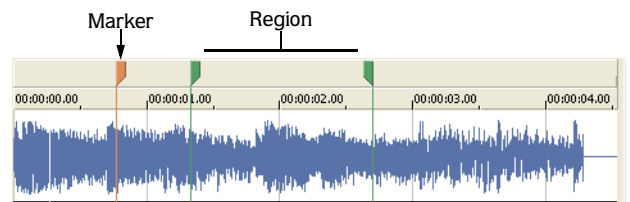

Adding regions as takes

Once regions are saved with a media file, either in the Trimmer window or in another application, you can add the regions as takes to the timeline from the Explorer window. In the Explorer window, click the arrow next to the View button and select **Region View** from the drop-down list. A single media file may contain a number of separate regions. You can select these regions individually or as groups and insert them as takes into the timeline. This is especially useful when loop-recording numerous takes to a single file. *For more information, see [Working with takes](#) on page 94.*

Viewing media markers and regions in events

From the **View** menu, choose **Event Media Markers** to toggle the display markers and regions that are saved in a media file. These markers are displayed in the timeline in events that refer to the media file.

Media markers and regions cannot be edited within the event. However, when you edit the markers in markers and regions in the Trimmer window or in an external audio editor, the event will reflect your changes.

Media markers in Trimmer

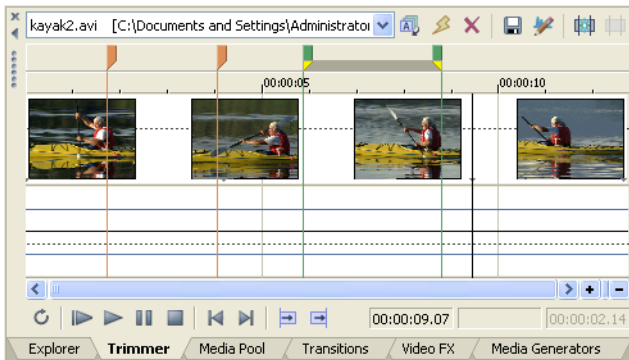

Media markers in event

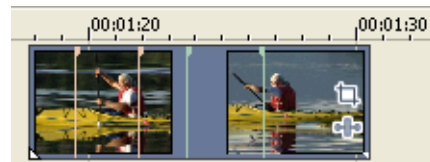

Tip: When media markers are displayed, you can use them as snap points for positioning the cursor and for edge-trimming if **Snap to Markers** is selected on the **Options** menu. If a media file's frame rate does not match your project frame rate, frame quantization will occur after the snap if **Quantize to Frames** is selected on the **Options** menu.

Opening a file in an external audio editor from the Trimmer

The Trimmer allows you to open your selected audio editing application (e.g., Sound Forge) to perform permanent edits to the media file. After you make the necessary changes and save the file in the audio editor, the event is automatically updated. Make sure that the media file's name and location remain the same. For more information, see [Using an external audio editing program](#) on page 85.

To open the audio editor from the Trimmer, click the Open in Audio Editor button ().

Creating a subclip

1. Create a selection in the Trimmer window.
2. Click the Create Subclip button  . The Create Subclip dialog is displayed.

Tip: You can also right-click an event in the timeline and choose **Create Subclip** from the shortcut menu.

3. In the Name box, type the name you want to use to identify the subclip in the Media Pool. For more information, see [Using the Media Pool](#) on page 41. By default, the file name is used with a subclip number appended.
4. Select the Reverse check box if you want the subclip to be played backward when you add it to your project.
5. Click OK to create the subclip. You can then create events from subclip via the Media Pool.

Selecting a subclip in its parent media

1. Right-click a subclip in the Media Pool and choose **Open in Trimmer** from the shortcut menu.
2. Click the Select Parent Media button  in the Trimmer window. The subclip's original media file is opened in the Trimmer, and the portion of the media that represents the subclip is selected.

Using the Edit Details window

The Edit Details window displays a database for all of the media in your project. It shows information about how the files are being used and allows you to modify many of those properties. You may sort, add or change information, rearrange columns, and edit items in the project.

This window provides an alternate method for working with events, audio CD track list items, command markers, markers, and regions after they are placed in your project.

You can dock the Edit Details window in the window docking area or float it on the workspace. *For more information, see [Window docking area and floating window docks](#) on page 21.*

Viewing the Edit Details window

To view the Edit Details window, choose **Edit Details** from the **View** menu or press **[Alt] + [4]**. The Show dropdown list allows you to view categorized project information. You can edit most entries by double-clicking them or by right-clicking them to display a shortcut menu.

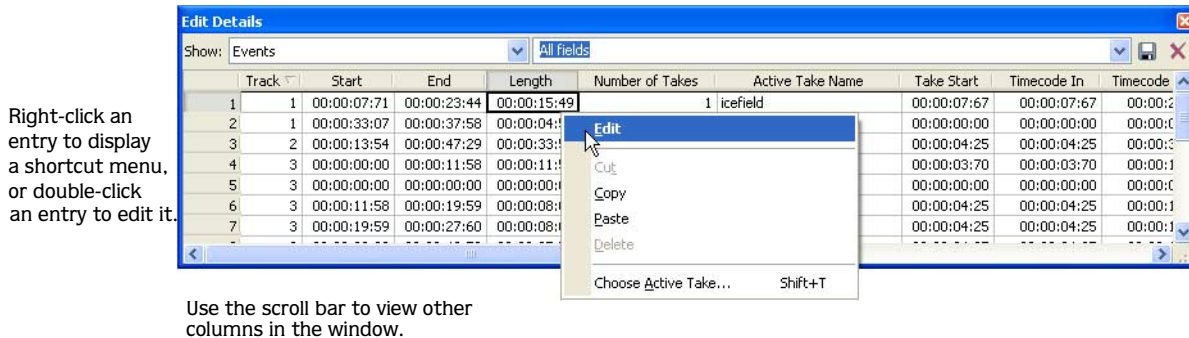

Right-click an entry to display a shortcut menu, or double-click an entry to edit it.

Use the scroll bar to view other columns in the window.

Audio CD track list

The Audio CD track list category displays information about the track and index markers placed on the CD layout bar. This information is used to burn audio CDs. *For more information, see [Understanding tracks and indices](#) on page 305.*

Commands

The Commands category displays information about commands that are placed along the project's timeline. This category displays four columns: the command's position along the timeline, the command type, its parameters, and any comments that were entered when the command marker was placed in your project. Right-click a command entry to display a shortcut menu. *For more information, see [Working with command markers](#) on page 82.*

Events

The **Events** category displays information about all of the events in your project. You may sort any of the information by clicking a column's header. The number of columns in the **Events** category requires that you use the scroll bar to view them all.

The following table explains each column in the **Events** category and describes its function.

Column	Description	Edit function
Track	Displays the track number where the event is located.	Move the event to a different location by entering a different track number (pg. 48).
Start	Displays when on the timeline the event starts playback.	Enter a different value to cause the event to begin playback sooner or later in the project (pg. 48).
End	Displays when on the timeline the event ends playback.	Enter a different value to cause the event to end playback sooner or later in the project (pg. 48).
Length	Displays the total length of the event.	Enter a different value to increase or decrease the event's playback time.
Number of Takes	Displays the amount of recorded takes contained in the event.	Cannot be edited (display only).
Active Take Name	Displays the event's current take name.	Enter a different name for the current take (pg. 95).
Take Start	Displays the offset into the source media file when the placed event begins playback.	Enter a different value to cause the take to playback sooner or later from the source media file.
Timecode In	Displays the media file timecode at the start of the event.	Display only (cannot be edited).
Timecode Out	Displays the media file timecode at the end of the event.	Display only (cannot be edited).
File Path	Displays the path of the event's media file.	Enter a new media file reference path for the event to use.
Tape Name	Displays the name of the source media tape name.	Change the tape name here or in the properties dialog for the media file (pg. 202).
Select	Displays whether the event is selected in the project.	Toggle the event's selection by clicking the check box. A check mark in the box indicates that the event is selected (pg. 60).
Mute	Displays whether the event is muted.	Toggle the event's mute switch by clicking the check box. A check mark in the box indicates that the event is muted (pg. 133).
Loop	Displays whether the event is looped for playback.	Toggle the event's loop switch by clicking the check box. A check mark in the box indicates that the event is looped for playback (pg. 133).
Lock	Displays whether the event is locked.	Toggle the event's lock switch by clicking the check box. A check mark in the box indicates that the event is locked (pg. 133).
Normalize	Displays whether the event is normalized.	Toggle the event's normalize switch by clicking the check box. A check mark in the box indicates that the event is normalized (pg. 134).
Snap Offset	Displays when in the event the snap offset is positioned.	Enter a different value to change the snap offset position in the event (pg. 90).

Markers

The **Markers** category displays information about markers on the project's timeline. This category displays two columns: the marker's position on the timeline and the marker's name. *For more information, see [Working with markers](#) on page 79.*

Regions

The **Regions** category displays information about regions on the project's timeline. This category displays four columns: the region's start position, end position, length, and name. *For more information, see [Working with regions](#) on page 80.*

Selected Events

The **Selected Events** category is visually identical to the **Events** category except that the Edit Details window only displays information about events that are selected in your project.

Customizing the Edit Details window

You may arrange and delete columns from each category and save the changes to a personal template. One template is available from which you may create your own display options.

1. From the Show drop-down list, choose the category that you want to customize.
2. Drag a column's header to the new position. The cursor changes to a column icon (📄) as you move the column. If you want to remove the column from the display, drag the icon off the Edit Details window. Release the mouse to drop the column in its new position.
3. The Template drop-down name changes to "Untitled." Enter a new name in the Template drop-down.

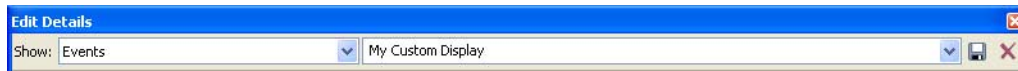

4. Click the Save button (📁) on the Edit Details window to save the custom display.

Tip: You can delete a custom display by selecting it from the template drop-down list and clicking the Delete button (✖).

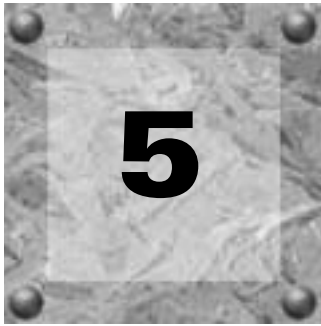

Working with Tracks

Tracks contain the media events on the timeline of a project. There are two types of tracks in a Vegas® project: video and audio. Each type of track has its own features and controls. While tracks can be organized and mixed in any order, track hierarchy can be important in determining the final output for video. Because tracks are containers for events, effects that are applied to a track apply to every event in that track.

Managing tracks

Once you have added a track to your project, you may perform basic editing tasks on it such as duplicating, deleting, and renaming.

Inserting an empty track

Tracks are created for you when you drag events to empty spaces in the timeline. You can also add empty (eventless) tracks to a project. You can record into these tracks or use them as placeholders for specific media that you will add later. For example, you may want to create an empty track and then record a voiceover directly into a project.

1. Right-click in the track view or the track list to display a shortcut menu.
2. Choose **Insert Audio Track** or **Insert Video Track**.

You may also add an empty track from the **Insert** menu by choosing **Audio Track** or **Video Track**. An empty track is added at the bottom of the track list.

Duplicating a track

You can duplicate a track in your project including all of the events contained on it. When you duplicate a track, the duplicate is placed directly below the original track. You can duplicate one track or select multiple tracks to duplicate.

1. Click the track that you want to duplicate. To select multiple tracks, click each one while pressing **[Shift]** to select adjacent tracks or **[Ctrl]** to select nonadjacent tracks.
2. Right-click and choose **Duplicate Track** from the shortcut menu.

Deleting a track

You can delete a track from your project and all of the events contained on it. You can delete one track or select multiple tracks to delete.

1. Select the track that you want to delete. To select multiple tracks, click each one while pressing **[Shift]** to select a range of adjacent tracks or **[Ctrl]** to select discontinuous tracks.
2. From the **Edit** menu, choose **Delete**.

Tip: You can also delete a track by selecting it and pressing **[Delete]**.

Naming or renaming a track

Every track in your project has a scribble strip where you can type a name for the track. The track name may be up to 255 characters long. If the scribble strip is not visible, you may need to increase the height or width of the track by dragging the track's edge to reveal it. *For more information, see [Changing track height](#) on page 108.*

1. Double-click the scribble strip. Any existing name is highlighted on the strip.
2. Type the new track name.
3. Press **[Enter]** to save the track's name.

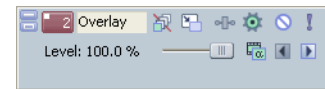

Double-click and type track name

Organizing tracks

Vegas software is flexible in how tracks can be organized. You can arrange and resize tracks to fit your particular needs.

Reordering tracks

When you create tracks, they are arranged in the order that they were added. It is a simple process to reorder tracks to fit your needs. You may reorder one or more tracks at a time.

Note: *Track hierarchy can be critical in video compositing. For more information, see [Compositing](#) on page 212.*

1. In the track list, place the mouse pointer on the track that you want to move.
2. Drag the track to the new position in the track list.

Tip: *When moving a track, you may want to place the mouse pointer on the track number when dragging. This helps avoid accidental modifications to other track list controls.*

Changing track color

When you add a track, it is automatically assigned a color. This color is easily changed. This feature is useful if you want to use color to organize similar tracks.

1. In the track list, right-click a track to display a shortcut menu.
2. From the shortcut menu, choose **Track Display Color**, and choose a color from the submenu.

*To change the available colors, use the **Display Tab** in the **Preferences dialog**.*

Changing track height

You can control track height by dragging the bottom edge of a track in the track list. You can also change track height by clicking the buttons on the track list.

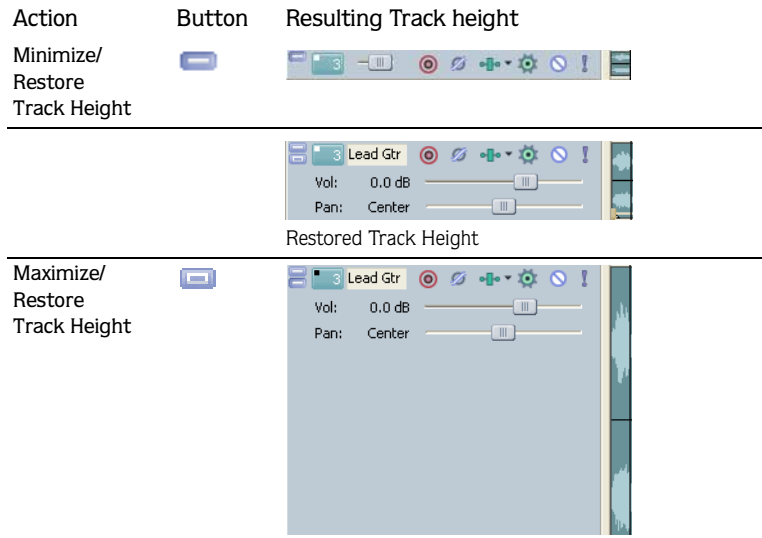

You can also use several different keyboard shortcuts to change all track heights at once:

- Press **Ctrl** + **Shift** + **↓** or **Ctrl** + **Shift** + **↑** to change the height of all tracks in your project at once.
- Press **⌘** to minimize all tracks. Press the key again to restore the tracks to their previous height.
- Press **Ctrl** + **⌘** to make all tracks the default height.

Resizing a track

You can resize a track by dragging its bottom or right border. Place the mouse pointer at the bottom of the track. The cursor turns into an up/down arrow (). Drag up or down and release the mouse to set the desired track size. You can resize the width of the track list in a similar way.

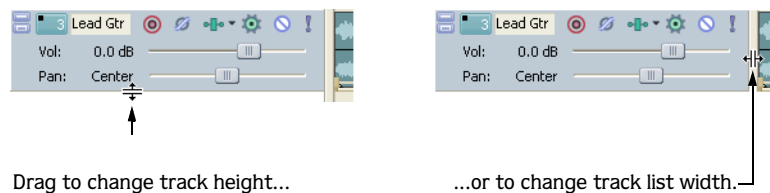

Using the track list

Each track in your project has its own controls, faders, and sliders that are contained in the track list on the left side of the track. You can work with these controls to affect the events on the track.

The controls in the track list can function as trim controls or automation controls for track volume, panning, assignable effects send, and bus send levels. Adjusting the trim control affects the level of the entire track.

When a track does not use envelopes (or when the track automation mode is set to Off), the trim level is added to the track fader. For example, setting the track volume fader to +3 dB and the trim control to -3 dB produces a gain of 0 dB.

When a track uses envelopes, the trim level is added to the envelope so your envelope is preserved, but with a boost or cut applied. For example, setting the trim control to -3 dB has the same effect as decreasing every envelope point by 3 dB.

To adjust trim levels, click the **Automation Settings** button  and verify **Show Automation Controls** is not selected. When **Show Automation Controls** is selected, the volume fader and multipurpose slider adjust automation settings.

Using the volume fader (audio only)

The fader in the track header can function as a trim control that adjusts the overall volume of the track, or it can adjust track volume automation settings. *For more information, see [Volume or pan automation \(audio only\)](#) on page 120.*

The trim level is added to the volume automation settings so your envelope is preserved, but with a boost or cut applied. For example, setting the trim control to -3 dB has the same effect as decreasing every envelope point by 3 dB.

1. Click the **Automation Settings** button  and verify **Show Automation Controls** is not selected.
2. Drag the **Vol** fader to control how loud a track is in the mix. If multiple tracks are selected, all selected tracks are adjusted.

As you drag the fader, the volume level displays to the left of the fader. Double-click the fader to set it to 0.0 dB, or double-click the current volume value to enter a specific number.



Drag to change volume.

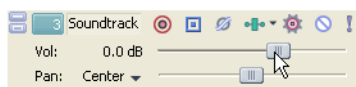

Double-click the fader to set to 0.0 dB.

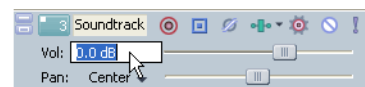

Double-click the current level to enter a value.

Tip: Press **Ctrl** while dragging or use the mouse wheel for finer control of the fader. You can also move the fader by using the right or left arrow keys.

Volume envelopes allow you to automate track volume changes. *For more information, see [Volume or pan automation \(audio only\)](#) on page 120.*

Using the multipurpose slider (audio only)

This slider controls several features, including panning, bus send levels, and assignable effects send levels. The options for the multipurpose slider depend on what your project contains (e.g., busses, assignable effects, etc.). You can select what the slider controls by clicking the slider label. Each item's slider position is independent from the others.

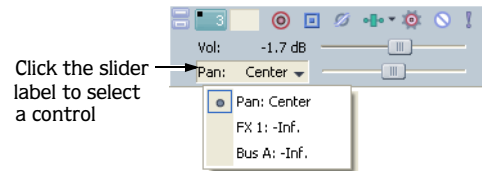

Tip: If you do not see this slider on a track, increase the track height. For more information, see [Resizing a track](#) on page 108.

You can move the slider by pressing **Shift**+the right or left arrow keys.

Adjusting stereo panning

The multipurpose slider in the track header can function as a trim control that adjusts the overall panning of the track, or it can adjust track panning automation settings. For more information, see [Adjusting volume or pan automation settings](#) on page 120.

The trim level is added to the pan automation settings so your envelope is preserved, but with a boost or cut applied. For example, setting the trim control to -9% left has the same effect as moving every envelope point 9% to the left.

1. Click the **Automation Settings** button  and verify **Show Automation Controls** is not selected.
2. Drag the **Pan** slider to control the position of a track in the stereo field. If multiple tracks are selected, all selected tracks are adjusted.

You can further control the panning by right-clicking the multipurpose slider and selecting an option from the shortcut menu:

- The **Add Channels** panning model is most useful for panning stereo source material. This model makes the stereo image appear to move as a unit between the speakers. As the fader is moved from the center to a side, more and more of the signal from the opposite side is folded into the side you are panning towards, until at the extreme, both channels are fed at full intensity into a single channel. This panning model uses a linear panning curve.
- The **Balance** panning model is most useful for adjusting the relative signal levels of the right and left channels in stereo source material. In this model, moving from the center to a side, the opposite side starts at a base dB level (either 0 dB, -3 dB, or -6 dB) and decays to no signal level. The signal in the side you are panning towards starts at the base dB level (either 0 dB, -3 dB, or -6 dB) and increases to 0 dB. This panning model uses a linear panning curve.
- The **Constant Power** panning model is most useful for panning mono source material. As you move the fader from side to side, this model creates the illusion of the source moving around the listener from one side to the other in a semi-circle. This model uses a constant-power panning curve.

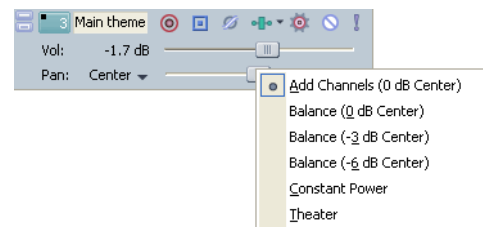

You can add a pan envelope to automate panning changes. For more information, see [Composite level automation \(video only\)](#) on page 124.

Assigning audio tracks to assignable effects chains

 Assignable effects are only available in the full version of Vegas software.

Assignable effects chains are made up of one or more plug-ins that are used to add audio effects to a track's signal. You can adjust the level of a track that is sent to an assignable effects chain using the multipurpose slider in the track list. The multipurpose slider can function as a trim control that adjusts the overall assignable effects send level for the track, or it can adjust assignable effects automation settings. For more information, see [Adjusting assignable effects automation levels](#) on page 121.

1. Click the Automation Settings button  and verify Show Automation Controls is not selected.
2. Click the label on the multipurpose slider to display a drop-down list.
3. Choose the assignable effects chain that the track will use.
4. Drag the slider to adjust the level of the track sent to the assignable effects chain.

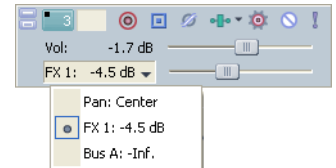

Note: Assignable effect sends are post-volume by default. To change to pre-volume, right-click the multipurpose slider and choose Pre Volume from the shortcut menu.

Assigning audio tracks to busses

If your project contains multiple busses, you can assign a track to a specific bus.

 Multiple audio busses are only available in the full version of Vegas software.

1. Click the Bus button () in the track list to display a drop-down list of available busses. This button appears only if the project contains multiple busses. For more information, see [Adding busses to a project](#) on page 145.
2. From the drop-down list, choose the bus for the track's output.

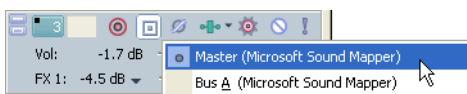

Select a bus for playback

Adjusting bus send levels

When a track is routed to a bus, you can control the level of tracks sent to the bus using the multipurpose slider. The multipurpose slider in the track header can function as a trim control that adjusts the overall send level of the track, or it can adjust bus send automation settings. For more information, see [Adjusting bus automation levels](#) on page 122.

1. Click the Automation Settings button  and verify Show Automation Controls is not selected.
2. Click the label on the multipurpose slider and choose an assignable effects chain from the menu.
3. Drag the FX fader to control the level of the track sent to each of the assignable FX chains that you have created. Dragging the fader to the left cuts the volume; dragging to the right boosts the volume.

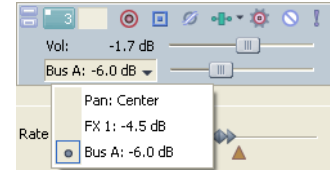

You can hold **Ctrl** while dragging a fader to adjust the setting in finer increments, or double-click the fader to return it to 0 dB.

If multiple tracks are selected, the trim level of all selected tracks is adjusted.

Note: Bus sends are pre-volume by default. To change to post-volume, right-click the multipurpose slider and choose Post Volume from the shortcut menu.

For more information, see [Adjusting a bus send level](#) on page 149 or [Assigning audio tracks to assignable effects chains](#) on page 151.

 **Note:** Multiple busses and assignable effects are only available in the full version of Vegas software.

Adjusting the composite level (video only)

The Level slider in the track header determines the opacity of the video track. The slider can function as a trim control that adjusts the overall opacity of the track, or it can adjust track composite level automation settings. For more information, see [Adjusting the composite level automation settings](#) on page 124.

The trim level is added to the composite level automation settings so your envelope is preserved, but with a boost or cut applied. For example, setting the trim control to -3% has the same effect as decreasing every envelope point by 3%.

1. Click the Automation Settings button  and verify Show Automation Controls is not selected.
2. Drag the slider to control the transparency or blending of each track. Left is 100% transparent and right is 100% opaque. You can also double-click the percent to enter a specific value.

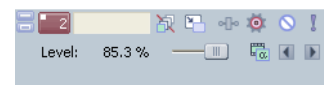

Selecting the compositing mode

Click the Parent Overlay Mode or Compositing Mode button and choose a mode from the menu to determine how the transparency in a video track is generated. Since lower tracks show through higher tracks, it is the compositing mode of the higher track that determines how much of the lower track shows though. The compositing mode of the lowest video track adjusts its transparency against the background.

For more information, see [Compositing](#) on page 212.

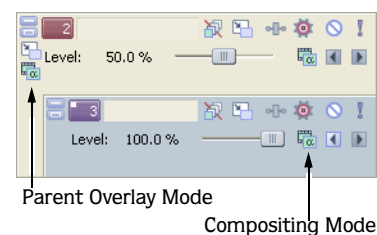

Bypassing motion blur envelopes (video only)

If you applied a motion blur envelope to your video bus track (available only in the full version of Vegas software), this envelope affects all tracks. You can select specific tracks to bypass this envelope by clicking a track's Bypass Motion Blur button (⊞). For more information on motion blur envelopes, see [Adding a motion blur envelope](#) on page 125.

Using track motion (video only)

Use the Track Motion button (⊞) to move a video track over another track (i.e., picture-in-picture). For more information on adding track motion, see [Adding track motion](#) on page 245.

Phase inverting a track (audio only)

The Invert Track Phase button (⊞) inverts the audio track at its baseline, in effect reversing its polarity. Inverting a track, while creating little audible difference, is occasionally useful for matching transitions when mixing audio on separate tracks or fine-tuning a crossfade.

You can also phase invert an audio event. If an event on a track is inverted and you invert the track, the event is doubly-inverted (restored to its original state). For more information, see [Invert phase \(audio only\)](#) on page 134.

Muting a track

The Mute button (⊞) in the track list temporarily suspends playback of the track so that you can focus on another track. When a track is muted, it appears grayed out on the track view. You can mute more than one track at a time. The Mute button can mute a track or change its mute automation state. For more information, see [Mute automation \(audio and video\)](#) on page 119.

To mute a track, click the **Automation Settings** button (⚙) and verify **Show Automation Controls** is not selected. Next, click the Mute button.

To mute several tracks, select the tracks and click the Mute button on any of the selected tracks. Click the Mute button again to restore the track(s).

Tip: Press **Ctrl** and click the Mute button to mute only the selected track (and restore any other muted tracks). If the selected track is already muted, press **Ctrl** and click the Mute button to restore all tracks.

When you have multiple levels of parent and child tracks, clicking the Mute button on a parent track mutes the parent track and its compositing children.

In the sample track list, muting track 1 will mute tracks 1 through 6. Muting track 4 will mute tracks 4 through 6.

Muting all audio or video tracks

You may mute either all audio or all video tracks in a project. From the **Options** menu, choose **Mute All Audio** or **Mute All Video**.

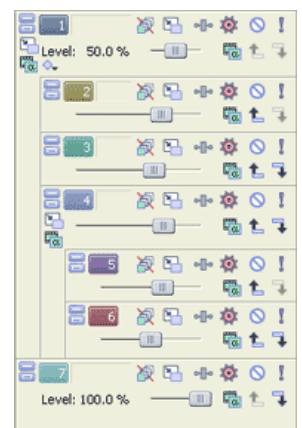

Soloing a track

The Solo button (⏏) in the track list isolates a track's events for playback. This allows you to focus on a track's contents without the distraction of other tracks. You can solo more than one track at a time.

To solo a track, click the Solo button on that track. To solo several tracks, select the tracks and click the Solo button on any of the selected tracks. Click the Solo button again to restore the track(s) for playback.

Tip: Press **Ctrl** and click the Solo button to solo only the selected track (and restore any other soloed tracks). If the selected track is already soloed, press **Ctrl** and click the Solo button to restore all tracks.

When you have multiple levels of parent and child tracks, clicking the Solo button on a parent track solos the parent track and its compositing children. Other nonsoloed tracks at the same compositing level are bypassed.

In the sample track list, soloing track 1 will solo tracks 1 through 6.

Soloing track 4 will solo tracks 4 through 6. Tracks 2 and 3 are bypassed, and tracks 1 and 7 play normally.

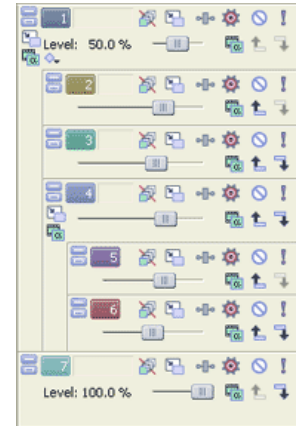

Setting default track properties

You can use the settings of a selected track to determine the default settings for all new tracks in your project. Properties that can be set appear in the Set Default Track Properties dialog.

1. Set up a track in your project with the properties to use as default settings for new tracks.
2. Right-click the track number and choose **Set Default Track Properties**. The Set Default Track Properties dialog appears.
3. Select the check boxes that you want to set as defaults.
4. Click OK.

Any new tracks created in the project will have these defaults. To return to the original settings for new tracks, select the Restore original defaults check box in the Set Default Track Properties dialog.

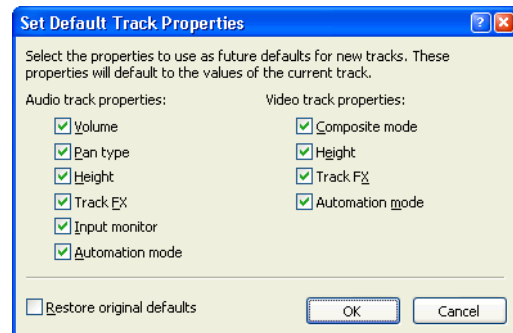

Track automation envelopes

Track automation envelopes allow you to control volume, audio panning, opacity, and fade to color effects of a particular track over time. *For more information, see [Working with track envelopes](#) on page 126.*

Using audio bus tracks

 *Audio bus tracks are only available in the full version of Vegas software.*

From the **View** menu, choose **Audio Bus Tracks** to toggle the display of audio bus tracks at the bottom of the track view. An audio bus track exists for each bus or assignable effects chain in your project and serves as a timeline representation of each bus or assignable effects chain.

You can use bus tracks to automate volume, panning, and effect parameters using envelopes. *For more information, see [Bus automation \(audio only\)](#) on page 122.*

Adding envelopes to an audio bus track

Adding volume, panning, and effect automation envelopes to a bus track is just like adding an envelope to a standard track. *For more information, see [Composite level automation \(video only\)](#) on page 124.*

Adding effects to audio bus tracks

Click the Bus FX button (+) in the bus track header to add or edit bus effects. If there are no effects on the bus, clicking this button displays the Plug-In Chooser. If an audio bus already has effects assigned, clicking this button displays the Audio Plug-In window.

Clicking this button has the same effect as clicking the button on a bus control in the Mixer window or the Video Preview window.

If the bus effects chain includes plug-ins with automatable parameters, the Bus FX button is displayed as a



Muting or soloing an audio bus track

Click the Mute (M) or Solo (S) button in the bus track header to mute or solo a bus.

Clicking these buttons on a bus track has the same effect as clicking the buttons on a bus control in the Mixer window.

Resizing audio bus tracks

You can drag the horizontal splitter between the track list and bus tracks to increase or decrease the space allocated to bus tracks. Perform any of the following actions to resize individual bus tracks:

- Drag a bus track's bottom border to set its height.
- Click Minimize (M) to minimize a track vertically.
- Click Maximize (X) to zoom in vertically so a bus track fills the lower portion of the timeline.
- After minimizing or maximizing a bus track, click either button again to return a bus track to its previous height.
- Press **Ctrl**+**Shift**+**↑**/**↓** when the bus track area has focus to resize all bus tracks at once.

Using video bus tracks

 *Video bus tracks are only available in the full version of Vegas software.*

From the **View** menu, choose **Video Bus Track** to toggle the display of the video bus track at the bottom of the track view. A single bus track exists as a timeline representation of the main video output.

You can use bus tracks to animate video output effects using keyframes, add motion blur envelopes, or video supersampling envelopes.

Adding keyframes to the video bus track

Adding keyframes to the video bus track is just like working with any other video track. Use video bus track keyframes to animate video output effects. *For information on adding keyframes, see [Using keyframe animation](#) on page 237.*

Adding envelopes to the video bus track

You can add fade-to-color, motion blur amount, and video supersampling envelopes to the video bus track to affect your video output. *For more information, see [Working with track envelopes](#) on page 126.*

Adding effects to video bus tracks

Click the Video Output FX button (+) in the bus track header to add or edit video output effects. If there are no video output effects, clicking this button displays the Plug-In Chooser. If you've already set up video output effects, clicking the button displays the Video Output FX window.

Muting the video output

Click the Mute button (S) in the bus track header to mute all video output.

Bypassing video effects and envelopes

Click the Bypass FX and Envelopes button (B) in the bus track header to bypass all video output effects and bus track envelopes.

Resizing video bus tracks

You can drag the horizontal splitter between the track list and bus tracks to increase or decrease the space allocated to bus tracks. Perform any of the following actions to resize individual bus tracks:

- Drag a bus track's bottom border to set its height.
- Click Minimize (M) to minimize a track vertically.
- Click Maximize (M) to zoom in vertically so a bus track fills the lower portion of the timeline.
- After minimizing or maximizing a bus track, click either the Minimize or Maximize button again to restore a bus track to its previous height.
- Press **Ctrl**+**Shift**+**↑**/**↓** when the bus track area has focus to resize all bus tracks at once.

Rendering to a new track

 *Rendering to a new track is only available in the full version of Vegas software.*

Rendering or mixing multiple tracks to a single track can be a good method of decreasing the complexity of a project and speeding up future renders. The original tracks and their events are unaffected when you render (mix) to a single track.

Typically, you would use this feature when you are finished refining a few tracks and want to combine them. When you render multiple tracks, any envelope or track effects that you have applied are rendered into the new track. The original source files remain unaffected and the new track(s) are saved to a new file.

When working with DV files, select a DV template to avoid any loss of quality. *For more information, see [Working in DV format](#) on page 198.*

Note: *Every video render that uses compression results in a loss of quality from the original source material. To minimize loss of quality, minimize the number of video renders that use compression.*

1. Click the Solo button (I) for the tracks that you want to mix down. If no tracks are soloed, the rendered track will match the Master Bus output. Create a time selection if you want to mix down a portion of your project.

Video tracks will be rendered into a single video track, and audio tracks will be rendered into a single stereo audio track.

2. From the **Tools** menu, choose **Render to New Track** or press **Ctrl**+**M**. The Render to New Track dialog appears.

3. Complete the dialog as follows:

- From the Save in drop-down list, select the drive or folder to save the new media file.
- Type a file name in the File name box.
- From the Save as type drop-down list, choose the file format (e.g., .wav for audio or .avi for video).
- From the Template drop-down list, choose a format from the template list. Alternately, click Custom to set custom rendering settings. *For more information, see [Customizing the rendering process](#) on page 275.*
- Select Render loop region only if you only want to render the time selection area.
- Select Stretch video to fill output frame size (do not letterbox) to adjust the aspect ratio so the output frame is filled on all edges. When the check box is cleared, the current aspect ratio is maintained and black borders are added to fill the extra frame area (letterboxing).

4. Click Save to render to a new track.

As the tracks are being rendered (mixed down), a small dialog appears displaying the progress of the render. A status bar also appears in the lower-left portion.



Tip: *You can cancel the rendering process by clicking the Cancel button on the status bar.*

After the new track is rendered, it appears at the top of the track view. If you render the entire project, you may delete (or mute) the other tracks from the project, since they are all contained on the new track.

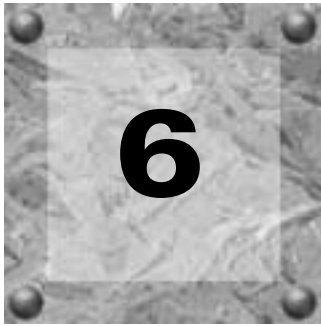

Using Automation

Automation allows you to control audio and video levels, panning, and effect parameter automation over time. You can create fades, apply stereo panning, and vary effect parameters throughout your project. Automation is represented on the Vegas® timeline as an envelope or set of keyframes. You can create automation by adding envelopes or keyframes to your tracks (including bus tracks), or you can record automation parameters by adjusting controls in the Vegas interface (or on a control surface) during playback.

Showing or hiding automation controls

The controls in the track list can function as trim controls or automation controls for track volume, panning, assignable effects send, and bus send levels. Adjusting the trim control affects the level of the entire track.

To display trim controls in the track header, click the **Automation Settings** button  and select **Show Automation Controls**.

Track automation

Track automation will always affect all events on the track. This means that any event envelopes will be calculated after the track automation. For more information, see [Using audio event envelopes \(ASR\)](#) on page 137.

Tip: Choose a fade type from the **Audio default** drop-down list on the **Editing** tab of the **Preferences** dialog to set the default fade type that will be used when you add volume and panning envelopes. This setting is used only when you create new envelopes—when you add a point to an existing envelope, the new point always uses the same fade type as the preceding envelope point. Also, this setting is not used for event envelopes.

Mute automation (audio and video)

Mute automation changes a track's mute state throughout your project. Mute automation is either on or off with no fade between. If you want to use fades, apply volume automation.



When you apply mute automation to a track, it's possible to have a track that is muted and soloed simultaneously. The mute state overrides the solo state:

- If a track's **Solo** button is selected, the track is included in the solo group, but it will be muted whenever the mute automation is set to mute the track.
- If the track's **Mute** button is selected, the track is muted regardless of the mute automation settings.

Adding or removing mute automation

1. Select a track.
2. From the **Insert** menu, choose **Audio Envelopes** or **Video Envelopes**, or right-click in the track list and choose **Insert/Remove Envelope** from the shortcut menu.
3. From the submenu, choose **Mute**. A check mark is displayed next to the command, and an envelope is added to the timeline.
4. You can adjust the automation by editing the envelope in the timeline or by using the **Mute** button  in the track header when **Show Automation Controls** is selected.

Adjusting mute automation settings

1. Click the **Automation Settings** button  and select **Show Automation Controls**. The **Mute** button is displayed as .
2. Click the **Mute** button to change the track's mute automation state.

The button behaves differently depending on the track automation recording mode:

- When the track automation mode is set to **Off**, the button mutes the entire track.
- When the track has a mute envelope and the track automation mode is set to **Read**, the button changes state to reflect the envelope setting during playback but cannot be adjusted.
- When the track has a mute envelope and the track automation mode is set to **Touch** or **Latch**, the button edits the envelope setting at the cursor position.

If you click the **Mute** button  during playback, the behavior varies depending on the selected automation recording mode. For more information, see [Automating 5.1 surround projects](#) on page 130.

Volume or pan automation (audio only)

You can change a track's volume or position in the stereo field throughout a project using automation envelopes.

Adding or removing volume or pan automation

1. Select an audio track.
2. From the **Insert** menu, choose **Audio Envelopes**, or right-click in the track list and choose **Insert/Remove Envelope** from the shortcut menu.
3. From the submenu, choose **Volume** or **Pan**. A check mark is displayed for the automation types that are used on the selected track.

Panning envelopes will use the current panning mode for the Pan slider in the track list. For more information, see [Adjusting stereo panning](#) on page 110.

Adjusting volume or pan automation settings

1. Click the **Automation Settings** button and select **Show Automation Controls**. The fader/slider handle is displayed as a  in automation mode.
2. Drag the **Vol** fader to control how loud a track is in the mix or drag the **Pan** slider to control the position of the track in the stereo field.

The fader and the slider behave differently depending on the track automation recording mode:

- When the track automation mode is set to **Off**, the fader adjusts the volume of the entire track and the slider pans the entire track. In this mode, the automation control acts as a second trim control.

- When the track has a volume envelope and the track automation mode is set to **Read**, the fader/slider will follow the envelope during playback but cannot be adjusted.
- When the track automation mode is set to **Touch** or **Latch**, the fader/slider edits the envelope setting at the cursor position. If the track does not have a volume/pan envelope, an envelope will be added when you adjust the fader/slider.

If multiple tracks are selected, all selected tracks are adjusted.

If you adjust the fader/slider during playback, the behavior varies depending on the selected automation recording mode. For more information, see [Automating 5.1 surround projects](#) on page 130.

Assignable effects automation (audio only)



You can use assignable effects automation to vary the level of a track sent to an assignable effects chain.

Adding or removing assignable effects automation

Before you can add an assignable effects envelope, you'll need to add an assignable effects chain to your project. For more information, see [Creating an assignable effects plug-in chain](#) on page 154.

1. Select an audio track.
2. From the **Insert** menu, choose **Audio Envelopes**, or right-click in the track list and choose **Insert/Remove Envelope** from the shortcut menu.
3. From the submenu, choose the effects chain where you want to send the selected track. A check mark is displayed for each assignable effects chain that is automated for the selected track.

Adjusting assignable effects automation levels

1. Click the **Automation Settings** button  and select **Show Automation Controls**. The fader handle is displayed as a  in automation mode.
2. Click the label on the multipurpose slider and choose an assignable effects chain from the menu.

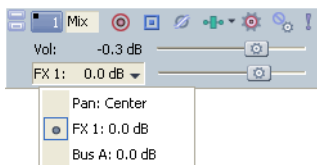

3. Drag the FX fader to control the level of the track sent to each of the assignable FX chains that you have created.

The fader behaves differently depending on the track automation recording mode:

- When the track has an assignable effects envelope and the track automation mode is set to **Off**, the fader adjusts the send level of the entire track. In this mode, the automation control acts as a second trim control.
- When the track has an assignable effects envelope and the track automation mode is set to **Read**, the fader will follow the envelope during playback but cannot be adjusted.
- When the track has an assignable effects envelope and the track automation mode is set to **Touch** or **Latch**, the fader edits the envelope setting at the cursor position. If the track does not have an envelope, one will be created when you adjust the fader.

If multiple tracks are selected, all selected tracks are adjusted.

If you adjust the fader during playback, the behavior varies depending on the selected automation recording mode. For more information, see [Automating 5.1 surround projects](#) on page 130.

Bus automation (audio only)



You can use bus automation envelopes to vary the level of a track sent to a bus.

Adding or removing a bus automation envelope

Before you can add a bus envelope, you'll need to specify the number of busses for your project.

1. Select an audio track.
2. From the **Insert** menu, choose **Audio Envelopes**, or right-click in the track list and choose **Insert/Remove Envelope** from the shortcut menu.
3. From the submenu, choose the bus where you want to send the selected track. A check mark is displayed for each bus send level that is automated for the selected track.

Adjusting bus automation levels

1. Click the **Automation Settings** button  and select **Show Automation Controls**. The fader handle is displayed as a  in automation mode.
2. Click the label on the multipurpose slider and choose a bus from the menu.

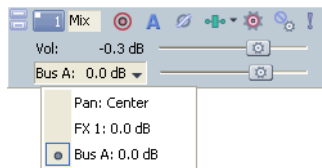

3. Drag the fader to control the level of the track sent to each of the assignable FX chains that you have created. Dragging the fader to the left cuts the volume; dragging to the right boosts the volume.

The fader behaves differently depending on the track automation recording mode:

- When the track automation mode is set to **Off**, the fader adjusts the send level of the entire track. In this mode, the automation control acts as a second trim control.
- When the track has a bus envelope and the track automation mode is set to **Read**, the fader will follow the envelope during playback but cannot be adjusted.
- When the track has a bus envelope and the track automation mode is set to **Touch** or **Latch**, the fader edits the envelope setting at the cursor position. If the track does not have an envelope, one will be created when you adjust the fader.

If multiple tracks are selected, all selected tracks are adjusted.



If you adjust the fader during playback, the behavior varies depending on the selected automation recording mode. For more information, see [Automating 5.1 surround projects](#) on page 130.

Adding or removing track effect automation



If a plug-in supports automation, you can dynamically adjust effect parameters over time.

 This feature is only available in the full version of Vegas software.

Adding or removing effect automation envelopes

If a plug-in supports automation, you can use envelopes to adjust effect parameters over time. The appearance of the plug-in in the Plug-In Chooser window indicates whether the plug-in supports automation. Plug-ins with this icon () support automation, while plug-ins with this icon () do not. In addition, you can quickly locate plug-ins that support automation in the Automatable subfolder.

 Effect automation envelopes are only available in the full version of Vegas software.

1. Click the Track FX button () on a track to open the Audio Plug-In window.
If no track effects exist, clicking the Track FX button displays the Plug-In Chooser. Use the Plug-In Chooser to create an effect chain including an automatable plug-in.
2. Click the Configure FX Automation button () to display the FX Automation Chooser.
3. Click a plug-in at the top of the FX Automation Chooser. A list of the effect's automatable parameters appears.
4. Select the check box for each parameter that you want to control with an envelope. You can use the Select All and Select None buttons to quickly change your selections to all or none of the parameters.

Note: *If you're working with a 5.1 surround project, you can select the **Enable** check boxes to determine which channels will be affected by the plug-in. An automation envelope is added to the timeline for each selected channel so you can enable or bypass the plug-in during the project. If you want to use distinct plug-in settings for each channel (separate EQ settings for the front and surround speakers, for example), you can add multiple instances of the plug-in to the track effects chain and select the **Enable** check boxes for the channels you want each instance of the plug-in to affect.*

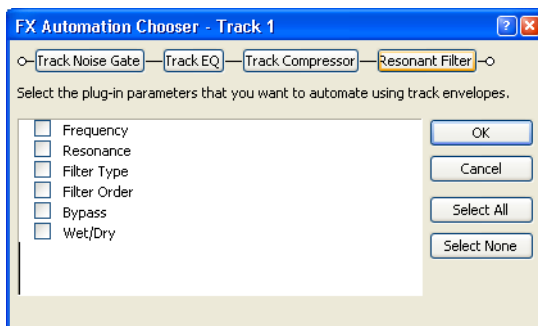

5. Click OK to close the FX Automation Chooser.

Envelopes are displayed on the track for parameters that you selected in the FX Automation Chooser. To control which effect parameter envelopes are displayed on the track, click the arrow adjacent to the Track FX button () and choose an envelope from the menu.

Press **[E]** to toggle through the display of all effect parameter automation envelopes.

Adjusting effect automation settings

You can adjust automated effect parameters by editing the envelopes in the timeline or by recording automation with the controls in the Audio Plug-In Window.

If you've enabled the **Bypass** parameter for a plug-in, you can click the **Bypass** button in the plug-in's banner to toggle the Bypass envelope at the cursor position.



Note: When you automate an effect's frequency parameter, such as the frequency parameters in the track EQ effect, you may notice that the frequency changes are more apparent when moving through the lower frequencies. This is because frequency scales in track EQ and other plug-ins use a logarithmic scale, but effect automation uses linear interpolation. To make the automated frequency changes sound more natural, change the fade curve types to change the interpolation rates between envelope points. For high-to-low frequency sweeps, use a fast fade curve; for low-to-high frequency sweeps, use a slow curve. For more information, see [Changing envelope fade curves](#) on page 127.



Composite level automation (video only)

You can use the composite level automation envelopes to adjust the opacity of a track over time.

Adding or removing composite level automation

1. Select a video track.
2. From the **Insert** menu, choose **Video Envelopes**, or right-click in the track list and choose **Insert/Remove Envelope** from the shortcut menu.
3. Choose **Track Composite Level** from the submenu or shortcut menu.
4. You can adjust the envelope by editing the envelope in the timeline or by adjusting the slider in the track header when **Show Automation Controls** is selected.

Adjusting the composite level automation settings

1. Click the **Automation Settings** button  and select **Show Automation Controls**. The slider handle is displayed as a  in automation mode.
2. Drag the slider to control the transparency or blending of each track. Left is 100% transparent and right is 100% opaque. You can also double-click the percent to enter a specific value.
 - When the track automation mode is set to **Off**, the slider adjusts the send level of the entire track. In this mode, the automation control acts as a second trim control.
 - When the track has a composite level envelope and the track automation mode is set to **Read**, the slider will follow the envelope during playback but cannot be adjusted.
 - When the track has a composite level envelope and the track automation mode is set to **Touch** or **Latch**, the slider edits the envelope setting at the cursor position. If the track does not have an envelope, one will be created when you adjust the slider.

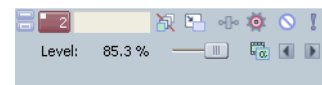

If multiple tracks are selected, all selected tracks are adjusted. If you adjust the slider during playback, the behavior varies depending on the selected automation recording mode. For more information, see [Automating 5.1 surround projects](#) on page 130.

Adding a motion blur envelope

Motion blur can help you make computer-generated animation look more realistic. For example, if you use track motion or event pan/crop to move a clip across the frame, each frame is displayed clearly when no motion blur is applied. Turning on motion blur adds a motion-dependent blur to each frame to create the appearance of smooth motion in the same way a fast-moving subject is blurred when you take a photograph with a slow shutter speed.

Note: *Motion blur significantly increases your rendering time. Adjust the envelope to apply motion blur only where necessary.*

1. Right-click the video bus track, choose **Insert/Remove Envelope** from the shortcut menu, and then choose **Motion Blur Amount** from the submenu.
2. Add and adjust envelope points as necessary to set the time interval that will be used for blurring. Increasing the value emphasizes the blur effect. For example, setting the envelope to 0 means no blurring will occur; setting the envelope to 1 second means that each frame will be blurred for one-half second before and after the frame.
3. The motion blur envelope affects all tracks. To bypass motion blur for a track, select the **Bypass Motion Blur** button () in the track header.
4. To change blur type, choose a setting from the **Motion blur type** drop-down list on the **Video** tab in the **Project Properties** dialog. This setting determines the shape of the blur and the opacity of the frames.

Adding a video supersampling envelope

Video supersampling can improve the appearance of computer-generated animation by calculating intermediate frames between the project's frame rate, allowing you to create smoother motion blurring or motion from sources such as track motion, event pan/crop, transitions, or keyframable effects.

Note: *The effect of video supersampling is less apparent with video that contains fast motion, and supersampling cannot improve the appearance of existing video.*

1. Right-click the video bus track, choose **Insert/Remove Envelope** from the shortcut menu, and then choose **Motion Blur Subsampling** from the submenu.
2. Add and adjust envelope points as necessary to indicate how many frames will be calculated between frames (using the project's frame rate) to create the blur.

Note: *Video supersampling significantly increases your rendering time. For example, when you set the video supersampling envelope to 2, Vegas software renders twice as many frames as it would without supersampling. Adjust the envelope to apply supersampling only where necessary.*

Working with track envelopes

Envelopes represent volume, audio panning, opacity, and fade to color automation settings in the timeline.

Track Type	Envelope type	Description	Color
Audio	Volume	Controls track volume.	Blue
Audio	Bus send volume	Controls track level sent to bus.	Lilac
Audio	Assignable effects send volume	Controls track level sent to assignable effects control.	Green
Audio	Pan	Controls the position of a track in the stereo field (pan).	Red
Video	Composite level	Controls track opacity/transparency.	Blue
Video	Fade to color	Controls fading of a track to color. Designate a top and bottom color by right-clicking the track, choosing Fade Colors from the shortcut menu, and choosing Top or Bottom from the submenu.	Red
Video bus	Motion blur	Adds a motion-dependent blur to each frame to smooth computer-generated animation.	Lilac
Video bus	Video supersampling	Calculates intermediate frames between the project frame rate to create smooth motion blurring.	Rust

 *Composite Level envelopes and Fade to Color envelopes are only available in the full version of Vegas software.*

Adding envelope points

Once you add an envelope to a track, you may add points to it. These points are used to edit the envelope line in order to automate the control.

1. Place the mouse pointer on the envelope's line. The pointer changes to a hand icon () .
2. Right-click and choose **Add Point** from the shortcut menu or double-click to add an envelope point. A square point appears on the envelope line.

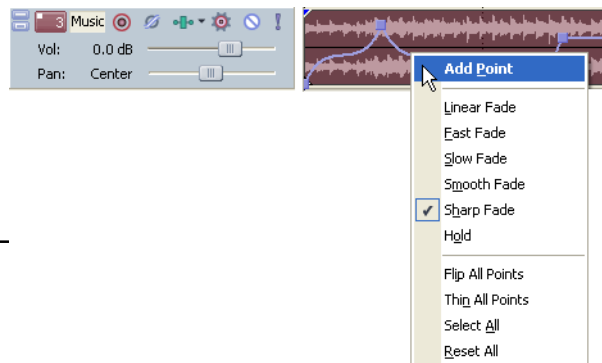

Tip: You can use ripple editing to automatically move envelope points as you edit in the timeline. For more information, see [Applying post-edit ripples](#) on page 73.

Thinning envelope points

Thinning envelope points decreases the number of points on an envelope while retaining the envelope's overall settings. Right-click an envelope and choose **Thin All Points** from the shortcut menu to thin the entire envelope.

To apply thinning to a section of the envelope, create a time selection, right-click the envelope, and then choose **Thin Selected Points** from the shortcut menu.

Note: Thinning is intended to reduce the number of envelope points created through automation recording and will have little or no effect if you create envelopes by adding and editing points manually.

Deleting envelope points

You can delete a point by right-clicking it and choosing **Delete** from the shortcut menu. If you want to delete all envelope points, right-click a point and choose **Reset All** from the shortcut menu.

Moving envelope points

Once you have added envelope points, you can raise and lower them to different levels along the timeline, or you can adjust the envelope's location along the timeline by dragging it right or left. You can move one point at a time, even during playback and check the results in real time. If snapping is enabled, the envelope point snaps to time divisions as you drag. Hold **[Shift]** while dragging to override snapping.

Tip: You can move multiple envelope points at once using the *Envelope Edit tool*. For more information, see [Using the Envelope Edit tool](#) on page 128.

1. Place the mouse pointer on an envelope point. The pointer changes to a hand icon ()
2. Drag the point to the desired position. As you move an envelope point, a ToolTip displays both the point's location on the timeline and its decibel level/percent pan.



3. Click the Play () or Play From Start () button to play the project and check the timing of the envelope.

Tip: You can also set the value of the point by right-clicking an envelope point and choosing a setting from the shortcut menu.

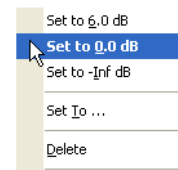

Changing envelope fade curves

You can set the type of fade curve used after each envelope point: linear, fast, slow, smooth, or sharp. You can select either a point or a portion of the envelope to set the fade curve. If you select a portion of the envelope, the fade curve is applied to that envelope segment. If you select a point, the fade curve is applied to the segment of the envelope after the selected point.

1. Right-click a point or a portion of the envelope to display a shortcut menu.
2. From the shortcut menu, choose the curve type.

Tip: If you use the same fade curve frequently, you can set it as a default all new audio or video envelopes. For more information, see [Editing tab](#) on page 299.

Hiding track envelopes

After you have set your envelopes on the tracks, you can hide them from the track view. Hiding track envelopes does not affect playback. The points that you set still automate the controls, even though the envelopes are not visible.

1. From the **View** menu, choose either **Audio Envelopes** or **Video Envelopes**. A submenu appears. Envelopes that are currently displayed are selected in the submenu.
2. From the submenu, choose an envelope name. All envelopes in your project of that type no longer appear in the track view.

Tip: From the **View** menu, choose **Show Envelopes** (or press **Ctrl+Shift+E**) to toggle the display of all envelopes in the timeline.

If you've added effect automation envelopes to a track, the track can get cluttered. Click the down arrow next to the **Track FX** button  and choose an envelope from the drop-down list to select which envelope you want to display.

Removing track envelopes

When an envelope is removed, the events on the track no longer have automated control and the envelope line no longer displays.

1. Select the track(s) from which you want to remove envelopes.
2. From the **Insert** menu, choose either **Audio Envelopes** or **Video Envelopes**. A submenu appears. Envelopes that are currently displayed are selected.
3. From the submenu, click an envelope name. The envelope of that type is removed from the selected track.

Alternatively, right-click an empty area of a track, choose **Insert/Remove Envelope** from the shortcut menu, and choose an envelope type from the submenu to remove that envelope.

Note: When you remove a track envelope from a track and then add it again, all points are reset.

Using the Envelope Edit tool

You can also edit envelope points using the Envelope Edit tool. To use this tool, click the Envelope Edit Tool button . The advantage of switching to this tool to edit envelopes is that events cannot be moved when this tool is selected, thereby protecting them from changes. This effectively locks all of the events and effects in a project while you modify envelopes.

Selecting and adjusting envelope points

1. Select the Envelope Edit Tool button .
2. Click within a track to select it.
3. Drag along the timeline to select envelope points.
4. Drag the selected envelope points to a new position.

To deselect envelope points, click anywhere in the event that is not part of the envelope.

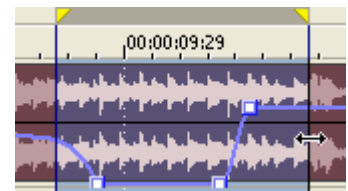

Drag to select envelope points.

Cutting, copying, and pasting envelope points

1. Select the Envelope Edit Tool button (🔗).
2. Click within a track to select it.
3. Drag along the timeline to select envelope points.
4. From the **Edit** menu, choose **Cut** or **Copy**.
5. Click to position the cursor where you want to paste envelope points. Click within a different track if you want to paste envelope points to another track.
6. From the **Edit** menu, choose **Paste**. The envelope points are pasted in the new position.

Copying an envelope to another track

1. Select the Envelope Edit Tool button (🔗). The Envelope Edit tool is active.
2. Click within a track to select it.
3. From the **Edit** menu, choose **Select All**.
4. From the **Edit** menu, choose **Copy**.
5. Click within a track to select it.
6. Click **Go to Start** (⏮) if you want the envelope to appear exactly as it was in the original track, or click to position the cursor where you want the envelope to start.
7. From the **Edit** menu, choose **Paste**. The envelope is pasted on the track.

The original
envelope...

...and the newly
pasted copy.

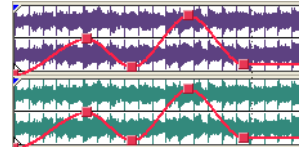

Locking envelopes to events

Track envelopes extend for the length of a track and are independent of the events on the track. This means that the envelope remains in place when you move the events in the track. However, track envelopes can be set to move with the underlying events, thus preserving the timing of envelope points in relation to events.

To lock all of the envelopes in a project to the events in which they occur, click the **Lock Envelopes to Events** button (🔗) or, from the **Options** menu, choose **Lock Envelopes to Events**. You can turn this feature off by clicking the button again.

The original event

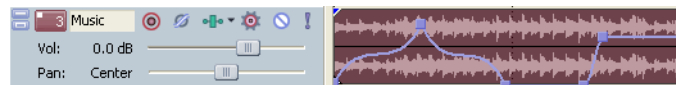

Moving the event with
Lock Envelopes to Events
turned on



Moving the event with
Lock Envelopes to Events
turned off



Automating 5.1 surround projects

In a 5.1 surround project, you can automate the center channel's volume and surround panning using keyframes. For more information, see [Working with 5.1 Surround](#) on page 173.

Automation recording modes

Automation recording allows you to edit envelope and keyframe settings by using the controls in the Vegas interface. When combined with a control surface, you can create fades and adjust control parameters with a level of control that only a tangible control can provide.

Automation recording is available for the following settings:

- Audio track envelopes (using the controls in the track header).
- Audio track effect parameters for automatable effects (using the controls in Audio Plug-In window).
- Surround panning keyframes.
- Video track envelopes (using the controls in the track header).
- Video track effect parameters (using the controls in Video Track FX window).
- Parent track overlay mode plug-in settings (using the controls in Parent Track Overlay window).
- Track-level mask generator plug-in settings (using the controls in Video Mask FX window).



Note: If you want to thin envelope points after recording automation, you can select the **Smooth and thin automation data after recording** check box on the **External Control & Automation** tab of the **Preferences** dialog or right-click the envelope and choose **Thin Points** from the shortcut menu.

Recording automation settings

1. Add an envelope or automatable/keyframeable effect to a track.

For automatable audio track effects, you must add an effect automation envelope for each parameter you want to automate.

2. Click the **Automation Settings** button  in the track header and select **Show Automation Controls**.
3. Click the **Automation Settings** button and choose **Automation Write (Touch)** or **Automation Write (Latch)** from the menu.

Automation Recording Mode	Track Icon	Description
Automation Write (Touch)		Envelope points or keyframes are created only while a control is being adjusted. When you stop adjusting the control, automation recording stops and the existing envelope points/keyframes are unaffected.
Automation Write (Latch)		Envelope points or keyframes are created when you change a control setting, and recording continues until you stop playback. When you stop adjusting the control, the control's current setting overwrites the existing envelope points/keyframes.





4. Click to position the cursor in the timeline, and click the **Play** button  to start playback.

5. Adjust the control that corresponds to the envelope point or keyframe you want to adjust.
During playback, adjusting a control will create envelope points or keyframes at the cursor position. As long as you're adjusting the control, new envelope points/keyframes will be created for each change of the play cursor's position.
6. Click **Stop**  to end playback and stop recording automation.

Editing sections of your recorded settings in Touch mode

In Touch recording mode, envelope points or keyframes are created only while a control is being adjusted. When you stop adjusting the control, automation recording stops and the existing envelope points/keyframes are unaffected.





Use Touch mode for touching up sections of your recorded automation settings.

1. Click the **Automation Settings** button  in the track header and select **Show Automation Controls**.
2. Click the **Automation Settings** button  and choose **Automation Write (Touch)** from the menu. The icon in the track header is displayed as a .
3. Click to position the cursor in the timeline, and click the **Play** button  to start playback.
4. When you're ready to start editing, adjust the control that corresponds to the envelope point or keyframe you want to adjust. Envelope points/keyframes are updated at the cursor position, and when you stop adjusting the control, the original settings are preserved.
5. Click **Stop**  to end playback and stop recording automation.

Overwriting recorded settings in Latch mode





In Latch mode, envelope points or keyframes are created when you change a control setting, and recording continues until you stop playback. When you stop adjusting the control, the control's current setting overwrites the existing envelope points/keyframes.

Use Latch mode to overwrite automation settings with new values.

1. Click the **Automation Settings** button  in the track header and select **Show Automation Controls**.
2. Click the **Automation Settings** button  and choose **Automation Write (Latch)** from the menu. The icon in the track header is displayed as a .
3. Click to position the cursor in the timeline, and click the **Play** button  to start playback.
4. When you're ready to start editing, adjust the control that corresponds to the envelope point or keyframe you want to adjust.
Envelope points/keyframes are updated at the cursor position until you stop playback.
5. Click **Stop**  to end playback and stop recording automation.



Editing individual envelope points or keyframes





Editing individual envelope points or keyframes gives you fine control over your recorded settings.

1. Click the Automation Settings button  on the track you want to edit and select **Show Automation Controls**.
2. Click the Automation Settings button  and choose **Automation Write (Touch)** or **Automation Write (Latch)** from the menu.
3. Select the parameter you want to edit:
 - For a track envelope, select the envelope tool  and click the envelope point you want to edit. You can right-click a point and choose **Properties** from the shortcut menu to display an effect's property page.
 - For a keyframe, click the **Expand/Collapse Track Keyframes** button  to expand track keyframe rows, and then double-click a keyframe to open its property page. *For more information, see [Using video effects on page 205](#).*
4. Adjust the control that corresponds to the envelope point or keyframe you want to adjust. The selected envelope point/keyframe is edited, and all others are unaffected.

For track envelopes, you can also edit the envelope directly in the timeline.

Setting the automation recording mode for a track

1. Click the Automation Settings button  in the track header and select **Show Automation Controls**.
2. Click the Automation Settings button  and choose a command from the menu to choose the automation mode.

Mode	Track Icon	Description
Off		Automated parameters are ignored during playback. When you switch to Off mode, the control setting from the cursor position is used as a static setting, and the envelope/keyframe is dimmed to indicate that it is unavailable.
Read		The envelope/keyframe value is applied during playback, and the control reflects the envelope/keyframe settings at the cursor position. Adjustments to the control are not recorded.
Automation Write (Touch)		The envelope/keyframe value is applied during playback, and the control follows the envelope/keyframe settings during playback and when you position the cursor. Envelope points or keyframes are created only while a control is being adjusted. When you stop adjusting the control, automation recording stops and the existing envelope points/keyframes are unaffected.
Automation Write (Latch)		The envelope/keyframe value is applied during playback, and the control follows the envelope/keyframe settings during playback and when you position the cursor. Envelope points or keyframes are created when you change a control setting, and recording continues until you stop playback. When you stop adjusting the control, the control's last setting overwrites the existing envelope points/keyframes.

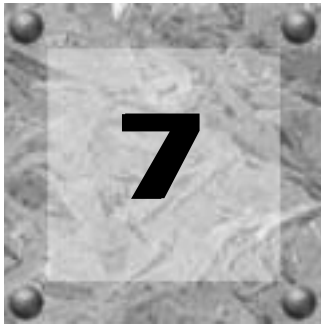

Working with Events

Events are windows into media files in a project and are the most basic unit of editing in Vegas® software. Media files that are inserted into the timeline are automatically contained within an event. Trimming and editing an event does not affect the source media file in any way.

Setting event switches

Event switches are important functions that are used to determine the basic behavior of events. You can set switches for a single event or multiple events at the same time.

1. Right-click an event.
2. From the shortcut menu, choose **Switches**, and choose the desired switch from the submenu.

Active switches have a check mark next to them. Choose an active switch on the menu to turn it off.

Tip: You can also set switches in the **Edit** menu, in the *Edit Details* window, or by right-clicking an event and choosing *Properties*.

Mute

Use the Mute switch to mute an event. This prevents the event from playing back.

Lock

The Lock switch locks an event to prevent it from being moved or edited.

Loop

You can loop an event so that you can extend it along the timeline by dragging the right edge of the event. Notches appear in the top of the event to mark where the media in the event ends and then repeats.

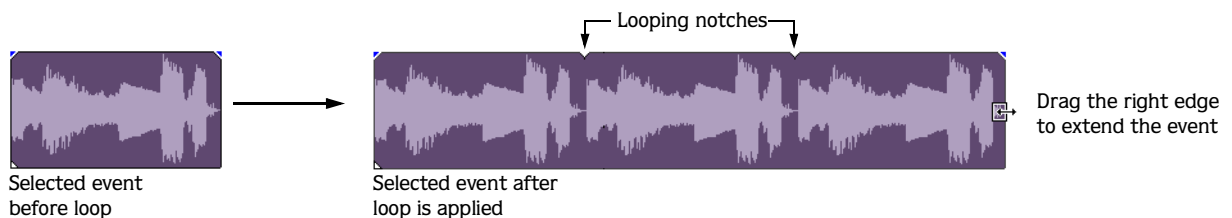

For video events, turning off the Loop switch makes the last frame repeat for the duration of the event beyond its original length, creating a freeze frame effect (as in the middle example below). The Loop switch is enabled for the event in the last example below.

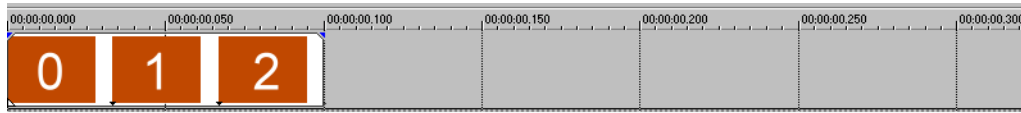

The original three frame clip.



Looping is off. The elongated event repeats (freezes) the final frame.



Looping is on. The entire event repeats.

Invert phase (audio only)

This switch inverts the audio event at its baseline, in effect reversing its polarity. Inverting an event, while creating no audible difference, is occasionally useful for matching transitions when mixing audio on separate tracks or fine-tuning a crossfade.

You can also phase invert a track. If a track is inverted and you invert an event on the track, the event is doubly-inverted (restored to its original state). For more information, see [Phase inverting a track \(audio only\)](#) on page 113.

Normalize (audio only)

You may normalize an event to maximize its volume, based on the waveform's highest peak, without clipping the event during playback.



Recalculating the normalization

When you normalize an event, the event is analyzed and the volume is raised based on the waveform's highest peak and then adjusts the rest of the event accordingly. If you have adjusted the edge of an event to exclude the (formerly) highest waveform peak, you may want to recalculate the event's normalization.

1. Right-click the event to display a shortcut menu.
2. From the shortcut menu, choose **Properties**.
The Properties dialog opens.

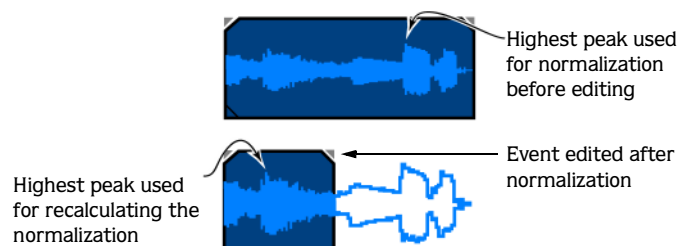

3. Click Re-calculate to normalize the event again.

Tip: You can set the maximum decibel level used to calculate the event during normalization. For more information, see [Audio tab](#) on page 291.

Maintain aspect ratio (video only)

Video and image files of various sizes and formats can be included in a single project. The project itself may have a different frame size aspect ratio from the source media files. This is not a problem, but you must specify how these differences are handled. If the length-to-width ratio of the source media and the project's frame size are the same (e.g., source media at 320x240 and project frame size of 640x480), no aspect ratio distortion occurs. If the ratios are not the same, the source material may become distorted (stretched or compressed). By maintaining the aspect ratio of the original, the video is kept from becoming distorted by letterboxing or pillarboxing around the edges. This is the default setting.

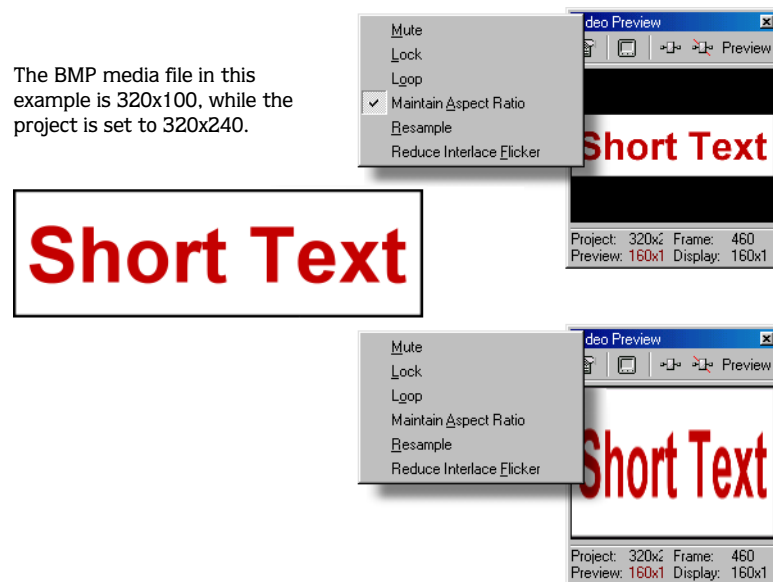

Reduce interlace flicker (video only)

This switch can be useful in cases where the source material didn't originate as video and contains extremely high spatial or temporal frequencies. When you watch the rendered (interlaced) output on video of this sort of media, you may see flickering or crawling edges if this switch is not applied.

Resample (video only)

Resampling allows Vegas software to interpolate frames in an event when the frame rate of a media file is significantly different from the project's frame rate. Resampling may solve some interlacing problems and other jittery output problems. For more information, see [Resampling video](#) on page 197.

Three options are provided for event-level resampling:

- **Smart resample:** Only resamples the event when the event frame rate does not match the project output frame rate. This can occur either because the event has a velocity envelope or because the frame rate of the original media is different than the project frame rate. **Smart resample** is the standard setting.
- **Force resample:** Always resamples the event, regardless of its frame rate or the project's frame rate.
- **Disable resample:** Does not resample the event.

Accessing event properties

The properties of an event are automatically determined based on the properties of the source media file. In addition to the event switches (mute, loop, etc.) described in the previous section, event properties include playback and undersample rates for video and pitch shifting for audio.

1. Right-click an event to display a shortcut menu.
2. From the shortcut menu, choose **Properties**. The Properties dialog appears.

The first tab in the dialog, either Audio Event or Video Event, contains the properties that are exclusively related to your Vegas project. The second tab, the Media tab, contains many properties that are an inherent part of the media file itself.

In addition to the event switches discussed in this chapter, event properties include the following:

- The Playback rate box sets the rate of playback. For example, a playback rate of 1 plays at normal speed, while a playback rate of 0.5 plays at half speed. *For more information, see [Time compressing/stretching events](#) on page 93.*
- The Undersample rate box allows you to simulate a lower frame rate. For example, an undersample rate of 0.5 plays the event at half its original frame rate. Each frame plays twice as long as in the original media file, creating a strobe effect.
- The Time stretch/pitch shift section of the dialog allows you to change the pitch, duration, or both pitch and duration of an audio event. *For more information, see [Pitch shifting audio events](#) on page 91.*

 *Pitch shifting while preserving length and time stretching while preserving pitch are only available in the full version of Vegas software.*

Adjusting audio channels

A stereo audio event has two channels: right and left. You can adjust how these channels are played by right-clicking an event, choosing **Channels** from the shortcut menu and choosing one of the following commands from the submenu:

- **Both** plays both channels in stereo. This is the default setting.
- **Left Only** plays only the left channel. Playback is mono and is centered between the two channels.
- **Right Only** plays only the right channel. Playback is mono and centered.
- **Combine** adds the two channels into a single channel and divides the level in half to prevent clipping. Playback is mono and is centered between the two channels.
- **Swap** exchanges the right and left channels (stereo playback).

You can also pan from one channel to the other using either the multipurpose slider or a pan envelope. *For more information, see [Adjusting stereo panning](#) on page 110.*

Copying and pasting event attributes

You've set up one event exactly the way you want it, and now you want to apply the same attributes to another event. A quick way to copy the attributes of one event and paste them onto another is provided.

You can copy and paste multiple event attributes, including:

- Properties (pg. 136), including audio pitch shift (pg. 91) and video playback rate (pg. 93)
- Switches (pg. 133)
- Video event plug-ins (pg. 205)
- Cropping (pg. 187)

1. Click the event with the attributes you wish to copy and click the Copy button ().
2. To paste the event attributes to multiple events, select the events. *For more information, see [Selecting multiple events](#) on page 60.*
3. Right-click an event and choose **Paste Event Attributes** from the shortcut menu. The attributes are pasted onto the selected event(s).

Using audio event envelopes (ASR)

You may apply envelopes to individual events. Envelopes, also known as ASRs (attack, sustain, and release), give you the ability to control an audio event's fade-in, fade-out, and overall volume level.

Note: *Event envelopes only affect an event. Track envelopes affect the entire track. For more information, see [Composite level automation \(video only\)](#) on page 124.*

When you add an event to your project, handles are added that are used to set the envelope. As you use these handles on audio events, a volume envelope appears indicating how the event is being affected.

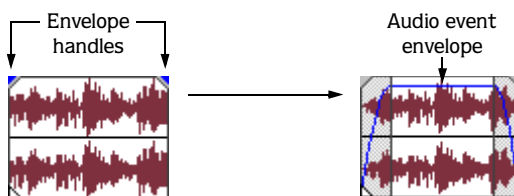

Setting an audio event's volume

When you place the mouse pointer at the top of the event, the pointer changes to a hand cursor () that you can use to lower the event's overall volume.

1. Place the mouse pointer at the top of the event.
2. When you see the envelope cursor (), drag the volume envelope to the desired level. As you drag, the event's decibel level is displayed.

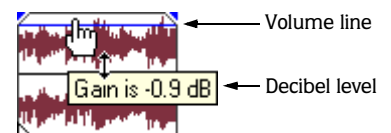

Note: *When you have multiple events selected, the gain of all selected events is adjusted simultaneously.*

Setting an event's fade in and out

The event handles allow you to change an audio event's fade in and out volume. You can also change the type of curve that the event uses to control the volume's fade in or out.

1. Place the mouse pointer on a handle (upper corners of the event). The pointer changes to the envelope cursor (↔).
2. As you drag, the volume envelope appears. Both the time in the event and the decibel level are displayed.

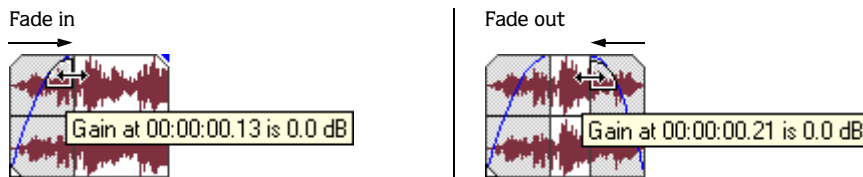

Changing an event's fade curve

You can set the shape of the fade curve (fast, linear, slow, sharp, or smooth) that an event uses to raise or lower the volume over time. To access the different fade curves, right-click anywhere in the event's fade-in or fade-out region and choose **Fade Type** from the shortcut menu.

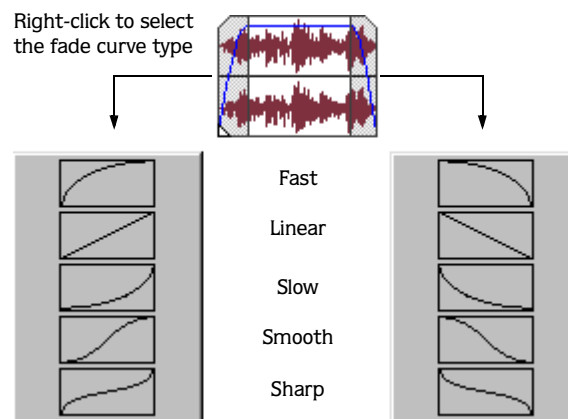

Tip: If you use the same fade curve frequently, you can set it as a default for all new audio event envelopes. For more information, see [Editing tab](#) on page 299.

Using video event envelopes

 *Velocity envelopes are only available in the full version of Vegas software.*

Video envelopes allow you to control an event's opacity or velocity over time. Envelopes appear as lines on an event. With a velocity envelope, you have the added control of being able to create and edit envelope points.

Note: *Event envelopes only affect an event. Track envelopes affect the entire track. For more information, see [Composite level automation \(video only\)](#) on page 124.*

Using opacity envelopes

Opacity envelopes set the overall opacity and allow you to fade video events in and out. This affects the transparency of the event in relation to background events on lower tracks. These background events can be other video events or background colors. For more information, see [Using generated media on page 211](#).

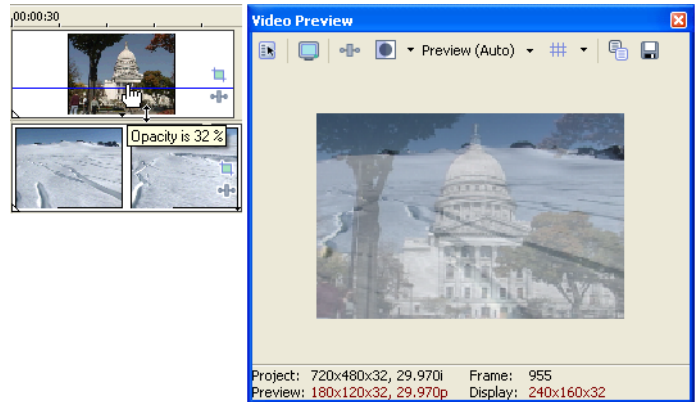

Setting a video event's opacity

When you place the mouse pointer at the top of the event, the pointer changes to a hand cursor (☞) that you can use to lower the event's overall opacity.

1. Place the mouse pointer at the top of the event.
2. When you see the envelope cursor (☞), drag the opacity envelope to the desired level. As you drag, the event's opacity level is displayed.

Note: When you have multiple events selected, the opacity of all selected events is adjusted simultaneously.

Setting an event's fade in and out

The event handles allow you to change a video event's fade in and out. You can also change the type of curve that the event uses to control the fade in or out.

1. Place the mouse pointer on a handle (upper corners of the event). The pointer changes to the envelope cursor (↔).
2. As you drag the cursor, the opacity envelope appears. Both the time in the event and the opacity level are displayed as you drag.

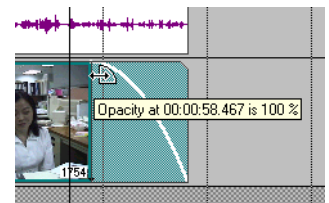

Changing an event's fade curve

You can set the shape of the fade curve (fast, linear, slow, sharp, or smooth) that an event uses to increase or decrease the opacity over time. To access the different fade curves, right-click anywhere in the event's fade-in or -out region and choose **Fade Type** from the shortcut menu.

Tip: If you use the same fade curve frequently, you can set it as a default for all new video event envelopes. For more information, see [Editing tab on page 299](#).

Using velocity envelopes

 Velocity envelopes are only available in the full version of Vegas software.

You can use velocity envelopes to change the speed of a video event over time. To view a velocity envelope, right-click the event and choose **Insert/Remove Velocity Envelope**.

1. Right-click an event and choose **Insert/Remove Velocity Envelope**. The velocity envelope appears on the event as a blue line.
2. To increase the speed, drag the envelope up. To slow the video down, drag the envelope down.

Adding velocity envelope points

When combined with points, envelopes can be used to animate velocity changes.

1. Double-click the envelope where you want to add a point.
2. Drag the point to adjust it. The time and velocity level of the point are displayed as you drag.
3. Right-click the envelope between two points to choose a fade type (linear, fast, slow, smooth, or sharp) to set the shape of the curve.

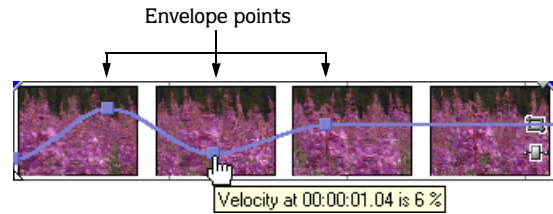

Tip: To delete a point, right-click the point and choose **Delete**.

Making a video play at twice its normal speed makes the duration of the video half as long. Likewise, slowing a video down makes it longer (with 0% being an infinite freeze frame). For example, if you decrease the speed of a ten-second video event by 50%, only five seconds of video play (played over the course of the ten-second event), meaning that only half as much actual footage from the original event plays. On the other hand, if the speed is increased 200%, the ten seconds of content play in only five seconds. The remaining five seconds of the event are filled either with a freeze of the last frame or with ten additional seconds of video content from the longer file.

You may want to resample the frame rate of an event that has been significantly slowed. To resample an event, right-click the event and choose **Properties**. Then, on the Video Event tab, select the Resample check box. For more information, see [Resampling video](#) on page 197.

Using the Envelope Edit Tool

While you can edit envelopes using the Normal Edit tool (⌘), you can limit your editing to envelopes only by clicking the Envelope Edit Tool button (⌘). You cannot move, trim, or otherwise modify events with this tool, which allows you to edit envelope points without making any other unwanted changes. For more information, see [Using the Envelope Edit tool](#) on page 128.

Reversing a video event

Setting the velocity to a negative value reverses the video, working backwards from the point where the negative value occurs. An event that has been reversed plays backwards until it gets to the first frame and then holds that frame for the duration of the event.

1. Right-click an event and choose **Insert/Remove Velocity Envelope**.
2. Trim the beginning of the video event to the place where you want the reversal to begin (e.g., the last frame in the media file that you want to play if it were playing forward).

3. Drag the velocity down to -100% for a normal speed reversal.



This is the original, untrimmed, event. The horses run from left to right.

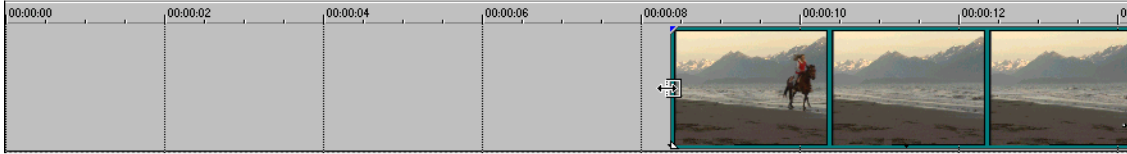

The event is edge trimmed to the frame where the reversal will begin.



The velocity envelope is added and set to -100%. The thumbnails reflect the change and the horses run backwards. The event can now be repositioned to fit the project.

Removing a velocity envelope

To remove a velocity envelope and all of its settings, right-click the event and choose **Insert/Remove Velocity Envelope** from the shortcut menu.

Grouping events

You are allowed to group events together within tracks or across separate tracks. Once you create a group, you can move all the events in the group within their tracks as a unit and apply event-specific edits at the same time.

You can still edit properties of individual events within a group without affecting the other events in a group.

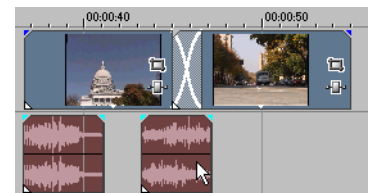

Dragging one event in a group moves all events in the group.

Creating a new group

Grouping is useful when you want to preserve timing of events and move events together along the timeline.

1. Select the events you want to group. *For more information, see [Selecting multiple events](#) on page 60.*
2. From the **Edit** menu, choose **Group**, and choose **Create New** from the submenu.

Adding an event to an existing group

1. Right-click an event in the existing group, choose **Group** from the shortcut menu, and choose **Select All** from the submenu to select all of the members of the group.
2. Press **Ctrl** and click the event to be added to the group.
3. Right-click the event, choose **Group** from the shortcut menu, and choose **Create New** from the submenu.

Note: *Events can only be in one group at a time. Adding an event to an existing group essentially clears the old group and creates a new one that includes all of the selected events.*

Removing events from a group

You can remove individual events from a group without affecting the other members of the group. An event you remove from the group is not deleted from the project and remains on the timeline.

1. Right-click the event you want to remove from the group.
2. From the shortcut menu, choose **Group**, and choose **Remove From** from the submenu. The event is removed from the group. The rest of the grouped events remain intact.

Clearing a group

You may ungroup all events by clearing the entire group. Clearing a group does not remove events from your project.

1. Right-click one of the members of the group.
2. From the shortcut menu, choose **Group**, and choose **Clear** from the submenu.

Selecting all members of a group

While grouped events move together within their tracks, selecting one member of a group does not automatically select every member of that group.

1. Right-click one of the members of the group.
2. From the shortcut menu, choose **Group**, and choose **Select All** from the submenu.

With all events in a group selected, you can move the group to other tracks, or cut and paste the group to a new location.

Suspending grouping temporarily

You can temporarily suspend the grouping behavior of all groups (including video media files with included audio streams) by clicking the Ignore Event Grouping () button.

Cutting, copying, or deleting grouped events

1. Select the events you want to cut or delete.
2. From the **Edit** menu, choose **Group**, and choose **Cut All**, **Copy All**, or **Delete All** from the submenu. The selected events and any events that are grouped with the selected events are deleted or copied/cut to the clipboard.



Using the Mixer

The Mixer window is where you control the project's busses and assignable effects chains.

 Multiple audio busses and assignable effects chains are only available in the full version of Vegas® software.

Using the Mixer window

The Mixer is a dockable window where you can control audio busses and assignable effects chains within your project and adjust the outgoing signal's volume and routing.

Viewing the Mixer window

The Mixer window appears in the window docking area by default when you first start Vegas software. However, you can drag the Mixer within the workspace at any time to float it. *For more information, see [Window docking area and floating window docks](#) on page 21.*



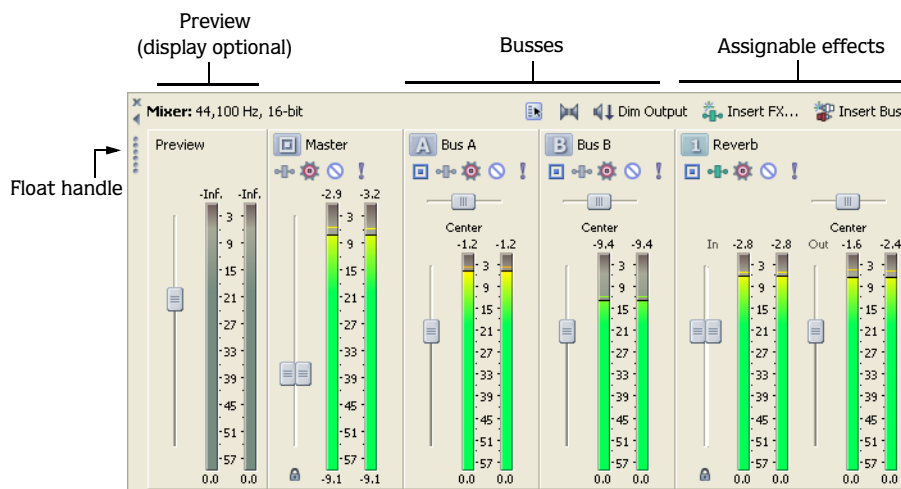





To hide/view the Mixer window, choose Mixer from the **View** menu or press **Alt** + **3**.



Using the Mixer toolbar

The Mixer's toolbar allows you to access project properties, add busses, and add assignable effects chains to the Mixer.

Mixer: 44,100 Hz, 16-bit    Insert FX... 

Button	Description
	The Project Audio Properties button accesses the project properties dialog (pg. 291).
	The Downmix Output button downmixes your audio from 5.1 surround to stereo or from stereo to mono so you can ensure your mix will sound the way you intended it, even when your audience's hardware has fewer channels than the original mix. The button represents the current playback mode:  5.1 surround output  Stereo output  Mono output
	The Dim Output button attenuates the volume of all busses that are routed to hardware outputs by 20 dB. Click again to restore original volume.
	The Insert Assignable FX button adds an assignable effects chain to your project. You can route tracks to the assignable effects chain (pg. 151).
	The Insert Bus button adds a bus to your project. You can route tracks or assignable effects chains to the bus (pg. 149).

Using the Mixer Preview fader

The Preview fader allows you to adjust the volume and monitor output levels of media files when you preview them from the Explorer window or Media Pool, or play them back from the Trimmer window. The Preview fader also controls the metronome volume. *For more information, see [Using the metronome](#) on page 167.*

Viewing/hiding the Preview fader

The Preview fader is hidden as a default to make more room for other busses and assignable effects chains. To view or hide the Preview fader, simply right-click anywhere within the Mixer and choose **Show Preview fader** from the shortcut menu.

Adjusting the Preview fader

You can adjust the Preview fader while you are previewing a media file from the Explorer window. Drag the fader up or down, or press **[Ctrl]** while dragging to move in smaller increments. Double-click the fader to reset it.

You can select a preferred meter resolution at which the Preview fader displays the media file's volume level. *For more information, see [Changing bus meter resolution](#) on page 148.* You can also adjust the Preview fader to correct clipping in the same way you adjust a bus. *For more information, see [Adjusting a bus for clipping](#) on page 148.*

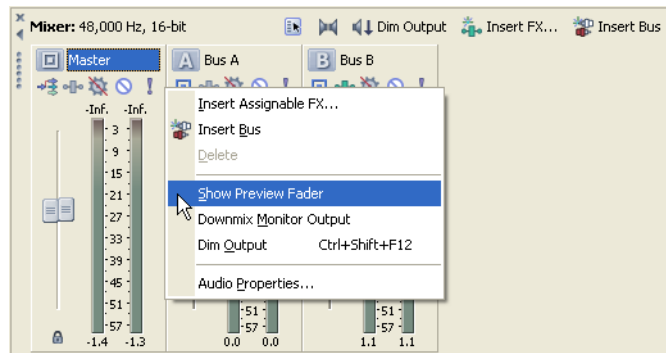



Using busses

 Multiple audio busses are only available in the full version of Vegas software.

A bus is a master control for the audio-signal mix of one or more tracks. You can assign tracks to play back on a specific bus. For more information, see [Assigning audio tracks to busses](#) on page 149.

However, to assign a track to a bus, you must have more than one bus in your project. Each project has a Master bus as a default, but you may add up to 25 additional busses to the Mixer window. A bus is the last stage in the signal's flow through Vegas software. For more information, see [Audio signal flow](#) on page 34.

You can configure each bus to use a specific hardware output. For more information, see [Audio tab](#) on page 297.

Automation settings	The controls in the bus control list can function as trim controls or automation controls for bus volume, panning, and muting. Click the button and verify Show Automation Controls is not selected if you want the bus control to function as a trim control. Adjusting a trim control affects the entire track. Click the button and choose Show Automation Controls to adjust automation settings. For more information, see Using Automation on page 119.
Mute	Prevents playback of the bus (pg. 148). When Show Automation Controls is selected, the button is displayed as a  , and you can use the button to edit mute automation on the bus's bus track.
Solo	Plays only the output of that bus (pg. 149).
Fader	Adjusts the bus's volume on two stereo channels (pg. 148). When Show Automation Controls is selected, the thumb is displayed as a  , and you can use the fader to edit volume automation on the bus's bus track. Tip: Right-click the thumb and choose Pre FX or Post FX from the shortcut menu to specify whether the bus level is applied before or after the bus effects chain.
Name	Name of the bus. Double-click the name to edit it (pg. 149).
Pan	Drag to adjust the overall panning of the track. When Show Automation Controls is selected, the thumb is displayed as a  , and you can use the slider to edit pan automation on the bus's bus track.
Playback device	Allows you to select the device that the bus uses for playback.
Bus FX	Displays the Bus FX window and allows you to adjust the audio effects plug-ins.
Meter	Displays the playback level of the bus (pg. 148).

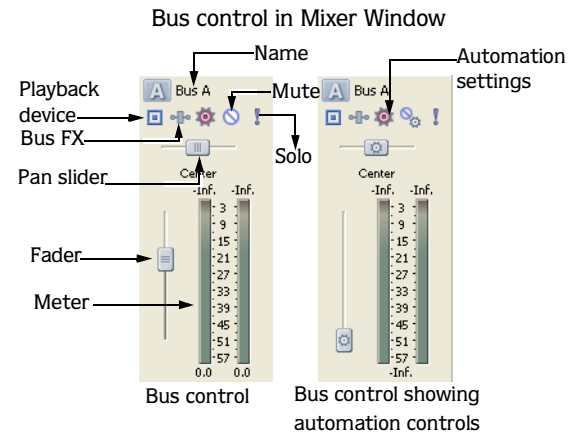

Adding busses to a project

You can add up to 25 busses at any time during the development of your project.

Adding a bus

Click the Insert Bus button () on the Mixer window.

Adding multiple busses

1. Click the Audio Properties button () on the Mixer window. The Project Properties dialog appears with the Audio tab displaying.
2. In the Number of stereo busses box, enter the desired number of busses (up to 25) to appear in the Mixer window.

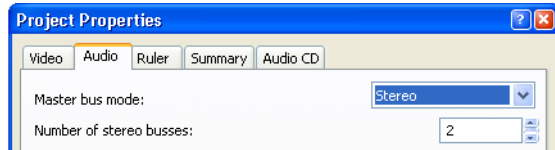

Enter the number of busses

3. Click OK to add the specified number of busses and close the Project Properties dialog. The new busses appear in the Mixer window.

Deleting busses from a project

You can remove busses from your project at any time. When you remove a bus from a project, any tracks assigned to it are reassigned to the Master bus.

Deleting a bus





Right-click the bus to be deleted in the Mixer window and choose Delete from the shortcut menu.

Deleting multiple busses

1. Click the Audio Properties button () on the Mixer window. The Project Properties dialog appears with the Audio tab displaying.
2. In the Number of stereo busses box, enter the desired number of busses to appear in the Mixer window.
3. Click OK. All tracks assigned to a deleted bus are reassigned to the Master bus in the Mixer window.

Routing a bus to another bus

If you have multiple busses, you can use bus-to-bus routing to create subgroups.

1. Add busses to your project. *For more information, see [Adding busses to a project](#) on page 145.*
2. In the Mixer window, click the Playback Device Selector button on the bus you want to route and choose a bus from the menu.
 - The button is displayed as a  when a bus is routed to the master bus.
 - The bus letter is displayed ( ,  , and so on) when a bus is routed to another bus.
 - The button is displayed as a  when a bus is routed to a hardware output.





Routing busses to hardware

You can assign busses to use specific hardware for output. When you installed the software, it automatically detected the hardware available for output on your computer. *For more information, see [Audio tab](#) on page 297.*

1. From the **Options** menu, choose **Preferences** and click the Audio device tab.

From the Audio device type drop-down list, choose Windows Classic Wave Driver or an ASIO™ driver.

Note: *If you select Microsoft Sound Mapper in the Audio device type drop-down list on the Audio tab, you will not be able to assign the bus to a different device.*

2. Click OK to close the Preferences dialog.
3. In the Mixer window, click the Playback Device Selector button on the bus you want to route.
4. Choose a hardware device from the menu.
 - The button is displayed as a  when a bus is routed to the master bus.
 - The bus letter is displayed ( ,  , and so on) when a bus is routed to another bus.
 - The button is displayed as a  when a bus is routed to a hardware output.

Note: *You can map multiple busses to a single sound card.*

Working with busses

Busses in the Mixer window are fully independent and may be adjusted separately. You can adjust the bus volume, change the bus meter resolution, and adjust the bus fader to eliminate clipping.



Adjusting bus volume

You can adjust a bus's volume during project playback by dragging the fader. The fader on a stereo bus is split so that you can adjust the levels of the two stereo channels independently.

The fader can function as a trim control that adjusts the overall level of the bus, or it can adjust volume automation settings on the bus track. Click the Automation Settings button  and verify **Show Automation Controls** is not selected if you want the fader to function as a trim control.

The faders are locked (ganged) so that the left and right channels of stereo files move together. Click the Lock/Unlock Fader Channels button () to unlock or lock the faders. You can also press **[Shift]** while dragging a fader to temporarily override a fader's locked or unlocked state.

Tip: Double-click a fader to reset it to 0.0 dB. If you have set each channel independently, double-click either the left or right fader to have the other fader match the other's volume setting.

If you want to adjust volume automation settings on the bus's bus track, click the Automation Settings button  and select **Show Automation Controls**. For more information, see [Adjusting volume or pan automation settings](#) on page 120. The fader handle is displayed as  in Automation mode.

You can adjust the volume of several busses simultaneously by selecting the busses and adjusting any of their faders. If you select an assignable effect along with the busses, the output fader of the assignable effect moves along with the bus volume faders.

Changing bus meter resolution

You can select a meter resolution at which a bus displays the signal levels that are being mixed. When you change the meter resolution on this control, the other meters (assignable effects and preview) automatically change to match.

To change bus meter resolution, right-click a meter and choose a meter resolution from the shortcut menu.



Adjusting a bus for clipping

If the volume level is set too high, it may cause clipping. The clipping displays in red at the top of the meter with the clipping value displayed in decibels (dB). Adjust the fader and click the red clipping value to reset the meter. Continue to adjust the fader and reset the meter until you eliminate the clipping.

You can set the meter to remember and display the highest and lowest levels by right-clicking and selecting **Hold Peaks** and **Hold Valleys**.

Muting a bus

Muting allows you to temporarily suspend playback of the bus. When a bus is muted, the word *Muted* appears at the bottom of the meter. You can mute more than one bus at a time.

The Mute button can mute the bus, or it can adjust mute automation on the bus's bus track. To mute the bus, click the Automation Settings button  and verify **Show Automation Controls** is not selected. Click the Mute button () to mute the bus, and click it again to restore playback.

To adjust mute automation, click the Automation Settings button  and select **Show Automation Controls**.

The Mute button is displayed as  in Automation mode. Click to turn mute automation on, or click it again to turn mute automation off. For more information, see [Adding or removing mute automation](#) on page 120.

Soloing a bus

Soloing isolates a bus's playback so that you can focus on a specific output. You can solo more than one bus at a time. To solo the bus, click the Solo button (ⓘ). Click the button again to turn off soloing.

Naming or renaming a bus

Every bus in the Mixer window has an editable name.

1. Double-click the bus name.
2. Type a new name.
3. Press **Enter** to save the name.

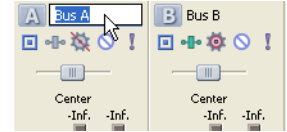

Panning a bus

Like volume, the pan slider in the track header can function as a trim control that adjusts the overall panning of the track, or it can adjust track panning automation settings. *For more information, see [Adding or removing volume or pan automation](#) on page 120.*

Assigning audio tracks to busses

If your project contains multiple busses, you can assign a track to a specific bus. *For more information, see [Assigning audio tracks to busses](#) on page 111.*

 *Multiple audio busses are only available in the full version of Vegas software.*

Adjusting a bus send level



You can adjust the level of a track sent to a bus by using the multipurpose slider in the track list. *For more information, see [Assigning audio tracks to busses](#) on page 111.*

Using assignable effects chains

Assignable effects are only available in the full version of Vegas software.

Assignable effects allow you to send various levels of multiple tracks to a single audio effect chain. Like busses, these controls reside in the Mixer window and support plug-in chains. In addition, you can route assignable effects outputs to project busses.

Click the Insert Assignable FX button (🔧) in the Mixer window to add an assignable effects chain to your project. For more information, see [Adding Audio Effects on page 153](#).

Number/Name	Number and name of assignable effects. Double-click the name to edit it.
Automation settings	The controls in the assignable effects control list can function as trim controls or automation controls for output level, panning, and muting. Click the button and verify Show Automation Controls is not selected if you want the bus control to function as a trim control. Adjusting a trim control affects the entire track. Click the button and choose Show Automation Controls to adjust automation settings. For more information, see Using Automation on page 119 .
Mute	Prevents the assignable effects chain from processing the track's signal. When Show Automation Controls is selected, the button is displayed as  , and you can use the button to edit mute automation on the chain's bus track.
Solo	Plays only the output of that assignable effects chain.
Assignable FX	Displays the Assignable FX window and allows you to adjust the plug-in settings.
Bus Pan	Drag to adjust the overall panning of the assignable effects chain. When Show Automation Controls is selected, the thumb is displayed as  , and you can use the slider to edit pan automation on the chain's bus track.
Bus assignment	Allows to you assign the assignable effects chain to a bus.
Input Fader	Adjusts the input volume.
Output Fader	Adjusts the output volume. When Show Automation Controls is selected, the thumb is displayed as  , and you can use the fader to edit volume automation on the chain's bus track.
Meter	Displays the incoming and outgoing signal level to the assignable effects chain.
Lock/Unlock Fader Channels	Locks the faders so the left and right channels of stereo files always move together. Click again to unlock the faders.

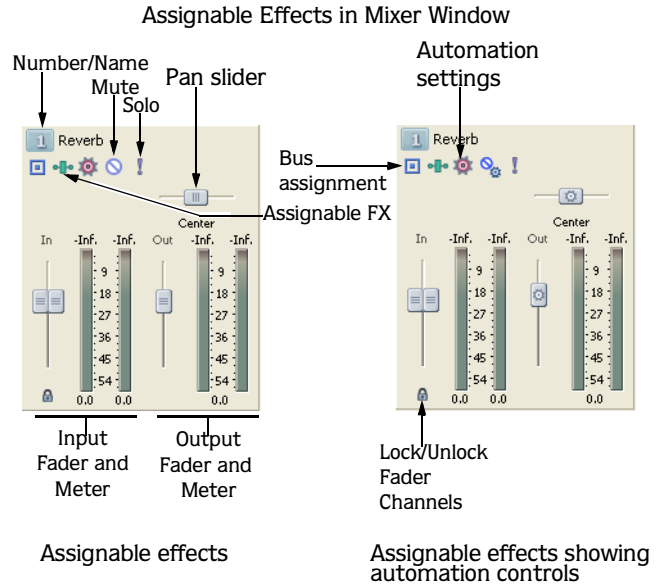

Tip: To use the output fader to control the wet/dry mix of the assignable effects chain, set each plug-in to 100% wet. Use the output (effects return) fader to balance the dry track signal with the wet plug-in signal.

You can work with assignable effects controls in much the same way you work with busses. Use the same methods described earlier in this chapter for adjusting volume, adjusting for clipping, muting, soloing, and renaming. For more information, see [Working with busses](#) on page 148.

Assigning audio tracks to assignable effects chains

 Assignable effects are only available in the full version of Vegas software.

You can adjust the level of a track that is sent to an assignable effects chain using the multipurpose slider in the track list. For more information, see [Assigning audio tracks to assignable effects chains](#) on page 111.

Routing assignable effects chains to busses

When you add assignable effects to your project, you can assign them to a specific bus for output. The bus mixes the assignable effects chain's plug-ins along with any tracks that may be routed to the same bus. For more information, see [Audio signal flow](#) on page 34.

This option is only available if the project contains multiple busses. For more information, see [Adding busses to a project](#) on page 145.

1. Click the Bus button () on the assignable effect control. A menu displays all the busses in your project.
2. Choose the bus to which you want to route the assignable effects chain.

The assignable effects chain displays the letter of the bus to which it is routed.

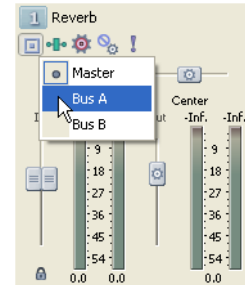

Automating busses and assignable effects

You can automate busses and assignable effect chains in the track view. You can view each of these controls on bus tracks at the bottom of the track view and to add envelopes to automate functions such as volume, pan, and assignable effect chain input/output levels. For more information, see [Using Automation](#) on page 119.

If you have the full version of Vegas software, you can also add envelopes to automate effect parameters for plug-ins that support automation. For more information, see [Adding or removing effect automation envelopes](#) on page 122.

Viewing bus tracks

From the **View** menu, choose **Show Bus Tracks** or press **[U]**. The bus tracks appear at the bottom of the track view. A bus track appears for each bus or assignable effect chain in your project.

Adding track envelopes

Right-click the track header in the track list, choose **Insert/Remove Envelope** from the shortcut menu, and choose the appropriate envelope type from the submenu.

Modifying track envelopes

You can modify a track envelope for a bus or assignable effect in the same way you do with any other track. For more information, see [Working with track envelopes](#) on page 126.



Adding Audio Effects

You can use audio effects, or plug-ins, to improve the quality of the audio in a production or to create special artistic effects. In addition to the DirectX® plug-in effects included with Vegas® software, you can also use other Sony Pictures Digital plug-ins and third-party plug-ins.

Using audio effects

There are three ways to use audio plug-ins: track effects, bus effects, and assignable effects. You can access these plug-ins by clicking the Track FX, Bus FX or Assignable FX buttons (). The combination of these various methods of applying audio effects is important to the final mix of a project. *For more information, see [Audio signal flow](#) on page 34.*

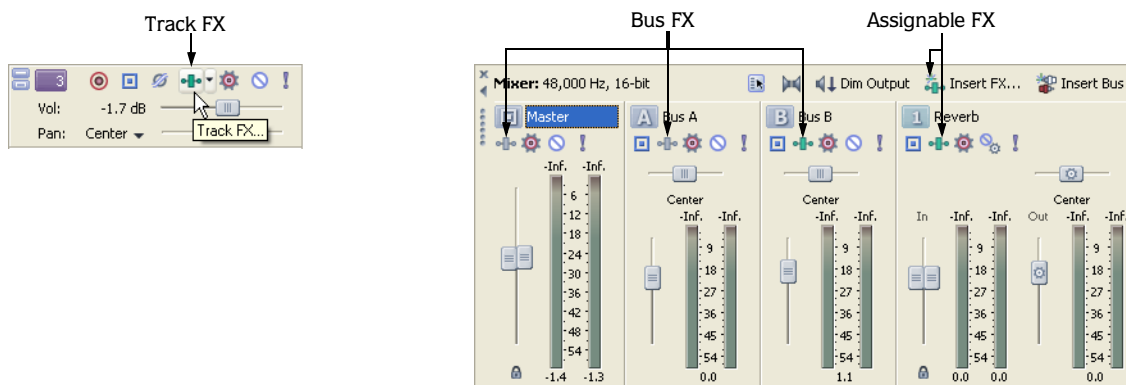

- **Track effects** are applied to all events in a single track.
- **Bus effects** are applied to a bus (including the Master bus). When you add plug-ins to a bus, the tracks that are assigned to the bus are processed by the plug-in(s). Since multiple tracks can be assigned to a single bus, using bus-level audio effects is an efficient method of applying carefully customized chains of audio effects to multiple tracks. If plug-ins are assigned at the track level, the track's signal flows through the track's plug-in(s) before the bus plug-ins. *For more information, see [Using busses](#) on page 145.*
- **Assignable effects** allow you to send various levels of multiple tracks to a single effect chain. Like busses, these controls reside in the Mixer window and support plug-in chains. In addition, assignable effects outputs can be routed to busses. Click the Insert Assignable FX button () in the Mixer window to add an assignable effect chain to your project. *For more information, see [Using assignable effects chains](#) on page 150.*

Using plug-in chains

A plug-in chain is a sequence of plug-ins to be applied to tracks, busses, or assignable effects. A plug-in chain can contain one or more plug-ins. The same plug-in can be added to a chain more than once.

After the plug-in chain is created, the audio is processed by each plug-in in order. The plug-ins are cumulative so, in some cases, you may want to rearrange their order to achieve the desired effect.

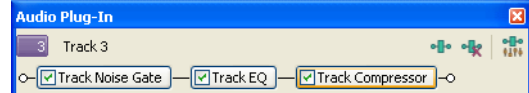

Plug-ins in a chain

*If you're working with a 5.1 surround project, you can use distinct plug-in settings for each channel (separate EQ settings for the front and surround speakers, for example) using effect automation. Add multiple instances of the plug-in to the track effects chain and select the **Enable** check boxes in the FX Automation Chooser for the channels you want each instance of the plug-in to affect.*

Creating a plug-in chain

Audio tracks have a built-in plug-in chain with three default plug-ins applied as a default. For bus effects and assignable effects, however, you must first create a plug-in chain.

Creating a bus effects plug-in chain

1. Click the Bus FX button (+) on a bus in the Mixer window. The Plug-In Chooser dialog appears.
2. Select a plug-in and click OK. The Audio Plug-In window displays with your selected plug-in as the first in the new plug-in chain.
3. Adjust the settings for the plug-in to create the desired effect and click the Close button (X) in the upper-right corner to close the window.

Creating an assignable effects plug-in chain

1. Click the Insert Assignable FX button (+) on the Mixer window. The Plug-In Chooser dialog appears.
2. Select a plug-in and click OK. The Audio Plug-In window displays with your selected plug-in as the first in the new plug-in chain.
3. Adjust the settings for the plug-in to create the desired effect and click the Close button (X) in the upper-right corner to close the window. The new assignable effect control appears in the Mixer window.

Adding plug-ins to a plug-in chain

There are two ways to add plug-ins to a chain: via the Plug-In Chooser dialog and via the Audio Plug-In window.

Adding plug-ins via the Plug-In Chooser dialog

You can access the Plug-In Chooser dialog from the track, bus, or assignable effects chain to which you are adding the plug-in.

1. Click the Track FX, Bus FX or Assignable FX button (+). The appropriate FX window (Audio Plug-In or Video Track FX) appears.

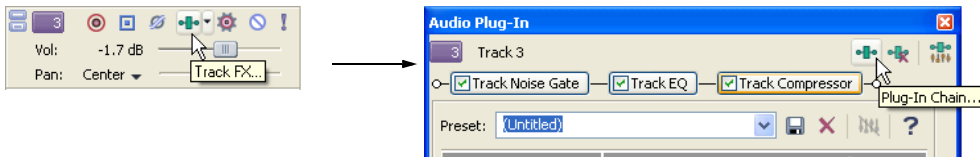

2. Click the Plug-In Chain button (+) on the window. The Plug-In Chooser dialog appears. Plug-ins already in the chain appear at the top of the dialog.

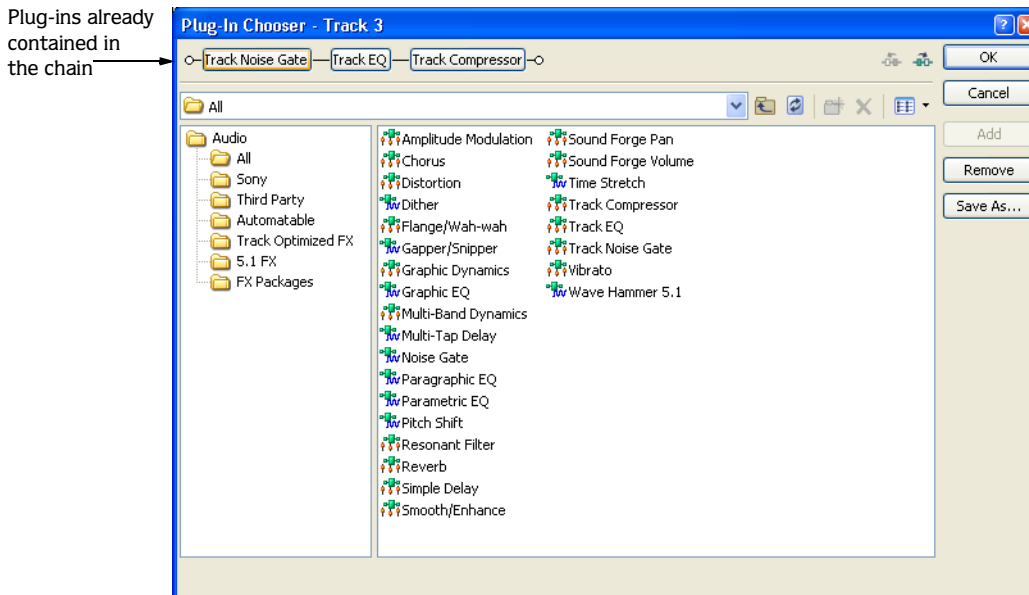

3. Select a plug-in and click Add.
4. Repeat step three to add as many plug-ins as you need to create the desired effect.
5. Click OK to close the Plug-in Chooser dialog. The plug-in chain appears just below the title bar in the appropriate FX window (Audio Plug-In or Video Track FX).

Adding plug-ins via the Plug-In Manager

The Plug-In Manager is a dockable window that allows you to view and choose plug-ins to be added to a track, bus, or assignable effects chain.

1. If the Plug-In Manager is not displayed, press **Ctrl + Alt + 1**.
2. In the Plug-In Manager, navigate to the Audio folder and select one of the FX folders.

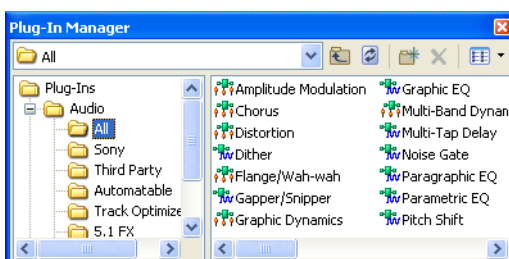

3. Drag a plug-in to a track, bus, or assignable effects chain.

Tip: You can select multiple plug-ins and add them at the same time by dragging them to the desired location.

4. Confirm that the plug-ins were added by clicking the Track FX, Bus FX or Assignable FX button (•+) to view the appropriate FX window (Audio Plug-In or Video Track FX). You can customize the settings for the effects at this time.

Saving customized plug-in presets

Each plug-in has a number of presets that you can use to set the behavior of the plug-in. However, you can also adjust the controls for the plug-in manually to create custom settings. You can then save the effect settings as a new preset.

1. Click the Track FX, Bus FX or Assignable FX button (•+). The appropriate FX window (Audio Plug-In or Video Track FX) appears.
2. In the plug-in chain at the top of the window, click the plug-in you want to customize.
3. Adjust the settings for the effect.
4. Enter a preset name in the Preset box.
5. Click the Save button (📁) to save the preset.

Tip: You can delete a saved preset by selecting it from the list and clicking the Delete button (✕).

Arranging the order of plug-ins

Plug-ins are cumulative during playback. Because of this cumulative effect, you may need to arrange plug-ins in a certain order so that one plug-in's processing does not adversely affect the next plug-in on the chain. There is no right or wrong way to order plug-ins, but some plug-ins work better when arranged in a particular order.

You can arrange the order of plug-ins in a chain in either the appropriate FX window or the Plug-In Chooser dialog.

Arranging the plug-in order in the FX window

1. Click the Track FX, Bus FX or Assignable FX button (•+). The appropriate FX window (Audio Plug-In or Video Track FX) appears.
2. On the plug-in that you want to move, right-click and choose **Move Left** or **Move Right** from the shortcut menu. Alternately, drag a plug-in to a new position.

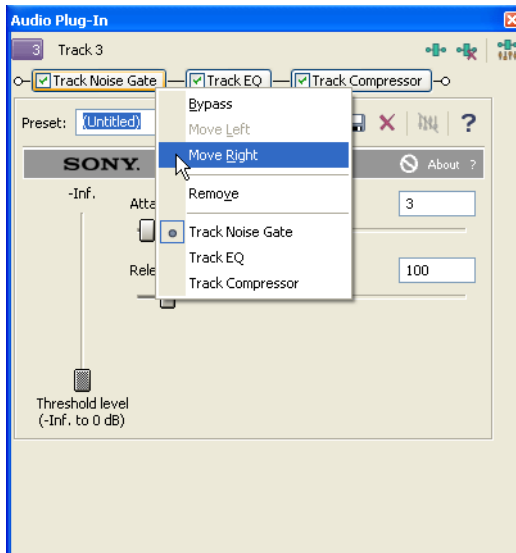

3. Once the chain's plug-ins are in the order that you want, click the Close button (✖) in the upper-right corner to close the window.

Arranging the plug-in order from the Plug-In Chooser dialog

1. Click the Track FX, Bus FX or Assignable FX button (⊕). The appropriate FX window (Audio Plug-In or Video Track FX) appears.
2. Click the Plug-In Chain button (⊕). The Plug-In Chooser dialog appears with the plug-in chain displayed at the top.
3. Drag a plug-in to a new location in the chain, or select a plug-in and click either the Shift Plug-In Left (⇐) or Shift Plug-In Right (⇒) button.
4. Click OK to close the Plug-In Chooser dialog.

Bypassing plug-ins on the chain

You can bypass plug-ins on the chain by clearing the check box on a specific plug-in or by right-clicking the plug-in and choosing **Bypass** from the shortcut menu. The plug-in remains bypassed until you enable it again. Bypassing a plug-in prevents it from being processed on the mixer, track or bus.



To enable the plug-in again, click its check box or choose **Bypass** from the shortcut menu.

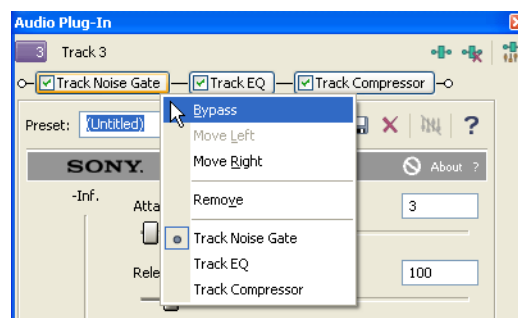

You can bypass plug-ins from the appropriate FX window or from the Plug-In Chooser dialog.

Removing plug-ins from a chain

You can remove plug-ins from a chain in either the appropriate FX window or the Plug-In Chooser dialog.

Removing a plug-in from the chain in the FX window

1. Click the Track FX, Bus FX or Assignable FX button (•+). The appropriate FX window (Audio Plug-In or Video Track FX) appears.
2. Select the plug-in that you want to remove.
3. Click the Remove Selected Plug-In button (•+).

Removing a plug-in from the chain in the Plug-In Chooser dialog

1. Click the Track FX, Bus FX or Assignable FX button (•+). The appropriate FX window (Audio Plug-In or Video Track FX) appears.
2. Click the Plug-In Chain button (•+). The Plug-In Chooser dialog appears with the plug-in chain displayed at the top.
3. Select the plug-in that you want to remove and click Remove to remove it from the chain.
4. Click OK to close the Plug-In Chooser dialog.

Saving plug-in chains

You can save and edit the plug-in chains that you add to tracks or busses or create as assignable effects chains. Saved chains retain the order of plug-ins and the settings that you have applied. These chains are stored as effect packages for use in future projects. If you use the same plug-in chains regularly, saving them as packages is faster and more consistent than recreating the chain manually.

Once you save a chain as a package, you can use it as either a track, bus or assignable effects plug-in chain. Saved plug-in chain packages appear in the Plug-In Chooser dialog.

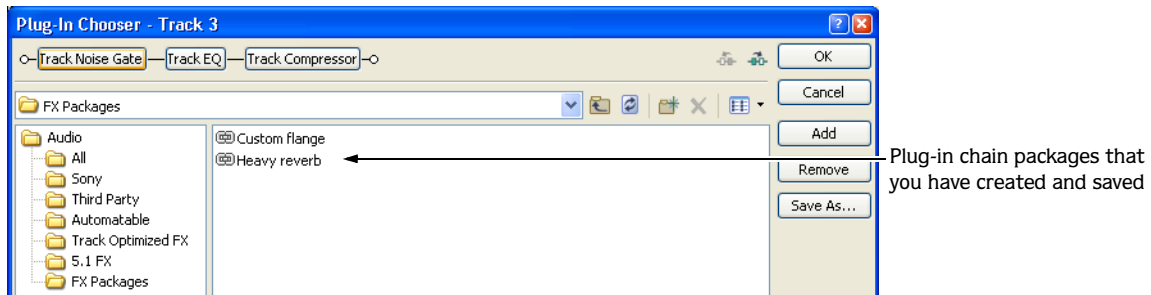

1. Click the Track FX, Bus FX or Assignable FX button (•+). The appropriate FX window (Track FX, Bus FX, or Assignable FX) appears.
2. Click the Plug-In Chain button (•+). The Plug-In Chooser dialog appears with the plug-in chain displayed at the top.
3. Click Save As. The Save Plug-in Package dialog appears.
4. Enter a name for the package.
5. Click OK or press **Enter** to save the package.

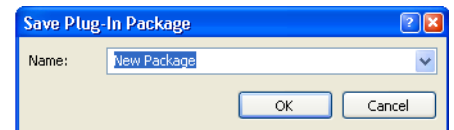

Editing saved plug-in chains

You can add, delete, or rearrange plug-ins in a saved package at any time. You can then save your changes to the package, or enter a new name to save the chain as a new package.

1. Click the Track FX, Bus FX or Assignable FX button (•+). The appropriate FX window (Audio Plug-In or Video Track FX) appears.
2. Click the Plug-In Chain button (•+). The Plug-In Chooser dialog appears with the package in the chain area.
3. Add, delete, rearrange, or change the settings of plug-ins in the package chain.
4. In the Plug-In Chooser dialog, click Save As to save the modified package.
5. To save the package with a new name, enter a name in the Name box. To save the changes to the existing package, choose the name of the package from the Name drop-down list.
6. Click OK or press **Enter** to save the new settings.

Organizing your plug-ins

Within the Plug-in Chooser dialog, you can create folders to organize the plug-ins. This can help you organize large numbers of plug-ins on your system. You can create folders and then drag plug-ins to the folders.

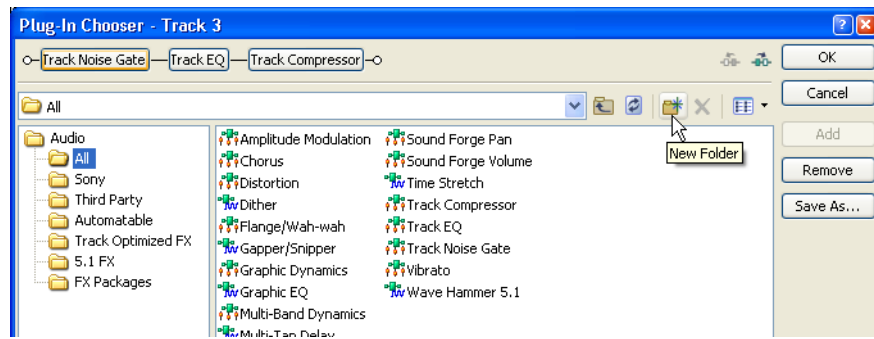

Automating effects parameters

Automation allows you to control audio and video levels, panning, and effect parameter automation over time. You can create fades, apply stereo panning, and add effects that come and go as you please. Automation is represented on the Vegas timeline as an envelope or set of keyframes. You can create automation by adding envelopes or keyframes to your tracks (including bus tracks), or you can record automation parameters by adjusting controls in the Vegas interface (or on a control surface) during playback. For more information, see [Using Automation](#) on page 119.

Applying non-real-time event effects

Non-real-time event effects are a different method of applying audio effects. In all other cases, event editing is nondestructive, meaning that edits and effects are applied to events in real time and not to the source media files, which remain unaltered. There may be times, however, when you want to create a permanent file using an effect or effects. This may be useful in a very complicated project or when a slower computer cannot process the effects quickly enough for a real-time preview.

By applying non-real-time event effects, you can make a new copy of a media file with the effects applied to it. This new media file is saved and added to the project as a take. For more information, see [Working with takes](#) on page 94.

1. Select an audio event.
2. From the **Tools** menu, choose **Audio**, and choose **Apply Non-Real-Time Event FX** from the submenu.
3. In the Plug-In Chooser dialog, add plug-ins to create a plug-in chain. For more information, see [Adding plug-ins via the Plug-In Manager](#) on page 155.
4. Click OK.
5. In the Take window, adjust the settings for the plug-in(s) to create the desired effect.
6. Preview the effect by clicking the Preview button (▶) in the Non-Real-Time Event FX window.

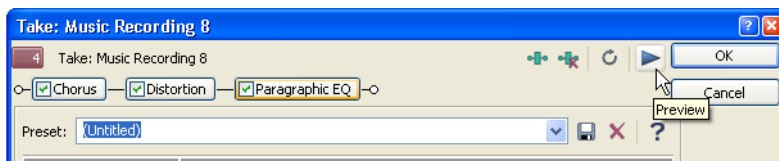

7. Click OK.
8. In the Take dialog, click Save to save the newly processed media file.

The new media file is saved and added to the project as a take.

Bypassing all audio effects

From the **Options** menu, choose **Bypass All Audio FX** to omit all audio effects (track, bus, and assignable effects) during playback.

Bypassing effects allows you to quickly compare your project with and without effects and conserve processing power to avoid playback problems.

When effects are bypassed, you can choose whether bypassed effects remain open. When the *Keep bypassed FX running* check box on the *General* tab of the *Preferences* dialog is selected, effects remain open so you can bypass/enable effects with no pause for A/B testing. When the check box is cleared, effects are fully bypassed, conserving processing power.

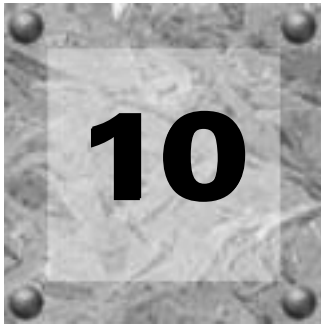

Recording Audio

Vegas® software can record audio into multiple mono or stereo audio tracks while simultaneously playing back existing audio and video tracks. You are limited only by the performance of your computer system and audio hardware. Audio is recorded to a media file on your computer and into an event on the timeline. You may record into an empty track, a time selection, an event, or a combination of time and event selection. Audio output from your computer during recording is not necessarily recorded with the new audio.

Recording does not alter any of the source media files in your project. Even when recording into an existing event, you are not overwriting the data in that event. Instead, the data is recorded into a new take for that event and saved to a media file on your hard drive.

Setting up your equipment

There are numerous ways to connect your equipment to your system. Refer to your equipment's documentation for specific setup instructions. The following are some possible general configurations.

Basic setup

This setup includes a simple microphone and speaker that are connected to the computer's sound card. With a more sophisticated microphone, you would typically want to use a preamplifier for input to the sound card.

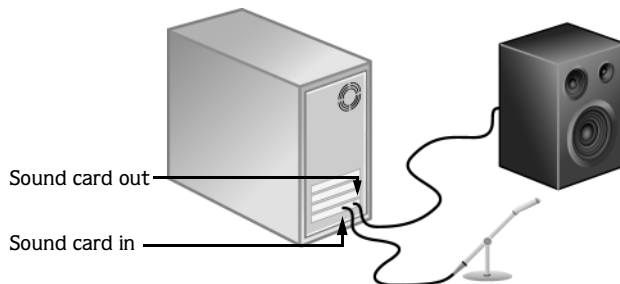

Setup with mixer

This setup includes a mixer where the speaker and microphone connect. The mixer is then connected to the computer's sound card. Mixers usually have pre-amps built into them. This diagram does not show you an instrument or a physical preamplifier, such as a rack-mounted component. The reason for this omission is because these types of setups vary widely based on your mixer, instrument, and pre-amp type. Refer to your components' documentation for specific setup configurations.

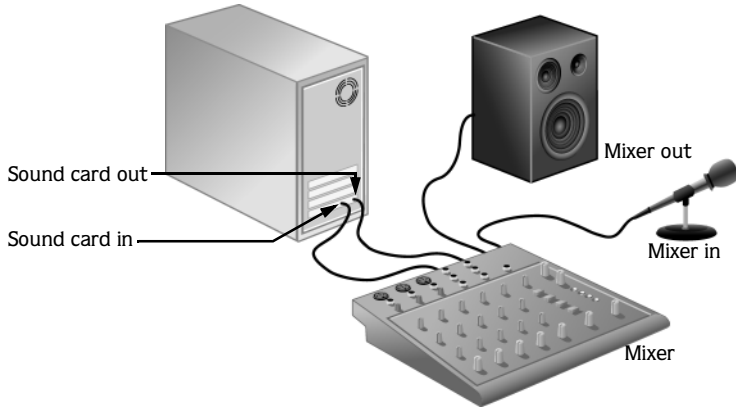

Setup with digital multitrack

This setup includes a digital multitrack recorder with an optional MIDI synchronization component. Usually you would have a mixer, a microphone, etc. connected to these components. Your particular setup will vary depending on your equipment. Refer to your components' documentation for specific setup configurations.

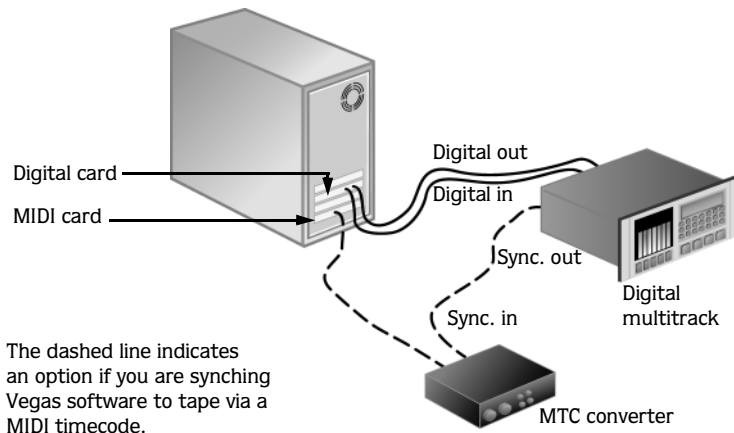

Synchronizing MIDI timecode

Vegas software can generate (output) MIDI timecode to synchronize external devices with project playback or can be triggered by MIDI timecode generated by an external device. To output MIDI, from the **Options** menu, choose Timecode, and choose **Generate MIDI Timecode** from the submenu. To allow Vegas software to be triggered by an external MIDI device, choose **Trigger from MIDI Timecode** from the same submenu. For more information, see [Triggering from MIDI timecode](#) on page 170 and [Sync tab](#) on page 301.

Preparing to record

Before you record, you must arm the tracks into which you will record the new audio. You must also select the recording settings for the tracks. You have the additional options of using a metronome or turning off playback during recording.

You may record into an empty track, a time selection, an event, or a combination of time and event selection. You can also record multiple takes for an event so you can maintain multiple versions of an event that you may play back and edit.

Tip: Select a media bin before recording if you want to automatically add your recorded audio to a media bin. To save track effects with your recorded files, create an effects package of the track effect settings and apply the chain to the event as a non-real time event effect.

Arming the track for recording

Whether recording into an existing track, an empty track, a selected event, or a time selection, you must prepare a track for recording. You can arm multiple tracks prior to recording.

1. Click the Arm for Record button (🎯) in the track list.

The first time you arm a track to record in a project, the Project Recorded Files Folder dialog displays.

2. Browse to the location where you want to save your recorded audio files.
3. Click OK.



Tip: You can change the location where recorded files are saved at any time. For more information, see [Specifying where recordings are stored](#) on page 170.

Once a track is armed, a record meter appears in the track list. Depending on your hardware, a record gain fader may also appear.



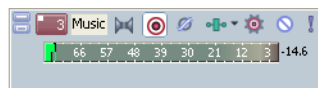

Arm the track first.



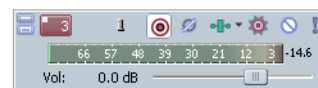





Track is ready for recording using the Sound Mapper.



Track is ready for recording from a specific device.

In addition, one of two Record Device Selector buttons appears: () or (). The button that appears is based on the Audio device type selected in the Audio tab of the Preferences dialog. For more information, see [Audio tab on page 297](#).

Button	Description
 Stereo	This button appears when Use Microsoft® Sound Mapper™ has been selected as the audio device type on the Preferences Audio tab. The Sound Mapper allows you to choose how the signal will be recorded: stereo or mono. Click this button to view a menu with Stereo, Left, or Right.
 Mono left	
 Mono right	
 Stereo	This button appears when Windows® Classic Wave Driver has been selected as the audio device type on the Preferences Audio tab. When you choose this option, you can specify which device (e.g., sound card) you will record from on any given track prior to recording. Click this button to view a menu with Stereo or Mono, and a submenu with all available devices for either option.
 Mono left	
 Mono right	

Selecting recording settings

After the track has been armed for recording, select whether the track records the signal in stereo, in mono from the left channel, or in mono from the right channel. If you are using the Microsoft® Windows® Classic Wave Driver, you also must select the device from which the track will record.

Selecting recording settings for Sound Mapper

1. Click the Record Device Selector button (). A menu appears.
2. From the menu, choose the recording method (Stereo, Left, or Right).

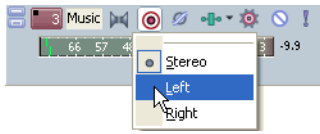

Selecting recording settings for Windows Classic Wave Driver.

1. Click the Record Device Selector button (). A menu appears.
2. Choose either **Stereo** or **Mono** from the menu.
3. From the submenu, choose the input device

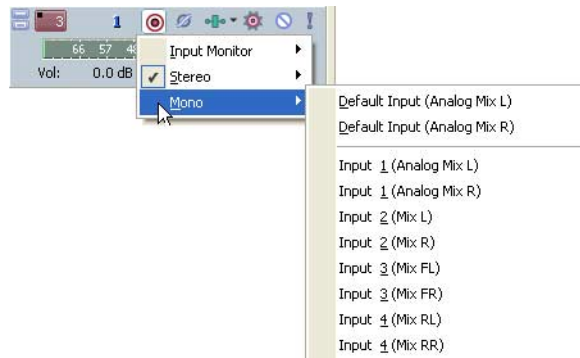

Using the metronome

A built-in metronome marks time to help with the timing and tempo when recording a performance. The metronome's sound is not mixed in the final rendering of the project. Use the Preview fader in the Mixer window to control the metronome volume. *For more information, see [Using the Mixer Preview fader](#) on page 144.*

To use the metronome, from the **Options** menu, choose **Metronome**.

Tip: You can customize the sound of the metronome in the Audio tab of the Preferences dialog. *For more information, see [Audio tab](#) on page 297.*

Recording

You may record into an empty track, a time selection, an event, or a combination of time and event selection. The recording is added to the timeline as new take and saves it to a media file on your hard drive.

Triggering recording from MIDI timecode is also supported.

Recording into an empty track

1. Select a track. Alternately, to record to a new track, choose **Audio Track** from the **Insert** menu.
2. Place the cursor on the timeline where you want to begin recording.
3. Arm the track by clicking the Arm for Record button (🎯) on the track.

If this is the first time you arm a track for recording in this project, you will be prompted to identify the location where the new audio files will be saved. *For more information, see [Arming the track for recording](#) on page 165.*

4. Start recording by clicking the Record button (🎙️) on the transport bar.

Depending on the recording selection, a waveform is created along the timeline as you record into the armed track(s).

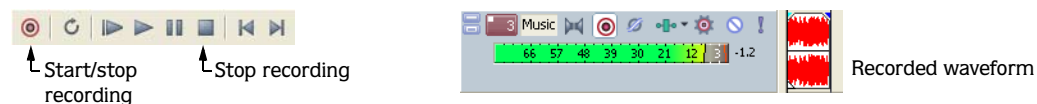

5. Stop recording by clicking the Record button (🎙️) again or the Stop button (⏏️) on the transport bar.
6. A small dialog opens displaying the name and location of the file or files that were just created. Click Done to return to the main workspace.

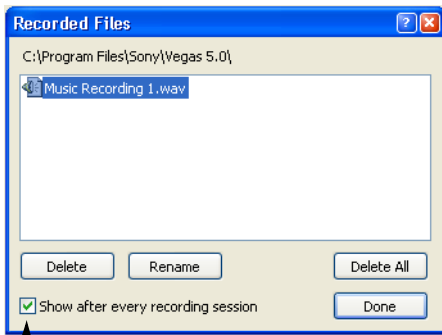

When a check mark appears in this box, Vegas software displays this dialog after each recording session.

Delete—removes selected file
 Rename—changes the name of a selected file
 Delete All—removes all files in dialog
 Done—returns to track view

Note: The Recorded Files dialog does not appear if you are triggering from MIDI timecode, as this would interrupt the synchronizing. Instead, files are automatically named and saved according to your preferences.

Recording into a time selection

By making a time selection, you specify where along the timeline to record. The time selection also determines how long the software records. Any selected events that occur within the time selection are split and the recorded data is placed into the time selection.

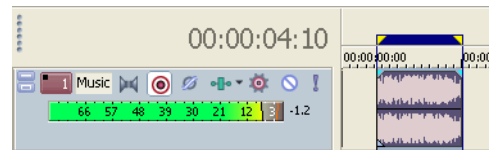

Recorded waveform

The event's waveform is displayed as it is recorded and automatically stops recording when the cursor reaches the end of the time selection.

Recording into an event

By recording into an event, you automatically create a new take containing the recorded material that is the same duration as the selected event. The edges of the selected event serve as the punch-in and -out points that are used for recording. Recording into an event allows you to establish a pre-roll before recording, which gives you time to prepare before recording starts.

Because the entire recording is saved to the media file (not just the material between the edges of the take), you are not limited to the recorded material contained in the length of the new take. You can adjust the edges of the event or slip the contents of the event if necessary. *For more information, see [Shifting the contents of \(slipping\) an event](#) on page 71.*

The existing event that you record into is not affected or deleted. Instead, the event now contains two media files, each listed as a separate take in the event. *For more information, see [Working with multiple recorded takes](#) on page 170.*

1. Place the cursor before the event to allow for pre-roll.
2. Press **Ctrl** and click the event to select it.

Tip: You can record into multiple events by pressing **Ctrl** and making selections.

3. Click the Arm for Record button (Ⓜ) on the event's track. When recording into multiple selected events, arm their respective tracks at this time.
4. Click the Record button (Ⓜ) on the transport bar to begin recording.
5. Click the Record button (Ⓜ) again or the Stop button (■) on the transport bar to stop recording.

Recording into an event with a time selection

Recording into a time selection allows for a pre- and post-roll during recording. The time selection is adjustable to increase or decrease the pre- and post-roll duration. During recording, the selected event's edges serve as the punch-in and -out points. You can create multiple punch-in and -out points by selecting more events within the time selection.

You may need to split an existing event into three pieces so that you can select a smaller portion of the event to record into. *For more information, see [Splitting events](#) on page 69.*

1. Click the Arm for Record button (Ⓜ) on the desired track(s).
2. Select the event to record into.

Tip: You may record into multiple events by pressing **Ctrl** and making your selections.

3. On the marker bar, drag a time selection. You may adjust the time selection by dragging the selection bar's starting and ending points. Make the time selection start before the event for a pre-roll.
4. Click the Record button (Ⓜ) on the transport bar to begin recording.

If input monitoring is turned on, the track's original audio is played until the cursor reaches the selected event. When the cursor plays through the selected event, you'll hear your recording input, and the track's original audio is played again when the cursor moves past the selected event.

Using pre-roll

The previous technique allows you to define the playback region with a time selection and sets the punch-in and punch-out points in the recording to the event boundaries. When you click the Record button, playback begins at the beginning of the time selection. The event is then filled with the newly recorded material. The audio file that is recorded to your hard disk is the full duration of the time selection. The event only contains a portion of the full recorded performance and can therefore be trimmed (both shorter and longer) and repositioned within the event.

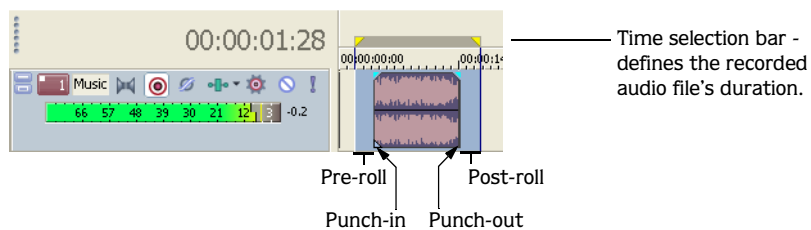

Triggering from MIDI timecode

Recording can be triggered and synchronized by an external MIDI device that outputs (generates) MIDI timecode (MTC). When triggering from MIDI timecode, you should have your audio devices connected together via a master digital word clock. The word clock keeps the audio hardware locked together, eliminating the need for the software to constantly vary its playback rate to stay synchronized. The incoming timecode is only used for an absolute time reference. *For more information, see [Sync tab on page 301](#).*

1. From the **Options** menu, choose **Preferences** and go to the **Sync** tab.
2. From the Trigger from MIDI Timecode settings drop-down list, select the device that you want to trigger Vegas software.
3. Click OK. The Preferences dialog closes.
4. Click the Arm for Record button () on the desired track(s).
5. Right-click the time display and choose **MIDI Timecode In**. The time display now shows the timecode being generated from your MIDI device. The top of the display reads MTC Input Waiting.
6. Begin generating MTC from your MIDI device. The top of the time display now reads MTC Input Locked, the time updates from the MIDI device, and recording automatically begins. Typically, there is a short delay between when you begin generating MTC and synchronization.

Working with multiple recorded takes

Clicking the Loop Playback button () on the transport bar enables you to continually create takes during recording. Takes are different versions of a recorded event that you can quickly switch between to choose the best one. Each take within an event references a different source media file.

During recording with loop playback enabled, the time selection continually repeats and starts recording a new take until you stop recording. You can preview, select, rename, and delete takes. *For more information, see [Working with takes on page 94](#).*

Specifying where recordings are stored

When you record, the event appears on the timeline while its media source file is written to your hard drive. The first time you arm a track to record in a project, you are prompted to identify the location where the recordings will be stored.

Changing where recorded files are stored when arming a track

1. Press **Shift** and click the Arm for Record button () on a track. The Project Recorded Files Folder dialog appears.
2. Browse for the location where you want to save recorded files.
3. Click OK.

Changing where recorded files are stored when starting to record

1. Press **[Shift]** and click the Record button () on the transport bar. The Project Recorded Files Folder dialog appears.

Tip: You can also press **[Ctrl] + [Shift] + [R]** to specify the location for recorded files when starting to record.

2. Browse for the location where you want to save recorded files.
3. Click OK.

Changing where recorded files are stored in the Project Properties dialog

1. From the **File** menu, choose **Properties**. The Project Properties dialog appears.
2. Click the Audio tab to display the project's audio properties.
3. Click Browse. The Recorded Files Folder dialog appears.
4. Browse for the location where you want to save recorded files.
5. Click OK.

Tip: You can select Start all new projects with these settings in the Project Properties dialog to store recorded media source files to the same location in every new project.

Monitoring audio levels

While you're recording, a responsive meter is provided in the track header to monitor the incoming signal level of the selected recording device. It is important that you record with the highest signal possible without clipping.

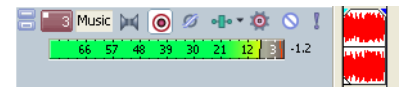



A reading of 0 dB is the maximum for a digital signal. Clipping occurs when the incoming signal is too high to be represented as a digital value. The result is distortion in the recording. A clipped signal will be indicated by a red Clip warning at the top of the meters.

Right-click the meters and choose a command from the shortcut menu to adjust the display of the meters.

Using record input monitoring

If you want to hear your recording signal with real-time track effects, you can turn on input monitoring.

 *Input monitoring is only available in the full version of Vegas software.*

To turn on input monitoring, click the Record Device Selector button ( or **[1]**) and choose **Input Monitor** from the menu, and then choose **Auto** or **On** from the submenu. During recording, your signal will be played back with the current track effects chain, but a dry (unprocessed) signal is recorded.

When **Auto** is selected, you will hear the input monitor signal when playback is stopped and during recording. If you're recording into selected events, you'll hear the input monitor signal only when the cursor passes over the selected events.

When **On** is selected, the behavior is similar to **Auto** mode, but you will always hear the input monitor during recording—monitoring is not toggled on and off when recording in to a selected event.

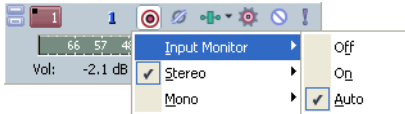

Note: *Your ability to monitor effects in real time is dependent on your computer's performance. Effect automation envelopes are bypassed during record monitoring.*

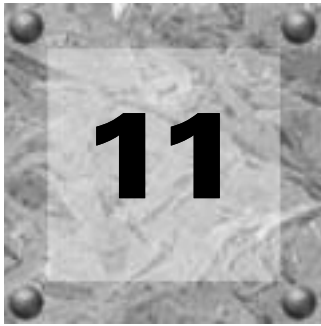

Working with 5.1 Surround

Vegas® software allows you to create 5.1-channel mixes to prepare audio for DVD-Video.



5.1-channel mixing is only available in the full version of Vegas software.

Note: Vegas software plays and mixes uncompressed 5.1-channel audio. Authoring software such as the Sony Pictures Digital 5.1 Surround Plug-In Pack is required to encode 5.1-channel audio to AC-3 for use in DVD authoring.

What is 5.1 surround?

5.1 surround is a standard format consisting of three speakers across the front and two speakers in the rear. The “.1” is a sixth channel called low-frequency effects (LFE) that enhances the bass levels in the mix.

5.1 surround includes five main channels...

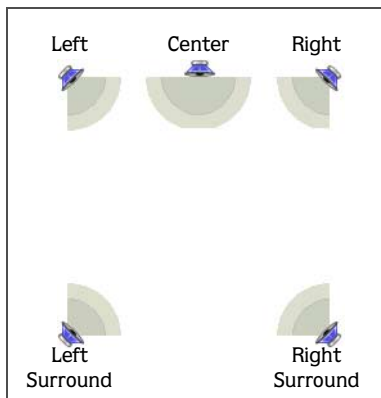

...and a sixth channel for low-frequency effects.

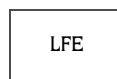

The LFE channel is commonly used in motion pictures to enhance low audio frequencies for effects such as explosions or crashes. Audio in this channel is commonly limited to a range from about 25 Hz to 120 Hz. Unlike the five primary channels, the LFE channel adds no directional information. Depending on the speaker setup and audio levels, the sound assigned to the LFE channel may be routed among the five main speakers or to an additional subwoofer.

Setting up surround hardware

Before you create surround projects, you should set up your system to provide 5.1 surround playback. To play a 5.1 surround project, you must have an appropriate speaker setup such as:

- Six powered speakers
- Six passive speakers with a six-channel amplifier

Your system must also have an appropriate sound card setup such as:

- 5.1-compatible sound card
- Sound card with three stereo outputs
- Three stereo sound cards

There are several ways to set up your system, depending on the sound card and speaker setup you are using.

	Six powered speakers	Six passive speakers with a six-channel amplifier
5.1-compatible sound card	Connect powered speakers to your sound card's outputs as indicated by your sound card's documentation.	Connect your sound card's front, rear, and center/subwoofer outputs to the appropriate inputs on a six-channel amplifier/home theater receiver. Connect front, rear, center, and LFE speakers to the amplifier.
Sound card with three stereo outputs	Connect powered speakers to your sound card's outputs where you have routed each of the pairs of channels. The left channel of the Center/LFE pair is the center channel; the right channel is the LFE channel.	Connect your sound card's outputs to the appropriate inputs on a six-channel amplifier/home theater receiver. Connect front, rear, center, and LFE speakers to the amplifier.
Three stereo sound cards	Connect powered speakers to your sound cards' outputs where you have routed each of the pairs of channels. The left channel of the Center/LFE pair is the center channel; the right channel is the LFE channel.	Connect your sound card's outputs to the appropriate inputs on a six-channel amplifier/home theater receiver. Connect front, rear, center, and LFE speakers to the amplifier.

Setting up surround projects

You can configure a Vegas project to use 5.1 surround in the Project Properties dialog. You can also choose to apply a low-pass filter for the LFE channel. Applying a low-pass filter approximates the bass-management system in a 5.1 decoder and ensures that you're sending only low-frequency audio to the LFE channel.

1. From the **File** menu, choose **Properties**.
2. Click the Audio tab.
3. From the Master bus mode drop-down list, choose **5.1 surround**.
4. To limit the audio sent to the LFE channel, do the following:
 - Select the Enable low-pass filter on LFE check box and enter a value in the Cutoff frequency for low-pass filter box. The low-pass filter isolates the audio sent to the LFE channel by limiting it to frequencies lower than the value entered in the Cutoff frequency for low-pass filter box.
 - Choose a setting from the Low-pass filter quality drop-down list to determine the sharpness of the filter's rolloff curve. **Best** produces the sharpest curve.

Note: Before rendering your surround project, check your surround authoring application's documentation to determine its required audio format. Some encoders require a specific cutoff frequency and rolloff, while other encoders require that no filter be applied before encoding.

5. Click OK.

The track list and Mixer window switch to 5.1 surround mode. The Master bus becomes the Surround Master bus, which contains faders for each of the six surround channels. Surround panners appear on tracks and mixer controls. Tracks routed to mixer controls (busses or assignable effects) do not have surround panners; panning for these tracks takes place on the mixer control.

Track list in 5.1 surround mode

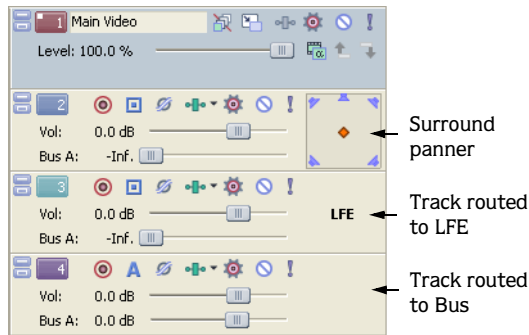

Mixer in 5.1 surround mode

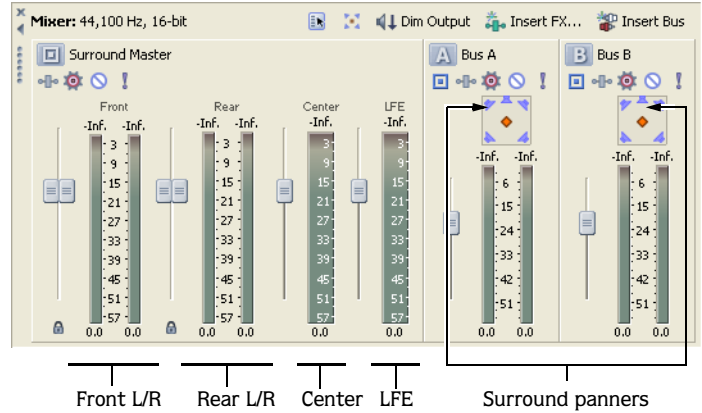

Routing to hardware in the mixer

You must route the surround audio to the correct output in the mixer.

1. From the **Options** menu, choose **Preferences**.
2. Click the **Audio** tab.
3. From the Audio device type drop-down list, choose an audio device type other than **Microsoft Sound Mapper** (such as **Windows Classic Wave Driver**).
4. Choose the playback devices for the six surround channels:
 - From the Default Stereo and Front playback device drop-down list, choose the appropriate device for the front left and right surround channels.
 - From the Default Rear playback device drop-down list, choose the appropriate device for the rear left and right surround channels.
 - From the Default Center and LFE playback device drop-down list, choose the appropriate device for the center and LFE surround channels.
5. Click **OK**.

Overriding the default device routing

By setting up the device routing in the Audio tab of the Preferences dialog, you have set the defaults for surround routing. However, you can override the default device routing at any time using the Surround Master bus in the Mixer window.

1. In the Mixer window, click the Audio Device Selector button () on the Surround Master bus. A menu of surround channels (**Front L/R**, **Rear L/R**, and **Center/LFE**) appears.
2. In the submenu, match a surround pair with the appropriate output.
3. Repeat steps one and two to match each surround pair to the appropriate output.

Assigning audio to the LFE channel

Once the project is in 5.1 surround mode, you must decide whether a track will provide the “5” (surround panning) or the “1” (LFE channel) in 5.1 surround. Initially, all tracks in a surround project are set to provide surround panning, but you can assign a track to the LFE channel instead.

You can assign an individual track to the LFE channel or you can route the track to a mixer control (bus or assignable effect chain) and assign the mixer control to the LFE channel.

To assign audio to the LFE channel, right-click the surround panner on the track header or mixer control and choose **LFE Only** from the shortcut menu. The track or mixer control is assigned to the LFE channel.

Right-click the surround panner and choose LFE Only...

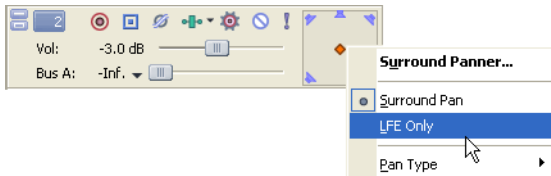

...to assign the track or mixer control to the LFE channel.

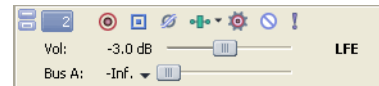

To change a track or mixer control back to surround panning, right-click the LFE indicator and choose **Surround Pan** from the shortcut menu.

Note: Before rendering your surround project, check your surround authoring application's documentation to determine its required audio format with respect to the LFE channel. For more information, see [Setting up surround projects](#) on page 174.

Adjusting volume

Adjusting track volume for 5.1 surround projects behaves almost identically to stereo projects. The controls in the track headers and Mixer window can function as trim controls that adjust the overall volume of the track, bus, or assignable effects chain, or they can adjust volume automation settings. For more information, see [Track automation](#) on page 119.

Adjusting track volume

You can adjust track volume using the Vol fader in the track header the same way you do in stereo projects.

Click the **Automation Settings** button (⚙️) on the track header and verify **Show Automation Controls** is not selected if you want to adjust trim levels.

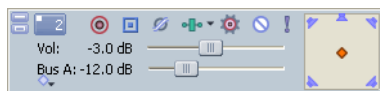

Track header in trim mode

Select **Show Automation Controls** if you want to adjust volume automation. The fader handle is displayed as a 📏 in automation mode.

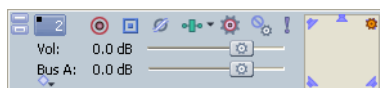

Track header in automation mode

Adjusting assignable effects send or bus send levels

You can adjust send levels for busses or assignable effects chains using the multipurpose fader in the track header. Click the fader label and choose an assignable effects chain or bus from the menu. The fader in the track header can function as a trim control that adjusts the overall send level of the track, or it can adjust send level automation settings.

Click the Automation Settings button (⚙️) on the track header and verify **Show Automation Controls** is not selected if you want to adjust trim levels.

Select **Show Automation Controls** if you want to adjust volume automation. The fader handle is displayed as  in automation mode.

Adjusting channel levels

Use the Surround Master bus control in the Mixer window to adjust the individual levels of the 5.1 channels. The faders in the track bus control can function as trim controls that adjust the overall level of each channel, or you can automate the master volume of the Surround Master bus (individual channel levels cannot be automated).

Click the Automation Settings button (⚙️) in the bus control or bus track and verify **Show Automation Controls** is not selected if you want to adjust trim levels.

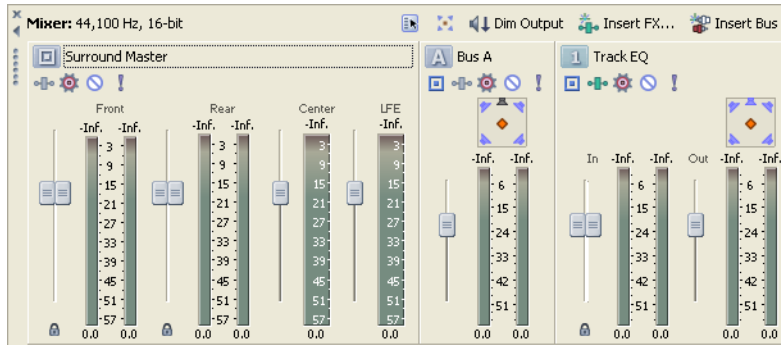

Mixer controls in trim mode

Select **Show Automation Controls** if you want to adjust volume automation. The fader handle is displayed as  in automation mode.

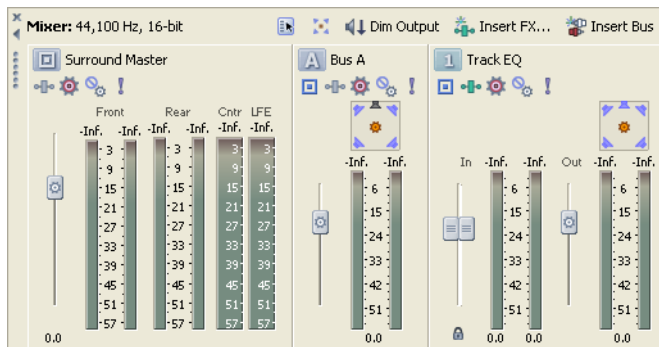

Mixer controls in automation mode

Panning audio

You can pan audio in a 5.1 surround project in two ways:

- Pan tracks individually using the Surround Panner window.
- Route tracks to mixer controls (busses, assignable effect chains) and pan the mixer controls using the Surround Panner window.

Panning tracks

1. Click the Automation Settings button (⚙️) on the track you want to pan and verify Show Automation Controls is not selected.
2. Double-click the surround panner on the track you wish to pan. The Surround Panner window appears.

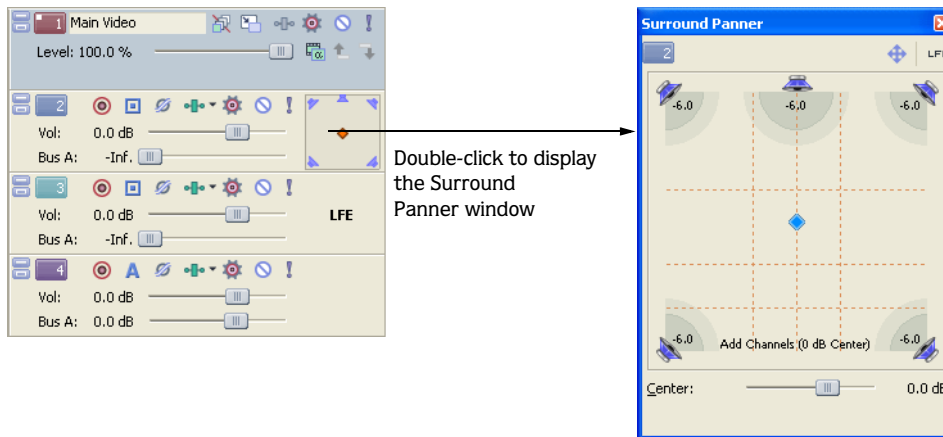

3. Adjust the panning settings. *For more information, see [Using the Surround Panner window](#) on page 180.*
4. Close the Surround Panner window.

Tip: You can also use the surround panner in the track header to pan your track.

Panning mixer controls

You may choose to route tracks to busses or other mixer controls (such as assignable effect chains) and pan them as a group rather than panning each track individually.

Note: When you route a track to a bus, stereo (two-channel) output is sent to the mixer control and the mixer control sends 5.1 (six-channel) output to the Surround Master bus.

1. Add a bus or assignable effect chain to the project. For more information, see [Using the Mixer on page 143](#).
2. Route tracks to the bus or assignable effect chain. For more information, see [Using the Mixer on page 143](#).
3. Click the Automation Settings button (⚙️) on the mixer control you want to pan and verify Show Automation Controls is not selected.
4. Double-click the surround panner on the mixer control to display the Surround Panner window.

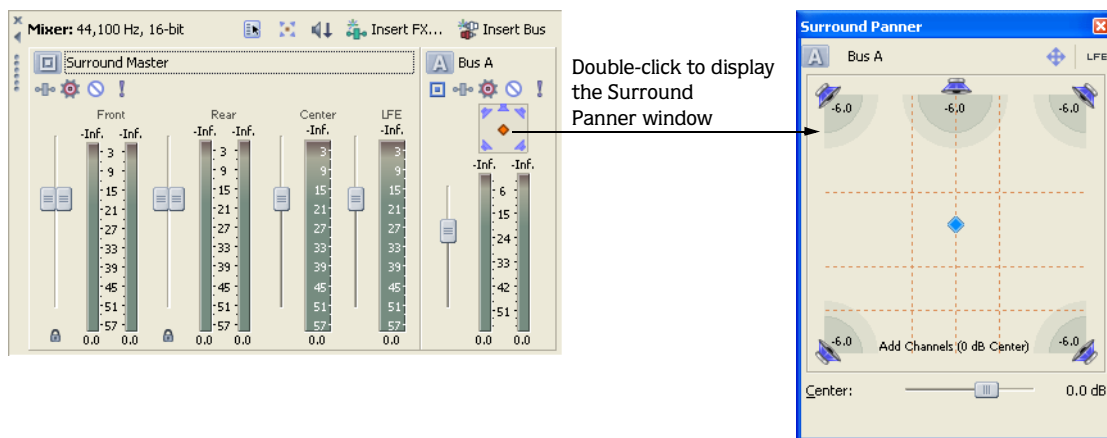

5. Adjust the panning settings. For more information, see [Using the Surround Panner window on page 180](#).
6. Close the Surround Panner window.

Tip: You can also use the surround panner on the mixer control to pan your track.

Using the Surround Panner window

Whether you're adjusting track panning or mixer control panning, you use the same controls in the Surround Panner window.

View the Surround Panner window by double-clicking a surround panner on a track header or mixer control. Once the Surround Panner window is open, you can dock it in the workspace. *For more information, see [Window docking area and floating window docks on page 21](#).*

Tip: You can also choose Surround Panner from the **View** menu to display the Surround Panner window. Once the Surround Panner window is displayed, double-click the surround panner for a track or mixer control to view its pan settings.

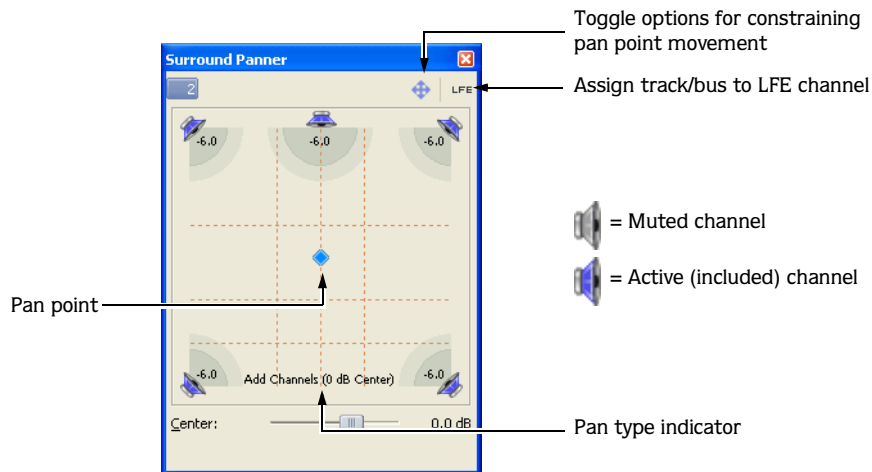

1. Click the speaker icons to mute or include channels.

Muting a channel ensures that no audio bleeds through a channel. For example, you might want to mute all but the center channel when you're panning dialogue to the center channel.

Tip: **Ctrl** + click a speaker icon to solo the channel.

2. Drag the pan point to position the sound within the sound field. *For more information, see [Moving the pan point on page 181](#).*
3. Click the center speaker icon to include the center channel and drag the Center fader to apply a gain to the center channel.





Applying a gain to the center channel may make dialogue more present in the mix.

Note: When automating panning using keyframes, you cannot automate the gain applied using the Center fader. For more information, see [Automating panning on page 182](#).

4. Drag the Smoothness slider to adjust the smoothness of the interpolation path between panning keyframes. The smoothness setting appears only when you are automating panning using keyframes. *For more information, see [Adjusting the Smoothness slider on page 184](#).*

Moving the pan point

A variety of methods are provided to help you position the pan point in the Surround Panner window.

Method	Description
	Click to toggle through three options for constraining pan point motion as you drag: Move Freely () , Move Left/Right Only () , and Move Front/Back Only () .
Double-click	Double-clicking the pan point resets it to the center front of the surround panner. Double-clicking in the Surround Panner window moves the pan point to the double-click location.
Ctrl+drag	Makes fine adjustments.
Shift+drag	Constrain motion to a line through the center of the surround panner
Alt+drag	Constrains motion to a constant radius from the center of the surround panner.
Shift+Alt+drag	Constrains motion to the maximally inscribed circle (a constant radius at the greatest possible distance from the center of the surround panner).
Arrow keys	Moves front/back/left/right.
Ctrl+Arrow keys	Makes fine adjustments.
Page Up/Page Down	Moves front/back.
Shift+Page Up/Page Down	Moves left/right.
Numeric keypad 1-9	Jumps to a corner, edge, or center of the surround panner.
Ctrl+Numeric keypad 1,3,7, 9	Jumps to a location on the maximally inscribed circle (a constant radius at the greatest possible distance from the center of the surround panner).
Mouse wheel	Moves front/back.
Shift+mouse wheel	Moves left/right.
Ctrl+mouse wheel	Makes fine front/back adjustments.
Ctrl+Shift+mouse wheel	Makes fine left/right adjustments.

Choosing pan types

When you pan a track or mixer control, you can choose among several pan types to determine how to pan the audio. The current pan type appears at the bottom of the Surround Panner window.

Right-click the Surround Panner window and choose a pan type from the shortcut menu.

- The **Add Channels** pan type makes the audio appear to move as a unit among the surround channels. As you move the pan point toward a channel (speaker icon), more and more of the signal from the other channels are folded into the channel you are panning towards, until at the extreme, all channels are fed at full intensity into a single channel. This pan type uses a linear panning curve.
- The **Balance** pan type is most useful for adjusting the relative signal levels of the channels. In this pan type, as you move the pan point from the center to a channel, the signal in the channel you are panning towards starts at the base dB level (either 0 dB, -3 dB, or -6 dB) and increases to 0 dB. The signal in the channel you are panning away from starts at a base dB level (either 0 dB, -3 dB, or -6 dB) and decays to no signal level. For example, when you pan fully to the right, only the right channel is audible. This pan type uses a linear panning curve.
- The **Constant Power** pan type maintains a constant volume as you move the pan point from channel to channel. This pan type, which uses the constant-power panning curve, is most useful for panning monaural source media.
- The **Film** pan type allows you to pan between pairs of speakers using a constant-power panning curve. As you drag the pan point to the center speaker, the sound becomes diffused through the front and rear speakers. When the track is panned fully to the center speaker, there is no sound from the front and rear speakers.

Using the grid to monitor panning

The grid in the Surround Panner window helps you to visualize how your panning will sound. The grid's spacing changes to match the current pan type.

The vertical lines represent the points where the left-to-right signal ratio is 6 dB, 0 dB, and -6 dB respectively: at the far-left line, the left channel is 6.0 dB louder than the right channel.

The horizontal lines represent the points where the front-to-rear signal ratio is 6 dB, 0 dB, and -6 dB respectively. As you adjust the Center fader, the lines move forward or backward to compensate for the center-channel gain.

Note: *The grid assumes that you're using a correctly set-up surround system (matched speakers and ideal positioning). Variations in your monitoring system will cause inconsistencies between the graph and perceived output.*

Automating panning

You can automate panning on a track or mixer control by adding keyframes. Keyframes are similar to envelope points in that they specify a settings state at a point in time. However, unlike envelope points, keyframes appear just below the track to which they apply.

To add panning keyframes to a mixer control, you must first view the mixer control in track view. From the **View** menu, choose **Show Bus Tracks** to view the bus track at the bottom of the track view. *For more information, see [Viewing bus tracks](#) on page 152.*

Turning on panning keyframes

Before adding individual keyframes, you must first turn on the panning keyframes for the track or bus track.

1. Select the track or bus track for which you want to automate panning.
2. From the **Insert** menu, choose **Audio Envelopes**, and choose **Surround Pan Keyframes** from the submenu.

An additional row appears below the track with a single keyframe positioned at the beginning of the project. This single keyframe represents the current panning settings for the track.



Adding panning keyframes

With panning keyframes turned on, you can add keyframes at any location along the track or bus track.

1. Position the cursor where you want to begin panning the track.
2. Click the Automation Settings button (⚙️) on the track you want to pan and select **Show Automation Controls**.
3. Double-click the surround panner to display the Surround Panner window.
4. Adjust the panning settings. *For more information, see [Using the Surround Panner window](#) on page 180.*

Note: *You cannot automate muting/including channels.*

5. Close the Surround Panner window.

A keyframe with the pan settings you created appears below the track at the cursor position.



Tip: You can also add keyframes by double-clicking the keyframe row or by right-clicking the row and choosing **Add Point** from the shortcut menu. Once you've added the keyframe, double-click it to adjust panning settings in the Surround Panner window.

As you add keyframes to a track or bus track, the Surround Panner window shows the path of the panning keyframes. The Smoothness slider controls the smoothness of the interpolation path between the keyframes. For more information, see [Adjusting the Smoothness slider](#) on page 184.

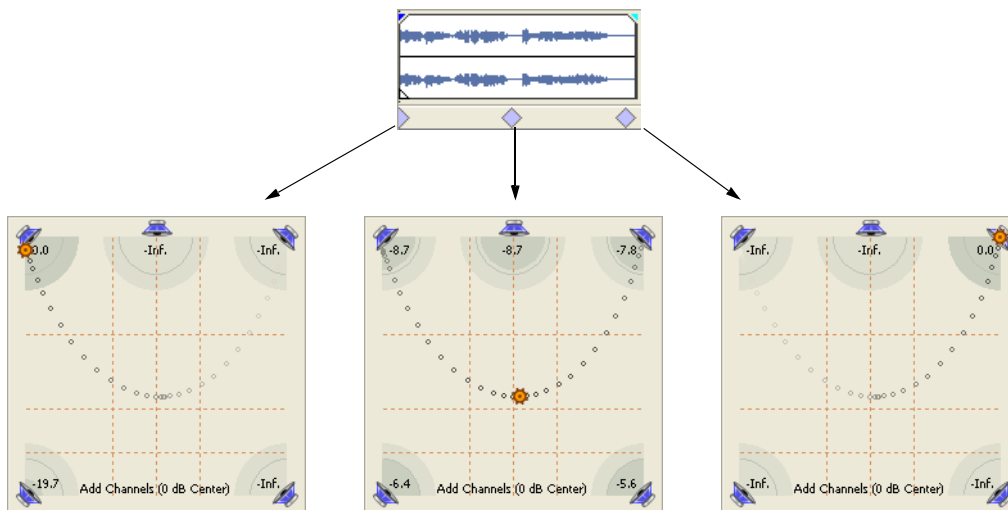

The Surround Panner window shows the path of the panning keyframes.

Working with keyframes

After you add keyframes, you can work with them in much the same way as envelope points. For more information, see [Composite level automation \(video only\)](#) on page 124.

Moving keyframes

Drag a keyframe to a new position below its track.

Duplicating keyframes





Hold **Ctrl** and drag a keyframe to a new position below its track.

Editing keyframes

1. Double-click a keyframe to open the Surround Panner window.
2. Adjust the panning settings as desired and close the window.

Changing keyframe interpolation curves

To control how the pan is interpolated between keyframes, right-click a keyframe and choose an interpolation curve type from the shortcut menu. Keyframe interpolation curves control how the pan occurs over time. The keyframe color changes according to the interpolation curve you have chosen.

Keyframe	Interpolation curve	Description
	Hold	No interpolation takes place. The keyframe's settings are maintained until the next keyframe.
	Linear	Panning is interpolated in a linear path.
	Fast	Panning is interpolated in a fast logarithmic path.
	Slow	Panning is interpolated in a slow logarithmic path.
	Smooth	Panning is interpolated along a smooth, natural curve.

Adjusting the Smoothness slider

The Smoothness slider controls the perceived motion of sound within the sound field among three or more keyframes. When you drag the Smoothness slider to 0, Vegas software interpolates the changes between keyframes along a linear path. As you increase the smoothness value, the path between keyframes grows more curved and smooth.

1. Double-click a keyframe. The Surround Panner window appears.

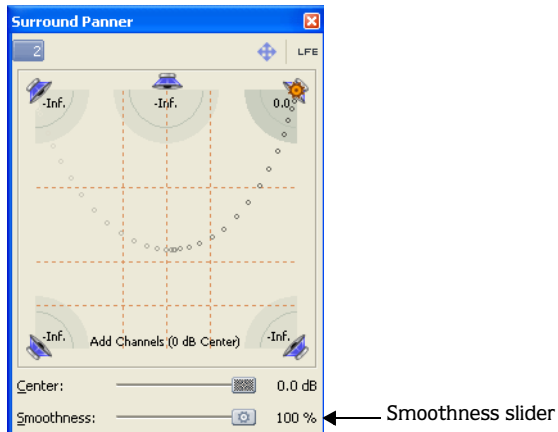

2. Drag the Smoothness slider to adjust the smoothness of the spatial interpolation path leading up to this keyframe.

Three keyframes with smoothness=100...

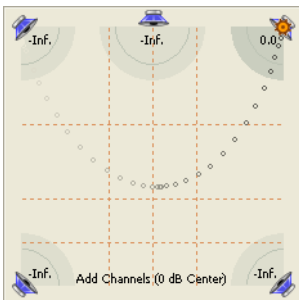

...and the same three keyframes with smoothness=0.

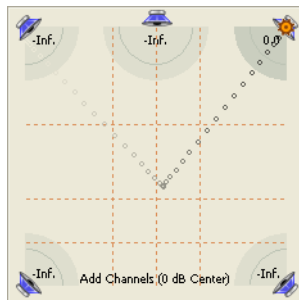

Locking keyframes to events

If you want keyframes to move with an event when it is moved along the timeline, choose **Lock Envelopes to Events** from the **Options** menu.

Hiding keyframes

1. Select the track for which you want to hide keyframes.
2. From the **View** menu, choose **Show Audio Envelopes**, and choose **Surround Pan Keyframes** from the submenu.

Deleting keyframes

Right-click a keyframe and choose **Delete** from the shortcut menu.

Rendering surround projects

5.1 surround projects are rendered to produce six monaural files (AIFF, WAV, W64, or PCA) or a single 5.1-channel file (AC-3, WMA, and WMV). You can then use an authoring application to create the final DVD-Video or 5.1-channel music project from the rendered files.

Note: Before rendering your surround project, check your surround authoring application's documentation to determine its required audio format with respect to the LFE channel. For more information, see [Setting up surround projects](#) on page 174.

1. From the **File** menu, choose **Render As**. The Render As dialog appears.
2. From the Save in drop-down list, choose the drive and folder where the file will be saved.
3. Enter a new name for the project in the File name box.
4. From the Save as type drop-down list, choose the desired file format.
5. Choose **44,100 Hz, 16 Bit, Mono, PCM** from the Template drop-down list if you want to render six monaural files, or choose an appropriate 5.1-channel template if the selected file type supports it.
6. If necessary, click Custom to customize the rendering settings. For more information, see [Customizing the rendering process](#) on page 275.
7. Select the Render loop region only check box if you want to save only the portion of the project that is contained within the loop region. Loop Playback does not need to be selected on the workspace for this option to work.
8. If the selected file type supports it, you can select the Save project markers with media file check box to include markers, regions, and command markers in the rendered media file. If the information cannot save in your media file, it will create an .sfl file (using the same base name as your media file).

9. Click Save.

Rendering the surround project SampleProject.wav...

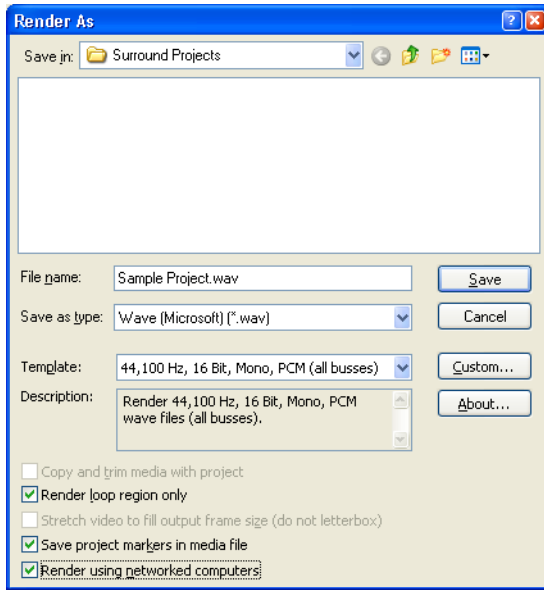

...results in six WAV files.

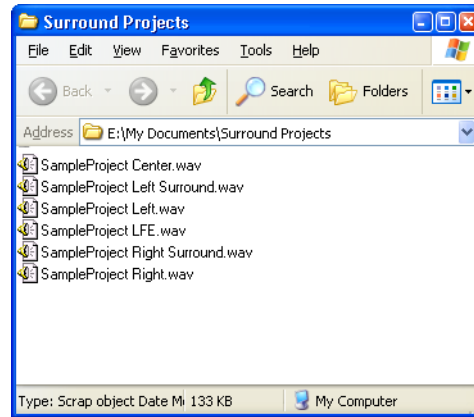

Note: You can use an application such as the Sony Pictures Digital 5.1 Surround Plug-In Pack to encode 5.1-channel audio to AC-3 for use in DVD authoring.

Creating a DVD with DVD Architect Software

If you have DVD Architect™ software from Sony Pictures Digital, you can create menu-based DVDs, music compilations, picture compilations, or a single-movie DVD that will play back automatically in your DVD player.

DVD Architect software includes support for many file types and can convert your media to the formats required for DVD as needed. However, for best performance (decreased disc preparation time and recompression), render your files in the appropriate format.

MPEG-2 video files rendered with the DVD NTSC or DVD PAL templates will not need to be recompressed. Audio will not need to be recompressed if rendered as stereo or surround AC-3 files with a bitrate of less than 448 kbps or as stereo, 48-kHz, 16-bit, WAV (PCM) files.

Note: AC-3 audio may not play back on some PAL DVD players. To ensure compatibility with PAL DVD players, use 48-kHz, 16-bit, WAV (PCM) files for audio.



Using Advanced Video Features

While simple to learn, Vegas® software is a powerful application with many advanced features. This chapter covers some of the advanced video features of this powerful tool.

Cropping video

With the Event/Pan Crop window, you can resize media in a video event or selectively crop media without resizing. The Stretch to fill frame drop-down list allows you to resize the media to fill the output frame (when Yes is selected), or to crop out a portion of the media without resizing (when No is selected).

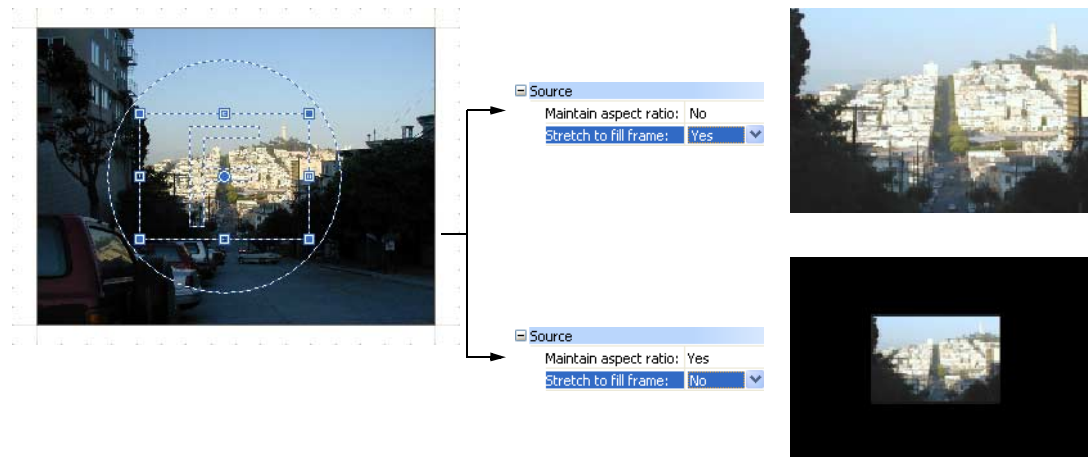

When keyframes are added, you can use this window to create scrolling, panning, or zooming effects. For more information, see [Using keyframe animation](#) on page 237.

Tip: If you apply plug-ins to a event with panning or cropping, you can choose whether to process the plug-ins before or after the panning or cropping. For more information, see [Processing plug-ins on events with panning or cropping](#) on page 209.

Open the Event Pan/Crop window by clicking the Event Pan/Crop button () on the event.

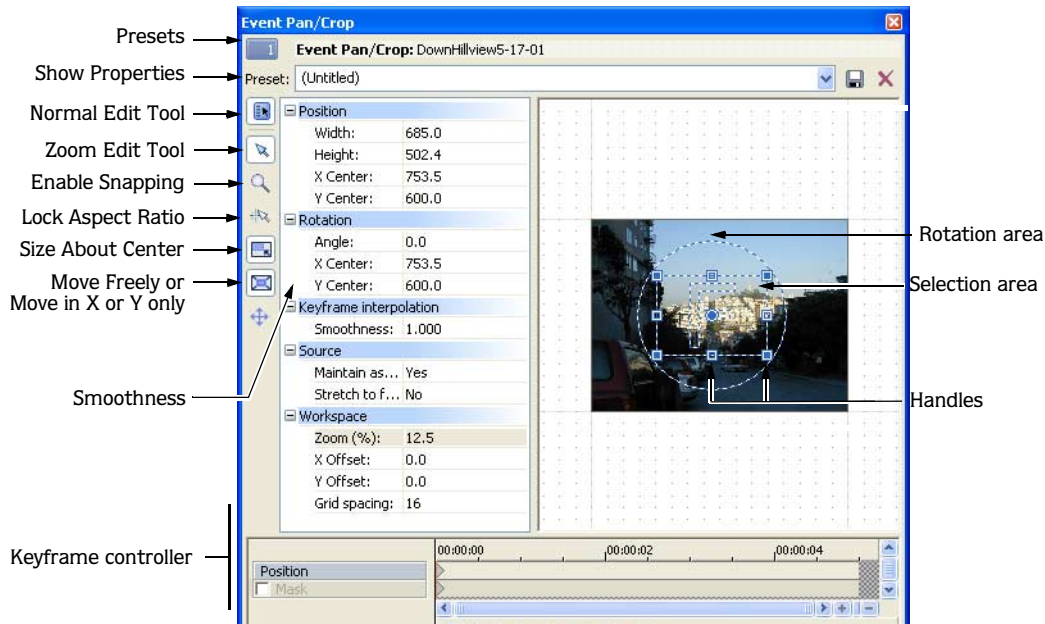



Note: If any controls shown in the figure above are not visible, enlarge the Event Pan/Crop window by dragging the lower right corner until all controls are revealed.

The Smoothness control and the keyframe controller are used when adding keyframe animation to create panning, zooming, or scrolling effects. For more information, see [Animating event panning and cropping](#) on page 241.

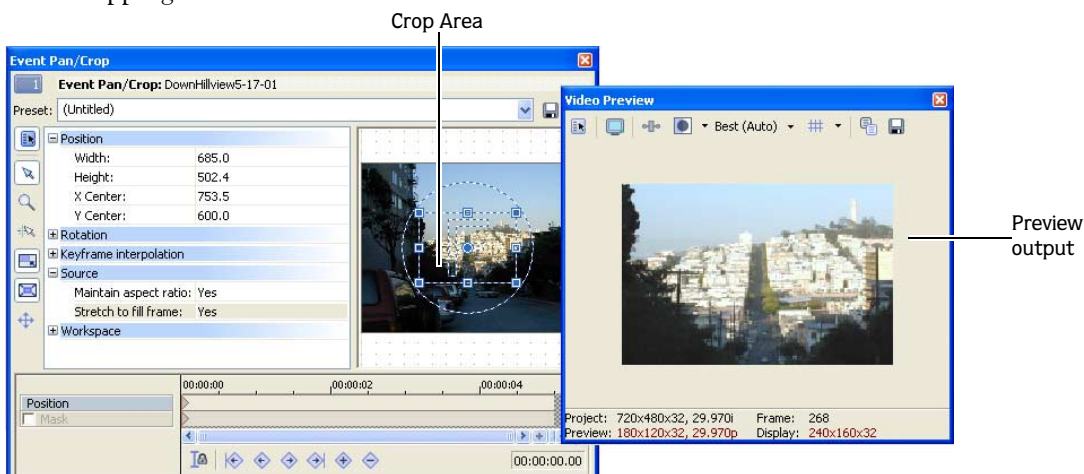

Cropping

Cropping is the process of removing the outside edges from an image or video, thereby re-framing the subject. In the following example, the Event Pan/Crop window on the left has been used to create a selection area around the subject, removing extraneous information from the outside of the video. This creates a zoom effect that is similar to zooming in with a camcorder. The Video Preview window on the right displays the event after cropping.



1. Click the Event Pan/Crop button () on the event.
2. Drag the handles (small boxes) located around the perimeter of the selection area to change the size.
3. Move the mouse to middle of the selection area until the cursor changes to a move icon (). Drag the selection area to reposition it.

Be aware of the following as you crop a video event:

- To keep the selection area centered as you resize, select the Size About Center button ().
- To maintain the proportion of the selection area, select the Lock Aspect Ratio button ().
- To prevent distortion of the source media file, ensure that Maintain aspect ratio is set to **Yes**.
- To restore the selection area to full frame, right-click the image and choose **Restore** from the shortcut menu.
- To set the selection area to a standard aspect ratio proportion, choose a preset from the Preset drop-down list.
- When using photographs or other media that is not the same frame aspect as your video, you'll see black bars on the sides or above and below the image. To create a crop rectangle that matches the project frame aspect, right-click the image and choose **Match Output Aspect** from the shortcut menu.



The cropping occurs instantly and the results are updated in the Video Preview window. Cropping applies to the entire event and can be animated with keyframes. *For more information, see [Using keyframe animation](#) on page 237.*

Bézier masks

You can use the Event Pan/Crop dialog to create masks using Bézier curves. *For more information, see [Bézier masks \[Bezier\]](#) on page 223.*

Rotating

You can also rotate the selection area in the Event Pan/Crop window. If you rotate the entire frame, the background behind the video shows through. Position, size, and rotation can all be animated with keyframes. *For more information, see [Using keyframe animation](#) on page 237.*

1. Click the Event Pan/Crop button () on the event.
2. Resize and move the selection area as desired. *For more information, see [Cropping](#) on page 188.*
3. Move the mouse outside the selection area until it becomes a rotate icon (). Drag to rotate the selection area. Alternately, you may enter precise rotation values in the Angle (degrees) box.

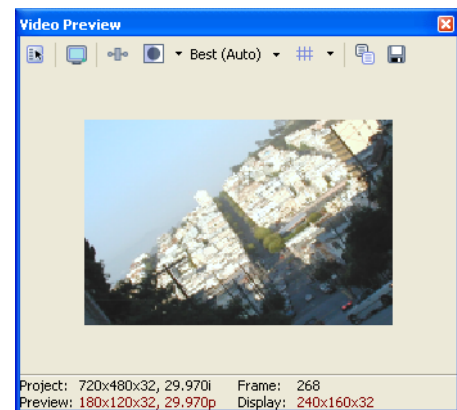

Adding animation

Keyframe animation dramatically increases the variety of panning, zooming, and rotating effects you can create using the Event Pan/Crop window. A later chapter provides examples of zooming in on a still image and using pan-and-scan techniques. *For more information, see [Animating event panning and cropping](#) on page 241.*

Working with still images

You can use still images for a number of purposes including slide shows, overlay graphics, and titles. You can insert still images into projects just like any other media files. The default length for a still image event when it is first added to a track is five seconds (this is an adjustable preference), but this duration can be modified by dragging the edges to create a still image event of any length. Images cannot be looped, but share many characteristics with video files, including transparency. In addition, you can use many of the same tools on image events that you can on video events, such as track motion, panning and cropping, and video effects plug-ins. *For more information, see [Zooming in on a still image](#) on page 241.*

Creating still images for use in Vegas software

Many image formats can be imported: BMP, GIF, JPG, PNG, TIFF (requires QuickTime™), PSD (flattened), and TGA. If you have the option to create PNG files in your graphics software, this is the recommended file type. PNG files use lossless compression and can also include alpha channel information, which is one of the cleanest methods of creating transparency for overlays. An alpha channel can automatically be detected, if present, in PNG files.

Note: *The alpha channel may not be automatically detected in TGA images. Right-click a TGA image in the Media Pool or an event on the timeline and choose **Properties**. Then, in the Media Properties dialog, select the type of alpha channel from the list.*

If you know your media file has an alpha channel and it is not detected properly, right-click the media file in the Media Pool or an event on the timeline and choose **Properties** from the shortcut menu. Then, in the Media tab, select the appropriate alpha channel type from the Alpha channel drop-down list. **Premultiplied** is the recommended setting. You can save this setting so that the alpha channel is properly detected on other media files with the same properties. *For more information, see [Setting custom stream properties](#) on page 203.*

Correcting images for DV pixel aspect ratios

For best results when importing still images, create images that account for the pixel aspect ratio of your desired output format. Vegas software does a good job stretching images to fit the output format, but some distortion occurs if the pixel aspect ratio for the source format does not match the destination format.

To calculate pixel aspect ratio correction, use this formula:

$$\text{Output frame pixel width} \times \text{Output format pixel aspect ratio} = \text{Still image pixel width}$$

For example, this is the formula for NTSC DV format:

$$720 \text{ (DV screen frame pixel width)} \times .9091 \text{ (DV pixel aspect ratio)} = 655 \text{ (pixel width)}$$

Use these figures as a guide when creating images:

- Full frame, pixel-aspect-corrected still images for use in NTSC DV projects are 655x480.
- Full frame, pixel-aspect-corrected still images for use in PAL DV projects are 787x576.

Capturing a timeline snapshot

You can create still images of a single frame of your project. Once saved, the snapshot can be used just like any other still image.

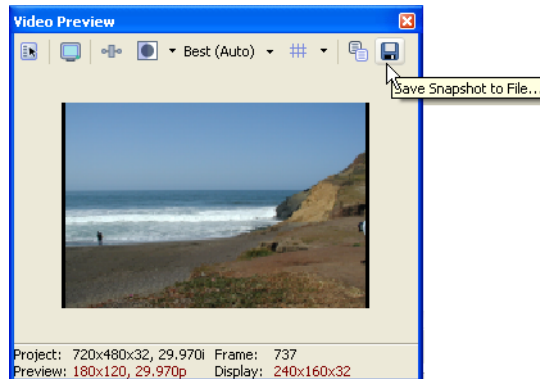

1. Position the cursor on the frame of the project you wish to capture as a still image.
2. Click the Save Snapshot to File button () on the Video Preview window. The Image Filename dialog appears.
3. Select a file format (JPEG or PNG) and enter a name for the new still image file.
4. Click Save. The image is added to the Media Pool.

Creating a slide show

A slide show composed of still images and an accompanying soundtrack can be an excellent way to show off your pictures. You can insert multiple images to instantly create a slide show, complete with crossfades.

Importing high-resolution still images and using panning, cropping, and track motion tools can add interest to an otherwise static slide show. *For more information, see [Cropping video](#) on page 187 and [Adding track motion](#) on page 245.*

1. In the **Options** menu, verify that **Automatic Crossfades** is selected.
2. From the **Options** menu, choose **Preferences**. Adjust the following settings on the Editing tab:
 - Enter the length for the still images in the New still image length box.
 - Select Automatically overlap multiple selected media when added.
 - Enter the length of the automatic overlap in the Amount box in the Cut-to-overlap conversion section of the dialog.
3. Click OK. The Preferences dialog closes.
4. Select all of the images you want to use in the Explorer.
5. Right-click and drag these files to the timeline.
6. From the shortcut menu, choose **Add Across Time**.

If you want, you can replace the crossfades between images by dragging transitions to the crossfade regions at a later time. For more information, see [Using transition effects](#) on page 231.

Note: When using photographs or other media that is not the same frame aspect as your video, you'll see black bars on the sides or above and below the image. To create a crop rectangle that matches the project frame aspect, right-click the image and choose Match Output Aspect from the shortcut menu.

Creating titles

Most video projects include titles and credits. There are two ways to add text to your project. You can use the titling engine (text generator) or you can use an external image-editing program to create titles. For more information, see [Using generated media](#) on page 211.

Creating titles from images

While every software application is slightly different, the general procedure for creating titles with a transparent background is as follows.

1. Start your image-editing application.
2. From the **File** menu, choose **New**. Set the dimensions of the new image to be the same as the frame size for the project. For more information, see [Correcting images for DV pixel aspect ratios](#) on page 190. Make the default canvas (background) color a solid color. The background will be transparent in the final image, so any solid color works.
3. Select the Text tool and enter the text for your title.

Note: Size and position your titles carefully to fit within the Title Safe Area or the titles may extend beyond the edges of your television. For more information, see [Identifying safe areas](#) on page 258.

4. From the **File** menu, choose **Save As**.
5. From the Save as type drop-down list, choose TGA, PNG, PSD or BMP (PNG is recommended). Make sure that you save the alpha channel information (for TGA and PNG), which is used for transparency.
6. Enter a name and click Save.
7. Insert the image in a track just above the one with the video that will be in the background.

8. Click the Compositing Mode button () on the title track and choose **Source Alpha** if your image has an alpha channel associated with it. If it does not, you may need to add a chroma key filter to the image and key out the background. For more information, see [Chroma keying](#) on page 228.

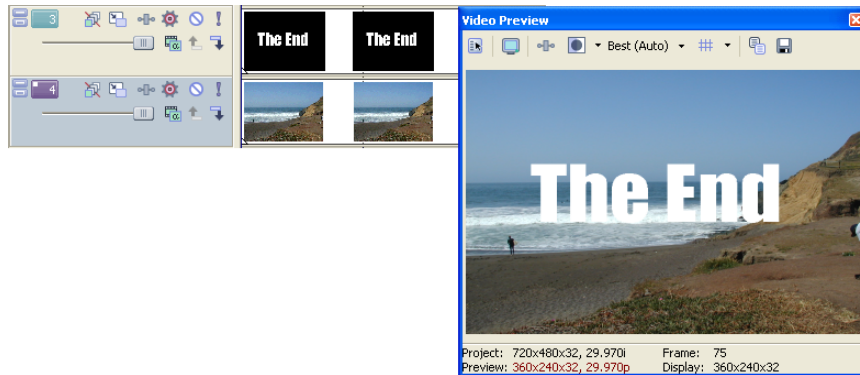

Note: The alpha channel is saved as a selection area in some programs. If you cannot save the alpha channel, use a black background and a mask will be created from the background. The alpha channel of TGA images may not be detected automatically. For more information, see [Modifying media file properties](#) on page 202.

Fading titles

Another common technique is to fade a still title in and out. You can create this effect by using an opacity envelope on a title event. For more information, see [Using opacity envelopes](#) on page 139.

You can also create multiple title images and then use crossfades or custom transitions between them. For more information, see [Using transition effects](#) on page 231.

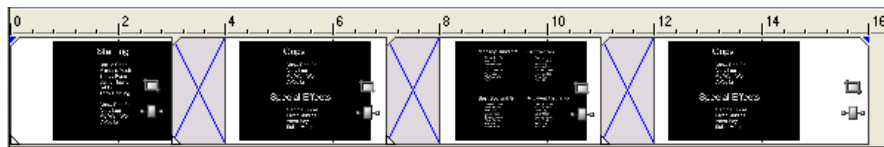

Adding closed captioning to Windows Media Video (WMV) files

Closed captioning makes your final video accessible to a wider audience. You can use text commands to add captions line-by-line to a Windows Media® Video (WMV) file, or for longer projects, you can add captioning from a script.

Adding closed captioning line-by-line

1. Position the cursor where you want the closed captioning text to appear.
2. From the **Insert** menu, choose **Command**. The Command Properties dialog appears.
3. From the Command drop-down list, choose Text.
4. In the Parameter box, enter the closed captioning text you want to display.
5. Click OK.
6. Repeat steps 1-5 for each line of closed captioning text you want to add.
7. Render your file in Windows Media Video format. *For more information, see [Rendering a project on page 271](#).*

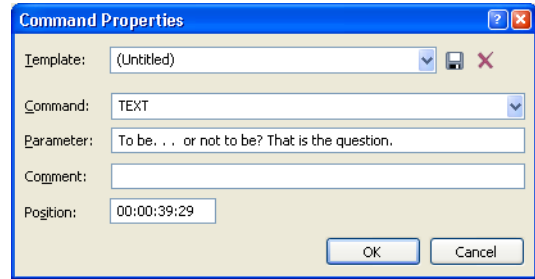

Tip: Take steps to ensure that the closed captioning displays when the video is played. For more information, see [Displaying closed captioning on page 196](#).

Adding closed captioning from a script

Using a script to generate closed captioning involves several steps. First, you must copy and paste the lines from the script into a spreadsheet. You can create the spreadsheet from scratch (using the steps that follow) or use the sample shell (Vegas Captioning Shell.txt) provided in the Samples folder on the Vegas software CD. You can open this tab-delimited shell with a spreadsheet application or, in the absence of a spreadsheet application, any text editor.

Once the spreadsheet is complete, you can copy and paste the lines into the Edit Details window. You can set the position for each line of closed captioning during playback.

Creating a script spreadsheet

1. Create a four-column, tab-delimited spreadsheet.
2. In the first column, enter 00:00:00:00 in each of the cells as a placeholder. You will set the actual position of each line during playback.
3. In the second column, enter TEXT in each of the cells to specify the command type.
4. In the third column, enter the text that you want to display as a closed caption. Enter each line in its own cell.

Tip: *If you have a script, you can copy and paste individual lines into the cells.*

5. In the fourth column, enter a label to identify your captions. An entry such as Line 001 can help you sort the captions once you paste them into your Vegas project.

	A	B	C	D
1	00.00.00.00	TEXT	But, soft! What light through yonder window breaks?	Line 001
2	00.00.00.00	TEXT	It is the east, and Juliet is the sun.	Line 002
3	00.00.00.00	TEXT	Arise, fair sun, and kill the envious moon,	Line 003
4	00.00.00.00	TEXT	Who is already sick and pale with grief,	Line 004
5	00.00.00.00	TEXT	That thou her maid art far more fair than she:	Line 005
6	00.00.00.00	TEXT	Be not her maid, since she is envious;	Line 006
7	00.00.00.00	TEXT	Her vestal livery is but sick and green	Line 007
8	00.00.00.00	TEXT	And none but fools do wear it; cast it off.	Line 008
9	00.00.00.00	TEXT	It is my lady, O, it is my love!	Line 009
10	00.00.00.00	TEXT	O, that she knew she were!	Line 010
11	00.00.00.00	TEXT		Line 011

Note: *The final caption displays in the Microsoft® Windows Media® Player until the end of the video. To clear the final caption sooner, add a final command with no text (as shown above).*

Copying and pasting captions into Vegas software

1. Select the cells in the spreadsheet and copy them.
2. Switch to Vegas software and choose **Edit Details** from the **View** menu. The Edit Details window appears.
3. From the Show drop-down list, choose **Commands**.
4. Right-click the gray box in the upper-left corner and choose **Paste** from the shortcut menu. The spreadsheet data is pasted into the Edit Details window.
5. Click the column header for the Comments column. This sorts the captions by line number.

Right-click to paste the spreadsheet contents into the Edit Details window.

Click the Comments column header to sort the captions by line number.



Setting closed captioning timing

1. Position the cursor shortly before where you want the first caption to occur.
2. Select the row for the first caption in the Edit Details window.
3. Click the Play button (▶) to start playback.
4. When playback reaches the place where the first caption should occur, press **Ctrl** + **K**. The first caption is inserted at the cursor position, updates the Position setting in the Edit Details window, and selects the next caption.
5. Press **Ctrl** + **K** to insert each subsequent caption.
6. Render your file in Windows Media Video format. *For more information, see [Rendering a project](#) on page 271.*

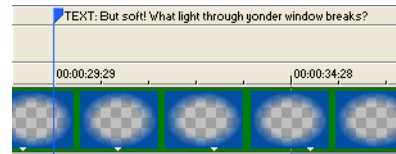

Displaying closed captioning

You may use one of two methods for displaying the closed captioning when the video is played:

- Instruct your audience to turn on captioning. In Windows Media Player 7 and 8, choose **Now Playing Tools** from the **View** menu and choose **Captions** from the submenu.
- Create an HTML page with the Windows Media Player embedded in it. See the online help for a sample HTML page.

Resampling video

Resampling allows Vegas software to interpolate frames in an event when the frame rate of a media file is lower than the project's frame rate. With resampling, the intervening frames are interpolated from the source frames, much like a crossfade between the original frames.

You can instruct Vegas software to resample the video of a single video event or to resample the entire project at the time of final rendering:

- To resample an event, right-click a video event and choose **Properties** from the shortcut menu. In the Video Event tab of the Properties dialog, choose the Smart resample, Force resample, or Disable resample radio button. *For more information, see [Accessing event properties](#) on page 136.*
- To resample the project, choose **Render As** from the **File** menu. In the Render As dialog, click the Custom button to access custom rendering settings. Select the Resample the frame rate of all video check box. *For more information, see [Customizing the rendering process](#) on page 275.*

The original media file looks something like this over three frames.



To convert these three frames into nine frames for a faster frame rate, Vegas software must generate the intervening frames.



Without resampling, the intervening frames are simply the previous frame repeated.



With resampling, the intervening frames are interpolated from the source frames. It is similar to a crossfade effect between the original frames.

Resampling at either the event or project level perform the same function. There are few cases where resampling may be particularly important:

- When the frame rate of the source media for an event is slower than the project's frame rate. For example, when you are using a source media file that has a 10 fps rate in a 29.97 fps rate project, resampling is recommended.
- When changing the speed of a video event. For example, when slowing a clip to 30% using a velocity envelope, resampling is recommended.
- When creating vertically scrolling titles.

When any of the above situations are true, there are only ten frames of source material for every second of project time. When the project is rendered, there must be roughly thirty frames in each second. The frames must be created between the source media frames, sometimes known as padding. The easiest way to do this is to simply duplicate the previous frame. This can result in less than smooth video playback. Resampling allows Vegas software to interpolate the intervening frames more smoothly.

Using Edit Decision Lists (EDL)

Vegas Edit Decision Lists (EDL) are text lists of all of the media files used, where they are placed, and how they are trimmed. Vegas EDLs are not the same as those used in traditional linear editing suites and are not intended as a project interchange for other editing applications.

Creating an EDL

1. From the **File** menu, choose **Save As**. The Save As dialog appears.
2. From the Save as type list choose EDL Text File (.txt).
3. Enter a name for the file and browse for a destination.
4. Click Save.

You can open EDLs created in another application in order to work with a rough copy of a project. For example, you could create an EDL from a project in a third-party editing application and then import the project into Vegas software via the EDL. For best results, save the EDL file and source media files in a single folder before opening the EDL.

Opening an EDL

1. From the **File** menu, choose **Open**.
2. Locate the EDL file, select it, and click the Open button. If you are working on another project, you are prompted to save your work before a new project is opened.

Note: *EDLs do not contain any information about the location of source media. Therefore, the EDL file should be saved in the same directory as the source media. If it is not, or if media is stored in a number of different locations, you are prompted to relink these files when the EDL is imported.*

Because of the significant differences between editing applications, third-party EDL files may not bring all of the project data into Vegas software. Among other differences, events are inserted into the timeline on a single track, all transition effects are replaced with crossfades, and only four audio tracks can be imported.

Working in DV format

Vegas software is optimized for DV editing. If your project is destined for tape or television, the DV format is an excellent choice. The Sony Pictures Digital DV codec provides video with excellent image quality, even over multiple generations, and provides audio that is better than CD-quality. If you start with well-shot DV footage and stay within the DV format throughout the editing process, you can output broadcast-quality video programs. This section provides guidelines for working in the DV format.

Selecting source media

Wherever possible, use DV source video clips. You can capture video from DV cameras and decks using an IEEE-1394 card with no quality loss. You can also convert analog footage to DV using a media converter or by passing the video through a DV camcorder.

Setting project properties

Set your project to match the DV format of your final output. This provides a true WYSIWYG view of the project when you use an external monitor for previewing. This also prevents you from stretching output or changing field order unnecessarily. You can match the project settings to a DV source file by using the Match Media Settings button () in the Project Properties dialog. *For more information, see [Setting video properties based on a media file](#) on page 38 and [Modifying project video properties](#) on page 201.*

Selecting templates

Always select a DV template when performing any of the following tasks in a DV project:

- prerendering video (pg. 255)
- rendering to a new track (pg. 116)
- printing video to tape from the timeline (pg. 284)
- rendering a project (pg. 271)



Rendering to a new track and printing video to tape from the timeline are only available in the full version of Vegas software.

When prerendering video or rendering to a new track, a DV template not only optimizes playback performance, but also helps you avoid needless recompression of DV footage. DV material is recompressed only when necessary. Cuts-only DV sequences are not recompressed when you output the project to DV from the timeline or in Video Capture.

The DV templates are designed to provide high quality, pixel aspect-correct, DV-compliant renders when rendering a project or printing to tape from the timeline. Do not select an uncompressed setting when choosing rendering or print-to-tape options. An uncompressed setting produces a large file that will not print back to DV tape from Video Capture or from the timeline.

Eliminating out-of-range colors

The DV format allows color values to exceed broadcast NTSC and PAL color level standards. If you have a scene whose colors are too hot, or if you want to be sure that your video stays within legal broadcast levels, apply the Broadcast Colors effect to specific events or the entire project.

Be aware that applying the Broadcast Colors effect results in recompression of the video. As a result, render times can increase significantly when the effect is applied to the entire project.

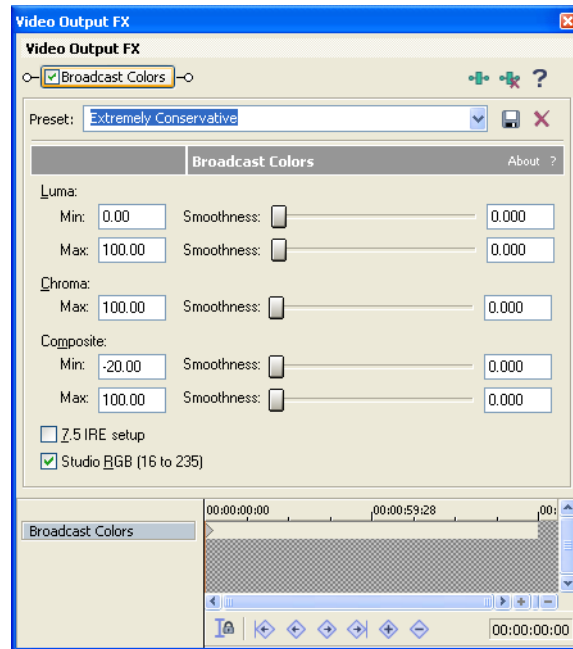

Modifying video properties

Modifying project video properties

You can access project video properties by clicking the **File** menu and choosing **Properties** or by clicking the Project Video Properties button () on the Video Preview window. Many of these settings are identical to the settings found on the Project tab of the Custom Template dialog. Final render properties set up in the Custom Template dialog override the following Project Properties settings. *For more information, see [Video tab on page 276](#).*

These properties control all of the default settings for your project. Without making any changes, these are also the settings that are used to create a final rendered movie file.

- Select a preset template from the Template drop-down list to automatically configure the remaining video controls in this dialog. Many popular formats are included, but you should consult your hardware manuals if you have any questions. You can also save your own custom template.
- Click the Match Media Settings button () to set your project properties to match the properties of a media file of your choosing.
- The values in the Width and Height boxes set the frame size of your final movie.
- Choose an option from the Field Order drop-down list to set the field order. Choose None (Progressive) for video to be viewed on a computer monitor. For DV output, choose **Lower Field First**. If the output is jittery or shaky, or your hardware's manual specifies it, choose Upper Field First. *For more information, see [Interlacing and field order on page 322](#).*
- Choose the pixel aspect ratio for the final movie's destination from the Pixel aspect ratio drop-down list. *For more information, see [Pixel Aspect Ratio on page 333](#).*
- Choose a frame rate for the final movies destination from the Frame rate drop-down list. *For more information, see [Frame Rate \(Video\) on page 331](#).*
- Choose a rendering quality level from the Full resolution rendering quality drop-down list. For most projects, **Good** is the recommended setting. If you have critical material where nothing but the highest quality rendering will do, select **Best**. Please note that rendering time may increase dramatically as large amounts of extra processing is required for the **Best** setting.
- Some effects and transitions can involve motion or animation. The Motion blur type drop-down list allows you to select whether the frames are blurred slightly to create the illusion of motion on individual frames. This can make computer generated animation appear more smooth and natural. Gaussian is the best choice in most situations where blurring is required.
- The Deinterlace method drop-down list provides several options relating to interlacing. Source video from a television is interlaced. When Vegas software renders effects, it needs to deinterlace the two fields that make up a frame. You can choose the exact method used in this list. If you choose the None option, the fields are left interlaced. If you choose the Blend option, contents are used from both fields, which is a good choice for high-detail, low-motion material. If you choose the Interpolate option, a single field is used at a time, which is good for low-detail, high-motion material.
- Choose the location for saving prerendered preview files in the Prerendered files folder box. *For more information, see [Prerendering video on page 255](#).*
- Select the Start all new projects with these settings check box to always use these settings for new projects.

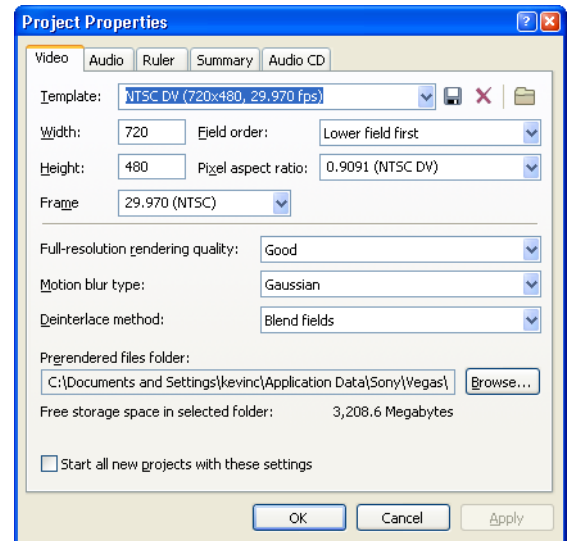

Modifying media file properties

Vegas software tries to automatically detect the properties of your media files. In most cases, these properties do not need to be modified, but there are times when you may need manual control over some of these attributes, depending on the type of file and your specific hardware configuration.

1. Right-click a file in the Media Pool or an event on the timeline and, from the shortcut menu, choose Properties.
2. Modify the parameters on the Media tab as needed. See [Setting general media properties on page 202](#) and [Setting custom stream properties on page 203](#).
3. Click OK.

Setting general media properties

The following general properties appear in the top of the Media tab:

- The File name box displays the file name (cannot be edited).
- The Tape name box displays the name of the tape for media files captured in Video Capture. You can edit the name here or in the corresponding column in the Edit Details window.

Setting timecode media properties

These properties appear in the Timecode section of the Media tab:

- The Use timecode in file radio button is the default setting, where the media file's timecode is used.
- The Use custom timecode radio button allows you to set the media file's timecode manually.
- If you have selected the Use Custom timecode radio button, a drop-down list contains the available timecode formats. SMPTE Drop (29.97 fps, Video) for example, is the timecode format for NTSC DV. Changing the timecode format does not change the source media file in any way. It merely changes how the file is measured in time. *For more information, see [Timecode on page 324](#).*

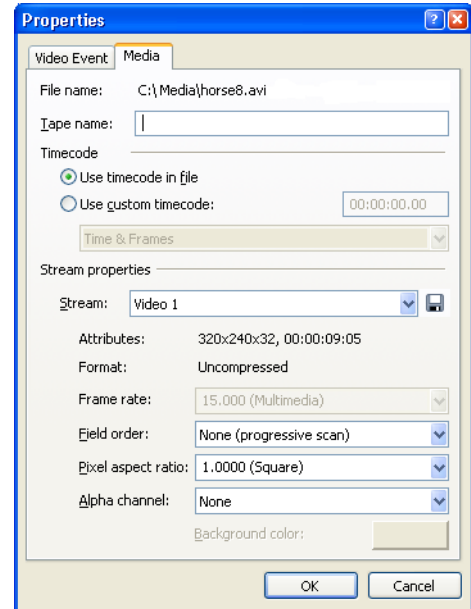

Setting custom stream properties

Media files are opened with a set of default values based on the media file type. When you change any of the values for a media file, these changes are saved for that file in the current project only. If you want to change the default settings for a particular type of video file whenever that type of file is used, click the Save settings to video profiles for future auto-detection button () to the right of the Stream list. This adds an entry to a file called vegas video profiles.ini that can be referenced for future use.

The following properties appear in the Stream properties section of the Media tab:

- If the file has more than one stream of the given type, you can choose the particular stream to work with from the Stream drop-down list.
- The Attributes, Format, and Frame rate boxes display basic information about the file.
- Choose an option from the Field order drop-down list to control how the video field order is handled on a television monitor. Choose None (Progressive) for video to be viewed on a computer monitor. For DV output, choose **Lower Field First**. If the output is jittery or shaky, or your hardware's manual specifies it, choose Upper Field First. *For more information, see [Interlacing and field order](#) on page 322.*
- While you can choose a different value from the Pixel aspect ratio drop-down list, this value should always match the source video's properties.
- The option selected in the Alpha channel drop-down list determines how transparency is handled in a file. The default alpha channel setting for most video files is None. PNG image files can have an alpha channel that is automatically detected. The options in this drop-down list are described below.

Alpha channel option	Description
Undefined	Because the image format provides no alpha channel information, this setting ignores any alpha channel information in the file.
None	Either there is no alpha channel or there is an alpha channel but it's completely opaque (solid).
Straight (unmatted)	Transparency information is maintained in only the alpha channel. Alpha information must be applied to the RGB channels before compositing.
Premultiplied	The standard method of handling alpha information. Transparency information is maintained in the alpha and RGB channels, and the image is ready for compositing. No RGB component exceeds the alpha value.
Premultiplied (dirty)	Similar to Premultiplied , but RGB components may exceed the alpha value. This option is used mainly for images created by 3D applications involving compositing of 3D images over a non-solid color image background.

Modifying output properties

You can adjust final output properties when you render your movie. *For more information, see [Creating custom rendering settings for AVI files](#) on page 276.*



Using Video FX, Compositing, and Masks

Video plug-ins in Vegas® software include effects and generators. Effects cover a broad range of electronic modifications that can be used to improve substandard video or artistically enhance a production. Generators can be used to create custom video events such as credit rolls or gradient overlays.

A variety of options are provided in compositing video and using masks. Compositing involves mixing visual elements together into a final output. Multiple compositing modes are provided from which to choose. Masks, which are used extensively in television and movies, are an important part of creating overlays. Together, these professional tools can help you polish your productions.

Note: *The compositing model in Vegas 5.0 software differs significantly from the Vegas 4.0 model. To reproduce the Vegas 4.0 parent/child masking behavior, set the compositing mode of the parent track to Multiply, and then apply the Mask Generator plug-in as a track effect on the parent track.*

Using video effects

A great variety of video effects plug-ins are provided that are ready for you to drag-and-drop onto your projects, media files, tracks, and events. Previews of the different effect presets appear in the Video FX window. In addition to the presets, each plug-in has individual controls that allow you to customize the effects in precise detail. You can also animate video effects using keyframes. *For more information, see [Using keyframe animation](#) on page 237.*

The mix of video effects applied at different levels (to events, tracks, files, etc.) is important to the final mix of a project. *For more information, see [Video signal flow](#) on page 35.*

In general, effects are applied in the following order:

- to files in the Media Pool
- to events
- to tracks
- to the project (video output effects)

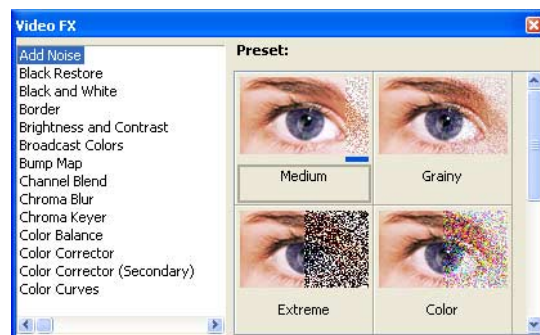



Adding a video effects plug-in

You can apply video effects to events, tracks, files in the Media Pool, or to an entire project. You can add a plug-in by selecting it in the Plug-In Chooser dialog, or you can drag-and-drop the plug-in from the Video FX or Plug-Ins windows.

Adding a plug-in using the Plug-In Chooser

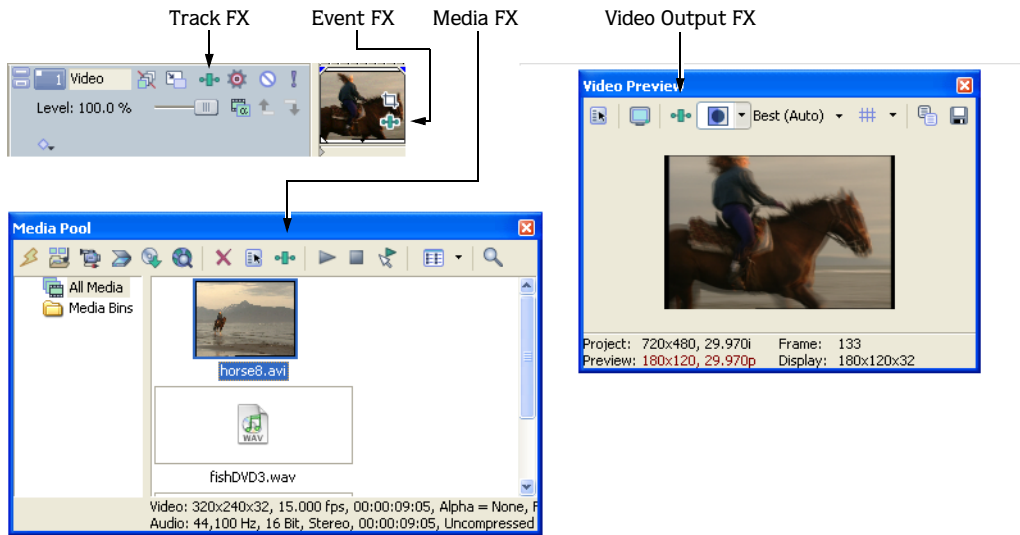
1. Click the Video FX button () in one of the following locations (see the illustration):
 - Media FX are applied before a media file is inserted into an event on the timeline. Every occurrence of this media file in a project has the effect applied to it.
 - Event FX are applied to events on the timeline.
 - Track FX are applied to the output of a particular track.
 - Video Output FX are applied to the final output and affect every event in a project.



2. In the Plug-In Chooser dialog, select the effect that you would like to apply and click OK.
3. Modify the effect in the Video FX window and close the window when you are finished. For help on the different controls in the Video FX window, click the Plug-In Help button () to access online help.

Adding a plug-in from the Video FX or Plug-In Manager window

1. If the Video FX or Plug-In Manager window is not currently visible, choose either Video FX or Plug-In Manager from the **View** menu to view the appropriate window.

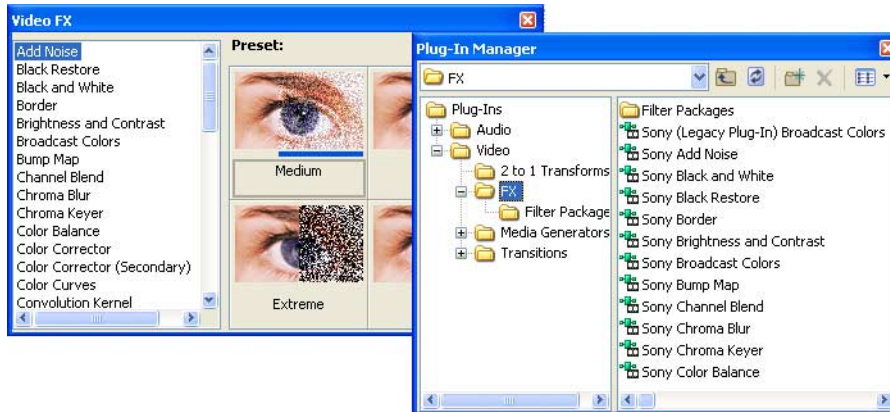

2. Drag a plug-in from the window to one of the following locations:
 - file in the Media Pool
 - event
 - track list or empty section of a track
 - Video Preview window (video output effects)
3. Modify the effect in the Video FX window and close the window when you are finished. For help on the different controls in the Video FX window, click the Plug-In Help button () to access online help.

Working with video effects plug-in chains

You can apply plug-ins in chains of two or more for even greater flexibility. A plug-in chain is a sequence of all of the plug-ins to be applied to a media file, event, track, or project. The same plug-in can be added to a chain more than once. Use the same steps to add additional plug-ins to a chain as you use to add a single plug-in. For more information, see [Adding a video effects plug-in](#) on page 206.

After you apply a plug-in chain, the video is processed by each plug-in in order. The plug-ins are cumulative so, in some cases, you may want to rearrange their order to achieve the desired effect.

To view and work with a plug-in chain, click the Video FX button (•+•) for the event, track, Media Pool file, or Video Preview window to open the Video FX window.

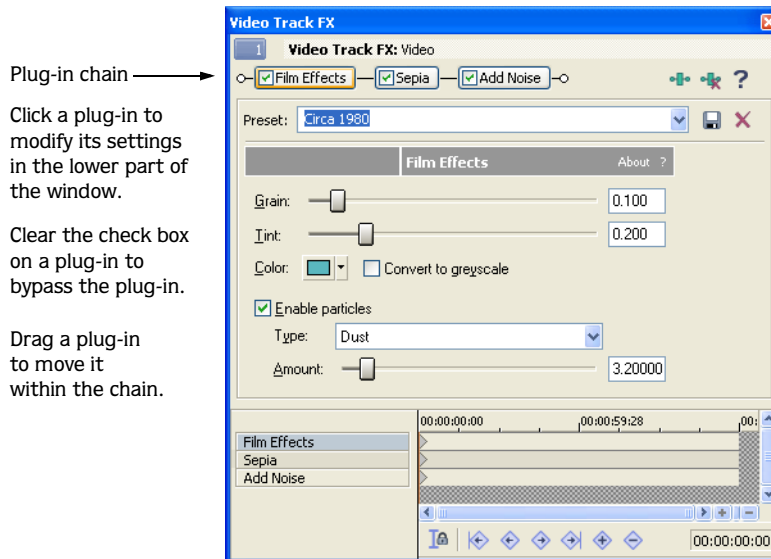

Bypassing plug-ins

Video effects plug-ins can also be temporarily bypassed (turned off) by deselecting them (clearing the check box on the plug-in). Since the effects are rendered very quickly in the Video Preview window, turning a plug-in on and off allows you to see the results of the plug-in on your project.

Changing the plug-in order

Video effects plug-ins are applied in the order that they appear in the chain. You can change this order by dragging a plug-in to a new location in the chain. Alternately, you can click the Plug-In Chain button (•+•) in the Video FX window and reorder the plug-ins in the Plug-In Chooser dialog.

In the following illustration, you can see how the order of plug-ins is important.

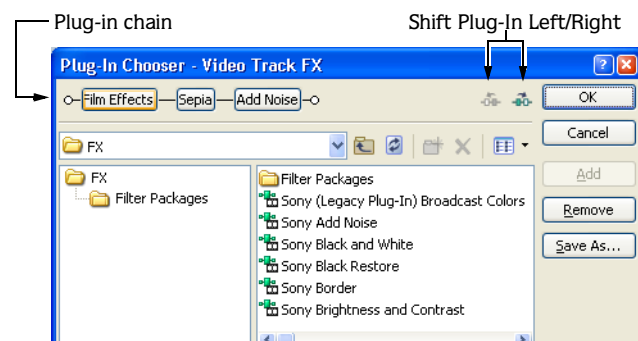

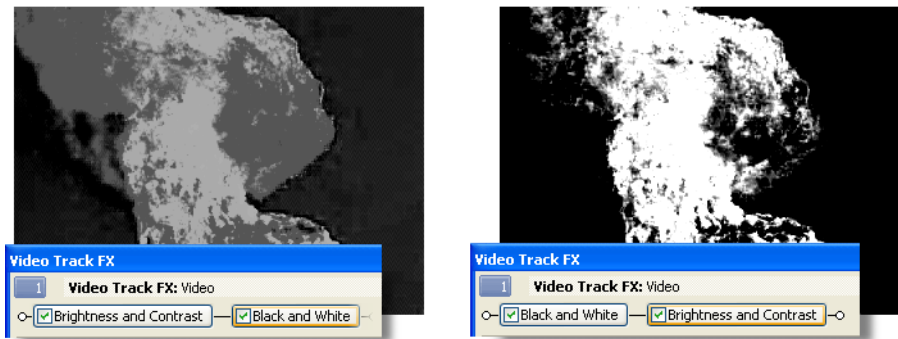

The goal of the above example is to use video effects plug-ins to create a very high-contrast mask out of a video clip of fire. In the image on the left, a Brightness and Contrast plug-in is applied first and then a Black and White plug-in. In the image on the right, the Black and White plug-in was applied first, removing the color, and then the Brightness and Contrast plug-in was applied. The mask created by the second example is much cleaner, even though all of the settings of the two plug-ins are identical.

Processing plug-ins on events with panning or cropping

When you add a plug-in to a video event that has panning or cropping applied to it, you have the choice of processing the plug-in before or after the pan/crop. For example, you might want to apply a Radial Blur plug-in before the video is cropped and then a Noise plug-in is applied after the cropping is complete.

You can choose whether an effect is applied pre- or post-pan/crop in the keyframe controller at the bottom of the Video FX window. Click the Before/After Pan/Crop button to the left of the effect name to determine whether the effect is processed before (◀) or after (▶) Vegas software pans or crops the event.

Here, the Deform plug-in is applied before the pan/crop. The Glow and Color Curves plug-ins are applied after the pan/crop.

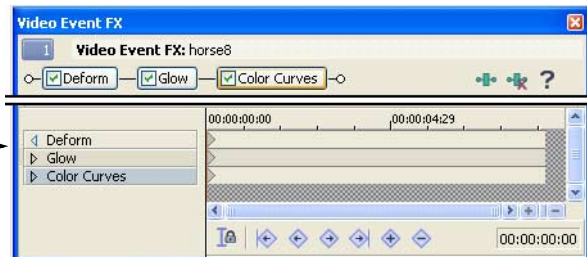

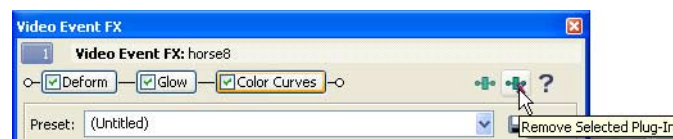

Removing a plug-in

1. Click the FX button (+) on the event, track, Media Pool file, or Video Preview window that has the plug-in applied to it. The Video FX window appears.
2. Click the plug-in that you want to remove.
3. Click the Remove Selected Plug-In button.



Modifying a video effects plug-in

Video effects plug-ins are highly customizable. You can select from a variety of presets or adjust the settings for custom effects. You can also save custom settings to be used again as a new preset.

1. Click the FX button () on the event, track, Media Pool file, or Video Preview window that has the plug-in applied to it. The Video FX window appears.
2. Select a preset from the Preset drop-down list or adjust the parameters as needed. For help on the different controls in the Video FX window, click the Plug-In Help button () to access online help.

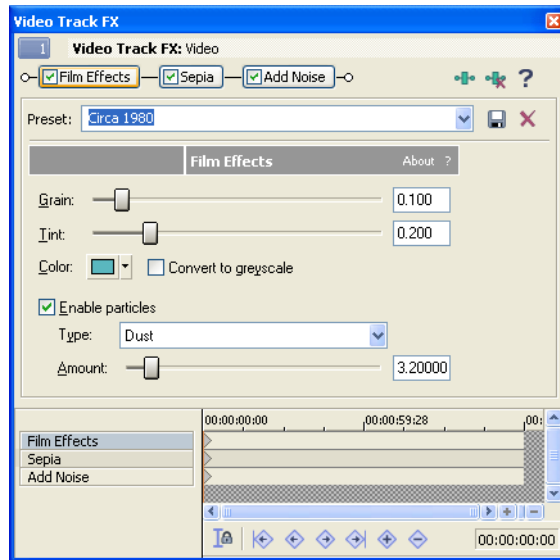

Changes you make are automatically updated in the Video Preview window, using the current cursor position as the example. To see the effect as applied to the video in motion, create a time selection (looped region) and preview in loop playback.

Saving custom plug-in settings as a preset

1. Click the Preset text box. The name of the current preset is highlighted.
2. Type a new name for the preset and click the Save button ().

Tip: To use a saved custom preset, simply choose it from the drop-down list.

Using keyframe animation with plug-ins

You can use keyframe animation to control a plug-in over time. Keyframes are added to the keyframe controller at the bottom of the Video FX window. Since a number of plug-ins can be added to a single event, track or project, click the plug-in's button in the chain and modify the particular attributes and keyframe controller for that plug-in. For more information, see [Using keyframe animation on page 237](#) and [Animating video effects plug-ins on page 243](#).

Using generated media

Generated media plug-ins are a special class of plug-in that creates virtual media files contained in events on the timeline. These virtual files are stored in the Media Pool, where their properties can be viewed and modified.

Generated media provide an easy way to add text, backgrounds, or test patterns to your project. You can view the generators by choosing **Media Generators** from the **View** menu to display the Media Generators window.

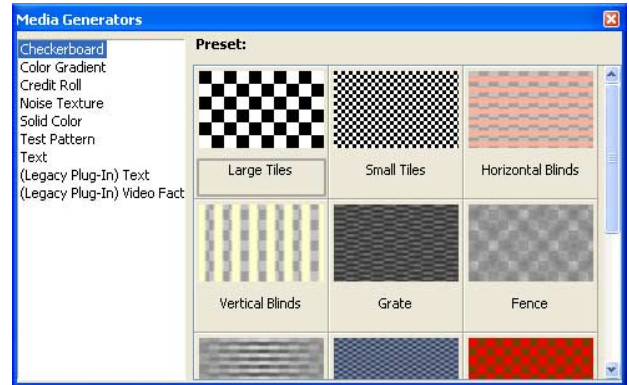

Generated media events can be animated using keyframes. For more information, see [Using keyframe animation](#) on page 237 and [Animating generated text](#) on page 244.



Generated media	Description
Checkerboard	Creates checked and striped patterns.
Color gradient	Creates gradient colored events to be used behind overlays, as masks, or for fades.
Credit roll	Creates events that format your text into credits. Text can be formatted within the Video Event FX dialog in Vegas software, or pasted into this dialog from a word processing program.
Noise texture	Creates realistic-looking textures.
Solid color	Creates solid colored events to be used behind overlays or for fades.
Test pattern	Creates standard test patterns that can be used to calibrate your video output stream. Many studios and broadcast facilities require a color bar pattern at the beginning of your video so that engineers can calibrate their equipment.
Text	Creates events containing text for titles or simple credits. Text can be formatted with color, shadows, and other effects.

Adding a generated media event

You can add a generated media event by choosing **Generated Media** from the **Insert** menu. This adds the event at the cursor position in the selected track. However, perhaps the simplest way to add generated media is through drag-and-drop.

1. From the **View** menu, choose **Media Generators**. The Media Generators window displays.
2. Drag a generator from the Media Generators window to the project. The mouse cursor changes to indicate when you can drop the generator.
3. Modify the generator in the Video FX window and close the window when you are finished. To modify settings at a later time, click the Generated Media button () on the event. For help on the different controls in the Video FX window, click the Plug-In Help button () to access online help.

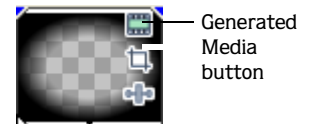

Tip: A generated media event is ten seconds long as a default. However, you can trim the event to any length. For more information, see [Trimming an event](#) on page 67.

Duplicating a generated media event

Once you have added a generated media event and modified its settings, you can duplicate it. *For more information, see [Duplicating events](#) on page 67.*

When you duplicate a generated media event, you have two options:

- Select the Create a new copy of the source media radio button if you want the new event to be modified on its own. The new event is completely independent of the original event.
- Select the Create a reference to the original media radio button to keep the new event linked to the original generated media event. Any change to either event is mirrored in the other.

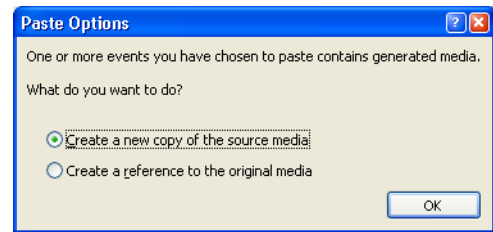

Compositing

Compositing is the process of mixing visual elements together into a final output. In Vegas software, this means mixing tracks together vertically. Masks, generated text, and chroma keying all involve compositing. Understanding how compositing works is important to understanding these and many other video track mixing techniques.

Understanding the parent/child track relationship

The key to understanding overlays, masks, transparency, and compositing is to understand the parent/child relationship between tracks. In general terms, the parent track is the highest track in a group of tracks (often only two) and the behavior of the child tracks (i.e., how they are composited together) is determined by the parent track.

You can also produce complex compositing by creating nested parent/child groups with compositing parents and children at various levels.

When you have multiple levels of parent and child tracks, clicking the Make Compositing Child button (↓) moves the track in one level and clicking the Make Compositing Parent button (↑) moves out one level.

Hold **Ctrl** while clicking the Make Compositing Child button to move a track and all its child tracks in one level.

The following three examples demonstrate different compositing relationships.

The first example shows two independent tracks. The top track contains a generated text event that has a transparent background. The second track therefore shows through the transparent areas in the Video Preview window. Since the second track does not have any transparent areas, any tracks below it would be completely obscured.

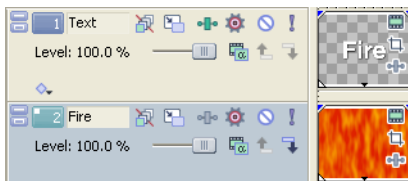
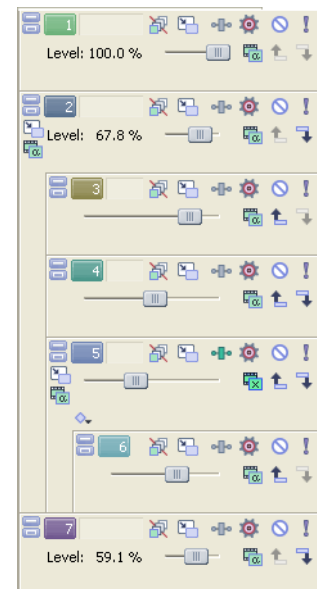

In the second example, track two is the child track of track one (the parent track), and the compositing mode of track one is set to **Mask**. This parent/child relationship was set up by clicking the Make Compositing Child button () in the track list for track two. This makes the text in track one act as a mask over track two, allowing the fire to show through the mask (i.e., the text). The region outside of the text is still transparent, but there is nothing below these tracks, so it appears black.

 *Parent/child video track grouping using the Make Compositing Child button is only available in the full version of Vegas software.*

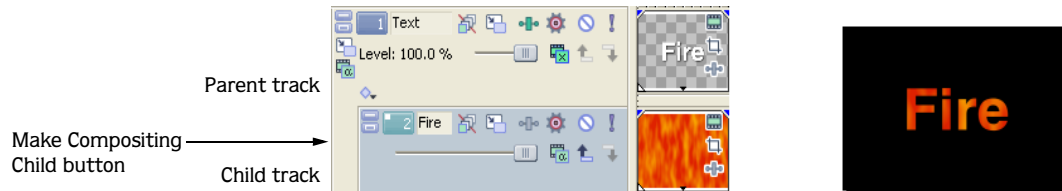

In the third example, a generated media event was added to the track below the first two tracks, which are already paired in a parent/child relationship. The color gradient event in track three shows through the transparent area of the top two paired tracks.



Selecting compositing modes

The Compositing Mode button () determines how the transparency in a video track is generated. Since lower tracks show through higher tracks, it is the compositing mode of the *higher* track that determines how much of the *lower* track shows through.

Note: *The compositing mode of the lowest video track is a special case. Selecting a mode for the lowest track affects its transparency against a black background.*

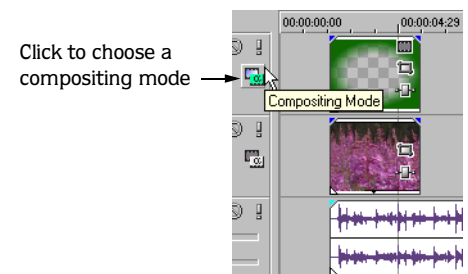





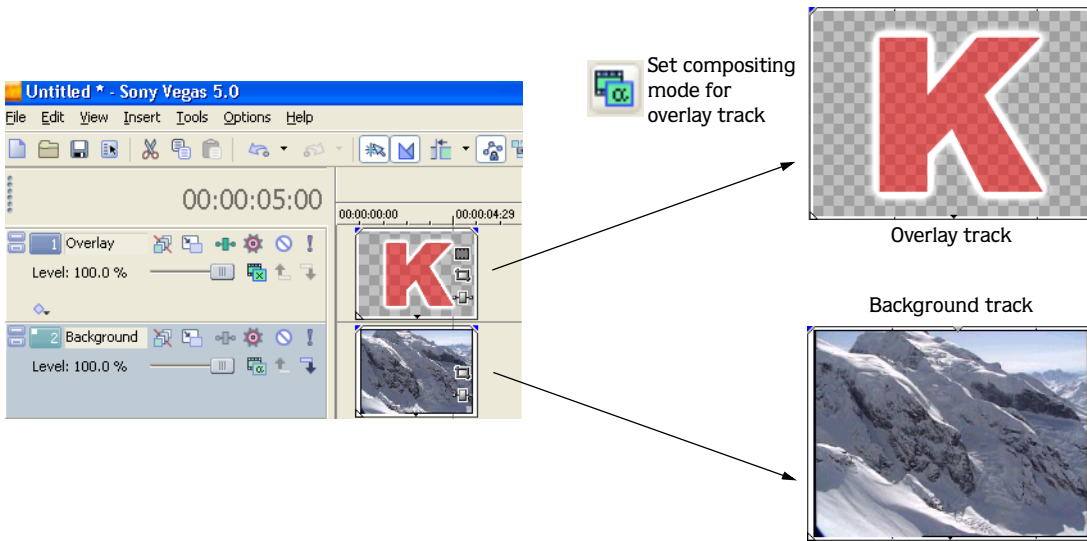



To select a compositing mode, click the Compositing Mode button and choose a mode from the menu that appears, or choose **Custom** to customize compositing with a 2-to-1 transform plug-in.

The sample below uses a generated text event that is partially transparent. For more information, see [Using generated media](#) on page 211.



The following table shows how these two sample tracks are blended using each of the compositing modes.

Compositing mode	Sample	Description
Add		Adds the overlay color values to the background.
Subtract		Subtracts the overlay color values from the background.
Multiply (Mask)		Multiplies the overlay color values by the background color values. This makes overlay colors stronger and more present and results in a darker video image. The opposite of this mode is Screen.
Source Alpha		Uses the alpha channel to determine transparency in the overlay. This compositing mode is based on the alpha channel characteristics of an event or media file. If no alpha channel is present in the overlay, the Source Alpha compositing mode has no effect.
Cut		Cuts out the overlay color values from the background.
Screen		Multiplies the inverse of the overlay color values with the background color values. This makes overlay colors weaker and less present and results in a lighter video image. The opposite of this mode is Multiply.

Compositing mode	Sample	Description
Overlay		Heightens contrast by using Multiply mode on darker colors and Screen mode on lighter colors.
Hard Light		Adds overlay colors as if the overlay were lit by a bright, focused spotlight.
Dodge		Brightens the background based on the overlay color values.
Burn		Darkens the background based on the overlay color values.
Darken		Compares the overlay and background pixel by pixel and selects the darker color value for each pixel.
Lighten		Compares the overlay and background pixel by pixel and selects the lighter color value for each pixel.
Difference		Compares the overlay and background pixel by pixel and subtracts the darker color value from the lighter color to generate a new color value (difference).
Difference Squared		Remaps color values along a parabolic curve. The color values of the layers in the composite group are subtracted, and then the subtracted values are squared. The resulting image will have less extreme changes in color values as the colors approach black (RGB 0,0,0) and more extreme changes in color values as colors approach white (RGB 255,255,255).

Adjusting opacity with the composite level slider

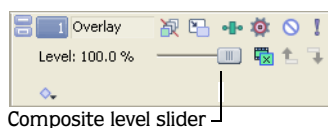

You can precisely control the transparency or blending of the overlay with the composite level slider. Left is transparent and right is 100% opaque. You can also double-click the current value to enter a specific numeric percentage.

Using a 2-to-1 transform plug-in to customize compositing

Click the Parent Composite Mode () or Composite Mode button and choose **Custom** from the menu to use plug-ins to control how the parent track modifies the tracks in its composite group.

The included Displacement Map, Height Map, and Bump Map plug-ins can create interesting lens, mirror, water, fire, and other light-bending effects. These plug-ins are explained below:

- **Displacement Map:** Uses the parent image as a guide to offset the pixels in the composited child tracks along the horizontal and vertical axes. The X and Y offsets are independently encoded in the image color channels.
- **Height Map:** Uses the parent image as a guide to offset the pixels in the composited child tracks. The gradient of the image in the parent track is used to determine the amount of offset for the image displayed at that location, much like how light bends through a lens.
- **Bump Map:** Uses the parent image as a guide to add texture and lighting to the composited child tracks. The texture of the bump map is applied to the composited child tracks: light sections of the map represent high areas, and dark sections represent low areas.

3D Compositing

With 3D compositing, you can move video tracks anywhere in space to simulate realistic motion and lighting.

With 2D compositing (and in previous versions of Vegas software), you can move video or images along the X or Y axes, and you can rotate video along the Z axis. With 3D compositing, you can move or rotate along the X, Y, or Z axes to create distance, depth, and perspective.

There are two basic rules to 3D compositing:

1. When you have a 2D track in the track list, 3D tracks below that track are rendered in 3D and then composited as a 2D image.
2. A 2D track at the root level (flush to the left of the track list) acts as a barrier to interaction between 3D tracks.

In the following examples, both text tracks have been rotated in 3D: the “hot” track is rotated toward the user, and the “cool” track is rotated away from the user.

In the first example, the two tracks intersect along their rotation axis. In the second example, adding a 2D track above the “cool” track causes it to be rotated in 2D and composited as a 2D image so the “hot” text is displayed above it without intersecting.

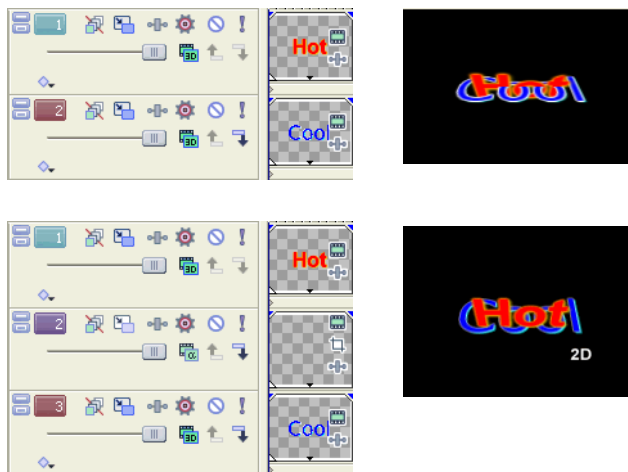

Single-track 3D motion

1. Click the Track Motion button () on the track that contains the overlay that you want to animate. The Track Motion window is displayed.
2. From the Compositing Mode drop-down list, choose 3D Source Alpha.

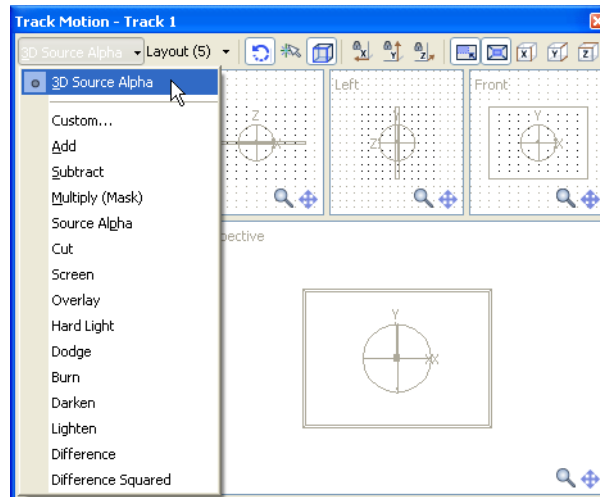

3. Choose a setting from the Layout drop-down list to choose the workspace display that you want to use. The Layout setting allows you to see your track from various points of view.
4. Adjust the selection area to change the viewable area of the track and its position in space. Guides are displayed in bold to indicate how the track will be moved or rotated:

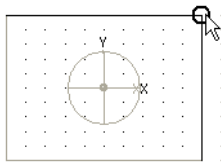

Moving closer to or farther from viewer. Drag across corners to flip the track.

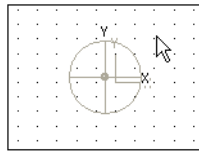

Dragging the track.

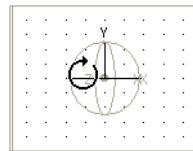

Rotating left to right around the Y axis.

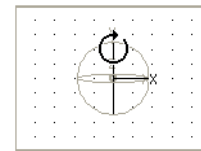

Rotating forward or backward around the X axis.

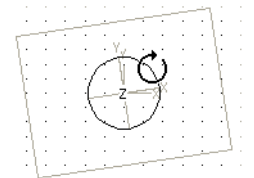

Rotating counterclockwise around the Z axis.



5. Use the buttons at the top of the dialog to allow or prevent movement or scaling. *For more information, see [Changing editing options](#) on page 219.*

Tip: Right-click the workspace to display a shortcut menu that displays commands to restore, center, or flip the selection box. You can also force the box to match the source media's aspect ratio or your project's output aspect ratio. Matching the output aspect ratio can prevent black bars from appearing when you use source media (such as photographs) that does not match your project's aspect ratio.

6. The 3D track motion occurs instantly, and the results are updated in the Video Preview window.
7. Use the keyframe controller at the bottom of the Track Motion window to establish distinct track motion settings throughout the duration of the track.

During playback, immediate frames are interpolated to create smooth motion. Expand the Keyframe interpolation heading on the left side of the window and drag the Smoothness slider to adjust the interpolation. *For more information, see [Using keyframe animation](#) on page 237.*

Composited group 3D motion

1. Click the Make Compositing Child button () on the tracks you want to group to create a compositing group. For more information, see [Understanding the parent/child track relationship](#) on page 212.
2. Click the Parent Composite Mode button () on the parent track and choose 3D Source Alpha.
3. Click the Parent Motion button () on the parent track. The Track Motion window is displayed.

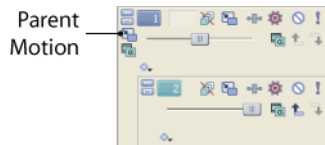

Parent track motion affects the parent track and all child tracks.

In the sample track list to the right, parent track motion on track 1 will affect tracks 1 through 6.

Parent track motion applied to track 4 will affect only tracks 4 through 6.

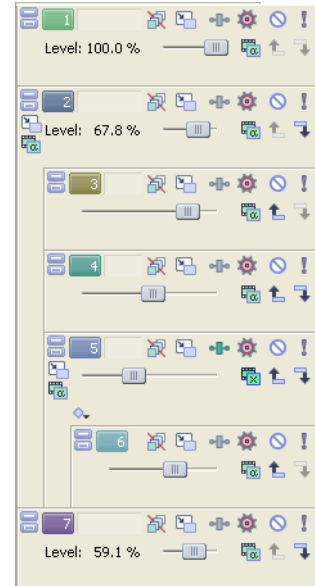

4. Choose a setting from the Layout drop-down list to choose the workspace display you want to use. The Layout setting allows you to see your track from various points of view.
5. Adjust the selection area to change the viewable area of the track and its position in space. Guides are displayed in bold to indicate how the track will be moved or rotated:

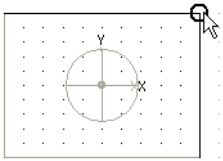

Moving closer to or farther from viewer. Drag across corners to flip the track.

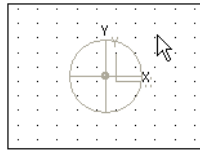

Dragging the track.

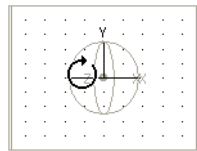

Rotating left to right around the Y axis.

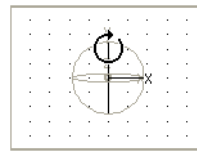

Rotating forward or backward around the X axis.

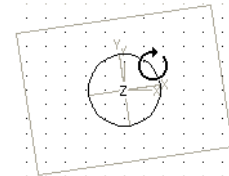

Rotating counterclockwise around the Z axis.

6. Use the buttons at the top of the dialog to allow or prevent movement or scaling. For more information, see [Changing editing options](#) on page 219.











Tip: Right-click the workspace to display a shortcut menu that displays commands to restore, center, or flip the selection box. You can also force the box to match the source media's aspect ratio or your project's output aspect ratio. Matching the output aspect ratio can prevent black bars from appearing when you use source media that does not match your project's aspect ratio.

7. The 3D track motion occurs instantly, and the results are updated in the Video Preview window.
8. Use the keyframe controller at the bottom of the Track Motion window to establish distinct track motion settings throughout the duration of the track.

During playback, immediate frames are interpolated to create smooth motion. Expand the Keyframe interpolation heading on the left side of the window and drag the Smoothness slider to adjust the interpolation. For more information, see [Using keyframe animation](#) on page 237.

Changing editing options

Use the toolbar at the top of the Track Motion window to change your editing options.

Icon	Command	Description
	Enable Rotation	Select this button if you want to be able to rotate, or spin, the video. When the button is not selected, video is locked so you can move it along the X, Y, or Z axis, but the event will not rotate.
	Enable Snapping to Grid	Select this button if you want your editing to snap to the grid.
	Edit in Object Space	Select this button if you want to edit in the object's space rather than the camera's space. For example, if a video object is rotated, its X axis may not correspond to the X axis of the of the Video Preview window. Selecting the Edit in Object Space button in conjunction with the Prevent Movement buttons allows you to move the object along its own X, Y, and Z axes.
	Prevent Movement (X)	Select this button if you want to prevent horizontal movement of the track.
	Prevent Movement (Y)	Select this button if you want to prevent vertical movement of the track.
	Prevent Movement (Z)	Select this button if you want to prevent movement of the track along the Z axis (closer to or farther from the viewer).
	Lock Aspect Ratio	Select this button if you want the selection box to retain its aspect ratio during resizing. When the button is not selected, the height and width can be resized independently.
	Scale About Center	Select this button if you want the selection box to retain its center point when you resize the box by dragging its edges. When the button is not selected, the opposite side of the selection box will remain anchored when you drag the edges to resize it.
	Prevent Scaling (X)	Select this button if you want to lock the horizontal dimension of the selection box.
	Prevent Scaling (Y)	Select this button if you want to lock the vertical dimension of the selection box.
	Prevent Scaling (Z)	Select this button if you want to lock the Z-axis dimension of the selection box.

Examples of various 3D compositing scenarios

In the following examples, track two (blue-and-yellow checkerboard) is rotated forward in 3D space, track 4 (green-and-gray checkerboard) is rotated backward in 3D space, and track 3 (red-and-white checkerboard) is a 2D track.

Track 1 is used to rotate tracks 2 through 4 so you can see the compositing interaction.

In the first example, the 2D track is a compositing child to track 2. The 2d child is inserted in the composited output at a depth of zero on the Z axis, and tracks 2 and 4 intersect in 3D space..

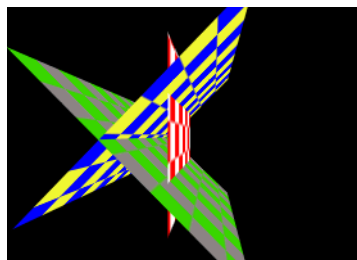

In the next example, clicking the Make Compositing Parent button on track 3 forces the track below (at the same compositing level) to be rendered in 3D and composited as a 2D image.

Track 4 (green-and-gray checkerboard) now has the appearance of depth—the checkerboard tapers to a vanishing point—but is inserted in the composited output as a 2D image at a depth of zero on the Z axis. Track 2 is still rotated in 3D space.

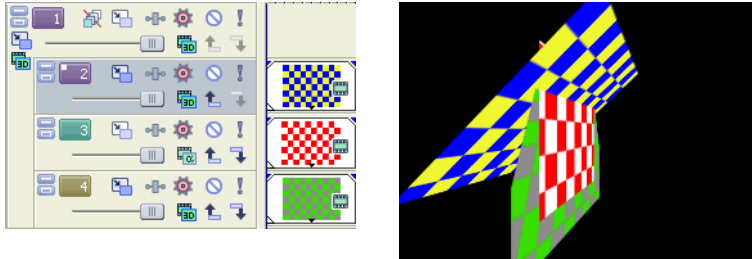

In the next example, clicking the Make Compositing Parent button on track 3 again forces the track below (at the same compositing level) to be rendered in 3D and composited as a 2D image. However, in this case, the 3D rotation that was applied as parent motion on track 1 is not applied to tracks 3 and 4.

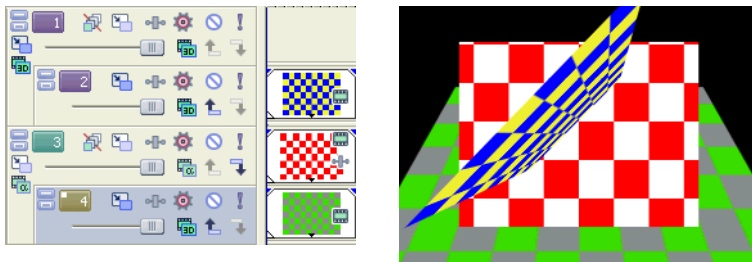

In the next example, all tracks are compositing parents. The 3D track on track 2 is on top, the 2D track in track 3 is composited below track 2, and the 3D track in track 4 is composited below tracks 3 and 4.

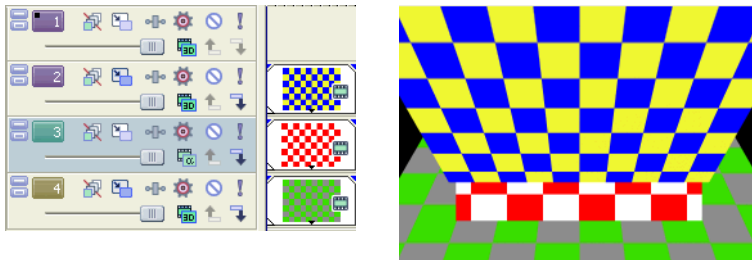

Creating masks

Masks are used to create overlays, limit the effects of a filter, and to create transparent titles. In their simplest form, masks work by making a particular color in an image or video transparent. More complex effects can be created with gradients (smoothly blending transparent areas together) and by altering the sensitivity of the mask.

 Parent/child video track grouping using the Make Compositing Child button is only available in the full version of Vegas software.

Creating image masks

You can use media generated by Vegas software to create simple masks. You can also create masks from just about any image file.

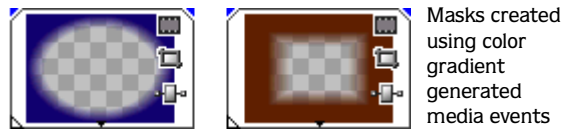

Masks created using color gradient generated media events

1. Create an image of a solid white circle on a black background in any paint program. This will be the mask.
2. Add the mask image file as an event into the top-most track on the timeline.
3. Insert a video event just below the mask track. This is the background video behind the mask and is the event that is masked.
4. Click the Make Compositing Child button () located in the track list of the background video (lower) track. This makes the lower track the child of the mask track (the parent track).

In the following example, the white circle is a BMP image file. Black is 100% opaque and white is completely transparent.

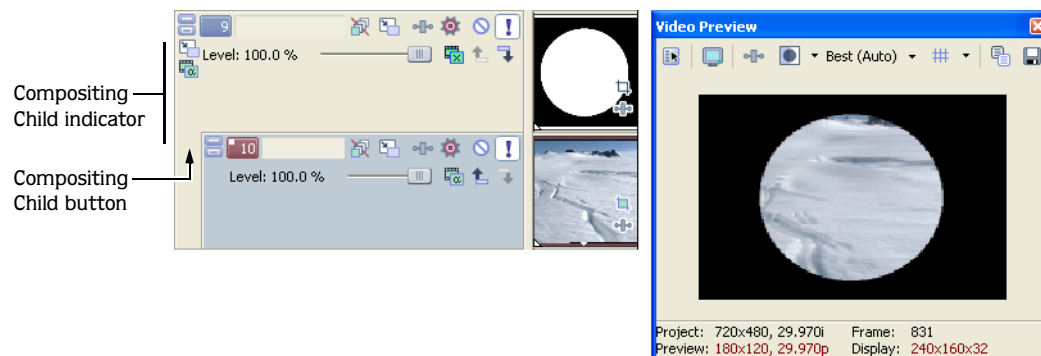

Masks can also be partially transparent. By using gradients and grayscale images, you can achieve smooth blending. Black is still 100% transparent and white is opaque, but the grays in between are only partially opaque.

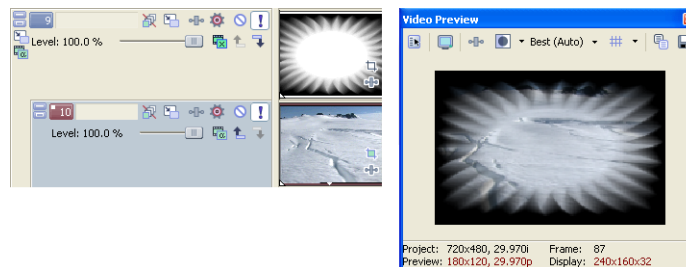

The effects of the masks are very clear in these examples, but this is not how they would actually be used in a real production. Masks are commonly used to isolate a portion of the video from an effect. Masks do not need to be black and white, or grayscale, nor do they need to be still images.

Tip: It is best to use images that are the same size as your project's frame size. You may also need to change the pixel aspect ratio of an image file to get it to display correctly. For more information, see [Correcting images for DV pixel aspect ratios](#) on page 190 and [Modifying media file properties](#) on page 202.

Creating video masks

You can also use video files to create masks, although the process can be more complicated than using an image as a mask. The key to any mask is contrast. You can increase the difference between the light and dark areas of a video file using video effects plug-ins.

1. Insert the video that you want to use as a mask into a video track.
2. Drag a Black and White plug-in from the Video FX window to the event to remove the color. *For more information, see [Adding a video effects plug-in](#) on page 206.*
3. Drag a Brightness and Contrast plug-in from the Video FX window to the event.
4. Adjust the Brightness and Contrast to create the mask. Watch the Video Preview window for a real-time preview of the mask. Adjust the effect so that parts of the video are completely black (opaque) and other parts are completely white (transparent). This can often mean increasing the contrast while decreasing the brightness.
5. If necessary, mask areas can be inverted (reversing the black and white areas) with an Invert plug-in or by selecting the Invert check box in the Mask Generator window. *For more information, see [Using the Mask Generator](#) on page 226.*

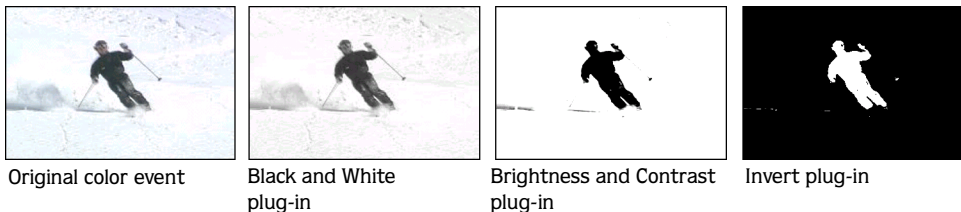
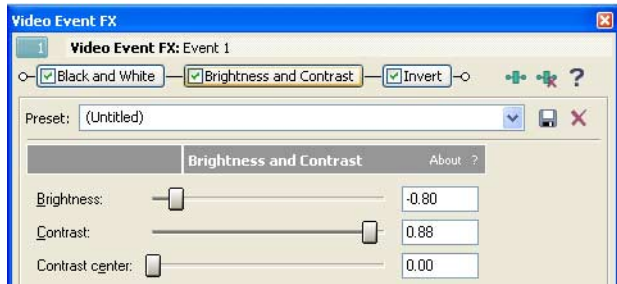

After you have created the mask, place it in the highest track. Add another video event to another track below the mask and click the Make Compositing Child button () on that track. Any video that appears in a lower track below the Parent mask track and its Child shows through the areas outside of the mask. The entire setup is pictured in the following illustration.

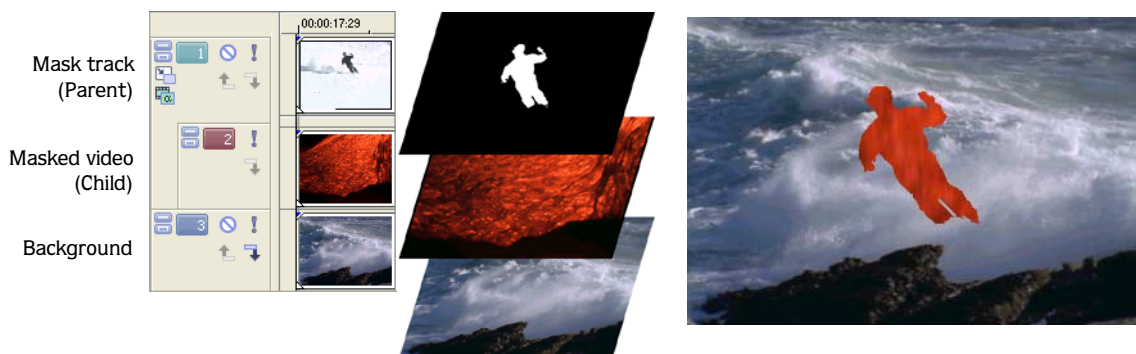

Bézier masks

You can use the Event Pan/Crop dialog to create masks using Bézier curves.

Use the controls in the Path heading on the left side of the Event Pan/Crop dialog to create masks using Bézier curves. Each event can contain multiple Bézier masks.

When you use a single setting for the duration of an event, you are masking the contents of the event. You can add keyframes to change the shape, size, or position of the mask to create an animated effect.

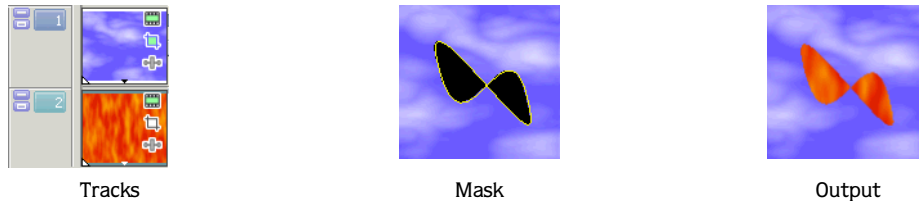

Creating a Bézier mask

1. From the **Tools** menu, choose **Video**, and choose **Video Event Pan/Crop** (or click the Event Pan/Crop button () on the event). The Event Pan/Crop window is displayed.
2. Select the Mask row in the keyframe controller. When the Mask row is selected, Bézier curve-drawing tools are displayed so you can create your mask.
3. Select the Mask check box to apply the mask so you can see the results of your masking in the Video Preview window, or clear the check box to bypass the mask.

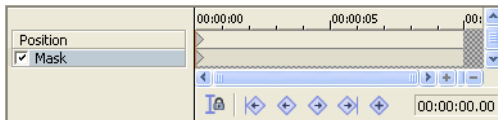













4. Select the anchor creation tool () on the left side of the Event Pan/Crop window and click in the workspace to create a mask. See the following table for a description of the tool's behavior.



Tip: Right-click the curve, choose **Initialize Tangents**, and choose a command from the submenu to smooth the path (or portions of the path) to help you get started with your editing.

Editing the path

Use the tools on the left edge of the Event Pan/Crop window to edit your mask.



Icon	Tool	Description
	Normal Edit	<p>Use to select and edit control points and tangents.</p> <p>Click a point to select it, or drag to move the point.</p> <p>Hold Ctrl while clicking to select/deselect multiple points.</p> <p>Hold Alt and click a segment to select all points on the path. The pointer is displayed as a .</p> <p>Hold Alt+Shift while clicking an anchor point to invert the selection state of each anchor on the path. The pointer is displayed as a .</p> <p>Drag a segment between two anchor points to modify the tangents on each side of the segment. The pointer is displayed as a .</p> <p>Hold Ctrl while clicking an existing point in a closed path to show or hide the tangents. The pointer is displayed as a .</p> <p>Drag a tangent control to manipulate the curve. Both sides of the tangent control move about the anchor point. The pointer is displayed as a .</p> <p>Hold Ctrl while dragging a tangent control to split the halves of the control and adjust them independently or join the two halves of the control if the tangent was previously split.</p>
	Anchor Creation	<p>Use to create control points.</p> <p>Click to create an anchor point. Drag before releasing the mouse button to modify the tangents of the new point.</p> <p>Click the first or last point of an open path to close the path. The tool is displayed as a . Drag before releasing the mouse button to move the entire path.</p> <p>Click between two anchor points to create a new point. The tool is displayed as a .</p> <p>If all paths are closed, click to create a new path.</p>
	Anchor Deletion	<p>Use to remove control points.</p>
	Split Tangent	<p>Use to adjust control point tangents.</p> <p>Click a point to display tangent controls, or click the center of a tangent control to reset it.</p> <p>Drag center of the tangent control to manipulate the curve. Both sides of the tangent control move about the anchor point. The pointer is displayed as a .</p> <p>Drag the point at either end of the tangent control to manipulate that half of the curve. The pointer is displayed as a .</p> <p>Hold Shift while dragging a tangent control to split the halves of the control and adjust them independently or join the two halves of the control if the tangent was previously split.</p>

Setting path options

1. Select a path with the Normal Edit tool .
2. Expand the Path heading on the left side of the window to set options for the selected path.
3. Choose a setting from the Mode drop-down list to choose the selected path's masking behavior.
 - **Positive** — The area inside the path is visible in your video output.
 - **Negative** — The area outside the path is visible in your video output. The area inside the path is transparent.
 - **Disabled** — The path is bypassed.
4. Select the Anti alias box and choose **Yes** or **No** from the drop-down list to indicate whether you want to apply an anti alias filter to smooth the edges of the path.
5. Select the Opacity box and type a value in the box (or click the  to display a slider) to set the opacity of the area inside the path.
6. Select the Feather type box and choose a setting from the drop-down list to fade the edges of the path.
 - **In** — Feathering is applied to the inside edge of the path.
 - **Out** — Feathering is applied to the outside edge of the path.
 - **Both** — Feathering is applied to both sides of the path.
 - **None** — No feathering is applied.
7. Select the Feather % box and type a value in the box (or click the  to display a slider) to set the amount of feathering that is applied to the path.

Fine-tuning masks

Depending on the source material, creating a clean mask can be a tricky exercise. There are a few tools and tricks you can use to fine tune a mask.

- **Solo the track:** Click the Solo button () in the track list to isolate the masked track. This allows you to concentrate exclusively on the mask.
- **Toggle effects:** Turn individual plug-ins on and off to isolate effects in a plug-in chain. Keep in mind that the order of the plug-ins in the chain is important in determining the final composited output.
- **Isolate channels:** Isolate individual color channels in the Video Preview window by clicking the Overlays button (). Click the arrow on the button to select the specific channel to be isolated and whether to display this channel in grayscale only. Then click the main button to toggle the channel display on and off. The **Alpha as Grayscale** option isolates the alpha channel mask and displays it in grayscale. *For more information, see [Understanding the Video Preview window](#) on page 253.*



Using the Mask Generator

The Mask Generator is a plug-in that controls the transparency of events to be used as masks when you use events that are not grayscale. Apply the plug-in to an event (or a track) in the same way as any other plug-in: just drag-and-drop. The Mask Generator plug-in can be found in the Video FX window (from the **View** menu, choose **Video FX**).

 *The Mask Generator and parent/child video track grouping is only available in the full version of Vegas software.*

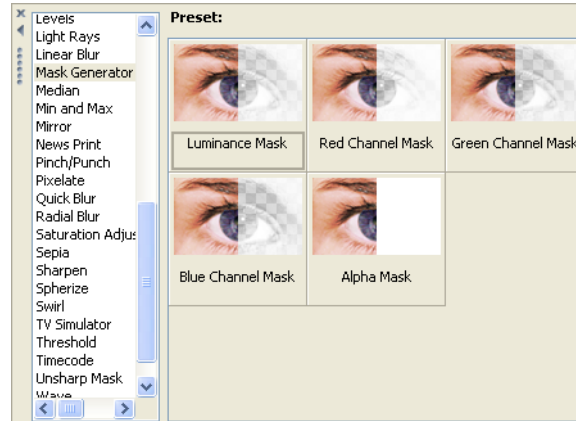

How the Mask Generator works

The following illustration demonstrates some of the effects of the Mask Generator. The background image is the original mask. There are five ellipses on the mask: white, red, green, blue and an invisible alpha channel. Note especially the checkered ellipse in the lower left of the mask; this is the alpha channel. You can base the alpha channel on a color or define the alpha channel in a graphics program that supports alpha channel creation. Masks with alpha channels must be saved in a format that supports this method of transparency, such as PNG or TGA. As in this example, the alpha channel may be invisible in the actual mask.

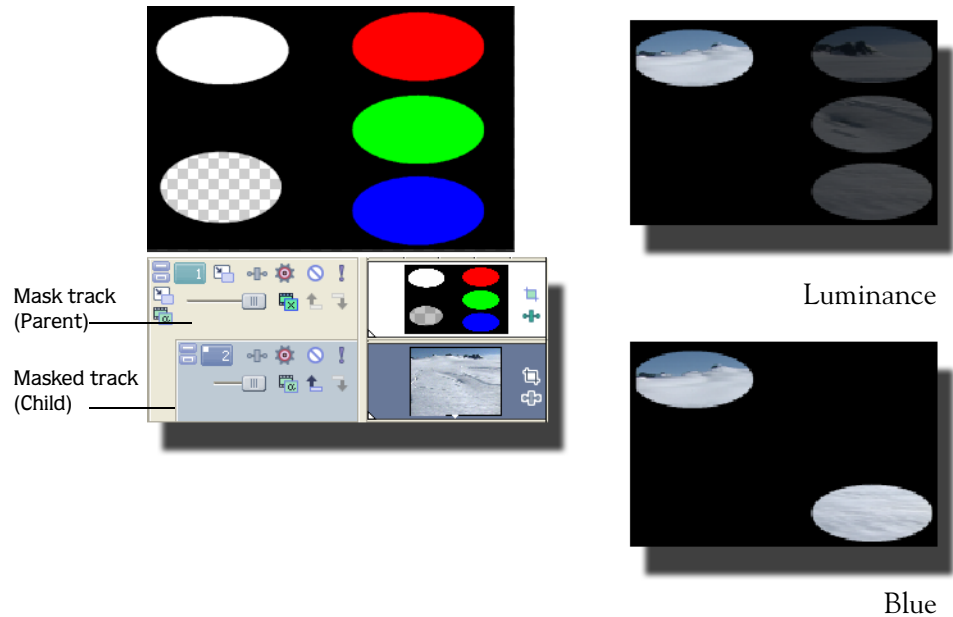

The top-right example uses luminance to determine the transparency in the mask. The white area is completely transparent. Since white is made up of 100% values of red, green, and blue (255,255, and 255), those three colors are all 33% transparent as well. In the lower-right example, blue is the selected transparent index. The blue area is 100% transparent and so are all areas that have a value of 255 for blue (0,0,255), including white (255,255,255).

Chroma keying

Chroma keying or bluescreening is a special case of overlay transparency. A color key is a specific color or a range of similar colors in an image that are made transparent, allowing a background video to show through. The idea is to take a video subject and film it against a solid, uniform background color. It is critical that the color be smooth and uniformly lit with no shadows, and that the color chosen for the background not be used in the subject.

The most important factors in successful blue screening happen during shooting, well before the footage is imported into Vegas software. Compression of the source video is also an important consideration. While almost all video is compressed in some way, highly compressed video does not key well because colors can be smeared together and edges tend to not be very sharp.

If your source footage is good and the captured video file is also of high quality, color keying is an easy process.

1. Insert a video with a blue (or any solid colored) background into a track. This is the overlay video.
2. Insert the background video that will show through the blue areas into the next lower track.

Note: *You do not need to set the lower track as a child track when using the Chroma Keyer plug-in as you would with a mask.*

3. Click the overlay video (foreground, higher track) to select it.
4. Drag a Chroma Keyer plug-in from the Video FX window onto the overlay video. The Video Event FX window displays.
5. Click the down arrow to the left of the Split Screen View button () on the Video Preview window and choose **FX Bypassed**. This will bypass the effect of the Chroma Keyer plug-in until you are ready to view the effect.

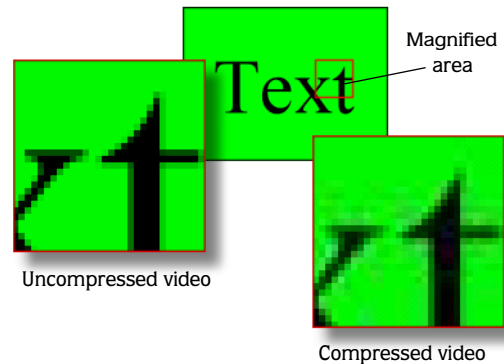

6. In the Video Event FX window, click the Eyedropper button (👉). The cursor changes to an eyedropper icon.
7. Draw (click and drag) a small rectangular selection area around the color(s) to key out. Although you can select the color range from just about anywhere, the Video Preview window is the best location.

Note: Other effects that can change the color of the event should be bypassed when using the Eyedropper tool.

8. Click the Split Screen View button (📺) on the Video Preview window to restore the video effects. The Video Preview window shows the result of the Chroma Keyer plug-in.

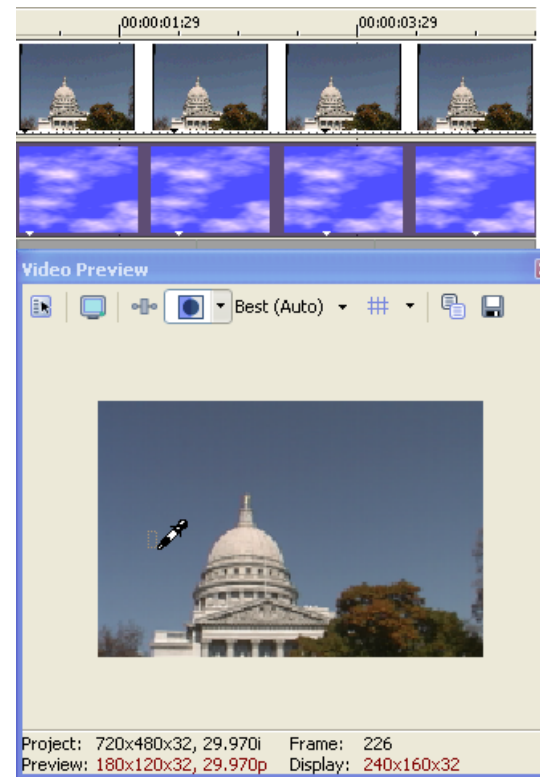

When a subject is filmed against a solid colored background in a studio, you can key out the background color using the Mask Generator or the Chroma Keyer plug-in. You can select a wider range of colors using the Chroma Keyer plug-in, making it the perfect tool for less-than-perfect blue screens.

This procedure selects a small range of colors to use as a key. In the example above, the blue sky around the dome is far from uniform and it would be difficult to key it out with a traditional blue screen key. The color is uniform enough, however, that a range of blues can be selected directly from the preview image. Use the controls at the bottom of the dialog box to determine the sensitivity of the colors selected. Since the filter selects a range of colors, it is a good idea to try to select a relatively small range of similar colors. Drawing a color selection area that spans both blue and red colors would make very large sections of an overlay transparent.

Tip: It is possible to use multiple Chroma Keyer plug-ins on a single event, keying out the blues with one and the reds with the other, without keying out any colors between blue and red.



Adding Video Transitions and Motion

Want something other than a cut or crossfade between video events? Vegas® software provides a wide variety of transitions you can add to your project. This chapter also covers track motion and keyframe animation, which allows you to automate video effects, media generators, cropping, panning, and more.

Understanding basic transitions

Transitions occur between two video events. Most professional productions, on television or on the big screen, use only two types of transitions. The first is a simple cut, where one scene immediately cuts to the other without delay or effects. The other is a fade, otherwise known as a crossfade or a dissolve.

Cuts

A cut is actually not a transition. Instead, the last frame from an event is immediately followed by the first frame of the next event. This is what happens with two adjacent events on the timeline, either in the same track or in different tracks. This can also happen when an event is punched into another (with fade edge edits turned off).

Adjacent events

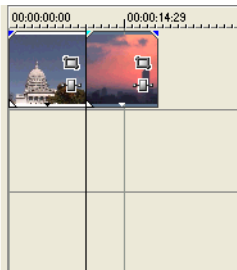

Events on different tracks

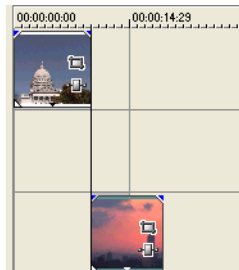

Punch-in events

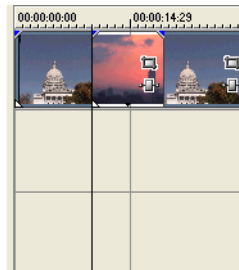

Crossfades

You can fade one event out and fade into the next event by simply overlapping the two. The duration of the transition is determined by the amount of overlap. *For more information, see [Crossfading events](#) on page 75.*

Using transition effects

Transition effects are more complex than a simple cut or crossfade. You can replace a crossfade with a transition and then customize the transition to meet your needs.

Adding a transition

1. Insert a video event onto the timeline.
2. Insert another event so that it overlaps the first to create an automatic crossfade.
3. In the Transitions window, browse for a transition effect. If the Transitions window is not visible, choose **Transitions** from the **View** menu.
4. Drag the effect onto the crossfade between the two events.

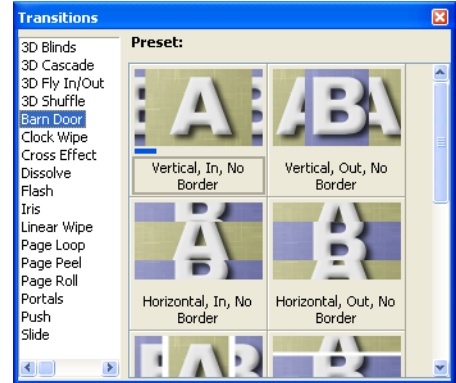

Note: The duration of a transition is automatically determined by the amount of overlap between the two events. As with other events, you can control the precise duration of a transition by dragging the edges in and out. You can also slide a transition for more precise control. For more information, see [Sliding a crossfade](#) on page 76.

The original crossfade...

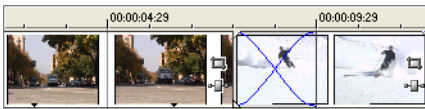

...and the new transition effect.

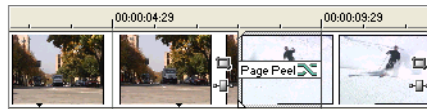

Tip: Some transitions also have their own shortcut keys. On the numeric keypad, press **[1]** to insert a crossfade, **[*]** to insert a dissolve, and **[-]** to insert a linear wipe. Hold **Ctrl** while pressing **[1]** to convert the transition to a cut at the cursor position.

Adding a transition to the end of an event

Typically, a transition occurs between two events on a track, but you can also use transitions to fade to and from the background, whether that is an underlying image, video, or background color. For example, you can drag a Clock Wipe transition to the end of a video event and have the wipe go from the video event to black.

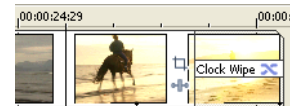

Adding a transition to all selected events

If you tend to use the same transitions often, you can save yourself some time by adding a transition to all selected events at once.

1. Select the events where you want to add the transition.
2. From the **View** menu, choose **Transitions** to display the Transitions window.
3. Select a transition from the list on the left side of the window. The thumbnail images on the right side of the window represent each of the existing presets for the selected transition. Hover your cursor over a preset to see an animated example.
4. After you've found the setting that you want to use, drag it to the position where you want it to occur on the timeline.
5. The Video Event FX dialog is displayed to allow you to edit the transitions settings, and a  is displayed in the timeline to show you where the transition takes place. You can also click this icon to edit the transition's settings.



Dropping on existing cuts, crossfades, or transitions

- If you drop the preset on an existing transition, only transitions within the selection will be changed. Cuts and crossfades are preserved.
- If you drop the preset on an existing crossfade, only crossfades and transitions within the selection will be changed. Cuts are preserved.
- If you drop the preset on an existing cut, all cuts, crossfades, and transitions within the selection will be changed.

Dropping on event edges

- If you drop the preset on a transition that is at the beginning or end of an event (but does not span two events), only single-event transitions that occur on the same end of the event within the selection will be changed.
- If you drop the preset on an event fade-in or -out, event fade-ins/outs and single-event transitions that occur on the same end of the event within the selection will be changed.
- If you drop the preset on an event edge with no fade, all other event edges, event fade-ins/outs, and single-event transitions that occur on the same end of the event within the selection will be changed.

Note: To change the length of the transition for cuts that are converted to transitions, use the *Cut-to-overlap conversion settings* on the *Editing* tab of the *Preferences* dialog.

Adding a transition progress envelope

Normally, a transition progresses from 0 to 100% in a linear fashion over the length of the transition. A transition progress envelope gives you complete control over a transition: you can hold, reverse, and repeat individual transitions.

1. Right-click a transition.
2. From the shortcut menu, choose **Insert/Remove Envelopes**, and then choose **Transition Progress** from the submenu. An envelope is added to your transition.

3. Add points and adjust the fade curves as desired. For more information, see [Using the Envelope Edit tool](#) on page 128.

In the following example, the transition starts, progresses to 50%, reverses direction, and then finishes.

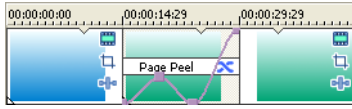

Understanding track layers

If you want, you can view and modify transitions in an A/B roll mode. Right-click the track header and choose **Expand Track Layers** from the shortcut menu to expand the track to reveal three layers within the main track. These layers are called the A roll, the B roll, and the transition roll.

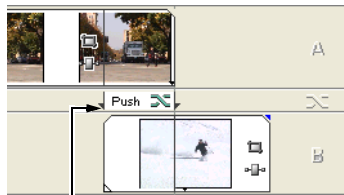
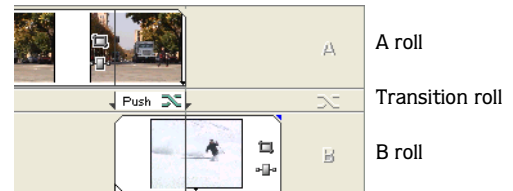

Transition direction arrow

The concept of an A/B roll is fundamentally different from the multitrack philosophy. Every track is in some way mixed (composited) into the final output in a multitrack system, but events are not mixed on the A/B roll. Instead, either the A roll or the B roll is playing, with the two trading places during a transition. You could mix the two for as long as you want with a transition, but they do not blend without an intervening transition. Transitions move **from** one roll and **into** the other. This could be from A to B or from B to A. The direction of the transition is automatically set. The small arrows on the side of the transition event indicate this direction.

As the sequence at the right shows, the video output can shift from the A to the B and back to A many times during a production, but there is only one video output from any particular roll at a time. This means that the A and B rolls are not composited.

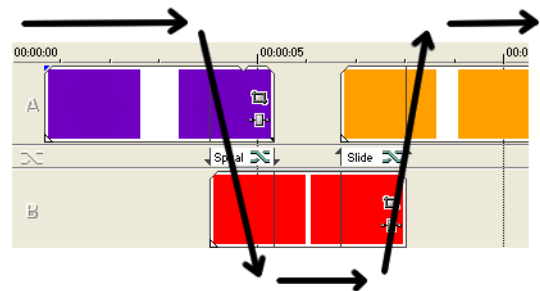

Converting a cut to a transition

The transition between two events that are adjacent to each other on the same track is instantaneous and is called a cut. However, if the first event is trimmed back from the end and the second event is trimmed back from the beginning (in other words, both have enough media to overlap), you can transform the cut into a transition effect using this extra media.

1. Right-click the line between two adjacent events at the cut position.
2. From the shortcut menu, choose **Transition** and then choose the transition that you want to insert (e.g., **Insert Sony Iris**).

You can also drag a transition to the cut from the **Transitions** window.

The duration of the newly inserted transition event is determined by the Cut-to-overlap conversion time set in the Editing tab of the Preferences dialog. To access this dialog, choose **Preferences** from the **Options** menu.

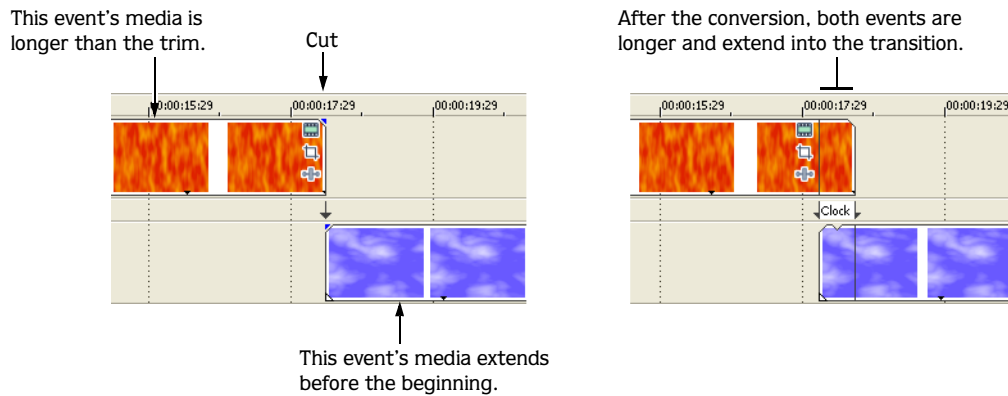

Note: There must be enough media in the respective events to cover the transition (e.g., the end of the first event must not be the end of the media file).

Tip: You can also convert cuts between audio events to crossfades. Click the cut and press **[7]** on the numeric keypad to create a crossfade. There must be enough media on either side of the cut to create the crossfade.

Converting a crossfade or transition to a cut

1. Click to position the cursor within the transition.
2. Hold **Ctrl** while pressing the **[7]** key on your numeric keypad.

The transition will convert to a cut, using the Cut-to-overlap conversion settings on the Editing tab of the Preferences dialog to determine where the cut occurs.

Previewing a transition

The easiest way to preview a transition is to set the loop region to the duration of the transition and then loop the playback. This allows you to adjust the transition while it is playing and make changes in real time.

1. Double-click the transition. This automatically creates a time selection equal to the length of the transition.
2. Click the Loop Playback button (🔁) to turn loop playback on. The selection area bar is dark blue when loop playback is turned on.
3. Click the Play button (▶).

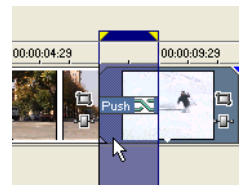

To preview complicated transitions, you may want to build a dynamic RAM preview or prerender the effect. For more information, see [Building dynamic RAM previews](#) on page 256 or [Prerendering video](#) on page 255.

Modifying a transition

All of the transitions include several presets that create standard transitions. If a preset doesn't meet your needs, you can customize a transition to suit your taste.

Tip: You can also animate the parameters of a transition with keyframes. For more information, see [Using keyframe animation](#) on page 237.

1. Click the Transition Properties button (⌘) on the transition or right-click the transition and choose **Transition Properties** from the shortcut menu. The Video Event FX window appears.
2. Change the parameters. Changes update in real time in the Video Preview window. For help on the different controls in the Video FX window, click the Plug-In Help button (⌘) to access online help.

Saving custom settings as a preset

After you modify a transition, you can save your settings as a preset for use at a later time. You can apply presets by choosing them from the Preset drop-down list.

1. Modify the settings in the window to create your desired transition effect. For help on the different controls in the window, click the Plug-In Help button (⌘) to access online help.
2. Click the name in the Preset drop-down list. The current text is highlighted.
3. Enter a name for the new preset.
4. Click the Save Preset button (⌘).

You can save any additional changes to the custom preset by clicking the Save Preset button.

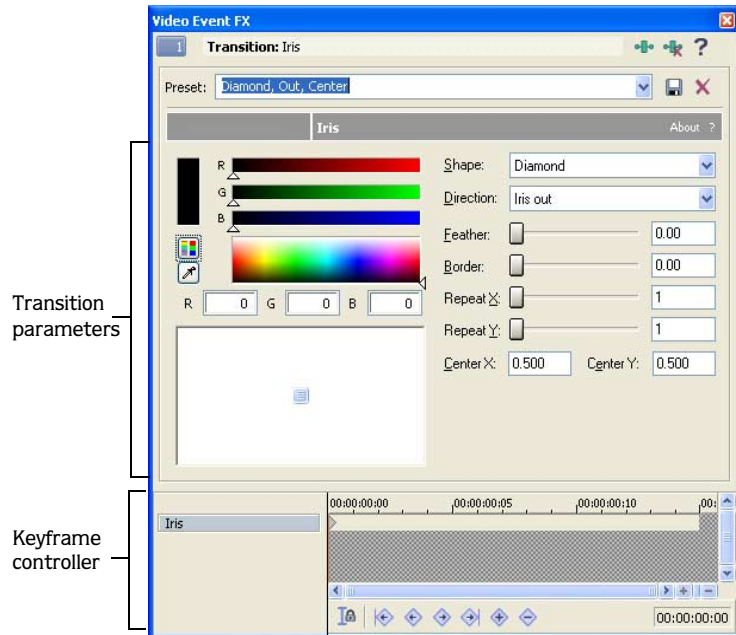

Using keyframe animation

Keyframe animation is a technique that computer artists use to quickly make complex animated sequences. Instead of drawing every frame of a title scrolling in from top to bottom by hand, an animator simply has to set a starting and ending position for the animation and let the computer interpolate the intermediate frames. The animation pictured on the right has three keyframes: a starting, middle, and ending keyframe. More complex animations use more keyframes.

While keyframing motion may be the most obvious use for keyframe animations, just about any parameter of an effect can be animated with keyframes. Keyframe animation techniques are used in many areas, including transition effects, video effects, event panning and cropping, generated media, and track motion. You can animate color, brightness, transparency, motion, size, perspective, and many other parameters with keyframes.

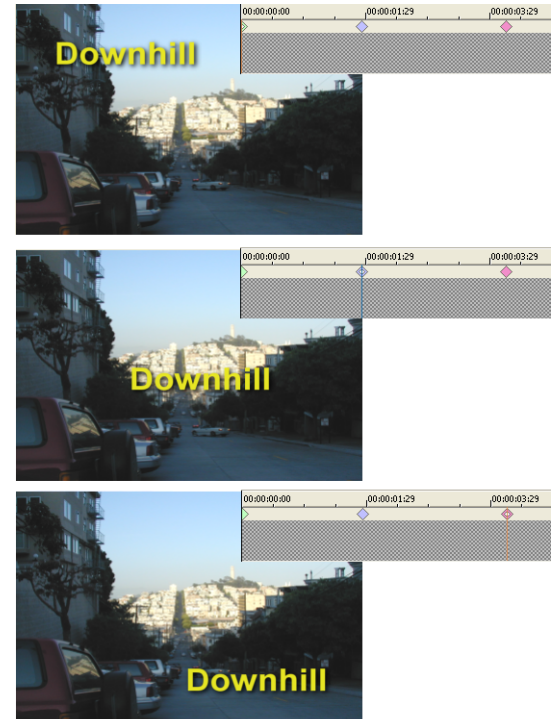

These three frames show the progression of a title across three keyframes.

Understanding the keyframe controller

The keyframe controller appears at the bottom of the Video FX window (used for transitions, effects, and generated media), the Track Motion window, and the Event Pan/Crop window.

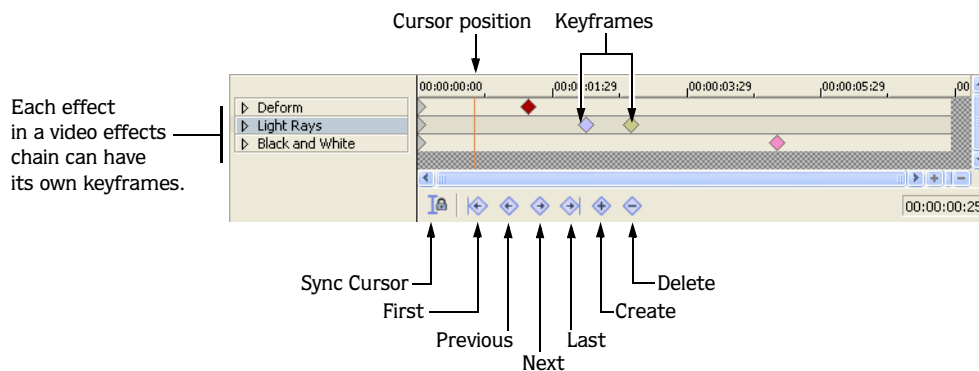

The cursor position is marked by a flashing line on the controller. This position can also be automatically updated on the timeline, with the Video Preview window also updating in real time to reflect changes. Click the Sync Cursor button () on the keyframe controller to sync the keyframe cursor with the timeline cursor.

Adding keyframes

Every effect has a starting keyframe at the beginning (left side) of the keyframe controller. This sets the initial parameters for the effect. In order to animate the effect, you must add another keyframe to the effect and change some of the parameters. When you first add a new keyframe, it has the same settings (for the transition, effect, pan/crop, etc.) as the first keyframe. You can then modify the settings of the new keyframe to create the animation from the first keyframe settings to the second.

1. Click the keyframe controller timeline to move the cursor where you want to add a keyframe. The current position is marked by a blinking cursor.
2. Click the Create Keyframe button ()
3. Modify the settings in the window for the new keyframe as desired.

Tip: You can also add a new keyframe by positioning the cursor in the keyframe controller and changing any parameters in the window. A keyframe is added with the new settings at the cursor position.

Deleting keyframes

1. Select a keyframe in the keyframe controller.
2. Click the Delete Keyframe button ()

Navigating in the keyframe controller

Use the keyframe navigation buttons (First, Previous, Next, and Last) to quickly jump to a keyframe. Alternately, press **Ctrl**+**←** or **Ctrl**+**→** to move to the previous or next keyframe.

Modifying keyframes

After you create your keyframes, you can move them, copy and paste them, and change the interpolation curves between them.

Moving keyframes

You can move a keyframe within the keyframe controller by dragging it to a new position. For track-level keyframes, you can also move the keyframes in the track view. For more information, see [Working with keyframes in track view](#) on page 240.

Copying and pasting keyframes

Keyframes on the controller can be copied, pasted, and duplicated.

1. Right-click a keyframe.
2. From the shortcut menu, choose **Copy**.
3. Right-click the keyframe controller at the position where you want to paste the keyframe.
4. From the shortcut menu, choose **Paste**.

Duplicating keyframes

1. Right-click and drag a keyframe to a new position.
2. From the shortcut menu, choose **Copy**. A duplicate keyframe is created at the new position.

You can also duplicate a keyframe by holding the **Ctrl** key while dragging it.

Changing the interpolation curve

The interpolation curve determines the rate at which Vegas software animates between two keyframe settings. You can right-click a keyframe to choose a different shape for the interpolation curve. The shortcut menu provides six options: **Linear**, **Fast**, **Slow**, **Smooth**, **Sharp**, and **Hold**. Selecting **Hold** from the shortcut menu prevents any animation from being interpolated between two keyframes. The color of the keyframe indicates which interpolation curve is being used.

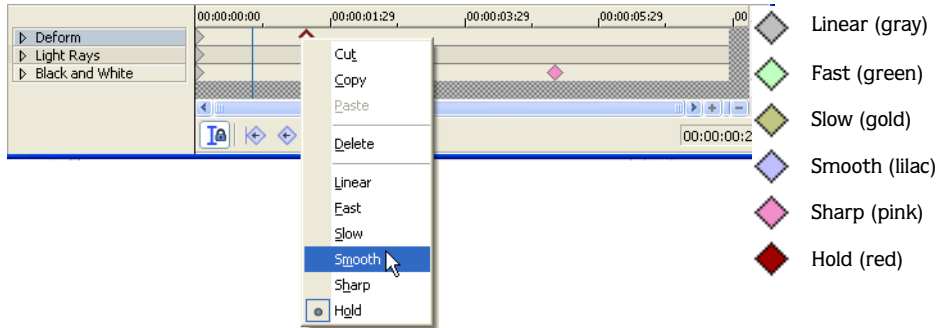

Changing the relative spacing of keyframes

You can change the relative positions of the keyframes as a group. This can be useful if you need to change the overall length of an animated sequence or if you need to copy a set of keyframes to another event that has a different duration than the original.

1. Click on the first keyframe, hold the **[Shift]** key, and click on the last keyframe in the sequence to select all of the keyframes.
2. Hold **[Alt]** and drag the first or last keyframe to scale the keyframes.

When copying keyframes from longer events to shorter events, you must temporarily lengthen the duration of the shorter event so that all of the keyframes appear on the keyframe controller. Once you have pasted the keyframes, you can rescale the keyframes using the above procedure, and then resize the event to its original length.

Working with keyframes in track view

You can move and modify track keyframes in track view. These keyframes are used in the following three track-level effects:

- Track effects plug-in (pg. 206)
- Track motion (pg. 245)
- Mask generator plug-in on a parent compositing track (pg. 226)

Viewing and moving track keyframes

Once you have added keyframes to one of these track-level effects, the track keyframes appear at the bottom of the track on the timeline. Click the Expand Track Keyframes button (⏏) to view the keyframes.

You can drag a keyframe on the track in the same way you would in the keyframe controller. To move several keyframes at once, use the Envelope Edit tool (⌘) to select and drag multiple keyframes.

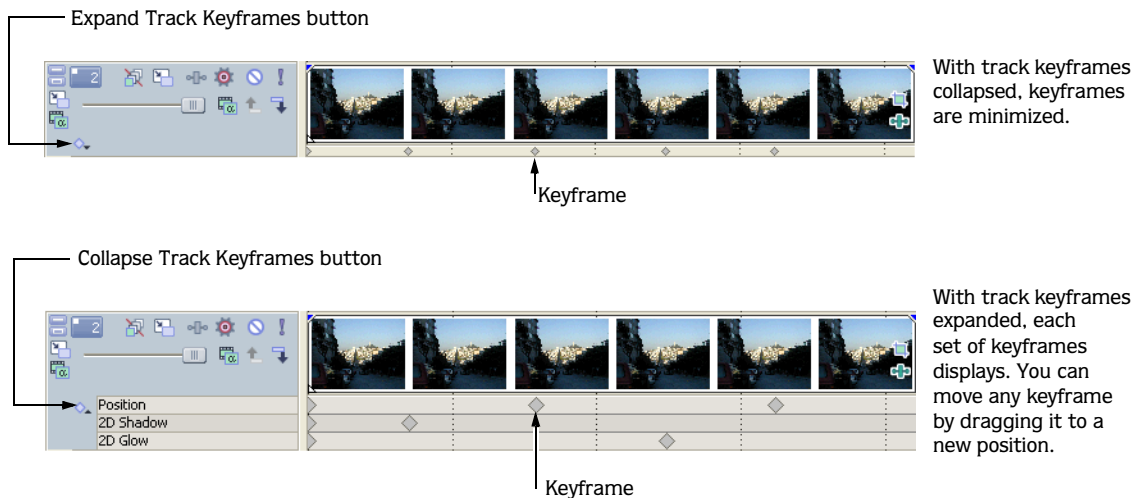

Tip: You can use ripple editing to automatically move track keyframes as you edit in the timeline. For more information, see [Applying post-edit ripples](#) on page 73.

Adding new track keyframes

You can add new track keyframes to an existing track-level effect by double-clicking the track keyframe area.

Editing track keyframes

Double-click a track keyframe to open the associated window and adjust the settings. To change a keyframe interpolation curve, right-click the keyframe and choose a curve type from the shortcut menu.

Locking track keyframes to events

When track keyframes are locked, you can move events along the track and the keyframes move along with them. Only keyframes that occur within the selected events move.

Select the Lock Envelopes to Events button (⏏) to lock track keyframes to the events on the track.

Hiding track keyframes

If track view becomes too cluttered, you can hide track keyframes from view. From the **View** menu, choose Show Video Envelopes, and choose Track Keyframes from the submenu to hide track keyframes.

Sample uses for keyframe animation





The following section provides several examples of how keyframe animation can be used with features such as event panning and cropping, video effects plug-ins, and generated text events.

Animating event panning and cropping

You can combine event panning and cropping tools with keyframe animation to create several special effects. *For more information, see [Cropping video](#) on page 187.*

Zooming in on a still image

By using keyframe animation in the Event Pan/Crop window, you can zoom in and out on a still image. In this example, four keyframes are used to zoom in on faces in an old photograph and zoom back out again. A generated color gradient event masks the edges of the image during the zoom to enhance the effect. *For more information, see [Using generated media](#) on page 211.*

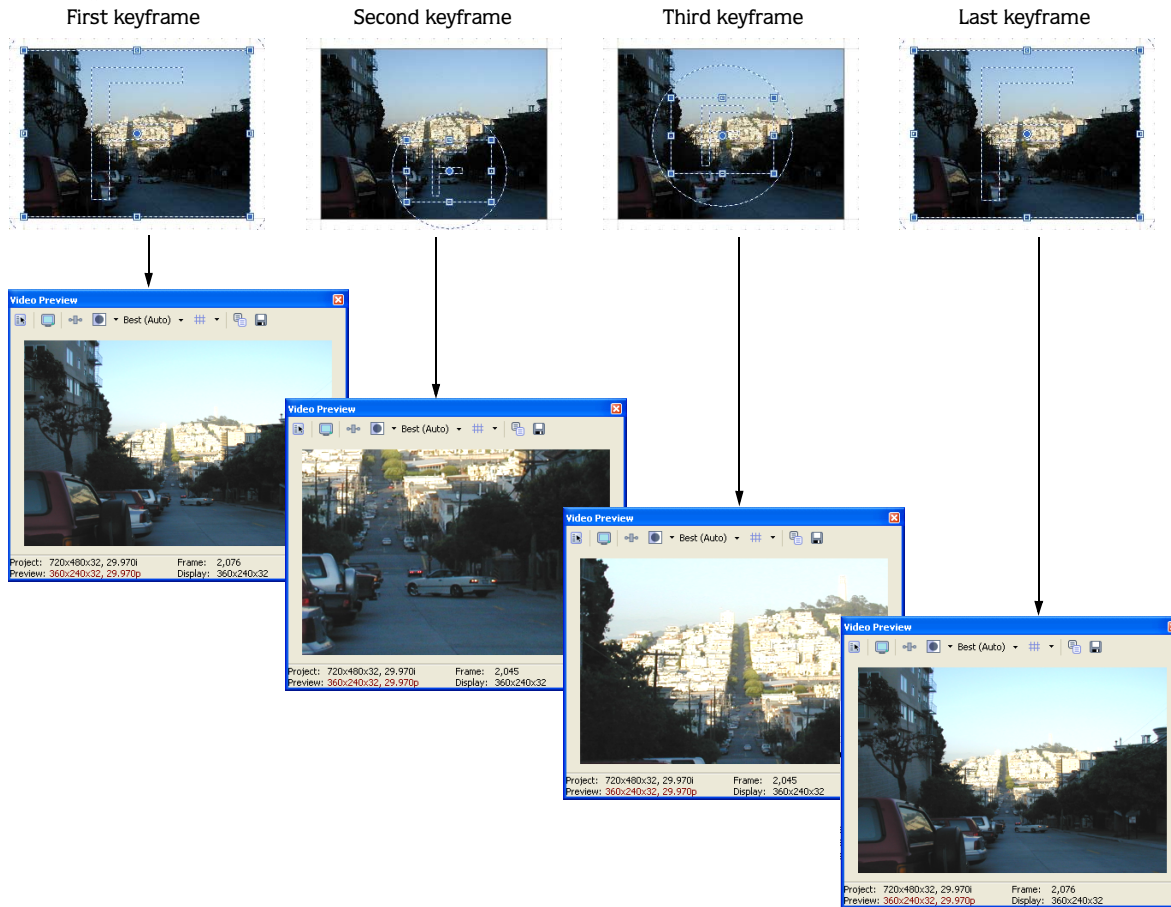

1. Click the Event Pan/Crop button () on the still image event.
2. Click the keyframe controller to position the cursor for the second keyframe.
3. Click the Add Keyframe button (). Resize and move the selection area to zoom in on a portion of the image.
4. Click the keyframe controller to position the cursor for the third keyframe.
5. Click the Add Keyframe button (). Resize and move the selection area to zoom in on a different portion of the image.
6. Click in the keyframe controller near the end of the event to place the final keyframe.
7. Click the Add Keyframe button ().
8. Right-click in the selection area and choose **Restore** from the shortcut menu. The selection area is zoomed out to include the full image for the last keyframe.

9. Preview the event in the Video Preview window. Adjust the settings in the Event Pan/Crop window as you preview the zoom effect.



Using pan-and-scan

Another way to use keyframe animation in the Event Pan/Crop window is panning, or pan-and-scan. Pan-and-scan is a technique commonly used when film is converted for television. Movie screens and film are usually wider (~2.35:1) than television (~1.33:1). When you transfer the film to video, you have four choices: (1) squash the film horizontally to fit, distorting it in the process; (2) crop it, possibly losing information on the sides; (3) letter box it so the top and bottom have black areas and the picture is shorter overall; and (4) pan-and-scan. Pan-and-scan is a variation of cropping, where someone goes through the movie and moves the crop area back and forth to follow the action or subject.

1. Click the Event Pan/Crop button () on the event. The Event Pan/Crop window appears.
2. Confirm that the Stretch to fill frame check box is selected.
3. Right-click the selection area and choose Match Output Aspect from the shortcut menu.
4. Select a starting position, size, and angle of rotation for the crop rectangle. This is the start position (first keyframe).
5. Click in the keyframe controller and press **Ctrl** + **End**. This moves the cursor to the end of the event.
6. Click the Create Keyframe button (). A new keyframe appears in the keyframe controller at the end of the event.
7. Change the position, size, and angle of rotation. This is the final position (last keyframe).

8. Preview the event. Add and adjust keyframes as needed to create the desired effect. You can adjust both temporal and spatial interpolation for each keyframe:
 - **Temporal interpolation** (how the pan occurs over time) is controlled by the keyframe interpolation curve type. Experiment with temporal interpolation by right-clicking a keyframe to change the interpolation curve type (hold, linear, fast, slow, smooth) and previewing the result. *For more information, see [Changing the interpolation curve](#) on page 239.*
 - **Spatial interpolation** (how the pan occurs within the video image) is controlled by the Smoothness setting of each keyframe. If you have three or more keyframes, the blue arc in the window shows the path of the center of the frame during the panning. A smoothness value of 0 makes the movement linear from one keyframe to the next. A higher smoothness value makes the path of the pan more curved. Select a keyframe and change the Smoothness value to adjust spatial interpolation.

Animating video effects plug-ins

You can use keyframe animation to smoothly and gradually apply an effect to an event. This example uses the Add Noise plug-in. The Add Noise plug-in adds static or noise to a video sequence. When added to a simple solid-colored background with a monochrome setting and animated, a pattern is produced that is similar to a television that is not tuned to any station.

1. Add an Add Noise plug-in to an event. *For more information, see [Adding a video effects plug-in](#) on page 206.* The Video FX window appears with the keyframe controller at the bottom of the window.
2. Add two keyframes to the event for a total of three including the one at the beginning. New keyframe attributes are copied from the previous keyframe.
3. Click the first keyframe to select it. Drag the Noise level slider to 0.
4. Click the last keyframe to select it. Drag the Noise level slider to 0.
5. Click the second keyframe to select it. From the Preset drop-down list, select Grainy.
6. Hold **[Ctrl]** and drag the second keyframe to duplicate it. Position this new keyframe between the second and final keyframes.

The effect is off at the first keyframe and smoothly transitions to a grainy effect at the second keyframe, at which point the effect remains constant until the third keyframe. Then the effect gradually fades out until it reaches a minimum value at the last keyframe.



The results of gradually transitioning into an effect using keyframe animation.

Animating generated text

You can add a generated text event to a project by dragging a text generator from the Media Generator window. For more information, see [Using generated media](#) on page 211. You can then animate the text by adding keyframes.

Not all attributes of generated text media can be animated using keyframes, however. You cannot, for example, morph one text message into a different one. Some aspects can be easily and smoothly animated using the keyframe controller, such as text, color, transparency, leading, tracking, and position.

Other aspects of generated text do not allow interpolated keyframe animation. For example, if you set the text to “One” initially and then at five seconds change it to “Two”, the text will suddenly jump to the new value at the five second keyframe. This behavior is different from the behavior of other keyframe animation techniques.

In this example, keyframes are used to make a title appear one letter at a time across the screen.

1. Drag a text generator from the Media Generator window to the timeline.
2. Right-click the new event and choose **Edit Generated Media**.
3. Enter the first letter of the title, for example “T”.
4. Click the keyframe controller at the 1.000 second mark and enter the second letter, for example “y”. The title now reads “Ty”. A new keyframe appears in the keyframe controller at the 1.000 second mark.
5. Proceed down the keyframe controller to 2.000 and enter the letter “p”.
6. Proceed down the keyframe controller repeating this process until the title is finished: “Typing”.
7. Preview the event in the Video Preview window. The word “Typing” appears one letter per second until finished.

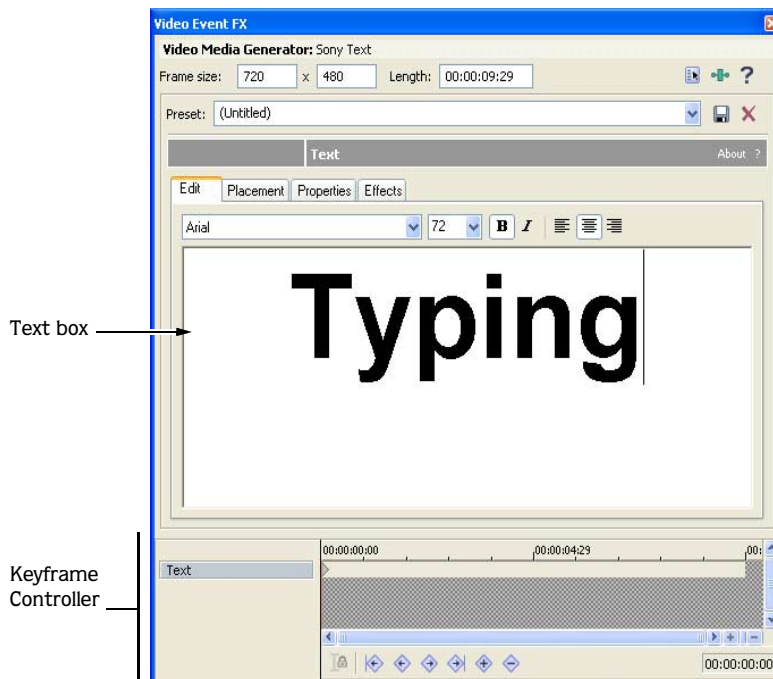

Adding track motion

The Track Motion window (accessible by clicking the Track Motion button  on any video track) is used to move a video track across a background. This background can be a solid color, another video event, or an image. Picture-in-picture effects and scrolling title sequences are two simple cases where this tool is important.

The gray area in the center of the window (covered by the blue/gray rectangle) represents the actual screen or area that is visible in the movie. The area outside of the main screen, which is filled with dotted lines, is the general workspace. The video you are moving can be positioned off of the visible screen and then animated onto and across the screen. The dots are markers to help position the video window. If snapping is enabled, these serve as snapping points.

The main window allows you to control the placement, size, and orientation of the overlay video through time. The blue and gray rectangular overlay in the middle represents the video on the track. The selection box in the workspace is used to represent the orientation of the track.

You can also use 3D compositing to move tracks through space. *For more information, see [3D Compositing](#) on page 216.*

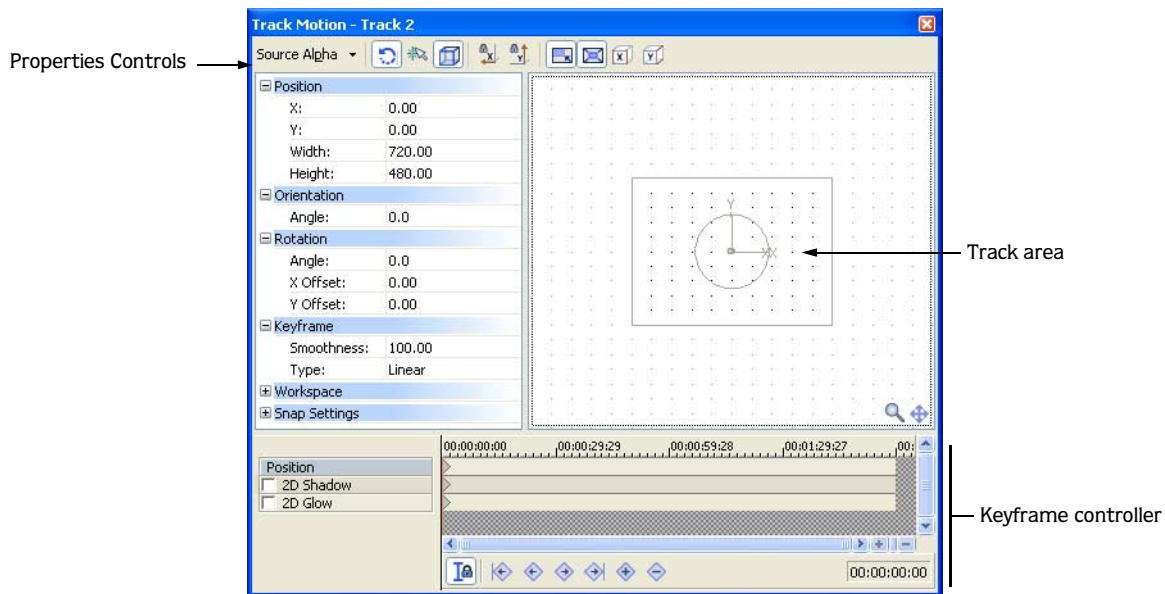

Controlling track motion

1. Click the Track Motion button () on the track that contains the overlay that you want to animate. The Track Motion window is displayed.
2. Adjust the selection area to change the viewable area of the track and its position in space. Guides are displayed in bold to indicate how the track will be moved or rotated:

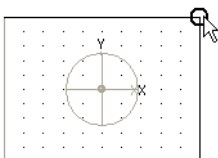

Moving closer to or farther from viewer. Drag across corners to flip the track.

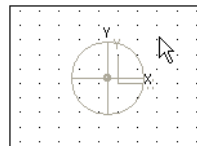

Dragging the track.

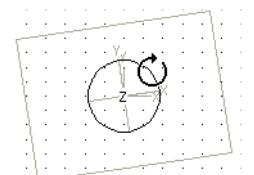

Rotating counterclockwise around the Z axis.

3. Use the buttons at the top of the dialog to allow or prevent movement or scaling. *For more information, see [Changing editing options](#) on page 246.*
4. The track motion occurs instantly, and the results are updated in the Video Preview window.
5. Use the keyframe controller at the bottom of the Track Motion window to establish distinct track motion settings throughout the duration of the track.

During playback, immediate frames are interpolated to create smooth motion. Expand the Keyframe interpolation heading on the left side of the window and drag the Smoothness slider to adjust the interpolation. *For more information, see [Using keyframe animation](#) on page 237.*

Using the track motion shortcut menu

When you right-click anywhere in the Track Motion window, a shortcut menu appears:

- **Restore View** returns the workspace display to its original state.
- **Restore Box** returns the overlay to its original state (size, rotation, and position).
- **Restore Rotation** returns the overlay to its unrotated state.
- **Restore Size** returns the overlay to its original size.
- **Restore Center** moves the overlay to the center of the frame.
- **Flip Horizontal** flips the overlay backwards or left to right.
- **Flip Vertical** flips the overlay upside-down.
- **Match Output Aspect** sets the aspect ratio to the frame value.
- **Make Square Aspect** sets selection box to a square aspect.

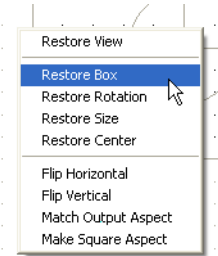

Changing editing options

Use the toolbar at the top of the Track Motion window to change your editing options.

Icon	Command	Description
	Enable Rotation	Select this button if you want to be able to rotate, or spin, the video. When the button is not selected, video is locked so you can move it horizontally or vertically, but the track cannot be rotated.
	Enable Snapping to Grid	Select this button if you want your editing to snap to the grid.
	Edit in Object Space	Select this button if you want to edit in the object's space rather than the camera's space. For example, if a track is rotated, its X axis may not correspond to the X axis of the of the Video Preview window. Selecting the Edit in Object Space button in conjunction with the Prevent Movement buttons allows you to move the object along its own X and Y axes.
	Prevent Movement (X)	Select this button if you want to prevent horizontal movement of the track.
	Prevent Movement (Y)	Select this button if you want to prevent vertical movement of the track.
	Lock Aspect Ratio	Select this button if you want the selection box to retain its aspect ratio during resizing. When the button is not selected, the height and width can be resized independently.
	Scale About Center	Select this button if you want the selection box to retain its center point when you resize the box by dragging its edges. When the button is not selected, the opposite side of the selection box will remain anchored when you drag the edges to resize it.
	Prevent Scaling (X)	Select this button if you want to lock the horizontal dimension of the selection box.
	Prevent Scaling (Y)	Select this button if you want to lock the vertical dimension of the selection box.

Using keyframes in track motion

Keyframes are what create the motion in the track motion feature. You can create, modify, and remove keyframes in the keyframe controller in the same way as with any other feature that uses keyframes. *For more information, see [Using keyframe animation](#) on page 237.*

The keyframe controller in the Track Motion window has three attributes that can be animated: position, shadow, and glow. Each effect can be animated independently. The shadow and glow effects can be turned on and off. Each effect has its own set of controls that appear on the left-hand side of the window. You can access these controls by clicking the respective item on the keyframe controller.

Tip: *If any controls described in this section are not visible on the screen, enlarge the Track Motion window by dragging the lower right corner until all controls are revealed.*

Position	
X:	-97.30
Y:	-11.06
Width:	720.00
Height:	480.00
Orientation	
Angle:	-32.1
Rotation	
Angle:	0.0
X Offset:	0.00
Y Offset:	0.00
Keyframe	
Smoothness:	100.00
Type:	Linear
Workspace	
Zoom (%):	50.00
X Offset:	396.00
Y Offset:	5,148.00
Snap Settings	
Grid Spacing:	40
Rotation:	15

Position

You can control the position of the overlay in the main window by dragging the selection box or editing the controls on the left side of the window. However, the Position, Orientation, and Rotation controls in the window are invaluable when you need precision in resizing, moving, or rotating the overlay.

The Smoothness box allows you to modify the smoothness of the interpolation curve among three or more keyframes.

You can use the Workspace controls to adjust the magnification and viewable area of the workspace. Use the Snap Settings controls to adjust the grid in the workspace.

2D Shadow

This creates a simple drop shadow that appears under the entire window or only under the opaque (nontransparent) parts of the overlay. You can control the size and offset of the shadow as well as the shadow color. A shadow is especially effective under a picture-in-picture window or to emphasize text and titles. Use the Eyedropper tool to select a specific color from anywhere on the screen.

The shadow effect creates a drop shadow under an object, window, or title. A shadow is especially effective under a picture-in-picture window.

1. Select the 2D Shadow row in the keyframe controller. When the 2D Shadow row is selected, shadow controls are displayed in the Track Motion dialog.

Select the 2D Shadow check box to apply the shadow so you can see the results of your shadow in the Video Preview window, or clear the check box to bypass the shadow.



2. Use the 2D Shadow controls on the left side of the window to set the color and appearance of the shadow:
 - Blur % — type a number in the box or click the button to display a slider you can use to soften the edge of the shadow. Set to 0 for a hard edge, or increase the setting to feather the edge of the shadow.

- Intensity — type a number in the box or click the button to display a slider you can use to establish the transparency of the shadow's blurred edge. Decrease the setting for a translucent shadow, or increase the setting for a more opaque shadow.
 - Color — click the down arrow next to the color swatch to display a color picker. Use the sliders or edit boxes in the color picker to set the shadow color, or use the eyedropper tool () to sample a color from your screen.
3. Adjust the size position of the shadow by dragging the box in the workspace or using the Position, Orientation, and Rotation controls on the left side of the window. For more information about manipulating the selection box, see [Controlling track motion on page 245](#).

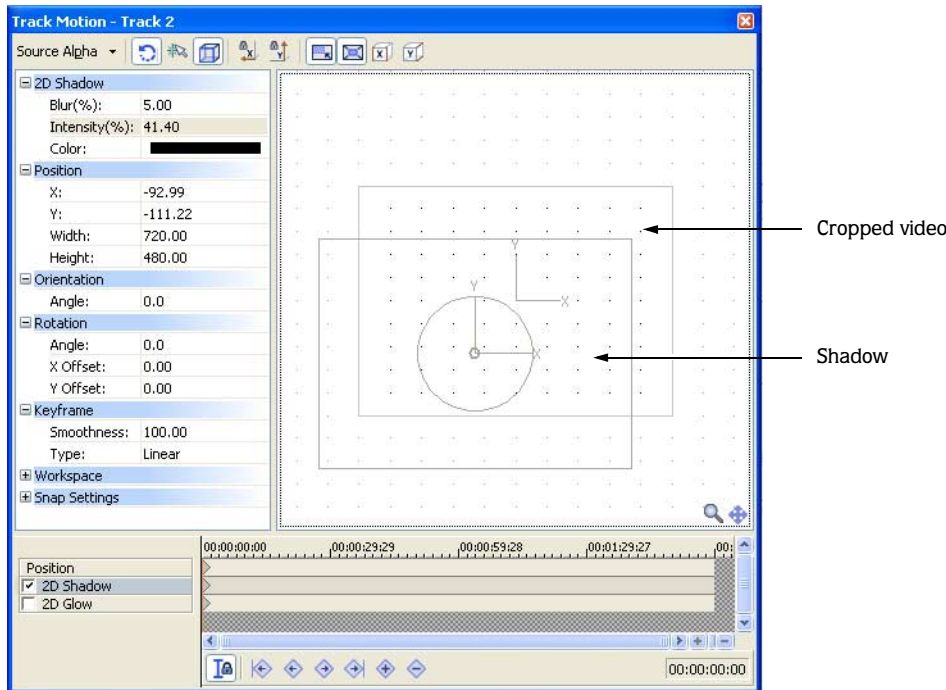

4. To animate the shadow, click in the 2D Shadow row of the Keyframe Controller to set the cursor to a later time and adjust the shadow settings.



2D Glow

Glow is a bright haze surrounding an overlay. In general, light colors are used for glow effects, but you can emphasize bright text on complex backgrounds by using a very small black glow, with little or no feathering, and 100% intensity.

1. Select the 2D Glow row in the keyframe controller. When the 2D Glow row is selected, glow controls are displayed in the Track Motion dialog.

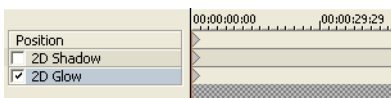
Select the 2D Glow check box to apply the glow so you can see the results of your shadow in the Video Preview window, or clear the check box to bypass the glow.



2. Use the 2D Glow controls on the left side of the window to set the color and appearance of the glow:
 - Blur % — type a number in the box or click the  button to display a slider you can use to soften the edge of the glow effect. Set to 0 for a hard edge, or increase the setting to feather the edge of the glow.
 - Intensity — type a number in the box or click the  button to display a slider you can use to establish the transparency of the glow's blurred edge. Decrease the setting for a translucent glow, or increase the setting for a more opaque glow.
 - Color — click the down arrow next to the color swatch to display a color picker. Use the sliders or edit boxes in the color picker to set the glow color, or use the eyedropper tool () to sample a color from your screen.
3. Adjust the size position of the glow by dragging the box in the workspace or using the Position, Orientation, and Rotation controls on the left side of the window. For more information about manipulating the selection box, see [Controlling track motion](#) on page 245.

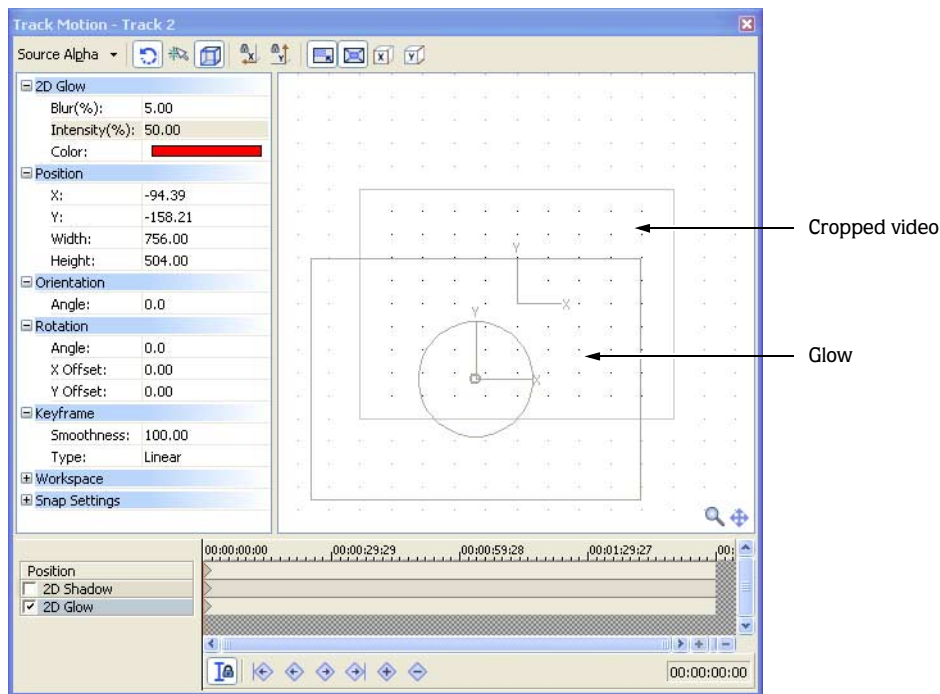

4. To animate the glow, click in the 2D Glow row of the Keyframe Controller to set the cursor to a later time and adjust the glow settings.

Creating a picture-in-picture effect

Picture-in-picture is an easy effect to reproduce using track motion.

1. Insert the background video into a track.
2. Insert the overlay video into another track just above the background video track.
3. Click the Track Motion button (Ⓜ) on the upper overlay track.
4. In the Track Motion window, position and resize the track area.

The illustration below shows some of the relevant parts of this procedure. Note the shadow cast by the overlay video. This is added by selecting the 2D Shadow check box on the keyframe controller. The Video Preview window displays the results.

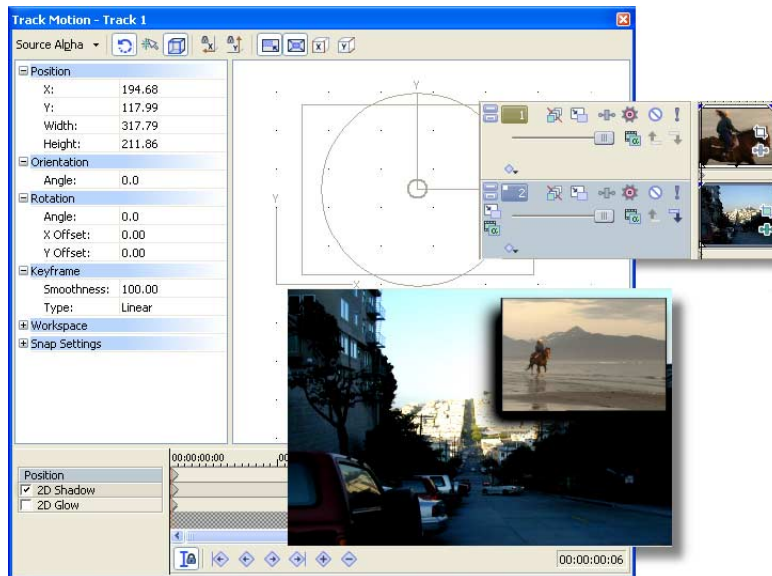

Tip: While overlay picture-in-picture windows are often completely opaque, you can fade them in and out using opacity envelopes. For more information, see [Using opacity envelopes](#) on page 139.

Animating the overlay

You can animate many aspects of an overlay using the keyframes at the bottom of the Track Motion window.

1. Insert a video event onto the timeline.
2. Click the Track Motion button (Ⓜ) in the track list.
3. In the Track Motion window, resize the overlay by dragging the handles at the edges of the overlay.
4. Drag the middle of the overlay to position it. This will be the size and position for the start of the animation.

5. Click the timeline of the keyframe controller at a later time to move the cursor to that position.

Tip: With the Sync Cursor button () enabled, you can also navigate to a new position on the main timeline. The cursor is automatically moved on the keyframe controller to the same location.

6. Reposition the overlay. A new keyframe is automatically added to the keyframe controller at the new cursor position.

When you preview the video, the position of the overlay interpolates between the two keyframes with a smooth animation.



Previewing and Analyzing Video

As you work in Vegas® software, you can preview your video by using the Video Preview window or by connecting to an external monitor. You can optimize previews by adjusting preview quality, prerendering video, or building a dynamic RAM preview. The Video Preview window also provides features such as safe area overlays, grid overlays, and isolated color channel displays to further enhance your productivity.

 *Dynamic RAM previews are only available in the full version of Vegas software.*

Understanding the Video Preview window

The workspace for editing video can get quite crowded, so the Video Preview window can be configured in a number of ways to make it more useful. The Video Preview window can be used on a separate monitor (if your video hardware supports this feature), docked at the bottom of the workspace, or floated freely on the screen.

Docked window

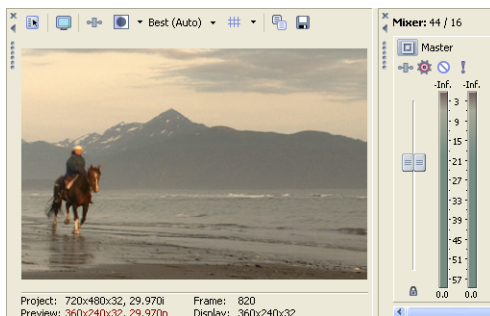

Floating window

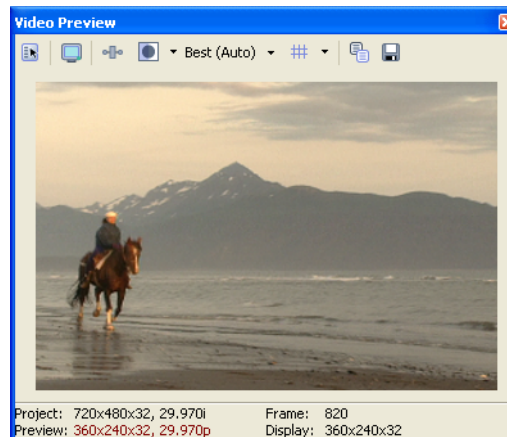

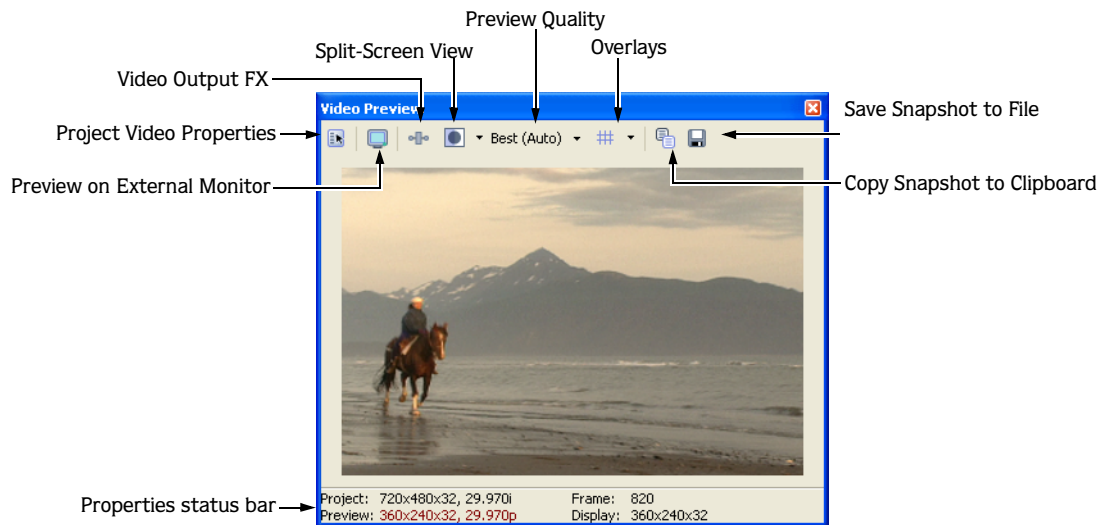

Button	Description
Project Video Properties	Displays the project's properties (pg. 201).
Preview on External Monitor	Sends the preview out to an external monitor. This only functions if your hardware supports this feature (pg. 296).
Video Output FX	Opens the Video Output FX window for adding video effects plug-ins for the entire project (pg. 205).
Split-Screen View	Turns split-screen previews on or off. Split-screen previews allow you to split the preview window so you can see your affected and unaffected video or your video and the contents of your clipboard at the same time.
Preview Quality	Changes the preview resolution and display size. You can choose a lower resolution to drop fewer frames during playback. Choose an Auto option to display the preview at the current Video Preview window size; choose a Full option to display the preview at project size. Note: If your project properties are set to either the Blend or Interpolate deinterlace method, you will not see the effects of deinterlacing in Draft and Preview quality preview modes. Deinterlacing only occurs in the Good and Best quality preview modes.
Overlays	Options include safe areas, grids, and individual channels.
Copy Snapshot to Clipboard	Copies the contents of the frame to the clipboard
Save Snapshot to File	Saves the contents of the preview window as a JPEG or PNG. The new image file is automatically saved to the Media Pool (pg. 191).

Using the Video Preview window shortcut menu

Right-click the Video Preview window to adjust the following options:

- Choose **Default Background**, **Black Background**, or **White Background** to set the background color for the window.
- **Simulate Device Aspect Ratio** displays the output in square pixels. This can prevent distortion of the preview when using sources with rectangular pixels. This does not affect the final render.
- **Show Toolbar** toggles the toolbar at the top of the window.
- **Show Status Bar** toggles the information display at the bottom of the window.

Optimizing the Video Preview window

Timing and synchronization are critical aspects of any multimedia production. Because complex multimedia projects are challenging for any computer, a number of tools are provided to maintain real-time playback even though the computer may not be able to process the data quickly enough.

Reducing preview quality

You can adjust the resolution of the Video Preview window and the quality of the preview rendering in order to improve playback. Lower-resolution previews are less clear but allow more frames to be displayed per second. This may be particularly important with projects that use overlays, transitions, and effects. Click the Preview Quality button to choose different preview resolutions.

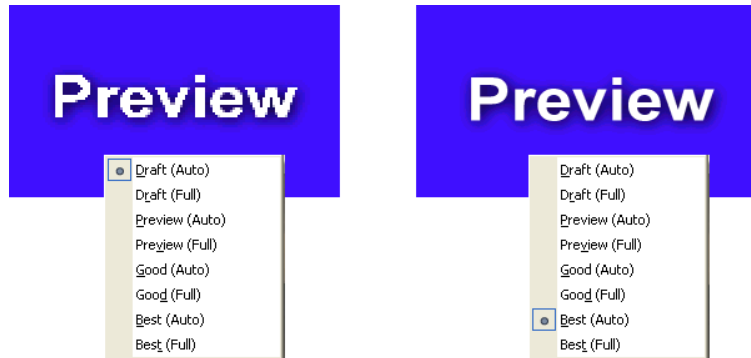

Note: To view the effects of the deinterlacing method you chose in your project properties, you will need to use the Good or Best quality preview mode. The Draft and Preview quality preview modes do not deinterlace.

Prerendering video

There are times where nothing but a full, high-quality preview will do. In these cases, Vegas software can take the time necessary to selectively render only the portions of your project that need extra processing. These sections are prerendered and short files are created to use for previews. The prerendering can take anywhere from a few seconds to a few minutes, depending on the length and complexity of the video.

Once these temporary files have been created, they are used whenever those sections of the project are played back, increasing playback quality and performance. As long as no changes are made to the events in the prerendered sections, the newly created files continue to be used for previews, even if changes are made to other sections of the project.

1. To prerender a portion of the project, create a selection containing the portion you want to prerender.
2. From the **Tools** menu, choose **Selectively Prerender Video**. The Prerender Video dialog appears.
3. Select the type of prerender file to create in the Prerender as drop-down list. Click Custom to configure any custom compression options.
4. To preview just a portion of the project, verify that Render loop region only is selected. To create a prerender of the entire project, clear this check box.
5. Click OK. A progress bar displays the progress of the render.

When prerendering is complete, green bars appear at the top of the timeline indicating the sections that have been prerendered.

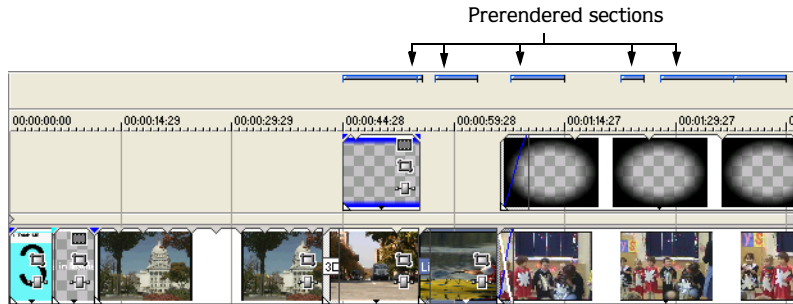

As a default, these preview files are saved when a project is closed. To delete these files when you close the project, from the **Options** menu, choose **Preferences** and, on the General tab, clear the Save active previews on project close check box.

You can set the location of these preview files by clicking the Properties button () and choosing a Prerendered files folder in the Project Properties dialog. Ideally, this folder should be on a different physical drive from where Windows is installed. You can delete prerendered preview files from your hard disk by choosing **Clean Up Prerendered Video** from the **Tools** menu.

Note: Each prerendered section will consist of no more than 10 seconds (approximately 40 megabytes). Because selective prerendering creates multiple files, minor editing on the timeline will not invalidate all of your prerendered video—only the sections you modify will need to be rerendered.

Building dynamic RAM previews

 *Dynamic RAM previews are only available in the full version of Vegas software.*

Video frames are automatically dropped when previewing if the computer can't keep up with processing demands. This means that you may not be seeing all video frames as you preview your project. If you prefer not to prerender your project, there is another option for improving previews of selected portions of a project. A portion of your RAM is dedicated to cache video frames that Vegas software cannot render in real time.

A cache of 16 MB is automatically maintained for dynamic RAM previews. To change the cache amount, choose **Preferences** from the **Options** menu and change the Dynamic RAM Preview Max value on the Video tab.

Note: Although not all frames appear in previews of a project, all frames are included when you render a file. For more information, see [Rendering a project](#) on page 271.

You can make a time selection and add each frame in the selection to the cache. Once the frames are cached, all video frames can display in a selection.

1. Select a region containing the frames you want to cache.
2. From the **Tools** menu, choose **Build Dynamic RAM Preview**.

Vegas software plays through the time selection and builds the cache frame by frame.



Using split-screen previewing

Click the Split-Screen View button () in the Video Preview window to turn split-screen previews on or off.

Split-screen previews allow you to split the Video Preview window so you can see your affected and unaffected video or your video and the contents of the clipboard at the same time. Use split-screen previews to fine-tune video effects or to match colors for color correction.

Note: *The Video Preview window temporarily enters split-screen preview mode when you slip-trim a video event. This temporary split-screen mode allows you to see the event's first and last frame as you trim. You can toggle this preview mode by selecting or clearing the Show video event edge frames in Video Preview window during edits check box on the General tab of the Preferences dialog.*



Previewing affected and unprocessed video

1. Click the down arrow next to the Split-Screen View button () and choose FX Bypassed from the menu.
2. Select the Split-Screen View button (). The cursor is displayed as a .
3. Choose a preset selection or drag in the Video Preview section to create a selection. This selection will display the unprocessed video. In the following example, the Add Noise plug-in was applied to the event, and the selection displays the original video.

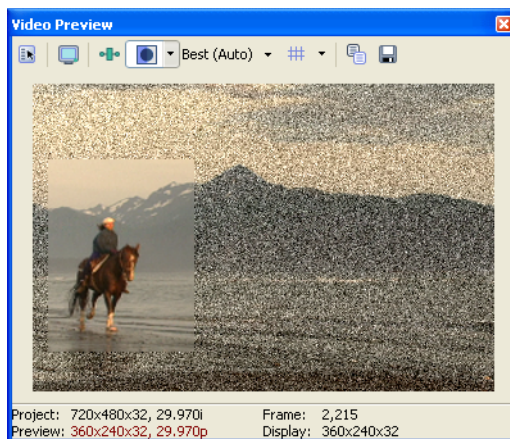
Tip: *Double-click in the Video Preview window to select the full window, or drag again to replace the existing selection.*





Showing the video at the cursor position and the contents of the clipboard

1. Position the cursor on the timeline and click the Copy Snapshot () in the Video Preview window to copy a frame to the clipboard.
2. Position the cursor at another point on the timeline.
3. Click the down arrow next to the Split-Screen View button () and choose **Clipboard** from the menu.
4. Select the Split-Screen View button ().
5. Choose a preset selection or drag in the Video Preview section to create a selection. This selection will display the contents of the clipboard.

Tip: Double-click in the Video Preview window to select the full window, or drag again to replace the existing selection.

Changing the selection for displaying split-screen views

Click the down arrow next to the Split-Screen View button () and choose **Select Right Half**, **Select Left Half**, or **Select All** to indicate which portion of the Video Preview window you want to use to display unprocessed video or the contents of the clipboard.

When the Split-Screen View button () is selected, the cursor is displayed as a . Drag a rectangle in the Video Preview window to create a custom selection.

Identifying safe areas

The Video Preview window displays the entire video frame data. However, most television monitors do not display all of this data. Previewing the video on a television monitor is the only way to verify what frame information will display. You should also note that individual television monitors vary in what they display. While there is no substitute for previewing on a television, safe areas are a good method of estimating the extent of the masking.

1. Click the down arrow next to the Overlays button () and choose **Safe Areas**.
2. Click the Overlays button to toggle the safe areas display on or off. The display shows two areas:
 - The safe action area is the frame area that is visible on a television screen.
 - The safe title area is a suggested area to limit the extent of titles. It is always smaller than the safe action area.

Tip: To customize safe area sizes, choose **Preferences** on the **Options** menu, and on the **Video** tab, enter the Action safe area and Title safe area values as a percent of the frame size. For more information, see [Video tab](#) on page 291.

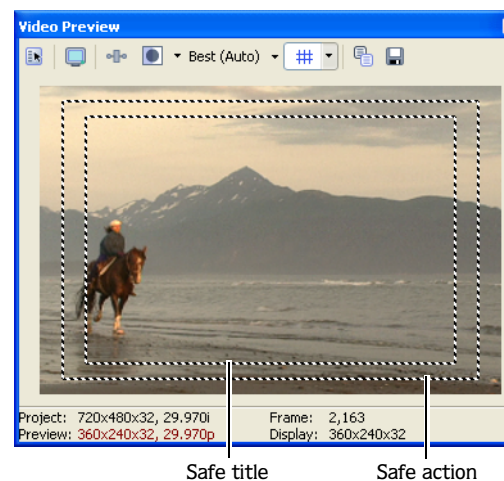

Viewing the grid

The Video Preview window can display vertical and horizontal lines over your video. You can use the grid to help you align objects. To view the grid, click the down arrow next to the Overlays button () and choose Grid.

Set the grid spacing using the Horizontal grid divisions and Vertical grid divisions settings on the Video tab in the Preferences dialog.

Isolating color channels

The Video Preview window allows you to select a specific channel to be isolated and whether the channel should be displayed in grayscale only. To display a channel, click the down arrow next to the Overlays button () and choose a color channel.

Note: Use the Alpha as Grayscale setting to isolate the Alpha channel mask and display it in grayscale.

Monitoring video with scopes

 Video scopes are only available in the full version of Vegas software.

From the **View** menu, choose **Video Scopes** to toggle the display of the Video Scopes window.

Broadcast video uses a narrower range of color than the RGB you see on your computer. When you broadcast a project that contains out-of-range colors, you can introduce image problems or even noise into the audio stream.

Use the scopes to analyze the your video and adjust accordingly with the Brightness and Contrast, Broadcast Colors, Color Corrector, Color Corrector (Secondary), and Levels plug-ins before rendering.

Choose a setting from the drop-down list to choose which scope you want to display.

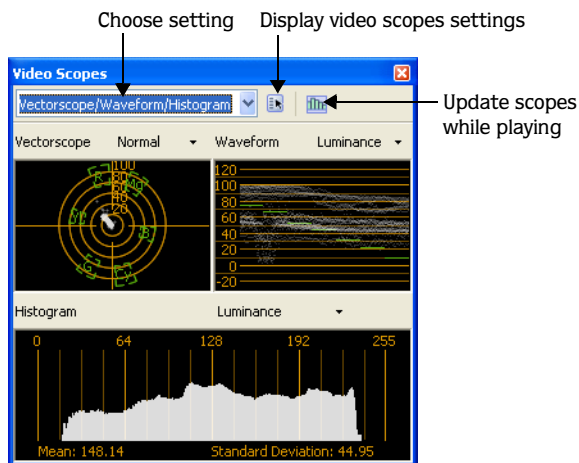

Note: If your video hardware will add a 7.5 IRE setup, click the Settings button (⚙️) and select the 7.5 IRE Setup check box in the Video Scopes Settings dialog. Black will be displayed as 7.5 in the waveform monitor. If your video hardware does not add a 7.5 setup, clear the check box, and black will be displayed as 0.

Displaying chrominance using the vectorscope monitor

The vectorscope monitor in the Video Scopes window allows you to monitor the chrominance (color content) of your video signal. The monitor plots hue and saturation on a color wheel.

The vectorscope displays targets for broadcast-legal saturations of red (R), magenta (Mg), blue (B), cyan (Cy), green (G), and yellow (Yl). Individual colors in your video signal are displayed as dots in the vectorscope. A dot's distance from the center of the scope represents its saturation, and the angle of the line from the dot to the center of the scope represents its hue.

For example, if an image has a blue cast, the distribution of dots in the vectorscope will be concentrated toward the blue portion of the color wheel. If the image includes out-of-range blue values, vectorscope display will extend beyond the blue target.

You can use the vectorscope to calibrate color between scenes. Without calibration, you may see noticeable color differences between scenes from multicamera shoots.

1. From the **View** menu, choose **Video Scopes** to toggle the display of the Video Scopes window.
2. Choose **Vectorscope** from the drop-down list.
3. Position the cursor in the frame you want to analyze. If the Update Scopes While Playing button (⏮️) is selected, you can monitor your video during playback.
4. The vectorscope monitor displays the chrominance of the video signal:

Frame



Vectorscope display of frame

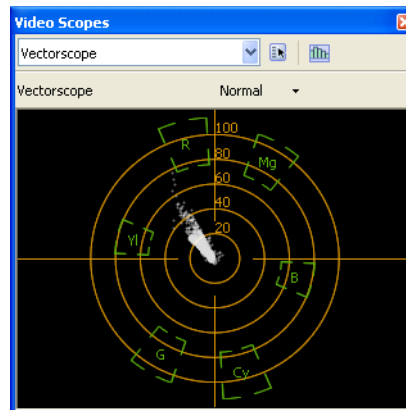

5. Hover over a portion of the monitor to display the chroma value at the pointer position:

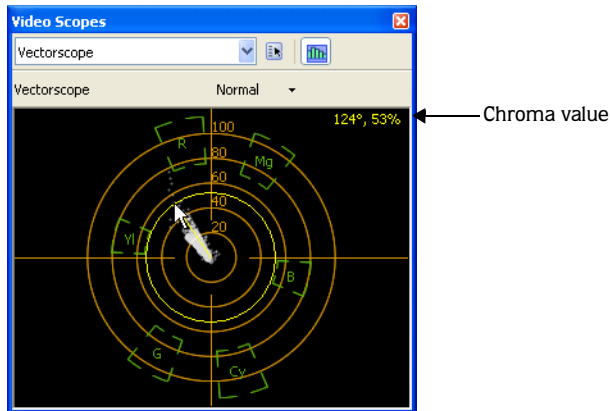

Displaying luminance using the waveform monitor

The waveform monitor in the Video Scopes window allows you to monitor the luminance (brightness or Y component) of your video signal. The monitor plots luminance on the vertical axis and the width of the current frame on the horizontal axis.

If you want to include chroma (color or C component) information in the waveform monitor, choose **Composite** from the drop-down list at the top of the monitor window. When you choose **Luminance**, chroma information is omitted.

1. From the **View** menu, choose **Video Scopes** to toggle the display of the Video Scopes window.
2. Choose **Waveform** from the drop-down list.
3. Position the cursor in the frame you want to analyze. If the **Update Scopes While Playing** button () is selected, you can monitor the waveform during playback.
4. The waveform monitor displays the luminance of the video signal:

Frame



Waveform display of frame

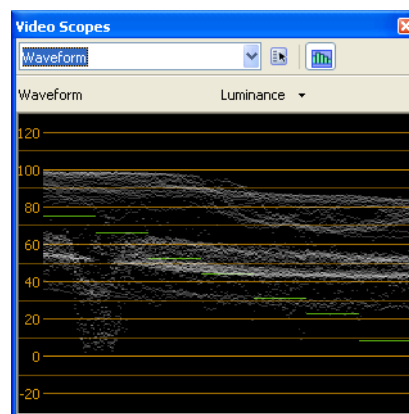

5. Hover over a portion of the monitor to display the luma value at the pointer position:

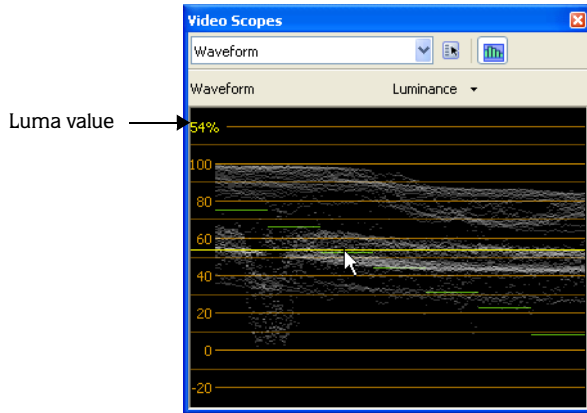

Displaying color levels and contrast using the histogram monitor

The histogram monitor in the Video Scopes window allows you to monitor color levels and contrast of your video. Use the histogram before rendering your project to find and correct out-of-range values that could cause problems on the destination playback device.

The bar graph plots the number of pixels that exist for each color intensity. For example, when using the **Blue** setting, the vertical axis represents the number of pixels, and the horizontal axis represents the RGB color range from 0,0,0 to 0,0,255.

To get acquainted with the histogram, use an external monitor to preview your video and watch the video output and histogram as you use plug-ins to modify the colors.

1. From the **View** menu, choose **Video Scopes** to toggle the display of the Video Scopes window.
2. Choose **Histogram** from the drop-down list.
3. Choose a histogram type from the menu:
 - **Luminance:** charts the luminance or brightness of colors in your video.
 - **Red:** charts the red tones in your video.
 - **Green:** charts the green tones in your video.
 - **Blue:** charts the blue tones in your video.
 - **Alpha:** charts the alpha channel (transparency) in your video.
 - **Luminance/R/G/B:** stacks luminance and RGB charts.
4. Position the cursor in the frame you want to analyze. If the Update Scopes While Playing button () is selected, you can monitor your video during playback.
5. Use the histogram to evaluate the colors in your video. The Mean value indicates the average intensity of all pixels in the graph, and the Standard Deviation value indicates the average percentage by which pixels in the graph vary from the Mean value.

6. Use plug-ins such as Brightness and Contrast, Broadcast Colors, and Levels to adjust the color. For more information, see *Using video effects* on page 205.

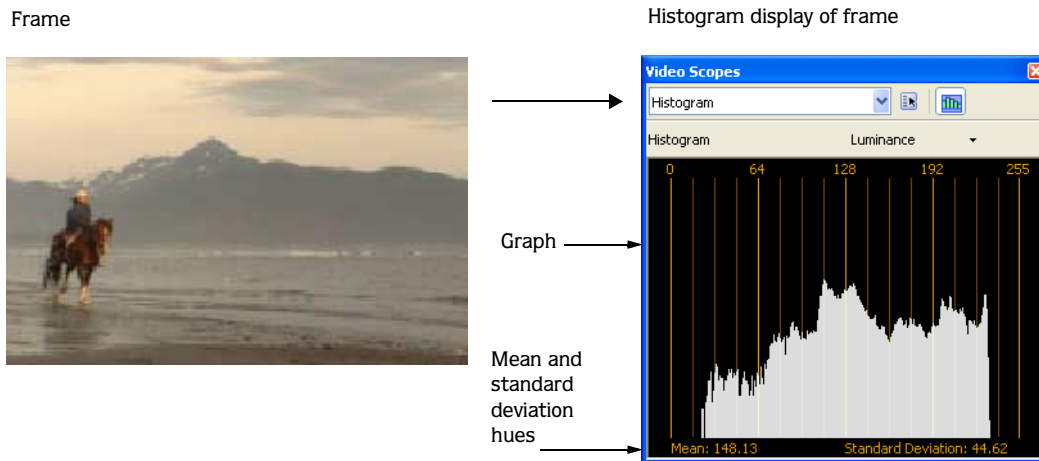

Displaying RGB components with RGB parade monitor

The RGB parade monitor in the Video Scopes window displays waveforms for the red, green, and blue components of your video signal. The monitor plots RGB values from 0-255 on the vertical axis and three times on the horizontal axis.

The parade monitor helps you determine whether the individual RGB components of your video signal are within limits and whether the total video signal is clipping.

1. From the **View** menu, choose **Video Scopes** to toggle the display of the Video Scopes window.
2. Choose **RGB Parade** from the drop-down list.
3. Position the cursor in the frame you want to analyze. If the Update Scopes While Playing button () is selected, you can monitor your video during playback.
4. The waveform monitor displays the RGB values of the video signal. Hover over the monitor to display the RGB value at the pointer position:

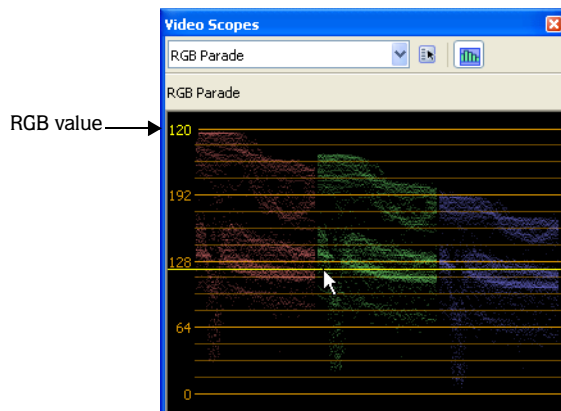

Adjusting video scope settings

Click the Settings button (⚙️) in the Video Scopes window to set your display options. These options adjust the display of data in the Video Scopes window and have no effect on your data.

7.5 IRE setup

If your video hardware will add a 7.5 IRE setup, you can configure the Video Scopes window so the display will be consistent with an external scope connected to a device that adds 7.5 IRE setup.

NTSC video in the United States adds 7.5 IRE setup to convert black to 7.5 IRE. Consumer video hardware typically does not add 7.5 IRE setup, and most professional hardware allows you to turn 7.5 IRE setup on or off. PAL video and NTSC video in Japan do not add setup.

Refer to your video hardware documentation to determine whether your hardware adds 7.5 IRE setup.

1. Click the Settings button (⚙️) in the Video Scopes window.
2. Select the 7.5 IRE Setup check box in the Video Scopes Settings dialog.

Black will be displayed as 7.5 in the waveform monitor. If your video hardware does not add 7.5 setup, clear the check box.

Studio RGB display

RGB values on your computer can range from 0 to 255. Studio RGB values range from 16 to 235. If you want to limit the display of the Video Scopes window to studio RGB standards, perform the following steps:

1. Click the Settings button (⚙️) in the Video Scopes window.
2. Select the Studio RGB (16 to 235) check box in the Video Scopes Settings dialog.

Whether you need to use the Studio RGB (16 to 235) setting depends on the DV codec you will use to render your video before printing to tape. Suggested settings follow. Refer to the codec's documentation to determine whether the Studio RGB (16 to 235) check box should be selected.

Codec	Studio RGB Setting
Sony Pictures Digital DV	On
Microsoft® DV	Off
Matrox® DV	Off
MainConcept™ DV	Off
Canopus®	On
Apple® QuickTime™ DV	Off

If the Use Microsoft DV codec check box is selected on the General tab of the Preferences dialog, the Microsoft DV codec will be used.

If the Ignore third-party DV codecs check box is selected and the Use Microsoft DV codec check box is cleared on the General tab of the Preferences dialog, the Sony Pictures Digital DV codec will be used.

You can render using a third-party DV codec by choosing a specific codec from the Video format drop-down list on the Video tab of the Custom Template dialog.

Previewing in a player

You can create a full-quality preview that automatically plays in the appropriate media player. You can preview the entire project or select a portion.

1. To preview a portion of the project, create a selection containing the portion you want to preview.
2. From the **Tools** menu, choose **Preview in Player**.
3. Select the type of preview file to create. Select a template or click Custom to configure any compression options.
4. To preview just a portion of the project, verify that **Render loop region only** is selected. To create a preview of the entire project, clear this check box.
5. Click **OK**.

A progress bar displays the progress of the render. When finished, the file automatically plays in the appropriate media player.

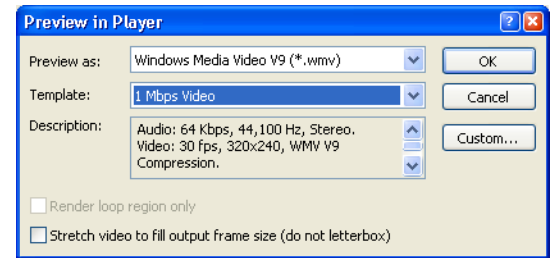

Using an external monitor

You can feed video directly from the timeline to a television monitor. With this feature, you can make your final editing decisions on a broadcast monitor (which differs significantly from a computer monitor) before printing the project to tape. To use an external monitor, you must have:

- OHCI-compliant IEEE-1394 DV card
- DV camcorder or DV-to-analog converter box

While configuring your computer for DV external monitor previewing is not difficult, the setup may require some troubleshooting. The Vegas forum is a good resource for peer-to-peer system troubleshooting:

<http://mediasoftware.sonypictures.com/forums>

Setting up an external monitor

The diagram below shows the preferred setup for sending video from the timeline to an external television monitor.

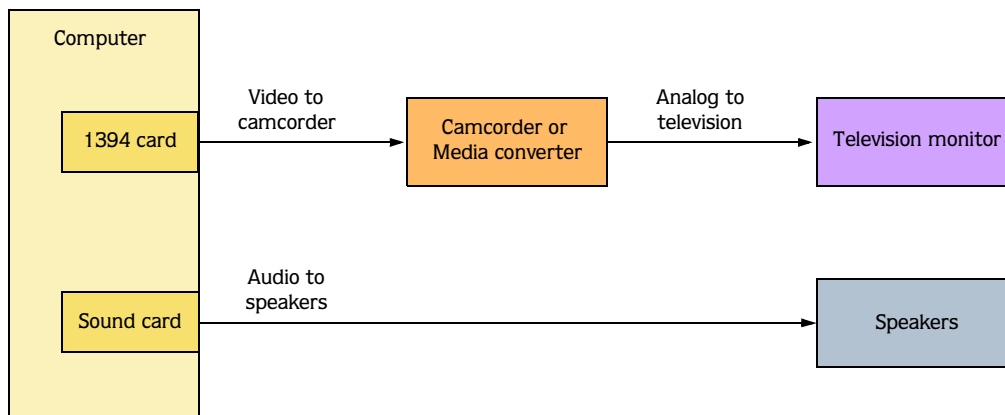

The video conforms to DV format and feeds through the 1394 card to the DV device (camcorder or DV-to-analog media converter). The DV device sends analog output to the television monitor.

Note: *The DV device must support pass-through in order to use an external monitor. Some PAL camcorders do not support this feature.*

Previewing audio

External monitor previewing differs in one respect from printing to tape from the timeline: no audio is sent through the 1394 card. As shown in the illustration above, the audio is routed to the sound card and then on to the mixer (if present) and speakers. This allows you to mix your audio on better speakers than are typically found in television monitors.

Before printing to tape, you may wish to preview the audio through the television monitor speakers to ensure a good TV mix. You can use the print-to-tape feature to send the full video and audio to the external monitor. Follow the steps for printing to tape from the timeline (pg. 285) but do not set the camcorder to record. Both the video and audio are sent through the 1394 card to the external monitor.

Optimizing preview quality

Keep in mind that complex effects and/or transitions may not play back in real time from the timeline. What effects can and cannot be played back depends on the speed of your computer. You may want to prerender more complex portions of a project. For more information, see [Prerendering video](#) on page 255.



Note: *The compression settings used to create the prerendered video must be identical to your captured files for timeline playback to work.*

Configuring an external monitor

1. Connect your camera to the IEEE-1394 card and turn it on in VTR mode.
2. Run Vegas software.
3. From the **Options** menu, choose **Preferences**.
4. Click the Video Device tab.
5. Select your device from the Device list (e.g., OHCI Compliant IEEE-1394/DV).

The output is directed to the camcorder through the IEEE-1394 card. You can preview this output on the camcorder's LCD screen or connect the camera to a television monitor to preview the output there. Once you have verified that the external monitor settings are working correctly, you can use it to preview your project.

Verifying the external monitor configuration

1. Click the Preview on External Monitor button () on the Video Preview window.
2. Open a properly formatted AVI (e.g., a DV AVI) file in the Trimmer window.
3. Click the Play button () in the Trimmer window to test the output.

This can be a complex hardware issue. You can find more detailed information at the Sony Pictures Digital Media Software and Services Web site (<http://www.sony.com/mediasoftware>).

For more information, see [Video device tab](#) on page 296.



Saving, Rendering, and Printing Projects

Vegas® software allows you to save and render projects into many different multimedia formats. When you render your Vegas project, the project itself is not altered, but rather can be rendered in any number of different formats.

This chapter explains saving a project and using the Save As and Render As functions. In addition, you will find reference information for the rendering options available. This chapter also describes the different options for delivering your projects, such as printing to DV tape, burning a Video CD, or burning a multimedia CD.

 Using custom settings to render to streaming media formats is available only in the full version of Vegas software. Printing to tape from the timeline and CD burning are only available in the full version of Vegas software.

Saving a project

A Vegas project is saved as a small VEG file. This file contains all of the information needed to recreate your project: source file locations, trimming, track and bus plug-ins, volume and panning envelopes, bus assignments, assignable effects settings, etc. This is not the same as creating a final media file, which is done with the Render As command.

Note: The option is also provided of saving a project as an Edit Decision List (EDL). For more information, see [Creating an EDL on page 198](#).

1. Click the Save button (). The first time a project is saved, the Save As dialog appears.
In subsequent saves, the Save As dialog is bypassed, your existing file name is retained, and your project is updated to include any changes.
2. Select Vegas Project File (.veg) from the Save as type list (default).
3. Select the drive and folder where you want to store the project.
4. Type the project name in the File name box.
5. Click Save.

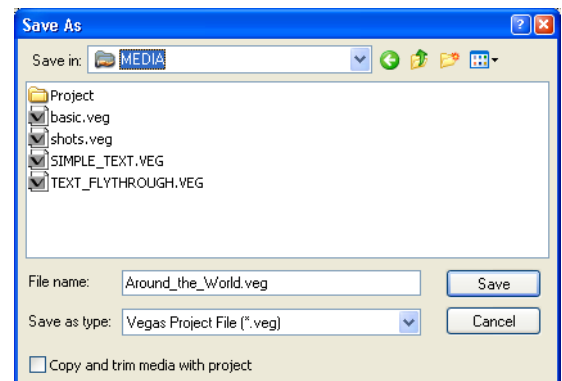

Creating a copy of a project (using Save As...)

After you have been working with your project, you can use the **Save As** command in the **File** menu to create a copy of the small project file with a different name. Since multimedia projects can be very complex, and since Vegas project files are so small, saving a number of different versions of a project is a low-risk way to try new techniques.

1. From the **File** menu, choose **Save As**. The Save As dialog appears.
2. Select the drive and folder where you want to store the project.
3. Type a new name in the File name box.
4. Click the Save button on the Save As dialog.

Saving a project with media

The option of saving both the project file (VEG) and the media files to a common location is also provided. You can choose to save all media files along with the project file or allow Vegas software to consolidate and trim the media for you. With this second option, media storage is optimized by saving only those portions of files that are used in the project and by eliminating unused takes.

 The option to consolidate and trim media when saving is only available in the full version of Vegas software.

Note: Peak files (.sfk) and audio proxy files (.sfap0) are not saved with the project when Copy and trim media with project is selected. Because these files can regenerate as needed, they do not need to be archived. For more information, see [Peak File \(.sfk\)](#) on page 333 or [Audio proxy files \(.sfap0\)](#) on page 322.

1. From the **File** menu, choose **Save As**. The Save As dialog appears.
2. Select the drive and folder where you want to store the project.
3. Type the project name in the File name box.
4. Select the Copy and trim media with project check box.
5. Click Save. The Copy Media Options dialog appears.
6. Select the appropriate option:

- Select the Copy all media radio button to copy all media files to the same location as the Vegas project file.
- Select the Create trimmed copies of source media radio button to optimize media storage by saving only those portions of media files used in events and discarding unused takes. Audio files are saved as Wave format if under 2 GB (as Wave64 if over 2 GB) and DV video is saved as AVI. Non-DV video files are copied in full.

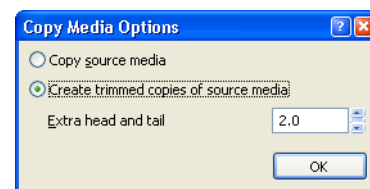

Enter an Extra head and tail (seconds) value to indicate how much time should be included before and after the trimmed media. For example, if the project contains a 2-minute media file, but the event on the timeline for that file lasts only from 1:00 to 1:20, you could enter 5 seconds in the Extra Head and Tail box to have the media file saved from 0:55 to 1:25 (5 seconds added to the head and tail of the event).

Including this extra material allows space for future edits.

7. Click OK. The project file is saved and the related media files to the location you specified.

Autosaving a project

A backup copy of your project is automatically saved every five minutes. If your system crashes, you are prompted to open the backup file the next time you start the program.

Backup files are saved in the location specified in the Temporary files folder box on the General tab of the Preferences dialog. Files are saved with the .autosave.veg extension and are deleted when you close Vegas software.

If you prefer not to autosave your project, you can clear the Enable autosave check box on the General tab of the Preferences dialog.

Vegas software also creates .veg-bak files in your project folder when you save a project to allow you to return to the project's last-saved state. Creation of .veg-bak files is independent of autosaving.

Rendering a project

Rendering refers to the process of converting a project into a single new multimedia file and formatting it for the desired playback method: media player, Internet streaming media, CD-ROM, video tape, etc. The project file is not overwritten, deleted, or altered during the rendering process. You can return to the original project to make edits or adjustments and render it again later.

Rendering a video file can take quite a bit of time, depending on the complexity of your project, the speed of your CPU, and the final format you have selected. For longer projects, you might want to plan to render your movie overnight or when you are not using your computer.

The process for rendering a project is essentially the same, regardless of the final format of the rendered file.

Note: For specific information on 5.1 surround projects, see [Rendering surround projects](#) on page 185.

1. From the **File** menu, choose **Render As**. The Render As dialog appears.
2. Select the drive and folder where you want to save the rendered file.
3. Type a new name in the File name box, if necessary.
4. In the Save as type drop-down list, choose the appropriate format. For more information, see [Selecting a file format](#) on page 272.
5. In the Template drop-down list, select the appropriate template.

Tip: If your source media is in DV format, select a DV template. For more information, see [Working in DV format](#) on page 198.

You can customize the rendering settings by clicking Custom. For more information, see [Customizing the rendering process](#) on page 275.

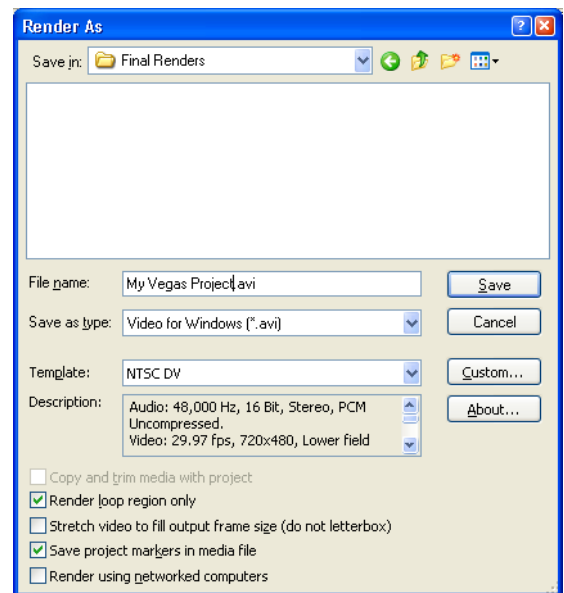

6. Select any check boxes as needed:

- Select the Render loop region only check box to render only the portion of your project within the loop selection.
- Select the Stretch video to fill output frame size (do not letterbox) check box to adjust the aspect ratio so the output frame is filled on all edges. Clear the check box to maintain the current aspect ratio and add black borders to fill the extra frame area (letterbox). This option is useful when the desired output format does not match the frame aspect ratio of your project.
- Select the Save project markers in media file check box to save any regions and markers in your project to the final rendered file.
- Select the Render using networked computers check box if you want to queue multiple renders on a single computer or to harness the power of those other computers to speed up your rendering times. *For more information, see [Rendering with networked computers](#) on page 279.*

7. Click Save. A small dialog box appears, displaying the progress of the render. You can cancel the rendering process by clicking the Cancel button in the dialog box. You can also view the progress of the render or cancel the render using the status bar in the lower-left corner of the window.

Selecting a file format

The following table describes the formats available for rendering your project:

Format Name	Extension	Definition
Audio Interchange File Format	.aif	An audio file format developed by Apple®.
MPEG-1 and MPEG-2	.mpg	Some versions of Vegas software also support MPEG-1 and MPEG-2 file creation through the use of MainConcept® MPEG technology (see notes following table).
MPEG Layer 3	.mp3	Compressed audio format. You may render up to 20 .mp3 files without registering the optional plug-in.
OggVorbis	.ogg	A patent-free audio encoding and streaming technology.
QuickTime™	.mov	Apple® QuickTime multimedia format.
RealMedia®	.rm	The RealNetworks® standard for streaming media via the Web. This option renders both audio and video into one file.
Perfect Clarity Audio®	.pca	A proprietary format from Sony Pictures Digital that is compressed and completely lossless (see notes following table).
Wave64™	.w64	A Sony Pictures Digital proprietary format that allows wave files that are (practically) unrestricted by file size (see notes following table).
Video for Windows®	.avi	The standard video file format used on Microsoft® Windows®-based computers. This option renders both audio and video into one file.
Wave (Microsoft)	.wav	The standard audio file format used on Microsoft Windows-based computers.
Wave (Scott Studios)	.wav	Standard audio format used with Scott Studios systems.
Windows Media® Audio	.wma	The Microsoft audio-only format used to create files for streaming or downloading via the Web.
Windows Media Format	.wmv	The Microsoft standard used for streaming audio and video media via the Web.

More about the MPEG format

MPEG renders can sometimes take more time than renders with some other formats. MPEG video files can be played back on most computer systems. MPEG video files can also be burned to CDs or DVDs for playback in standalone VCD, SCVD, and DVD players. Sony Pictures Digital cannot guarantee the compatibility of MPEG files with VCD/DVD authoring software or VCD, SCVD, and DVD standalone players. Consult your specific authoring software's documentation for information on what constitutes a valid file and then customize the MPEG rendering properties to match.

Note: For information on preparing files for DVD Architect™ projects, please see the DVD Architect documentation.

More about the Wave64 and Perfect Clarity Audio formats

The Wave64 (.w64) and Perfect Clarity Audio (.pca) formats are proprietary formats developed by Sony Pictures Digital to work around some limitations inherent in other formats. Currently, neither is compatible with many other applications and may not be playable in other media players, but both are excellent choices for Sony Pictures Digital projects.

- **Wave64** files work around the maximum file size limitation inherent in the WAV format. The Wave64 format has no maximum file size and is useful in long format productions.
- **Perfect Clarity Audio** is a compressed format that is completely lossless. Unlike MP3 and other highly compressed formats which are lossy, 100% of the quality of your audio is maintained by using the PCA format.

More about video formats

When you create a final movie, you will find that there are dozens of formats to choose from, each having many customization options. The destination of your final movie is the most important factor in selecting a format. Movies created for broadcast television must be of the highest quality, but for many other destinations, such as a CD-ROM or the Internet, you may have to sacrifice some quality when you render the file. Heavy compression may create visible artifacts in the video, such as when you create streaming video for the Internet. Every case is different and it is necessary to experiment to obtain the best results.

VCR or television

If you are creating a movie that you want to send back out to a television, a VCR or a camcorder, there is only one choice: use the same settings as the original video.

There is no way to improve upon the quality of your original video (as far as compression is concerned). If you have captured your video at 640X480, at 24 fps in an MJPEG codec, then that is how you should set up your final movie. This is the only way to maintain 100% quality. For more information, see [Working in DV format on page 198](#).

Computer

This can be the most complicated case because you have to decide exactly which computer it is going to be played back on, how fast it is, what software is installed, and how you are going to get it there (e.g., burn to a CD). Your biggest concern with creating a video file is compatibility. When you create a movie, you must select a specific codec to compress the video. That same codec must then be used to view the movie. This is not a problem if you are viewing the movie on your own computer, since the appropriate codec is already installed. To ensure that your audience has the appropriate software, you should use a fairly universal codec. Intel Indeo, Cinepak, and QuickTime (which is not a codec, but installs with a number of different codecs) are all widely available.

Internet

When video on the Internet is discussed, people almost always mean streaming. There are two streaming media formats that come with Vegas software: RealMedia and Windows Media Format. There is nothing particularly magical about streaming video, and the three rules of creating video files for the Internet are as follows: compress, compress, and compress. The smaller the file size the better, and this inevitably results in a loss of quality. There are two main places where you can save space: frame dimensions and frame rate. Typical Internet video files should be about 160X120 and should rarely exceed 320X240. This is not very big, and video with lots of detail does not translate well to this frame size. The frame rate should also be as low as possible, with 15 fps being a good maximum. Fast action, pans, and moving backgrounds (e.g., tree leaves or ocean waves) do not compress well. Streaming media files must be placed on a special Internet server in order to stream properly.

Customizing the rendering process

Every media file format has different variables and controls. You can use a template to automatically configure a particular format for a particular destination.

You can also choose to create custom settings for your render by clicking Custom. Once you have customized the settings, you can create your own template so that you can reuse the custom settings at a later time.

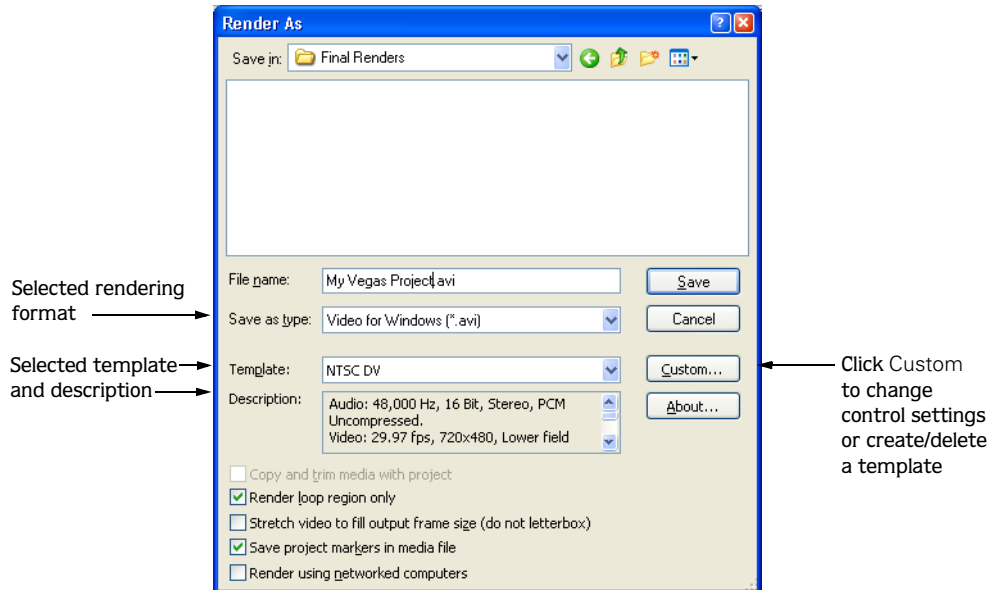

Customizing the Render As settings

1. From the **File** menu, choose **Render As**.
2. In the Render As dialog, choose the format [e.g., Video for Windows (.avi)].
3. Click Custom. The Custom Template dialog appears.

Note: Built-in templates cannot be edited.

4. Adjust the settings in each of the tabs as desired.

Note: When determining bit rates, 1K=1024.

5. Click OK to close the Custom Template dialog.
6. Enter a name and location for the new file and click Save.

Saving custom settings as a template

You can save customized rendering settings for future use. One of the most important reasons to save a new template is to save the specific compression codec used to create the final media file, since this is not predetermined by the project properties.

1. Modify the parameters in the Custom Template dialog.

Note: When determining bit rates, 1K=1024.

2. In the Template drop-down list, enter a name for the new template.

Note: Built-in templates cannot be edited.

3. Click the Save Template button ().

To use the new template in the future, choose it from the Template list in the Save As dialog.

Tip: To delete a template, select it from the drop-down list and click the Delete button (.

Creating custom rendering settings for AVI files

The options that appear in the Custom Template dialog depend on which format you choose for your rendered file. This section provides descriptions of the Custom Template options for creating a Video for Windows (AVI) file. For descriptions of the options used to customize other formats, use the What's This button () in the specific Custom Template dialog for that format. For more information, see [What's This? help on page 17](#).

Some of the rendering settings are identical to your Project Properties and can be saved as a part of a project template. Final render settings override Project Properties settings. For more information, see [Modifying project video properties on page 201](#).

The Custom Template dialog for rendering to an AVI file has three tabs: Project, Video, and Audio.

Project tab

Video rendering quality

Higher quality settings result in longer rendering times. Good is the default.

Video tab

Include video

Select this check box to include the video stream and enable the remaining fields on the dialog. If you do not want to include the video stream, clear this check box.

Frame size

Frame size contributes to quality and file size. The appropriate frame size is determined by the final destination of the movie. See your video capture card's documentation for more information. The final frame size of the movie can be different from the project's default settings.

Frame rate

Frame rate is important in determining the quality and size of the final media file. The appropriate frame rate is determined by the final destination of the movie. See your video capture card's manual for more information. The final rendered multimedia file can have a different frame rate from the project itself.

Field order

Video that is displayed on a television monitor is interlaced. This means that every frame of video is actually composed of two fields, each of which is made up of half of the lines that make the final frame. These two fields are woven together in alternate lines, but which of the two fields is displayed first can be important. Choose **None (progressive scan)** to ignore interlacing for video to be displayed on a computer. For video on a television, most hardware supports **Lower Field First**. If the output is jittery or shaky on a television, or your hardware's manual specifies it, choose **Upper Field First**.

Pixel aspect ratio

A pixel is a single picture element or dot on a television or computer screen. Computers display pixels as squares: 1.0. Televisions display individual pixels as rectangles: 0.909, 0.899, or anything other than square. Using the wrong pixel aspect ratio can result in distortions or stretching of the video. Select the aspect ratio for the final movie's destination. Consult your hardware manual if you are in doubt about the appropriate ratio. The pixel aspect ratio and frame size determine the frame's aspect ratio.

Video format

Codec, which stands for COmpressor/DECompressor, is the mathematical algorithm used to compress a media file. The codec directly determines the size and quality of the movie, as well as its compatibility with various playback devices. The final destination for the movie dictates the choice of codec. Many of the codecs used for specific rendering formats are updated periodically by their creators. For information about specific codecs, contact the codec's manufacturer.

Each codec is a small program that may have additional custom controls used to fine tune the output. Click **Configure** to adjust these parameters manually.

Quality slider

If the codec you choose in the **Video format** drop-down list supports it, use this slider to adjust the quality of the compression applied by the codec.

Interleave every

This control allows you to specify how often the audio and video streams are interleaved. Interleaving relates directly to how the data is saved in the file. For example, during the rendering process, the audio data is written in between the video data based on the frame setting that you specified. Interleaving allows for optimal playback of the AVI file.

Keyframe every

If the codec you choose in the **Video format** drop-down list supports compression keyframes, select this option to set compression keyframes to adjust the quality of the compression. More keyframes typically produce higher quality video, but a larger file size (and thus a higher data rate).

Data rate

If the codec you choose in the **Video format** drop-down list supports a data rate ceiling, select this option and enter a maximum data rate for the final file.

Render alpha channel

If the codec you choose in the **Video format** drop-down list supports alpha channel transparency, select this option to save this information with the file.

Create an OpenDML (AVI version 2.0) compatible file

Select this check box if you want to save your file as an OpenDML file. OpenDML files allow you to create files that are limited in size only by the format of your hard disk: 2GB using FAT32 or 4GB using NTFS.

Audio tab**Include audio**

Select this check box to include the audio stream and enable the remaining fields on the dialog. If you do not want to include the audio stream, clear this check box.

Audio format

This lists the audio rendering codecs that are available.

Attributes

If the codec you choose in the Audio format drop-down list supports it, select the appropriate attributes for the codec from this list.

Sample rate

The sample rate directly affects the audio's quality. The sample rate is defined as the number of times a second that data is sampled in an audio file. It is similar to the concept of resolution in an image file. The higher the setting you choose, the better the quality, but the larger the file size.

Bit depth

The bit depth directly affects the audio's quality. The bit depth is defined as how much data is used to save each sample. The higher the setting you choose, the better the quality, but the larger the file size.

Channels

You can render a project in either stereo or mono.

Rendering with networked computers

Network rendering allows you to designate a specific computer to render the entire output file, or you can distribute a single rendering job among several computers.

- Distributed network rendering splits the video into segments that are rendered by multiple computers. In this mode, each computer renders a portion of the project, and the rendered sections are then reassembled into a single file by the one computer (called the *stitch host*).

Distributed rendering is a good way to reduce the time it takes to render a project containing a significant amount of processed video (video effects, transitions, panning/cropping, track motion, and compositing). However, distributed rendering requires increased disk space and network traffic because each segment must be saved before the final output can file be generated.

Nontemporal video output formats, such as DV or uncompressed AVI, are also well suited for distributed network rendering because segments can be reassembled without re-encoding.

- Nondistributed network rendering behaves very much like standard rendering, but you can choose which computer you want to render the project. In this mode, each computer renders a complete file from a Vegas project or the loop region.

If you want to encode the same project to multiple streaming formats and bit rates, it is best to queue up multiple nondistributed jobs because streaming formats use temporal compression and you can assign different renderers to different output formats. If you have a project or output format with audio only, choose nondistributed rendering because only video is rendered in the first phase of a distributed job.

Both distributed and nondistributed rendering jobs can be queued to be performed as computing resources become available so you can render multiple projects or render the same project in multiple formats.

Rendering using a computer other than your main editing computer allows you to continue working without waiting for the render job to complete.

Setting up your computers for network rendering

The computer that initiates and manages a network render is considered the owner of the job. Each networked computer that you use for rendering is called a *renderer*. The computer that reassembles rendered segments in a distributed rendering job is called the *stitch host*. The computer that is designated to perform a nondistributed network render job is called the *render host*.

To use network rendering effectively, we recommend the following:

- 256 MB RAM in each renderer.
- 100 Mbps switched local area network.
- Your media files and output file must be in shared folders, preferably on a dedicated file server. All renderers must have permission to read, write, create, and delete files in the shared folders.

Before network rendering begins, a copy of your project will be saved in the shared output folder for use by the renderers. This version will have all media paths remapped based on the Network Render Service file mappings. *For more information, see [Setting file mappings](#) on page 283.*

Setting up a rendering computer

1. Install Vegas software as a render-only client.

You can install Vegas software as a render-only client on two computers for each Vegas license you purchase. However, certain file formats, such as MPEG-2, AC-3, and MP3, cannot be used on render-only clients.

2. Start the Vegas Network Render Service application (VegSrv50.exe). The service must be running and you must be logged into the computer before you can use it for rendering.
3. If necessary, you can change the TCP port the render service uses to communicate with other renderers:
 - a. Exit the Vegas Network Render Service application if it is running.
 - b. Open the NetRenderService.config file in a text editor. This file is located in the Vegas 5.0 installation folder.
 - c. Edit the `<channel ref="tcp" port="53704" />` tag in the file to reflect the port you want to use.
 - d. Save the file.
 - e. Restart the Vegas Network Render Service application.

Adding renderers to a host

1. Start the Vegas Network Render Service application (VegSrv50.exe) on the computer you will use to initiate network rendering.

If you do not start the service before starting a rendering job, it will start automatically, but it will not be visible. Right-click the  icon in the system tray and choose **Show** from the menu to display the window.

2. Select the Renderers tab. This tab allows you to edit the list of computers running the render service.

Note: A computer will be displayed on the Renderers tab only if you have logged on to Windows and the Vegas Network Render Service is running. If the computer is not in an area you can monitor easily, you can use **Ctrl+Alt+Delete** to lock the computer after logging on and starting the service.

3. Click the Host box of a blank row in the table, and then type the IP address or name of the computer you want to use as a renderer.

To find your computer name, right-click My Computer and choose **Properties** from the shortcut menu to display the System Properties dialog. Click the Computer Name tab, and your computer name is displayed in the Full computer name entry.

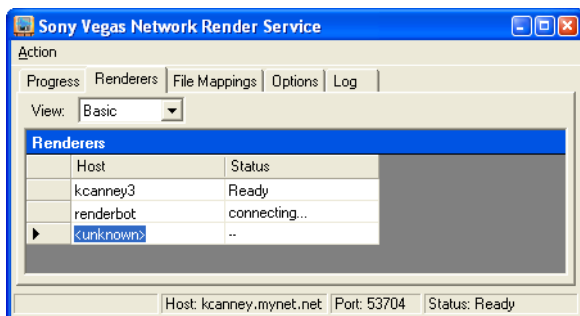

4. Press **[Enter]** to connect to the renderer. If the connection is made, the Status column will display Ready.

Troubleshooting initiation problems

If you receive an error message that indicates the Network Render Service cannot start when you start the application, you may need to resolve DNS suffixes on your computer.

1. Open a DOS window:
 - a. From the **Start** menu, choose **Run** to display the Run dialog.
 - b. In the Open box, type CMD.
 - c. Click OK. A DOS window is displayed.
2. Type ipconfig at the command prompt.

Your Windows IP Configuration information is displayed. Note the Connection-specific DNS suffix setting.
3. Update your computer's DNS suffix:
 - a. Right-click My Computer on your desktop and choose **Properties** from the shortcut menu (or press the Windows key + **Pause**) to open the System Properties dialog.
 - b. Select the Computer Name tab.
 - c. Click the Change button to display the Computer Name Changes dialog.
 - d. Click the More button to display the DNS Suffix and NetBIOS Computer Name dialog.
 - e. In the Primary DNS suffix of this computer box, type the DNS suffix you recorded in step 2.
4. Click OK to close all dialogs and restart your computer.

Using nondistributed network rendering

1. Save your project.

Your original project does not need to be saved in a shared folder. Before network rendering begins, a copy of your project will be saved in the shared output folder (see step 4) for use by the renderers. This version will have all media paths remapped based on the Network Render Service file mappings. *For more information, see [Setting file mappings](#) on page 283.*

After rendering begins, you can continue to make edits to your original project without disrupting in-progress network render tasks.

2. If you want to render only a portion of your project, create a time selection that includes the portion you want to render.
3. From the **File** menu, choose **Render As**.
4. Use the Render As dialog to choose the file format and location where you want to save your file. The location of the output file must be in a shared folder.
5. Select the Render loop region only check box in the Render As dialog if you want to render the selected portion of your project.
6. Select the Render using networked computers check box in the Render As dialog, and then click the Save button. The Network Render dialog is displayed.
7. From the Render Host drop-down list, choose the URL of the renderer you want to use to render your project.

8. The Temporary Files Location box displays the path to the folder where the temporary .veg project will be saved. If you want to use a folder other than the output folder you choose in step 4, you can choose a folder from the drop-down list or click the Browse button to choose a folder.

This folder must be in a shared location.

9. Click OK to start rendering.
10. To add a project to the queue, open the project and repeat steps 1 through 8.

You can choose a different renderer for each project or time selection if you want to render the files concurrently on separate computers. If you choose the same renderer, the rendering jobs will be queued to run sequentially on that computer.

Using distributed network rendering

1. Save your project.

Your original project does not need to be saved in a shared folder. Before network rendering begins, a copy of your project will be saved in the shared output folder (see step 4) for use by the renderers. This version will have all media paths remapped based on the Network Render Service file mappings. *For more information, see [Setting file mappings](#) on page 283.*

After rendering begins, you can continue to make edits to your original project without disrupting in-progress network render tasks.

2. From the **File** menu, choose **Render As**.
3. Use the Render As dialog to choose the file format and location where you want to save your file. The location of the output file must be in a shared folder.
4. Select the Render using networked computers check box in the Render As dialog, and then click the Save button. The Network Render dialog is displayed.
5. Select the Distribute Rendering check box in the Network Render dialog.
6. From the Stitch Host drop-down list, choose the computer you want to use to assemble the rendered segments.
7. Choose a file format for your rendered segments.
 - Select the Use Final Render Template check box if you want to render segments using the format you chose for your final output in the Render As dialog.

Use this option when you're working with uncompressed or DV files. Using the final rendering template for rendered segments makes the final stitching process fast because the segments can be copied and assembled without being re-encoded.

- Clear the Use Final Render Template check box and choose settings from the Save as Type and Template drop-down lists if you want to render segments using a format other than your final output format.

Use this option when you're rendering to a format that uses temporal compression, such as QuickTime, RealMedia, or Windows Media. Rendering segments as uncompressed or DV AVI files allows transitions and composited tracks to be rendered in a high-quality format. When the segments are stitched, the project is re-encoded using the format you chose for your final output in the Render As dialog.

8. The Temporary Files Location box displays the path to the folder where the temporary .veg project and rendered segments will be saved. If you want to use a folder other than the output folder you chose in step 3, you can choose a folder from the drop-down list or click the Browse button to choose a folder.

This folder must be in a shared location.

Tip: Choosing a folder other than the final output folder can help improve performance during the stitching phase when you render a project with uncompressed segments.

9. Click OK to start rendering.

Monitoring rendering progress

1. Right-click the  icon in your system tray and choose **Show** from the menu to display the Sony Vegas Network Render Service window.
2. Select the Progress tab. The Progress tab displays a list of the segments that are queued to render, the assigned peer, and the status.
3. Choose **Details** or **Summary** from the drop-down list in the Progress tab to see more or less information.

Setting file mappings

File mappings help remote renderers find the media used in your project. When you import media from a local disk, the file paths saved in your project are often valid only on the local machine. This can be the case even if the media resides in a shared folder.

Use the File Mappings tab to map local folders to universal paths.

Adding a file mapping

1. Right-click the  icon in your system tray and choose **Show** from the menu to display the Sony Vegas Network Render Service window.
2. Select the File Mappings tab. The tab displays a list of local folders and their universal paths.
3. Click a blank row in the table.
4. In the Local box, type the path to the local folder (c:\media, for example).
5. In the Universal box, type the UNC path or mapped drive letter to the folder (\\renderer\media, for example).

Note: Before you start rendering, verify that the remote renderer has access to the folder and is logged in. On the renderer, choose **Run** from the **Start** menu to display the Run dialog. In the Open box, type the UNC path to the folder (\\renderer\media\ in our previous example). If you're prompted to log on, type your username and password.

Creating file mappings automatically

1. Right-click the  icon in your system tray and choose **Show** from the menu to display the Sony Vegas Network Render Service window.
2. Select the File Mappings tab. The tab displays a list of local folders and their universal paths.
3. From the **Action** menu, choose **Auto-Fill File Mappings**. Shared folders on the local machine are added to the list as universal paths.

However, no mappings will be added in the following circumstances:

- If all shared folders are already listed in the table.
- If the computer does not have any shared folders.
- If your user account does not allow you to create or modify folder sharing.

Removing file mappings

1. Right-click the  icon in your system tray and choose **Show** from the menu to display the Sony Vegas Network Render Service window.
2. Select the File Mappings tab. The tab displays a list of local folders and their universal paths.
3. Right-click a mapping and choose **Delete File Mapping** from the shortcut menu to delete it. Click a blank row in the table. Choose **Delete All File Mappings** to delete all file mappings.

Setting render service options

1. Right-click the  icon in your system tray and choose **Show** from the menu to display the Sony Vegas Network Render Service window.
2. Select the Options tab.

Item	Description
Enable rendering	Select this check box if you want the local computer to be available as a renderer.
Automatically run after login	Select this check box if you want to start the service automatically after logging in to the Windows operating system.
Exit service when window is closed	Select this check box if you want to keep the service running after closing the window. If the check box is cleared, the service is minimized to the system tray when you close the window.
Exit Vegas when idle	Select this check box if you want to close the instance of Vegas software that is launched by the network render service when no jobs are in the queue. If the check box is cleared, the application continues running until you close it or exit the service.
Remove completed jobs from progress display after	Choose a setting to indicate how long jobs should be maintained on the Progress tab of the Sony Vegas Network Render Service window.
Default segment length	Choose a setting to indicate the number of frames per segment when using distributed rendering. Adjusting this value can increase performance slightly depending on the complexity of the project and your specific rendering computers. If the setting yields more than 90 segments for a rendering job, the segment length for that job is automatically increased to limit the number of segments.

Printing with Video Capture

Once you have rendered your project, you can use the Sony Pictures Digital Video Capture application (installed with Vegas software) to print your finished video onto DV tape in your video camera or VTR.

Note: *You must have an IEEE-1394/OHCI-compliant video capture card installed to use Video Capture.*

1. If you have not already done so, connect your video camera to your video capture card using the cable provided with the card.
2. In the Media Pool window, click the Capture Video button (). The Video Capture application starts.

Note: *If your video camera is properly connected, the Video Preview window in the center of the application area should display “Device connected.”*

3. Follow the instructions for printing to tape provided in the Video Capture online help. To access online help, click the **Help** menu within the Video Capture application, and choose **Contents and Index**. The Video Capture online help file displays.

Printing to DV tape

 *Print to tape from the timeline is only available in the full version of Vegas software.*

You can print either a portion of your project or the entire video right from the project timeline. Your project is examined, any complex portions are prerendered, and then printed to DV tape all in one action. For more information, see [Prerendering video](#) on page 255.

Note: *Printing to tape from the timeline can require significant drive space for temporary prerendered files. Set the Prerendered files folder on the Video tab of the Project Properties dialog to an A/V-capable drive with sufficient space. Prerendering a DV project uses approximately 228 MB/minute, so plan accordingly.*

To print to DV tape, you must first establish a connection to the video camera or VTR to which you will print. For more information, see [Video device tab](#) on page 296.

Establishing a connection to the recording device

1. On the **Tools** menu, choose **Preferences**. The Preferences dialog appears.
2. Click the Video Device tab.
3. In the Device drop-down list, select OHCI Compliant IEEE 1394/DV.
4. Click OK. The Preferences dialog closes.

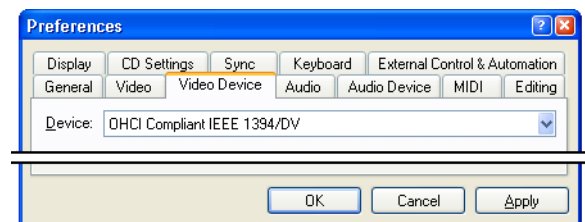

Printing to DV tape from the timeline

1. To print just a portion of your project, make a time selection in the timeline.
2. From the **Tools** menu, choose **Print Video to DV Tape**. The Conform Timeline to DV Format dialog appears. Complete the following information:
 - In the DV Template drop-down list, choose the appropriate template for rendering your video or click Custom to select custom settings. For more information, see [Customizing the rendering process on page 275](#).

Note: If you are working with a 24p progressive-scan project or you have the Allow pulldown removal when opening 24p DV check box selected on the General tab of the Preferences dialog, you will need to insert pulldown by choosing the appropriate 24p DV template from the list. To use the video footage later, choose the NTSC DV 24p (inserting 2-3-3-2 pulldown) template.

If you are not working with a 24p progressive-scan project and you cleared the Allow pulldown removal when opening 24p DV check box on the General tab of the Preferences dialog, you can use any DV template.

- To print just a portion of your project, select the Render loop region only check box.
3. Click Next. The Leader and Trailer dialog appears. Complete the following information:
 - In the Leader section, choose a test pattern, and indicate the test pattern and black duration that will precede the video. To print without a test pattern or black leader, enter 0 for the Duration value. Select the Play 1 kHz tone with test pattern check box to include a tone in the leader.
 - In the Trailer section, indicate the duration of the black to follow the video. To print without a trailer, enter 0 for the Duration value.
 4. Click Next. The Device Setup dialog appears. Choose the device control mode:
 - Choose the Manual radio button to cue the device manually and set it to record.
 - Choose the Use device control radio button to cue the device automatically based on a timecode value. Enter the timecode for recording to begin in the Device timecode box. The device must support OHCI 1394-DV device control to use this option.
 5. Click Finish. The selected video begins printing to the device. A progress meter appears indicating the percent completed.

Note: The tone that you can include in the leader is fixed at -20 dB. If you need a different tone level (to match your audio mix), create a test pattern and tone clip that is calibrated to your record deck.



Customizing Vegas software

You can customize Vegas® software to suit your project needs and working preferences. Many of the settings depend on your equipment or studio setup. Vegas software can be set to work with the components that you use in your studio.

In this chapter, you will find information about functions that allow you to customize the appearance of Vegas software, set a project's properties, and set the application's preferences.

Displaying frame numbers

You can display frame numbers on video events. Once you have enabled frame numbering, a small box appears at the bottom of the event thumbnail with the frame offset, time or timecode. The small black arrow marks the exact position of that frame in time.

When the workspace is zoomed in far enough, each thumbnail represents a single numbered frame in the source video file. At intermediate zoom levels, marks between the frame numbers show the location of intermediate frames. These frame marks are not visible at lower magnifications.



1. From the **Options** menu, choose **Preferences**.
2. Click the **Video** tab.
3. Choose an option from the Show source frame numbers on event thumbnails as drop-down list.
4. Click **OK**.

Changing the ruler format

You can customize the ruler to display a number of different standard formats. The format that you select affects how the ruler and time display window display time units. *For more information, see [Timecode in Vegas software](#) on page 325.*

To change the ruler's format, right-click the ruler and choose the desired time format from the shortcut menu or, from the **Options** menu, choose **Ruler Format** and choose the desired time unit. You can also change ruler settings on the Project Properties dialog's Ruler tab. *For more information, see [Ruler tab](#) on page 292.*

The following are the different time units available (hh=hours, mm=minutes, ss=seconds, and ff=frames):

Time format name	Units
Samples	numbered (starting with zero)
Time	hh:mm:ss.sss
Seconds	sssss.sss (to three decimal places)
Time & Frames	hh:mm:ss:ff
Absolute Frames	frames are numbered starting with 0
Measures & Beats	measures.beats.ticks, where 64 ticks = 1 beat
Feet & Frames 16mm (40 fpf)	feet+frames, where 40 frames = 1 foot
Feet & Frames 35mm (16 fpf)	feet+frames, where 16 frames = 1 foot
SMPTE Film Sync (24 fps)	hh:mm:ss:ff
SMPTE EBU (25 fps, Video)	hh:mm:ss:ff
SMPTE Non-Drop (29.97 fps, Video)	hh:mm:ss:ff
SMPTE Drop (29.97 fps, Video)	hh:mm:ss:ff
SMPTE 30 (30 fps, Audio)	hh:mm:ss:ff
Audio CD Time	hh:mm:ss or hh:mm:ss:ff when zoomed in tightly

Editing the ruler offset

The ruler doesn't necessarily need to start with zero at the far left side. You can enter an offset to change the orientation of the ruler in a project. One use of this is to create a lead-in into a project. A five-second offset would mean that the ruler would start at -5 seconds and would be at 0 five seconds into the project.

Note: You cannot create a ruler offset in an audio CD layout project.

1. Position the cursor at the desired location along the timeline.
2. Right-click the ruler and choose **Set Time at Cursor** from the shortcut menu. The current ruler value is highlighted.
3. Enter a time value.
4. Press **Enter** to set the ruler's time. The value that you enter at the cursor's position affects the entire ruler.

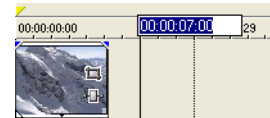

Changing grid spacing

Grid spacing is different from the ruler and provides an alternate method of subdividing a project's time. This can be useful if you want the ruler to display SMPTE video timecode, but you need to create your music in terms of beats and measures. You can display the grid spacing in time, frame, measure, or note units. The grid can also be set to match the ruler's time format. The grid appears across all tracks in your project and the grid's lines can be used as snap points.

Ruler and grid increments can be different.
This new project is set with Ruler = SMPTE non-drop and Grid = Quarter notes.

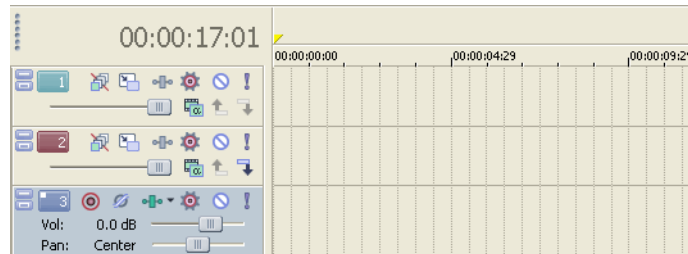

To change grid spacing, choose **Grid Spacing** from the **Options** menu, and choose the desired time unit from the submenu. The grid spacing changes to reflect your selection.

Note: In some cases, the grid lines and the ruler do not match. This is because they are two independent functions.

Using the Time Display window

The Time Display window reflects the cursor's position on the timeline and the end point of a time selection. You can customize the time display's settings, including what time the window displays and what colors it uses.

You can move the Time Display window from its docked position above the track list to float on the workspace. In addition, you can dock the time display in the window docking area. *For more information, see [Window docking area and floating window docks](#) on page 21.*

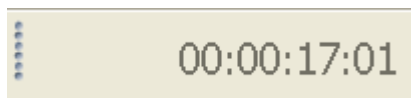

Changing the time display settings

The time display always reflects the ruler settings that are selected. You can change the ruler settings via the time display or vice versa. *For more information, see [Changing the ruler format](#) on page 287.*

1. Right-click the time display. A shortcut menu appears.
2. From the shortcut menu, choose **Time Format**, and choose the desired time format from the submenu.

Both the time display and ruler display the chosen time format.

Changing the time display colors

You can change the background color and text color used in the time display.

1. Right-click the time display to display the shortcut menu.
2. From the shortcut menu, choose **Text Color** or **Background Color** and then choose **Custom**. The Time Display Color dialog appears.
3. Choose the color setting that you want.
4. Click **OK** to set the text or background color or click **Cancel** to keep the existing color settings and close the dialog.

Tip: To return the time display's text or background color to its default settings, choose either **Text Color** or **Background Color** from the shortcut menu, and choose **Default** from the submenu.

Setting the time display to monitor MIDI timecode

You can use the time display to monitor the status of incoming or outgoing MIDI timecode. Vegas software can monitor MIDI timecode being generated from an external device or monitor MIDI timecode and MIDI clock information generated by Vegas software. From within Vegas software, the time display settings work in conjunction with your project's properties and MIDI setup options. For more information, see [Sync tab](#) on page 301.

1. Right-click the time display.
2. From the shortcut menu, choose the type of MIDI monitoring to be displayed.

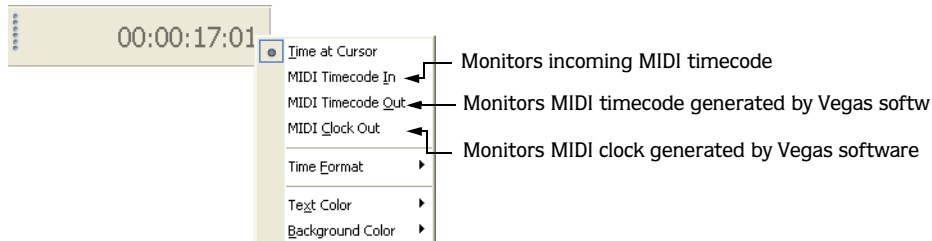

Once you have made your selection, the time display displays both the MIDI timecode being input or output and a status message.

Working with project properties

A large range of formats and various types of media files are supported. Some settings in a project's properties are simply informational details about the project, while others control how your project is handled and its output. If you have multiple projects, the settings used for each project are stored. These settings can be saved as templates for future use.

To view and modify project properties, choose **Properties** from the **File** menu. The Project Properties dialog has five tabs: Video, Audio, Ruler, Summary, and Audio CD. An overview of each tab and its settings follows.

Video tab

This tab allows you to set different characteristics the project uses to handle the video. Also, this tab displays information about the video contained in your project. For more information, see [Modifying project video properties](#) on page 201.

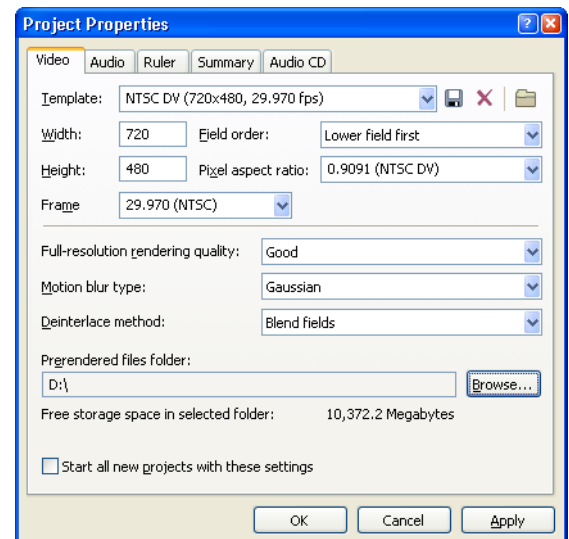

Audio tab

This tab allows you to set different characteristics the project uses to handle the audio. This page also displays the available drive space where recorded audio is stored.

Item	Description
Master bus mode	Choose Stereo to create a two-channel stereo project. Choose 5.1 Surround if you want to perform advanced 5.1-channel mixing (available only in the full version of Vegas software).
Number of stereo busses	Enter the number of stereo busses that you want in your project. You may add up to 25 additional busses. The busses appear in the Mixer.
Sample rate	Choose a sample rate from the drop-down list or enter your own rate. The sample rate range is 2,000 Hz to 96,000 Hz. Higher sample rates result in better quality sound, but also mean larger audio files.
Bit depth	Choose a bit depth from the drop-down list. A higher bit depth results in better quality sound, but also means larger audio files.
Resample quality	Choose Preview, Good, or Best resample quality.
Enable low-pass filter on LFE (surround projects only)	Applies a low-pass filter to each track in a 5.1 surround project that is assigned to the LFE channel.
Cutoff frequency for low-pass filter (Hz)	Choose a frequency to set the frequency above which audio will be ignored by the LFE channel.
Low-pass filter quality	Choose Preview, Good, or Best to determine the sharpness of the filter's rolloff curve. Best produces the sharpest curve.
Recorded files folder	Displays the path where recorded audio is stored. The Browse button allows you to select a new location to store recordings.
Free storage space in selected folder	Displays the available disk space where recorded audio is stored.
Start all new projects with these settings	Use the project properties that you have specified whenever a new project is created.

Ruler tab

This tab allows you to change ruler settings used in your project. You can also change ruler settings in track view. *For more information, see [Changing the ruler format](#) on page 287.*

Item	Description
Ruler time format	Choose a ruler time format from the drop-down list.
Ruler start time	Enter a value that the ruler will use at the beginning of your project. This feature is useful for synchronization purposes.
Beats per minute (tempo)	Enter the desired number of beats per minute for the project.
Beats per measure	Enter the desired number of beats to occur per measure for the project.
Note that gets one beat	The value entered will determine the time signature used by the ruler when its format is set to Measures and Beats. For example, if the entered value is 4, then a quarter note gets one beat.
Start all new projects with these settings	Use the project properties that you have specified whenever a new project is created.

Summary tab

This tab allows you to enter information about the project. You can leave the boxes on this tab blank or, if information exists, you can change it at any time.

Property	Description
Title	Enter the name or title of the open project.
Artist	Enter the name of the narrator, band, or artist(s) being recorded into the project.
Engineer	Enter the name(s) of the people who mixed and edited the project.
Copyright	Enter the date and ownership rights of the project.
Comments	Enter information that identifies and describes the project.
Start all new projects with these settings	Use the project properties that you have specified whenever a new project is created.

Audio CD tab

This tab allows you to enter information used when burning audio CDs.

 *CD burning is only available in the full version of Vegas software.*

Property	Description
Universal Product Code/Media Catalog Number	If your CD-R device supports writing UPC/MCN codes, you may specify the value in this field. If you leave the field blank, no UPC/MCN value will be written to the CD. Otherwise, the value consists of 13 digits.
First track number on disc	This sets the number for the first track on the disc.

Using the toolbar

The main toolbar is automatically displayed below the menu bar. However, you may hide and customize the toolbar to suit your preferences. The settings that you apply to the toolbar remain set until you change them again.

Hiding and displaying the toolbar

If you prefer to use shortcut keys when working with your project, you may hide the toolbar to create more workspace. Choose **Toolbar** from the **View** menu to hide it. The check mark next to the command is removed and the toolbar disappears. The toolbar remains hidden until you choose **Toolbar** from the **View** menu to display it again.

Reordering toolbar buttons

You can change the main toolbar's button order to suit your preferences. The Customize Toolbar dialog allows you to control the order and functionality available on the main toolbar. You may return the toolbar to its default settings by clicking the Reset button.

1. From the **Options** menu, choose **Customize Toolbar**. The Customize Toolbar dialog appears.

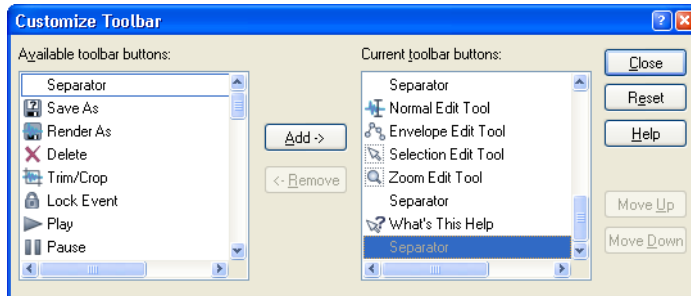

2. In the Current toolbar buttons list, select the button that you want to move and click Move Up or Move Down.
3. Click Close to save the toolbar changes and close the dialog.

Adding buttons to the toolbar

A series of buttons are included that you may add to the main toolbar. These buttons are listed in the Customize Toolbar dialog. You may also add separators on the toolbar to organize the buttons to suit your preferences.

You may return the toolbar to its default settings by clicking the Reset button on the dialog.

1. From the **Options** menu, choose **Customize Toolbar**. The Customize Toolbar dialog appears.
2. In the Available toolbar buttons list, use the scroll bars to locate the button that you want to add, and then select it.
3. On the Current toolbar buttons pane, select the button that you want the newly added button to proceed in order.
4. Click Add. The new button is added above the selected button in the Current toolbar buttons list.

Note: You may also double-click a button to add it to the toolbar.

5. Click Close to save the toolbar settings and close the dialog.

Removing buttons from the toolbar

You may remove buttons and separators from the main toolbar. If you have added buttons to the toolbar, removing unused or unwanted buttons allows you to maximize the toolbar's space.

1. From the **Options** menu, choose **Customize Toolbar**. The Customize Toolbar dialog appears.
2. On the Current toolbar buttons pane, select the button that you want to remove.
3. Click Remove. The button is removed from the Current toolbar buttons pane and will not appear on the toolbar.
4. Click Close to save the toolbar settings and exit the dialog.

Setting preferences

The preferences options are different from project properties. Project properties are unique to each project, while preferences affect how Vegas software functions. Any changes that you make to the preferences remain set until you change them again or reset Vegas software to use the default presets.

You can access the Preferences dialog by choosing **Preferences** from the **Options** menu. This dialog contains tabbed pages. The following sections explain the settings on each tab.

General tab

The General tab includes a variety of settings. The following is a list of these preferences and their meaning.

Preference	Description
Automatically open last project on startup	When Vegas software is run, the last project saved automatically opens.
Show logo splash screen on startup	Briefly shows the Vegas software logo while the program is loading. The logo does not increase loading time.
Show active take information in events	When this check box is selected, the current take information will be displayed on events in the timeline. Pitch shifted audio events will display the amount of pitch shift in the bottom-left corner of the event. If the media has a known root note, the new root is displayed in parentheses. Stretched audio events will display a percentage in the lower-right corner of the event to indicate the stretched playback rate. If the media has a known tempo, the effective playback tempo (after stretching) is listed in parentheses after the stretch amount.
Draw waveforms and frames in events	Draws a graphical representation of an audio file's waveform and thumbnail images of a video file's frames.
Show video event buttons	Shows/hides the Event FX, Pan/Crop, and Generated Media buttons on video events.
Animate video frames in Trimmer	Animates the thumbnail representations of frames in a media file opened in the Trimmer. This can visually aid trimming.
Prompt to keep files after recording	Opens a dialog where you can enter a name and select a location where audio will be saved after recording into a track.
Create undos for FX parameter changes	Allows you to undo changes made in the FX, Transition, Event Pan/Crop and Track Motion windows.
Confirm media file deletion when still in use	When deleting media in the Explorer or Media Pool, Vegas software warns you if any events in the project are using these files.
Double-click on media file loads into Trimmer instead of tracks	The default Explorer double-click behavior is to insert an event at the cursor position on the timeline. Select this option to open the media file in the Trimmer instead.
Show Trimmer history with file name first, then folder	The Trimmer history drop-down list displays the media file's name first, followed by the folder it is in. Select this to reverse the names.
Automatically save Trimmer markers and regions with media file	Markers and regions created at the media file level in the Trimmer can be saved to the file.
Show progress in Video Preview window while rendering	Frames can be displayed in the Video Preview during a render. This will slow a render somewhat.
Save active prerenders on project close	Full quality preview renders are cleaned up and deleted when a project is closed. Select this if you want these prerendered files to be available later.
Close media files when not the active application	This allows media files to be edited in external editors (audio, image, etc.) while they are contained in events.
Close audio and MIDI ports when Vegas is not the active application	Select this check box if you want Vegas software to close audio and MIDI ports when you switch to another application.
Enable multimedia keyboard support	This allows you to use a multimedia keyboard to control playback of a project.
Render large Wave files as Wave64	The WAV format is limited by a maximum file size of ~2GB. You can choose to render larger files as Wave64™ files.
Automatically name regions and markers if not playing	When regions and markers are added, this option automatically prompts you for a name. This does not happen when adding markers on-the-fly during playback.
Ignore third party DV codecs	Clear this check box to enable third-party DV codecs.
Use Microsoft DV codec	Vegas software uses the Sony Pictures Digital DV codec (which offers improved DV video quality over the Microsoft codec) as a default. Select this option to have Vegas software use the Microsoft codec to read DV files instead.

Preference	Description
Strictly conform to AVI2 specification	Select this option to create 100% AVI2 compliant files. While these files conform to the standards, not all applications follow these specifications and some programs may not be able to read them.
Disable multi-processor AVI rendering	Suspends dual processor rendering for AVI files. Selecting this option does not affect other dual processor operations.
Allow pulldown removal when opening 24p DV	Select this option to have Vegas software remove pulldown on DV video files in 24 fps progressive-scan (24p) format. When this check box is cleared, Vegas software will open 24p files as 29.97 fps interlaced video (60i).
Create project file backups (.veg-bak)	Automatically create backups of your project files.
Use Net Notify to stay informed about Sony products	Select this option to have Vegas software periodically display information from Sony Pictures Digital at startup.
Enable autosave	Creates a temporary project file that can aid in crash recovery. When enabled, autosave occurs every five minutes. The autosave process does not overwrite the original project file.
Use linear scrub range	When this check box is selected, the scrub control uses a linear range. When this check box is cleared, the scrub control uses a logarithmic range.
Allow Ctrl+drag cursor style scrub over events	Vegas software allows scrubbing on empty sections of the timeline using Ctrl+drag on the cursor. Select this option to enable timeline scrubbing over events as well.
Make spacebar and F12 Play/Pause instead of Play/Stop	Changes the spacebar and F12 keys to start and pause playback rather than start and stop.
Always draw marker lines	Select this check box if you want Vegas software to extend marker and region lines across tracks in the timeline. When the check box is cleared, marker lines are drawn only when Enable Snapping is turned on.
Build 8-bit peak files	Vegas software builds 16-bit peak files as a default. Select this option to build 8-bit peak files instead.
Disable pop-up animations	Turns off the animation applied to windows such as Video FX, Event Pan/Crop, and Track Motion when these windows are opened.
Automatically hide docking area	Select this check box if you want the window docking area to hide automatically. Hover over the bottom of the Vegas software window to show the window docking area.
Show video event edge frames in Video Preview window during edits	Select this check box if you want Vegas software to show the frame at the edge of a video event when you perform edge trimming. For example, when you drag the edge of a video event with this check box selected, the Video Preview window will update to draw the last frame in the event as you drag. When the check box is cleared, Vegas software will display a static frame.
Build peaks for visible events only	Select this check box if you want Vegas software to build peak files as needed. Vegas software will not build a peak file until a file is visible in the timeline. You can open your projects more quickly, but there may be occasional pauses as Vegas software builds peaks. Clear the check box if you want Vegas software to build all necessary peak files when you open your project. Opening a project can take longer, but after peak files are built, you can scroll through and view your project.
Keep bypassed FX running (to avoid pause on bypass/enable)	Select this check box if you want effects to remain open so you can bypass/enable effects with no pause for A/B testing. When the check box is cleared, effects are fully bypassed, conserving processing power.
Enable joystick support	Select this checkbox if you want to have joystick control for editing in Vegas software.
Enable Windows XP theme support	When this check box is selected, the Vegas window will inherit the appearance of the current theme when using Microsoft® Windows® XP. When the check box is cleared, user interface elements will maintain the classic Windows operating system appearance.
Allow edit cursor to be dragged	Select this check box if you want to be able to drag the cursor to change its position on the timeline and in the Trimmer window. When this check box is selected, you can position the cursor without losing your loop region To create a time selection without moving the cursor, hold the Shift key.
Recently used project list	Select the number of files to be listed at the bottom of the File menu.
Temporary files folder	Select a location for all temporary files.
Free storage space in selected folder	Displays the available disk space in the folder specified in the Temporary files folder box.
Default All	Restores all general preferences to the default settings.

Video tab

The Video tab in the Preferences dialog controls the display of video media, video events and video tracks.

Preference	Description
Dynamic RAM Preview max	Determines the size of the RAM cache for building dynamic RAM previews in the Video Preview window. Dynamic RAM previews are only available in the full version of Vegas software. For more information, see Building dynamic RAM previews on page 256.
Show source frame numbers on event thumbnails as	Display frame, time, or timecode numbering on video event thumbnails.
Preferred video capture application	Browse for the application to be launched when you click the Open Video Capture button ().
Action safe area and Title safe area	Sets the reference overlay safe areas in the Video Preview window. For more information, see Identifying safe areas on page 258.
Horizontal Grid Divisions and Vertical Grid Divisions	Sets the spacing of the grid overlay in the Video Preview window used in aligning visual elements in a project. For more information, see Changing grid spacing on page 289.
Display at project size	Sets the Video Preview window to always display the video at full project size.
Simulate device aspect ratio	Determines how the video is displayed in the Video Preview window. In short, televisions display rectangular pixels and computer monitors display square pixels. This can result in a distorted preview, although the source media and rendered video is unaffected.
Background color	Sets the background color of the Video Preview window (black by default) that shows either when there is no visual content or when using a transparent overlay with no background visual content.
Default track fade colors	Sets the default top and bottom colors when adding a Fade to Color envelope to a video track. For more information, see Working with track envelopes on page 126.
Default All	Restores all video preferences to the default settings.

Video device tab

This tab allows you to identify an external video device for Vegas software to communicate with. The selected video device is used to display previews on an external monitor or to print directly from the timeline to DV tape. *For more information, see [Printing to DV tape](#) on page 284.*

The connection between Vegas software and the video device works with OHCI compliant IEEE-1394 DV capture cards and some MJPEG capture cards. There are two cases where Vegas software can play back to an external monitor. One is when you have special hardware that has both computer and television monitor outputs. The other is for (OHCI compliant) DV capture cards where DV data can be previewed out through your DV camcorder to an external monitor. *For more information, see [Using an external monitor](#) on page 266.*

Preference	Description
Device	Choose a device from the drop-down list.
Details	Displays information regarding the capture card specified in the Device drop-down list.
If project is invalid for DV output, conform to the following	If your source media does not conform to DV standards, choose a setting from the drop-down list to adjust the video to display properly on your external monitor.
Sync offset (frames)	If audio and video do not play back in synchronization on your external monitor, drag this slider to specify a frame offset to restore synchronization. Note: This setting affects synchronization on an external monitor only. Audio and video synchronization in your Vegas project is unaffected.
Record engage delay (frames)	Drag the slider to specify the number of frames it takes your camcorder or deck to switch from Record Pause to Record mode. If you're missing frames from the beginning of your file after printing to tape, increase the setting. If you see duplicated frames at the beginning of your video, decrease the setting.
Recompress edited frames	When this check box is selected, Vegas software will recompress any edited frames in your project before previewing.
Default All	Restores all video device preferences to the default settings.

Audio tab

The Audio tab allows you to set preferences to optimize how your computer's components are used to handle resource-intensive audio. This tab also allows you to configure Vegas software to the equipment that is connected to your computer.



Multiple audio busses are only available in the full version of Vegas software.

Preference	Description
Waveform display while recording	Allows you to display or hide waveforms when recording into an audio track.
Normalize peak level (dB)	Sets the maximum level that is used when normalizing an event.
Import audio at project tempo	When this check box is selected, ACID loops are automatically stretched to match the project tempo (specified on the Ruler tab of the Project Properties dialog) when you add them to the timeline or preview from the Explorer window. When the check box is cleared, tempo information is ignored.
Preferred audio editor	Displays the path of the audio editor that you can start directly from Vegas software to perform destructive edits to audio.
Metronome	Allows you to use a default metronome sound or to select custom sound files to be used as the metronome beats.
Default All	Restores all audio preferences to the default settings.

Audio Device tab

Preference	Description
Audio device type	Choose a driver type from the drop-down list. The Microsoft Sound Mapper is the default setting. If you want to activate specific sound cards, choose Windows Classic Wave Driver or ASIO and choose a device from the Default Stereo and Front playback device drop-down list. ASIO audio drivers are only supported in the full version of Vegas software. For more information, see Routing busses to hardware on page 147.
Default Stereo and Front playback device	Choose the device that you want to use for playing stereo sound data and the front-left and -right channels of a 5.1 surround project. Selecting the Microsoft Sound Mapper allows Windows to select an appropriate device to use for the current sound data. Note: If you have selected Microsoft Sound Mapper, you will not be able to assign busses to different devices.
Default Rear playback device	Choose the device that you want to use for playing the rear channels of a 5.1 surround project.
Default Center and LFE playback device	Choose the device that you want to use for playing the center and low-frequency effect channels of a 5.1 surround project.
Playback buffering (seconds)	Sets the amount of memory used during project playback. For more information, see Adjusting the playback buffering slider on page 298.
Default audio recording device	Sets the default device for recording into a track.
Automatically detect and offset for hardware recording latency	Select the check box to automatically compensate for offset between the time you initiate recording and when your sound card starts recording. Clear the check box and drag the User recording latency offset (ms) slider to specify an offset value.
Default All	Restores all audio device preferences to the default settings.

Advanced audio preferences

You can access advanced settings by clicking the **Advanced** button on the **Audio Device** tab. The **Advanced Audio Configuration** dialog displays all of the audio devices that are installed on your computer and allows you to set the controls for each device.

Preference	Description
Audio devices	This list contains all of the audio devices that are installed in your computer. Selecting one from the list allows you to set the options below for that device.
Interpolate position	During project playback, you may notice that the cursor position is different than what you are hearing. This problem stems from inaccuracies in some audio devices. Select this control's check box to have Vegas software attempt to compensate for the inaccuracies by interpolating the cursor's correct position during playback or recording.
Position bias	The position bias control gives you additional cursor control when it is inaccurately displayed during project playback and recording. If you have enabled the Interpolate position control and are still experiencing cursor position inaccuracies, move the Position bias control forward or backward to compensate for the inaccuracies of the audio device.
Do not pre-roll buffers before starting playback	When this option is not selected, Vegas software begins storing (buffering) project audio information prior to playback. This storing is very fast and unnoticeable in most cases. However, some audio devices stutter when you begin playback as a result of the buffering process. If your audio stutters when you start playback, select this check box to prevent buffering audio information prior to playback.
Audio buffers	Drag the slider to set the number of audio buffers that will be used. Adjusting this setting can help you synchronize the input and output for record input monitoring. Record input monitoring is only available in the full version of Vegas software.
Buffer size (samples)	Choose a setting from the drop-down list to indicate the buffer size you want to use. Choose MME to use the Playback buffering setting on the Audio Device tab in the Preferences dialog.
Priority	Choose a setting from the drop-down list to set the priority that is assigned to your audio buffers. Increasing the buffers' priority can help you attain smoother playback, but it can also adversely affect other processes.
Enable input monitoring	Select this check box to enable the monitoring of your recording input through Vegas software while you are recording.

Adjusting the playback buffering slider

The playback buffer controls how much memory is used when playing back your project. This preference is useful, but must be carefully adjusted. If you set the buffer size too high, you may experience gapping during playback. Conversely, if you set the buffer size too low, you may experience gapping as well because Vegas software has too little memory to work with during playback.

The playback buffer slider should be set to balance RAM usage and playback buffering. The rule is to set this slider as low as possible without introducing gapping.

1. Open a project that has multiple events.
2. On the **Audio device** tab, move the **Playback buffering (seconds)** slider to 0.25.



3. Start playing back the project.
4. If the playback still gaps, increase the **Playback buffering (seconds)** slightly.

You may have to experiment to find the correct settings. If you continue to experience gapping, you can try the following to control the gapping:

- Decrease the number of events you are trying to play back. This may mean muting tracks or soloing a couple of tracks. RAM is mostly affected by the number of unique events that are playing back simultaneously.
- Use the **Render to New Track** command (on the **Tools** menu) to combine all the events into one event. For more information, see [Rendering to a new track](#) on page 116.

MIDI Tab

Use the MIDI tab to set options for using MIDI devices with Vegas software. To display this tab, choose Preferences from the Options menu, then click the MIDI tab.

Preference	Description
Make these devices available for MIDI output	Select the check box for each MIDI device that you want to use as a MIDI output for a control surface.
Make these devices available for MIDI input	Select the check box for each MIDI device that you want to be available for a control surface.
Default All	Restores all MIDI preferences to the default settings.

Editing tab

Preference	Description
Enable looping on events by default	Sets events that are trimmed longer than their source media to automatically loop. When this option is not selected, extended events repeat the final frame of a video file.
Preserve pitch when stretching audio events	Prevents pitch shifting when you stretch an audio event.
Collapse loop region when no time selection is present	When selected, a loop region does not persist when there is no time selection. This means that when you click the timeline and move the cursor (destroying the any previous time selection), the loop region is also reset to zero. By default, this option is not selected and loop regions persist until modified or until a new time selection is created.
JKL/shuttle speed	Choose a setting from the drop-down list to set the speed that will be used for scrubbing the timeline with the JKL keys or with a multimedia controller.
Quick fade length for audio events (ms)	Sets a fast fade on the edges of audio events (10ms by default) to soften potentially harsh beginnings and endings.
New still image length (seconds)	Sets the default duration of inserted still image files (e.g., BMP, PNG).
Default time between CD tracks	Sets the default time created between CD tracks when using the Add Media as CD Tracks command in the Media Pool window. For more information, see Adding media as CD tracks to a new project on page 307.
Cursor preview duration (seconds)	Enter a value in the edit box to specify the length of the time Vegas software will preview when you preview the cursor. To preview the cursor, press the 0 key on the numeric keypad. Vegas software creates a temporary selection (centered over the cursor) and begins playback automatically. Cursor preview will loop if the Loop Playback mode is enabled.
Automatically overlap multiple selected media when added	Creates automatic crossfades between events when multiple media files are added to the same track across time. When this check box is not selected, multiple media files are added end-to-end across time with no overlap. For more information, see Creating a slide show on page 191.
Cut to overlap conversion	Sets the behavior of the cut-to-overlap feature. The cut-to-overlap feature allows you to transform a cut from one event to another into a transition. The Amount field sets the duration of the extended overlap. The Alignment value determines the direction of the extension. For more information, see Converting a cut to a transition on page 234.
Envelope fade types	Sets the default fade curves for event, track, and bus track envelopes. You can choose separate fade types for audio and video envelopes. For more information, see Changing an event's fade curve on page 138.
Default All	Restores all editing preferences to the default settings.

Display tab

Preference	Description
Track colors	Use these controls to change the default colors used to display tracks in your project. Select a track from the Track drop-down list, and then click the color swatch to display a color picker. You can choose any color using the RGBA or HSLA controls, or click the eyedropper to sample a color from your screen. When you click OK or Apply, all tracks that used the selected color are updated.
Envelope Colors	Choose an envelope type from the Envelope color preference for drop-down list and click the color swatch to display a color picker, where you can choose any color using the RGBA or HSLA controls, or click the eyedropper to sample a color from your screen.
Icon color saturation	Drag the slider to adjust the color intensity of icons in the Vegas window. Drag to the left to decrease the color saturation, or drag to the right to increase it.
Icon color tint	Drag the slider to adjust the amount of tinting that is applied to the icons in the Vegas window. Drag the slider to the right to add an average of the title bar colors to the icons. Drag to the left to decrease the amount of tinting applied.

CD Settings tab

The CD Settings tab allows you to set preferences for burning CDs and extracting audio from your own CDs.

 *CD burning is only available in the full version of Vegas software.*

Preference	Description
Burn drive	Sets the device where you burn CD-R discs.
Burn speed	Sets the speed at which the device burns the CD-R disc.
Extract optimization	Sets the amount of buffering and restitching done to recover audio from older CD drives. Adjust this setting if your extracted CD audio has occasional gaps or glitches.
Autoname extracted tracks	Automatically names extracted CD tracks based on the ISRC number, the track number, and the number of times the track has been extracted.
Use strict Red Book specification for DAO validation	Select this check box if you want to be notified prior to burning a disc-at-once CD if anything about your CD project is against strict Red Book standards. These warnings are not critical, and in most cases you will not write an unreadable disc if you proceed. Clearing this check box will not suppress critical warnings that will result in an unreadable disc.
Include wide SCSI devices when searching for drives	Select this check box if you want Vegas software to scan for wide SCSI CD drives when you attempt to extract data from or burn CDs. When the check box is cleared, Vegas software will not scan for wide SCSI devices, which can increase compatibility with some USB device drivers that incorrectly identify themselves as wide SCSI.
Skip drive database; autodetect drive capabilities on startup	When the check box is cleared, Vegas software will use an internal configuration file to determine your drive's capabilities. If you encounter problems burning CDs, select this check box, and Vegas software will test your drive to determine its capabilities.
Default All	Restores all CD preferences to the default settings.

Sync tab

These preferences are used to set up Vegas software to generate or trigger from MIDI timecode from external MIDI devices. For more information, see [Synchronizing MIDI timecode](#) on page 164.

Preference	Description
Generate MIDI Timecode settings	Sets the output device and frame rate used when generating MIDI timecode.
Generate MIDI Clock settings	Sets the output device used when generating MIDI Clock information. You can choose the same device that you chose for Generate MIDI Timecode settings .
Trigger from MIDI Timecode settings	Sets the input software or device and frame rate used when triggering from MIDI timecode.

Note: When Sync is active (Vegas software is triggering from MTC), media files are not closed (i.e., cannot be edited outside of Vegas software) when Vegas software is not the active application. You will also not be prompted to rename or delete recorded takes as this may interrupt the synchronization.

Setting advanced Sync preferences

From the Sync tab, you can access advanced settings by clicking Advanced. The Advanced Sync Preferences dialog has three tabs: MTC Input, MTC Output, and MIDI Clock Output. The display of these tabs is dependent on your selections in the Sync tab. See the following sections on each tab for more information.

MTC Input

This tab displays only if you choose a device in the Trigger from MIDI Timecodes settings drop-down list on the Sync tab.

Preference	Description
Free-wheel for timecode loss	When selected, Vegas software continues to play for a specified period of time without chasing if timecode is lost. Enabling this option can compensate for infrequent losses in timecode monitoring. If losses in timecode are frequent, troubleshooting should be done on your hardware to find the cause of the problem.
Free-wheel slack time (seconds)	Specifies the amount of time that timecode can be lost before the Free-wheel playback time starts. A longer time is more tolerant of losses in the incoming timecode.
Free-wheel playback time (seconds)	Specifies the amount of time that Vegas software plays back after the Free-wheel slack time has been exceeded.
Synchronization delay time (seconds)	Specifies the amount of time required for Vegas software to synchronize itself to incoming timecode. On slower computers, this time should be set to around two seconds. On faster computers, it may be set lower.
Offset adjust (quarter frames)	If Vegas software is consistently behind or ahead of the MTC generator, enter a value to adjust a synchronization offset with quarter-frame accuracy. If Vegas software is behind the MTC generator, enter a negative number such as -4. If Vegas software is ahead of the MTC generator, enter a positive number such as 4.

MTC Output

This tab displays only if you choose a device in the Generate MIDI Timecode settings drop-down list on the Sync tab.

Preference	Description
Full-frame message generation	Specifies when Vegas software sends full-frame timecode messages. Full-frame messages are used by some external audio synchronizers to seek a proper location prior to synchronization. For example, tape-based recorders benefit from seeking to full-frame messages because of the time required to move the transport to the proper location. However, full-frame messages are ignored by some devices and may actually cause unexpected behavior in other devices. Check your hardware documentation to find out if it supports full-frame messages.

MIDI Clock Output

This tab displays only if you choose a device in the Generate MIDI Clock Settings drop-down list on the Sync tab.

Preference	Description
Send Start instead of Continue when beginning playback	When selected, Vegas software sends a Start command rather than a Continue command. Normally, Vegas software sends a Continue command to allow the chasing device to start at a specific time. However, some older MIDI sequencers do not support the Continue command and must start from the beginning every time.
Song Position Pointer generation	Specifies when Vegas software sends Song Position Pointer messages. Song Position Pointer messages are used by MIDI applications and devices to seek to a proper location prior to starting the synchronization process.

Keyboard tab

From the Options menu, choose Preferences and select the Keyboard tab to customize the keyboard shortcuts available in the Vegas interface.

The Current Key Bindings box displays the currently assigned shortcut keys. Choose a setting from the Context drop-down list to choose which shortcuts you want to see.

Editing shortcuts

1. Select a command in the Available commands box.

Choose **Global** from the Context drop-down list to display all commands in the Available commands box, or choose a different command to filter the list.

You can type a word in the Show only commands containing box to filter the list of commands to display only commands that contain the word you typed.

2. Click the Press new shortcut keys box and press the key combination you want to assign to the selected command.
3. Click the Assign button to assign the key combination in the Press new shortcut keys box to the command selected in the Available commands box.

Importing a keyboard map

Click the Import button and browse to a Vegas Keyboard Map File (.ini) file to load an existing keyboard map.

Exporting a keyboard map

Click the Export button and specify a file name and location to save your current keyboard shortcuts to a file that you can use as a backup or to share your keyboard shortcuts with other Vegas users.

Resetting the default keyboard map

Click the Default All button to restore the default configuration.

External Control & Automation tab

Use the External Control and Automation tab to set up and customize control surfaces. To display this tab, choose **Preferences** from the **Options** menu, then click the External Control & Automation tab.

Preference	Description
Smooth and thin automation data after recording	When recording automation, Vegas software creates as many envelope points or keyframes as possible to represent your control movements. Select this check box if you want to reduce the number of envelope points/keyframes after recording is finished. For more information, see Recording automation settings on page 130.
Set controls to default values when automation is turned off	Select this check box if you want controls to return to their default values when set the track's automation recording mode to Automation Off. Automated effect parameters do not have default settings and will retain their last-set values when you turn automation off. When the check box is cleared, controls will retain their last-set values when you turn automation off.
Available devices	Choose a device from the drop-down list and click Add to choose the control surfaces that will be available to Vegas software. Adding a device loads its default profile.
Active control devices	Lists the control devices that you've added. Double-click a device name to customize its behavior.
Default all	Restores all control surface preferences to the default settings.

Connecting a control surface

You can use one Mackie® Control Universal or up to five generic control surfaces with Vegas software. Perform the following steps for each device.

1. Connect the MIDI Out port on your MIDI interface to the MIDI In port on your control surface.
2. Connect the MIDI In port on your MIDI interface to the MIDI Out port on your control surface.
3. Configure Vegas software to use your control surface
4. Use the MIDI tab in the Preferences dialog to select the device to which your control surface is connected. *For more information, see [MIDI Tab](#) on page 299.*
5. Add your device on the External Control & Automation tab.

Note: *For information about your specific device, please refer to the manufacturer's documentation.*

Configuring a Mackie Control Universal

The Mackie Control Universal is fully supported by Vegas software. An overlay is available from Mackie that you can use to label the buttons and controls with their mapped functions in Vegas software.

The overlay identifies the default control mapping. You can also customize the buttons and controls on the Mackie Control Universal. When you use the default mapping, the Mackie Control is divided into several functional areas.

1. From the **Options** menu, choose **Preferences** to display the Preferences dialog.
2. Select the External Control & Automation tab.
3. Double-click your Mackie Control Universal in the Active devices list to display the Configure Mackie Control dialog.
4. To add or change a function do the following:
 - a. Select an item in the User defined surface control mappings list.
 - b. Select an item in the Available host functions list.
 - c. Click the Assign button.

5. To remove a function, select an item in the User defined surface control mappings list and click the Clear button.
6. To remove all functions, click the Clear All button.
7. To replace all custom functions with the default settings, click the Default All button.

Configuring a generic MIDI controller

If you have a MIDI control surface, you can configure it to work with the Vegas interface.

1. From the **Options** menu, choose **Preferences** to display the Preferences dialog.
2. Select the External Control & Automation tab.
3. Double-click the Generic Control entry in the Active control devices list to display the Configure Generic Control dialog.
4. To load a configuration from a file, click the Open button and browse to the mapping file you want to use.
5. To add or change a function do the following:
 - a. Choose a setting from the View function group drop-down list.
 - b. Select the Learn check box.
 - c. Select an command in the Host Command list and activate the control on your control surface.
 - d. You can click the Edit button to fine-tune the MIDI message settings.
6. Repeat steps 3 and 4 for each command you want to make available on your control surface.
7. To remove a function, select an item in the Host Command list and click the Reset button.
8. To remove all functions, click the Reset All button.
9. Click the Save As button to save your updated configuration file.



Burning CDs

You created your project in Vegas® software, and now you are ready to write the project to a CD. With the CD-burning capabilities of Vegas software, you can place and arrange audio files to produce professional audio CDs. You can burn CDs for multiple- or single-track projects and build audio CD layouts automatically or manually. You can also create video CDs that can be played in many home DVD players and on computers with a CD-ROM drive and VCD player software, and multimedia CDs that can be played in any computer with the appropriate player.



CD burning is only available in the full version of Vegas software.

Understanding track-at-once and disc-at-once

Two ways are provided for recording audio to a CD-R disc: track-at-once and disc-at-once.

Track-at-once

Track-at-once writing records individual tracks to the disc and results in a partially recorded disc. However, the CD-R disc remains unplayable on most systems until you close the disc. The advantage of track-at-once writing is that you can record tracks onto the disc as you finish them versus waiting until you have finished your whole album. Track-at-once writing burns the entire project as a single track.

Disc-at-once (Single Session or Red Book)

Disc-at-once writing is the most common burning method in the music industry. This writing mode is used when creating a master disc to be sent to a disc manufacturer for mass replication. Disc-at-once works just as it sounds. Multiple tracks of audio are written to the CD in one recording session.

Understanding tracks and indices

You are ready to burn a CD. If you plan to use track-at-once to record a single track, you can proceed right on to writing the entire project to a CD. However, you are more likely to set up tracks—and perhaps indices—within your project and burn several tracks at once.

Tracks distinguish songs in the project and have a starting and ending point. Tracks are used to indicate to the CD-R device where to mark the beginning and ending of a track during the writing process.

Indices are single markers that subdivide a track. Indices are useful for navigating to specific areas within a track. For example, a sound effects CD may have one track of breaking glass. The track is then indexed to allow navigation to a specific glass-breaking effect within the track. However, be aware that not all CD players allow navigation to indices.

Tracks and indices are identified in a **track list**, which is a chronological text list of all tracks and indices defined in the audio CD project.

Setting up to burn audio CDs

 CD burning is only available in the full version of Vegas software.

You can set the project properties and adjust preferences to better accommodate writing audio CDs. The ruler and time display are set up for you automatically.

Viewing the ruler and time display

The ruler and time display are automatically changed to audio CD time for you when you mark CD tracks in a project.

Audio CD time formats are as follows:

Display	Format
Ruler	hh:mm:ss (hours:minutes:seconds) or hh:mm:ss:ff (hours:minutes:seconds:frames, with fps=75) when zoomed in tightly
Time display	tt+mm:ss:ff (track number +/- minutes:seconds:frames, with fps=75)

Setting project properties

Click the Properties button () to access project properties. On the Audio CD tab, you can set the Universal Product Code/Media Catalog Number (UPC/MCN) or set the number for the first track on the CD. For more information, see [Audio CD tab](#) on page 292.

Setting preferences

From the **Options** menu, choose **Preferences** to access the Preferences dialog. On the CD Settings tab, you can select the CD drive or set the speed at which you will burn the CD. For more information, see [CD Settings tab](#) on page 300.

You can also enter the number of seconds added between tracks when adding Media Pool files as CD tracks. In the same Preferences dialog, click the Editing tab, and enter a value in the Default time between CD tracks box.

Finally, you may want to turn off the **Quantize to Frames** command in the **Options** menu. When quantizing to frames is active, your edits are limited to the starting edge of frame boundaries. In a CD layout project, you can turn this feature off to allow greater precision in editing and track placement. For more information, see [Quantizing to frames](#) on page 89.

Importing CD Architect files

You can use Vegas software to open projects created in CD Architect™ version 4.0 software.

1. From the **File** menu, choose **Open**. The Open dialog appears.
2. Browse to the location of the project file.
3. In the Files of type drop-down list, select CD Architect Project Files (.cdp).
4. Select the file.
5. Click Open.

Creating audio CD layout projects

Several ways are provided to create an audio CD layout project. If you have a set of audio files you wish to burn to a CD, you can add the files as tracks to a new audio CD layout project. Or, if you want to burn an audio CD from an existing project, you can mark the tracks in your project either automatically or manually.

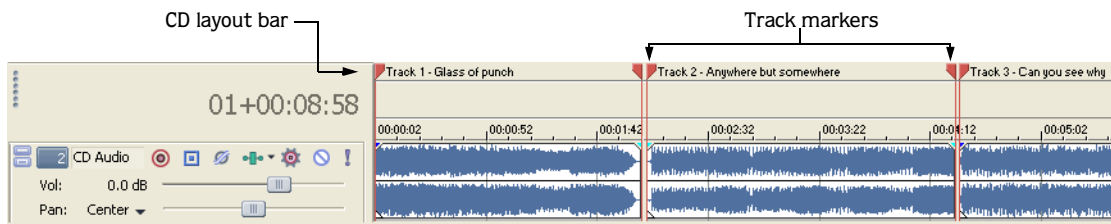

Adding media as CD tracks to a new project

You have a collection of completed audio files that you want to write to a CD. An audio CD layout project can quickly be assembled from sound files in the Media Pool. You can add the tracks one at a time, or use the Media Pool to sort them into track order and add them all at once.

1. Create a new project.
2. Add all the media to be included in the project to the Media Pool. *For more information, see [Adding media to the Media Pool](#) on page 41.*
3. To add all tracks at once, use the following steps to sort the files into track order:
 - In the Media Pool, click the arrow on the Views button () and choose **Details** from the menu. The Media Pool changes to Details view.
 - In the Comments column, enter the track number for each media file (01, 02, etc.).
 - Click the Comments column header to sort the list into track order.
 - Select the sorted files in the Media Pool.
4. Right-click a media file (or the selected media files) and choose **Add as CD Track** from the shortcut menu.

The files are added to a new track and the audio CD tracks are marked on the CD layout bar. The name of the media file is used to name each track. If necessary, you can edit the information for the new audio CD tracks using the markers on the CD layout bar or using the Edit Details window. *For more information, see [Working with tracks and indices](#) on page 309.*

Right-click files in the Media Pool to add them as CD tracks to an audio CD layout project.

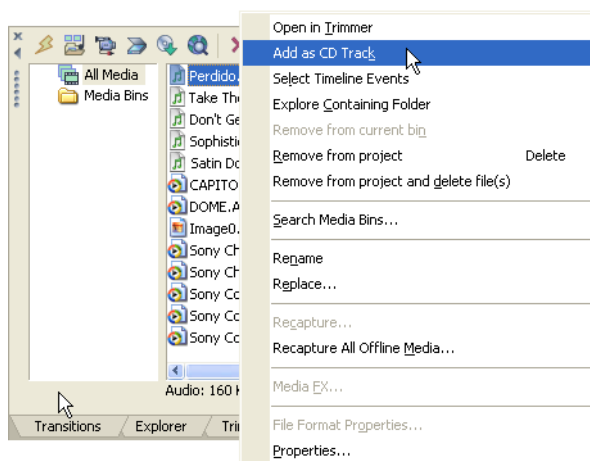

Marking tracks in an existing project

Once you have laid out your audio project with the appropriate pauses, you can mark tracks and indices either automatically or manually.

Note: In DAO CD burning, Vegas software burns from the beginning of the timeline to the last track marker, regardless of the location of the first track marker. Material before the first marker is included as a hidden track on the disc (if your drive supports burning this material).

Adding pauses

Each audio CD track in your project should have a two-second pause following it. This default setting is based on the Red Book specification for audio CDs. The exception to this standard is a continuous recording, such as a live concert CD. For a continuous recording, you can omit the pauses after tracks for continuous playback. For more information, see [Red Book specification](#) on page 335.

Note: The Red Book specification also requires a two-second pause at the beginning of an audio CD. If the first track in your project begins before the two-second mark, a ruler is added offset to ensure the project begins with the required two-second pause.

If you use the **Add as CD Track** command to add tracks from the Media Pool, the appropriate pauses are added automatically. However, if you are laying out your project manually, you must create these pauses between audio CD tracks.

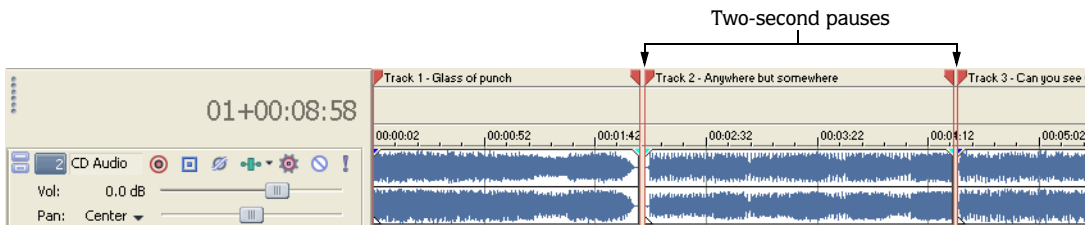

1. Position the cursor where you want to insert the pause.
2. From the **Insert** menu, choose **Time**. The Insert Time dialog appears.
3. Enter two seconds in the Amount of time to insert box.
4. Click **OK**. Two seconds are inserted in the timeline at the cursor position.

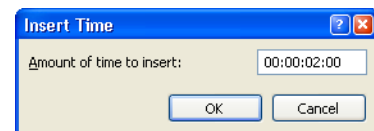

Marking tracks automatically

Vegas software can examine the events in your project and mark the audio CD tracks for you. Once the tracks are marked, you can adjust them manually if necessary. For more information, see [Moving track and index markers](#) on page 309.

1. Lay out your project with two-second pauses between tracks.
2. From the **Tools** menu, choose **Lay Out Audio CD from Events**.

The new audio CD track markers appear on the CD layout bar above the timeline. The name of the media file for each event is used to name the tracks.

Marking tracks manually

You can make a time selection and then mark that selection as an audio CD track.

1. Make a time selection that includes the audio for the new track.
2. From the **Insert** menu, choose **Audio CD Track Region**. The markers for the new audio CD track appear on the CD layout bar.

Marking indices

You can create an index marker in much the same way as you create track markers.

1. Position the cursor where you want the index mark to appear.
2. From the **Insert** menu, choose **Audio CD Track Index**. The new index marker appears on the CD layout bar.

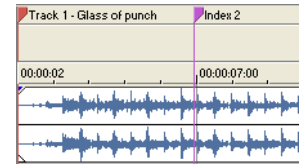

Working with tracks and indices

Once you have marked your tracks and indices, you can edit, move, rename, or delete them as needed.

Navigating to and selecting tracks and indices

Several shortcuts are provided for navigating to and selecting audio CD tracks on the CD layout bar.

- Double-click a track marker to select the track.
- Press **.** (period) to jump the cursor to the next track or index marker.
- Press **,** (comma) to jump the cursor to the previous track or index marker.
- Press **Ctrl** + **.** (period) to jump the cursor to the next track marker (index markers are skipped).
- Press **Ctrl** + **,** (comma) to jump the cursor to the previous track marker (index markers are skipped).
- Add **Shift** to any of these keystrokes to select rather than jump. For example, press **Ctrl** + **Shift** + **.** (period) to select from the cursor position to the next track marker.

The shortcut keystrokes can be used to jump the cursor while working on a project or during playback.

Moving track and index markers

Track and index markers function just like markers and regions in Vegas software (pg. 78). You can drag a track or index marker to move it along the CD layout bar. Alternately, you can use the Edit Details window to make precise adjustments.

*Tip: Move both the starting and ending markers for a track by pressing **Alt** and dragging either of the markers.*

Renaming track and index markers

1. Right-click a marker and choose **Rename** from the shortcut menu that appears.
2. Type a new name for the marker and press **Enter**.

Deleting track and index markers

You can delete a single track or index marker by right-clicking it and choosing **Delete** from the shortcut menu. To delete all markers at once, right-click the CD layout bar and choose **Delete All** from the shortcut menu.

Editing markers using the Edit Details window

The Edit Details window provides a way to adjust the settings for a track or index.

1. From the **View** menu, choose **Edit Details**. The Edit Details window displays.
2. From the Show drop-down list, choose **Audio CD Track List**. The track settings display.
3. Double-click a setting to edit it:
 - In the Position column, adjust the track starting position or index position.
 - In the End column, adjust the track ending position.
 - In the Length column, adjust the track length.
 - In the Name column, enter the name of the track or index.
 - In the Prot column, select the check box to apply copy protection to the track.
 - In the Emph column, select the check box to enable a simple noise reduction process that is implemented by a CD player. *For more information, see [Emphasis](#) on page 330.*
 - In the ISRC column, enter the ISRC number for the track (if used).

Copying a track list from the Edit Details window

You can use the Edit Details window to copy your track list and paste it into another application.

1. Click the gray box in the upper-left corner of the Edit Details window to select all the cells.
2. Press **Ctrl**+**C** to copy the cells.
3. Switch to another application and paste the information into a document or spreadsheet.

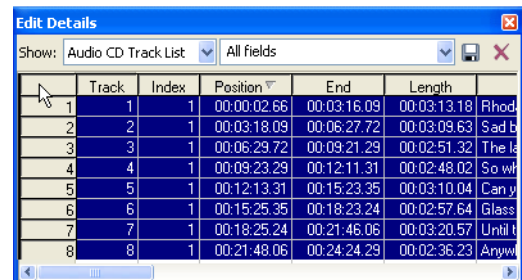

Track	Index	Position	End	Length	Name
1	1	00:00:02.66	00:03:16.09	00:03:13.18	Rhod
2	2	00:03:18.09	00:06:27.72	00:03:09.63	Sad b
3	3	00:06:29.72	00:09:21.29	00:02:51.32	The l
4	4	00:09:23.29	00:12:11.31	00:02:48.02	So wif
5	5	00:12:13.31	00:15:23.35	00:03:10.04	Can y
6	6	00:15:25.35	00:18:23.24	00:02:57.64	Glass
7	7	00:18:25.24	00:21:46.06	00:03:20.57	Until t
8	8	00:21:48.06	00:24:24.29	00:02:36.23	Anyw

Burning audio CDs

 *CD burning is only available in the full version of Vegas software.*

You can burn either single tracks (track-at-once) or the entire disc (disc-at-once).

Burning single tracks (track-at-once)

You can burn your Vegas project as a single track (track-at-once). Once you have burned all your tracks to the CD, you must close the disc before it can be played.

Burning a track-at-once CD

1. From the **Tools** menu, choose **Burn CD**, and choose **Track-at-Once Audio CD** from the submenu. The Burn Track-at-Once Audio CD dialog displays the length of the current file and the amount of time remaining on the disc in your CD recorder.
2. Choose a setting from the Action drop-down list:
 - **Burn audio** begins recording audio to your CD when you click the Start button. You will need to close the disc before it can be played in an audio CD player.
 - **Test, then burn audio** performs a test to determine whether your files can be written to the CD recorder without encountering buffer underruns. Recording begins after the test if it is successful.
 - **Test only** performs a test to determine whether your files can be written to the CD without encountering buffer underruns. No audio is recorded to the CD.
 - **Close disc** closes your disc without adding any audio when you click the Start button. Closing a disc allows your files to be played on an audio CD player.
 - **Erase RW disc** erases your rewritable CD when you click the Start button.

3. Select your burning options:

- Erase RW disc before burning: If you're using a rewritable CD, select this check box to erase the CD before you begin burning.
- Close disc when done burning: Select this check box to close the CD after burning. Closing a disc allows your files to be played on an audio CD player.
- Eject disc when done: Select this check box to eject the CD automatically when burning has completed.
- Burn loop region only: Select this check box to burn only the audio within the loop region.

4. From the Drive drop-down list, choose the CD drive that you want to use to burn your CD.

5. From the Speed drop-down list, choose the speed at which you want to burn. **Max** will use your drive's fastest possible speed; decrease the setting if you have difficulty burning.

6. Click the Start button.

Warning: Clicking the Cancel button after the disc-writing process has begun will render your disc unusable.

7. When the writing process is complete, a confirmation message displays. Click OK to clear the message.

Closing a track-at-once CD

1. From the **Tools** menu, choose **Burn CD**, and choose **Track-at-Once Audio CD** from the submenu. The Create CD dialog appears.
2. Click the Close Disc button.
3. When the disc is closed, a confirmation message displays. Click OK to clear the message.

Burning a disc (disc-at-once)

1. From the **Tools** menu, choose **Burn CD**, and choose **Disc-at-Once Audio CD** from the submenu. The Burn Disc-at-Once Audio CD dialog appears
2. From the Drive drop-down list, use the CD drive that you want to use to burn your CD.
3. From the Speed drop-down list, choose the speed at which you want to burn. **Max** will use your drive's fastest possible speed; decrease the setting to prevent the possibility of buffer underruns.
4. Select the Buffer underrun protection check box if your CD recorder supports buffer underrun protection. Buffer underrun protection allows a CD recorder to stop and resume burning.

Note: Buffer underrun protection can create a disc that can be played in CD players, but may contain a bit error where burning stopped and restarted. Consider clearing this check box when creating a premaster disc.

5. Choose a radio button in the Burn mode box:

- Burn CDs begins recording audio to your CD immediately.
- Test first, then burn CDs performs a test to determine whether your files can be written to the CD recorder without encountering buffer underruns. No audio is recorded to the CD during the test, and recording begins after the test if it is successful.
- Test only (do not burn CDs) performs a test to determine whether your files can be written to the CD recorder without encountering buffer underruns. No audio is recorded to the CD.

6. Select the Render temporary image before burning check box if you want to render your CD project to a temporary file before recording. Prerendering can prevent buffer underruns if you have a complex project that cannot be rendered and burned in real time.

Note: *The rendered temporary file will remain until you modify your project or exit. If an image file exists when you Open the Burn Disc-at-Once Audio CD dialog, the check box is displayed as Use existing rendered temporary image.*

7. Select the Automatically erase rewritable discs check box if you're burning to rewritable media and want to erase the disc before burning.
8. Select the Eject when done check box if you want the CD to eject automatically when burning has completed.
9. Click OK to start burning.

Burning video CDs

 CD burning is only available in the full version of Vegas software.

Video CDs can be played in many home DVD players and on computers with a CD-ROM drive and VCD player software.

1. From the **Tools** menu, choose **Burn CD** and choose **Video CD** from the submenu. The Burn Video CD dialog is displayed.

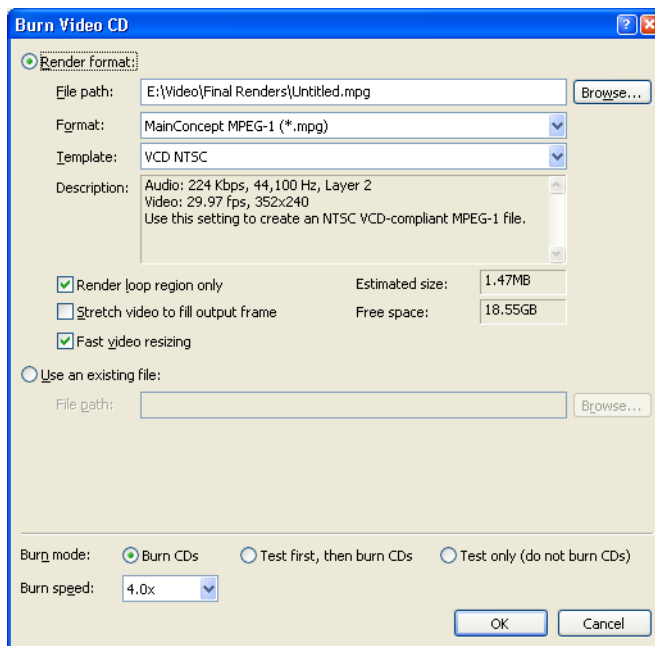

2. Choose the movie file you want to use:
 - If you want to render the current project, select the Render format radio button.
 - a. Edit the contents of the File path box to specify the name and location of your rendered file.
 - b. Choose a template from the Template drop-down list to specify the parameters that should be used for rendering your file, or click the Custom button to create a new template.
 - c. Select the Render loop region only check box if you want to use only a portion of your project. If the check box is cleared, the entire project will be rendered and saved to the Video CD.

d. Select the Stretch video to fill output frame check box if you want your video to be reformatted so it fills the output frame size listed in the Description box. When the check box is cleared, the current aspect ratio is maintained and black borders are added to fill the extra frame area (letterbox). This option is useful when the desired output format does not match the frame aspect ratio of your project.

Note: Clear the Fast video resizing check box if you see unacceptable artifacts in the rendered video. Turning off this option can correct the artifacts, but your rendering times will increase significantly.

- If you want to use an already-rendered MPEG file, select the Use an existing file radio button, and enter the path to the file in the File path box (or click the Browse button to locate the file).

3. Select recording options for your CD-recordable drive:

a. Choose a burn mode:

- Burn CDs begins recording audio to your CD immediately.
- Test first, then burn CDs performs a test to determine whether your files can be written to the CD recorder without encountering buffer underruns. No audio is recorded to the CD during the test, and recording begins after the test if it is successful.
- Test only (do not burn CDs) performs a test to determine whether your files can be written to the CD recorder without encountering buffer underruns. No audio is recorded to the CD.

b. From the Burn speed drop-down list, choose the speed at which you want to record. **Max** will record using the fastest speed possible with your drive; decrease the speed if you have difficulty recording.

4. Your movie is recorded to the CD. When recording is finished, you can select the Save movie file check box to keep the MPEG file that was rendered, or you can clear the check box to delete the file.

5. Click Finish.

Creating a multimedia CD

 *CD burning is only available in the full version of Vegas software.*

From the **Tools** menu, choose **Burn CD** and choose **Multimedia CD** from the submenu to render your project and burn it to a data CD. The rendered project can be played in any computer with the appropriate player.

1. From the **Tools** menu, choose **Burn CD**, and choose **Multimedia CD** from the submenu. The Burn Multimedia CD dialog appears.

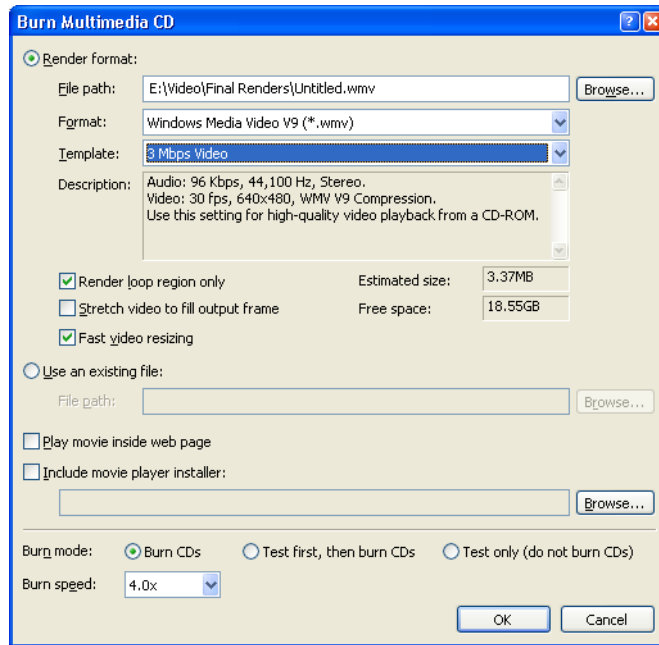

2. Select the options for burning the multimedia CD:

- Choose the appropriate format and template for rendering the project from the Format and Template drop-down lists.
- Select the Render loop region only check box to burn only a portion of your project.
- Select the Stretch video to fill output frame check box to have your video reformatted so that it fills the output frame size listed in the Description box. When the check box is cleared, the current aspect ratio is maintained and black borders are added to fill the extra frame area (letterboxing).
- Clear the Fast video resizing check box if you see unacceptable artifacts in the rendered video. Turning off this option can correct the artifacts, but it increases rendering time significantly.
- Select the Play movie inside web page check box to create an HTML page and embed the finished video in it.
- Select the Include movie player installer check box to include a media player installer on the CD. Click the Browse button to locate the installer file.
- From the Speed drop-down list, choose the speed at which you want to record. The Max option records using the fastest speed possible with your drive. Decrease the speed if you have difficulty recording.

3. Click OK.



Using Scripting

Using the scripting features, Vegas® software becomes an even more powerful and flexible tool. You can use scripting to streamline repetitive tasks, integrate with external applications, and implement customized features.

To use scripting, you'll need to install the Microsoft® .NET Framework. This component is available from the Microsoft Windows® Update site. (Choose **Windows Update** from the  menu.)

Note: To use scripts that were created for Vegas 4.0 software, you'll need to revise the script's namespace from *SonicFoundry.Vegas* to *Sony.Vegas*. For example, the line that includes "import *SonicFoundry.Vegas*;" should be changed to "import *Sony.Vegas*;" before running the script.

 Scripting is only available in the full version of Vegas software.

Running a script

1. From the **Tools** menu, choose **Scripting**, and then choose **Run Script** from the submenu. The Run Script dialog is displayed.

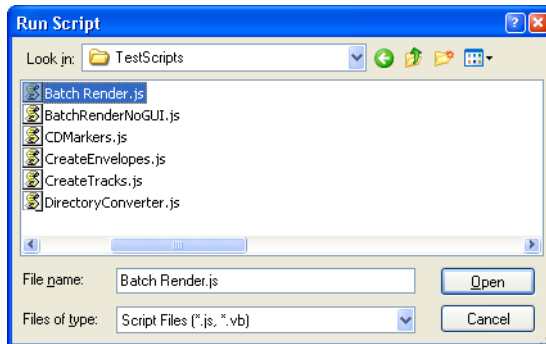

2. Browse to the script file (.vb or .js) you want to run.
3. Select the file and click the Open button. The script runs.

Adding scripts to the Scripting menu

When you start the program, Vegas software looks at the Script Menu folder in the Vegas program folder to determine which scripts appear in the Scripting submenu. This folder is c:\Program Files\Sony\Vegas 5.0\Script Menu by default.

1. Add or delete scripts in the Script Menu folder to change the contents of the submenu.

Note: To prevent duplication of script files, you can use shortcuts in the Script Menu folder.

2. From the **Tools** menu, choose **Scripting**, and then choose **Rescan Script Menu Folder** to update the menu.

Creating a script

The Microsoft .NET framework is used for scripting. You can write scripts in JScript or Visual Basic .NET.

For more information on JScript®, see <http://msdn.microsoft.com/library/en-us/jscript7/html/jsoriJScript.asp>.

For more information on Visual Basic® .NET, see <http://msdn.microsoft.com/library/en-us/vbcn7/html/vaconProgrammingWithVB.asp>.

Editing an existing script

All you need to edit a script is a simple text editor (and a working knowledge of JScript or Visual Basic .NET scripting). The scripts that are included are fully commented to help you find and edit the parameters you need.

1. Create a copy of the script (.vb or .js) file you want to edit, assigning a descriptive name to the copy.
2. Open the new copy of the script in your text editor.
3. Edit the script as needed. The comments in the script will help you find the parameters you need to edit.

Comments are indicated with double forward slashes: //.

For example, the AddEffectToAllMedia.js script includes the following lines:

```
// This is the full name of the effect plug-in you want to add.
var plugInName = "Sony Timecode";

// This is the name of the preset you want. Set this to null if you
// want the default preset.
var presetName = "SMPTE Drop (29.97 fps)";
```

The default script applies the Sony Timecode plug-in to all video media in your project using the SMPTE Drop (29.97 fps) preset. If you wanted to apply the Broadcast Colors plug-in's Extremely Conservative - 7.5 Setup preset to all audio media, you could edit the script as follows (changes appear in red):

```
// This is the full name of the effect plug-in you want to add.
var plugInName = "Sony Broadcast Colors";
```

```
// This is the name of the preset you want. Set this to null if you
// want the default preset.
var presetName = "Extremely Conservative - 7.5 Setup";
```

The `plugInName` variable should use the plug-in name that is displayed in the Plug-In Chooser. The `presetName` variable should use the preset name that is displayed in the Preset box in the FX window.

4. Save the script.

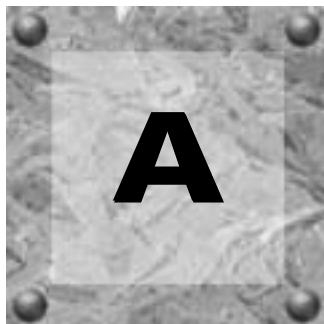

Troubleshooting

Troubleshooting resources

Visit the Sony Pictures Digital Web site to access product updates, look for answers in the knowledge base, contact customer support, or participate in an online forum:

<http://www.sony.com/mediasoftware>

Common questions

Why are some of my DirectX plug-ins not working correctly?

Vegas® software is a nondestructive time-based editor. As a result, there are certain types of DirectX® plug-ins that perform poorly in Vegas software. These types of plug-ins are roughly classified as any plug-ins that output a different amount of time than what goes in. This includes all plug-ins such as time compress/expand, gapper/snipper and pitch shift without preserving duration. However, these types of effects plug-ins may perform suitably as bus effects, but *only* if just one bus is used in the project. Plug-ins that require a lot of pre-buffering (such as Sony Pictures Digital Acoustic Mirror™ when using long impulse files) may also perform poorly.

Also, make certain that the plug-ins you use in Vegas software are DirectX plug-ins and not DXi plug-ins. DXi plug-ins are not supported in the application and do not perform properly.

Why do I hear gaps in my audio playback?

Check to see if any Vegas software updates have been posted on the Sony Pictures Digital Media Software and Services Web site:

<http://mediasoftware.sonypictures.com/download>

Click Updates to access the Updates page. Any updates to the application are posted at this location.

If software updates do not address the playback problem, check these other reasons that your audio playback can gap:

- Playing back too many tracks simultaneously can overload your hard drives.
- Not enough physical RAM can cause the Windows® operating system to use virtual memory, which is slower.
- Your CPU may not be able to process a complex mix of plug-ins.
- Problematic video card settings. *For more information, see [Trouble-free video: hardware solutions](#) on page 320.*

The following are some things you can check and do to make sure your system is optimized to prevent gapping.

RAM usage

You could be gapping because virtual memory is being used. Virtual memory is a method used by Microsoft Windows to write information to your hard drive to make room in physical RAM. This process uses a lot of your computer's resources. Try the following to optimize RAM usage:

- Exit all background applications not in use.
- Adjust the playback buffering slider on the Audio tab in the Preferences dialog. Adjust this slider as low as possible. However, be aware that setting it too low may cause gaps as well. *For more information, see [Adjusting the playback buffering slider](#) on page 298.*
- Mute/solo some of the events or tracks in the mix.
- Add more RAM to your computer.

Disk usage

You may experience gapping when data is not being read off the hard drive fast enough. Try the following to optimize disk usage:

- Fully defragment your audio hard drives regularly.
- Split audio usage between different physical hard drives, not just different partitions of the same drive.
- Run fewer events simultaneously. It is not how many tracks you have in the project, but how many different events are playing simultaneously that matters.
- Make sure that you trim out any silent sections of events to minimize the wasted disk access.
- Use hard drives with fast seek times and spindle speeds of 7200 RPM or greater. SCSI drives usually have better prolonged data transfer performance than IDE drives. Under Microsoft Windows XP and Windows 2000 operating systems, Vegas software can take advantage of SCSI asynchronous reads, which can be a big performance advantage.

CPU usage

If you have checked your RAM usage and disk usage and you are still experiencing gapping, you can try to adjust how Vegas software utilizes the central processing unit (CPU). Try the following to optimize CPU usage:

- Zoom out (**Ctrl** + **↓**) fully on the track view while playing so that the screen does not have to scroll to keep the cursor on it.
- Run fewer DirectX plug-ins.
- Make sure that the peak files are built for all of the audio data in the project before playing. Peaks are only built for those files on screen. If all peak files are not built, you can encounter gapping when the screen scrolls as it plays and the application must build peaks on the fly. Press **F5** before playback to rebuild peaks for all of the events, on or off of the screen.

Why do mono events increase 6 dB when panning a track hard?

In Vegas software, all audio events are treated as stereo. A mono audio event is interpreted as a stereo event with the same data in both channels. If you're using the add channels panning mode, this duplication doubles the amplitude and results in a 6 dB increase in volume when you pan a track hard left or right. Try using the constant power panning mode instead. Right-click the multipurpose slider and choose **Constant Power** from the shortcut menu. *For more information, see [Adjusting stereo panning](#) on page 110.*

Why do buffer underruns occur during a test or real write to a CD?

Buffer underruns occur when data transferred to the CD-R is too slow. This may be caused by a variety of factors relating to optimizing your system. Try writing the CD at a slower speed or prerendering the audio. *For more information, see [Burning a disc \(disc-at-once\)](#) on page 311.*

Why can't I work with footage captured using an MJPEG card?

Vegas software requires that you have the MJPEG codec (for the MJPEG card used to capture the video) installed locally on your workstation. Check to make sure that the appropriate MJPEG codec is installed on your PC.

Trouble-free video: software solutions

There are literally dozens of possible configurations of hardware for editing video on a PC. While it is impossible to go into detail for each and every system, the following explains some of the concepts behind the various settings in Vegas software. Editing and playing back full-frame, 30 fps video is one of the most demanding activities for any computer. The hardware you use is an important part of the equation, but there are a number of things you can do to optimize your PC for video. The following list is arranged from the most to the least important.

- Close all other applications. When capturing video or playing it back, it is critical that no other applications interrupt this process. Close any applications that are not vital. This includes screen savers, task schedulers, and even virus-detection software. You can ensure that you have closed all unnecessary applications by pressing **Ctrl** + **Alt** + **Delete**, selecting the individual applications, and clicking the End Task button to close them. Certain processes are required and should not (cannot) be terminated (for example, Explorer).
- Check your virtual memory. Windows operating system uses virtual memory when RAM is low. This is a method for Windows to use the hard disk to create more memory and is sometimes called a paging file. If Windows tries to write to the paging file during playback or capture, this can interrupt the video software and cause problems. Make sure that a different disk drive is being used for virtual memory other than the one from which you are capturing or playing your video. If you have enough space, use C:\ for virtual memory and use a physically distinct drive for capturing and playing back video.
- Make sure you have the latest drivers for your video card and capture card and the latest updates and patches to all relevant software. One caveat to this is that you shouldn't try to fix a program that is working correctly. Many times patches and updates fix relatively minor bugs that only affect a small number of users. If you are not experiencing any problems, it is probably best not to upgrade unless the manufacturer recommends it.
- Uncompressed video may be high quality, but it results in very large files with very high data rates. Selecting a more appropriate compression scheme (codec) will definitely improve the situation. If you are creating movies that need maximum quality, however, this may not be an option.

Trouble-free video: hardware solutions

Even with a fast computer, video is still a hardware challenge. On the other hand, it is definitely possible to properly configure a 400 MHz Pentium to work with large video files. There are three parts of your PC that are important and the speed of your CPU is not necessarily the most critical. The following list is arranged from the most to the least important.

Video subsystem

Many graphics cards (video boards, primary display cards) on a PC cannot handle full-screen, full-frame rate video. While this leads to jerky, hesitating playback, it may not actually be a serious problem. A common video configuration is to have a separate video capture card and a primary display card. In this case, the playback using the primary display on the computer may be jerky, but when you finally output the video to tape and view it on your television monitor there may not be any problems. If you are *not* creating movies to go back to the television or VCR and you are experiencing stuttering playback, you should consider using a smaller frame size (320X240) and frame rate (15 fps).

Hard disk

The second most common problem is slow hard disks. Until recently, fast, expensive SCSI AV hard disks were required to properly capture and play back video on a PC. Slow hard disk problems also manifest themselves with jerky video playback, although the stutters are less frequent and of longer duration than if the video subsystem is the problem. Slower hard disks (e.g., 5400 RPM IDE) can cause an occasional dropped frame. DV enthusiasts have fewer problems due to the low data rate (~3.6 MB/sec.) of that format. The following section outlines some recommendations arranged in order of importance.

- **Buy a dedicated video drive.** This is easily the most important piece of hardware advice. A dedicated, physically distinct hard drive is almost a requirement for any type of serious video work. This means that you have one primary C:\ drive (or wherever your operating system is installed) and a separate drive for video. You can use your dedicated drive for other purposes, especially storage, but it is a good idea not to run any applications from it and to keep Windows virtual memory off of it. It is very important that the drive only be used for video when playing and capturing, and that other programs (including Windows) are not trying to access it. Since video files are so large, a dedicated drive is not an unreasonable item even if digital video is just a hobby. You can never have too much hard disk space.
- **Buy a faster hard drive.** Older 5400 RPM hard drives may not be fast enough for capturing and playing back video for any length of time, while newer 7200 RPM drives are almost always adequate. Be careful: manufacturers are usually talking about burst transfer rates when they talk about the speed of a drive. A drive that can transfer data at 80MB/sec is worthless for video if it cannot sustain a much slower rate of 8MB/sec for thirty minutes (or more) without dropping a frame. Look to other computer video enthusiasts for additional advice. Again, the RPMs are a very good indicator, because 7200 RPM IDE drives are usually newer (c.1998) and older 7200 RPM drives are usually SCSI, which are already higher quality drives to begin with.
- **IDE vs. SCSI.** While this *was* a big issue just a few years ago, it has fortunately faded in importance. Hard drives can be hooked up to your computer in a number of ways, with the two largest divisions being IDE and SCSI. This interface simply determines how much data can be transferred to and from the drive in a second. The interface almost always far outstrips the performance of even the best hard disks and even the slower interfaces exceed the transfer requirements of video data. SCSI hard disks are usually more expensive and require a special controller, and while SCSI-2 promises 80MB/sec transfer rates, this is overkill for most people. Newer IDE hard disks with designations of EIDE, DMA, Ultra-DMA, ATA-33, and ATA-66 (and newer drives that came out after this writing) can all handle most sustained video requirements.

CPU and RAM (memory)

While the CPU and the RAM are probably the most important overall aspects of a PC's speed and performance, these factors are only third on the list for video. For the most part, these critical components do not affect the capture or playback of video. This does not mean that a faster CPU or more RAM will not help, because bigger and faster is always better: CPU and RAM definitely impact rendering speeds. Creating a final AVI file, especially in a movie project that uses a lot of effects and transitions, can take a long time. A thirty-minute movie could easily take six or more hours to render, depending on the format and effects used. CPU speed is also important for more advanced compression codecs, such as MPEG and newer streaming formats.

Audio proxy files (.sfap0)

Working with certain types of media files with particular audio compression schemes can be inefficient and slow. To compensate for this, Vegas software creates audio proxy files for formats that are known to dramatically impact performance. There are two cases where this occurs.

Multimedia video files often contain both video and audio information. In certain formats, these two streams can be packed together in such a way as to make editing slow and inefficient. Vegas software therefore takes the audio stream from these files (e.g., type-1 DV, QuickTime™) and saves it to a separate and more manageable audio proxy file.

QuickTime audio-only files can also be compressed in a way that makes editing slower. Vegas software also uses audio proxy files in this situation as well. While audio proxy files may be large (because they are uncompressed), the performance increase is significant.

The file is saved as a proprietary .sfap0 file, with the same name as the original media file and has the same characteristics as the original audio stream. So *movie.avi* yields a *movie.avi.sfap0* audio proxy. Additional audio streams in the same file are saved as *movie.avi.sfap1*, *movie.avi.sfap2*, etc. This is a one-time process that greatly speeds up editing. The conversion happens automatically and does not result in a loss of quality or synchronization. The original source file remains unchanged (the entire process is nondestructive). Audio proxy files can be safely deleted at any time since the application recreates these files as needed.

Note: Vegas software saves audio proxy files to the same folder as the source media. If the source media folder is read-only (e.g., CD-ROM), the files are saved to a temporary directory.

Interlacing and field order

Field order in interlaced video is an important parameter that can severely impact the quality of video on a television monitor. While the concept is easy enough to understand, the lack of standards in both technology and terminology clouds the issue.

The path of the electron gun across the screen is fundamentally different between television monitors and computer monitors. Computer monitors scan every line in order, from left to right and top to bottom. This is known as progressive scanning. On a standard television monitor, the electron gun scans every other line from top to bottom, twice for every picture or frame. For example, the first scan from top to bottom might scan all of the odd numbered lines first, then jump back to the top of the screen and, in the second scan, draw all of the remaining even numbered lines, completing the frame. The two fields are said to be interlaced together to form a single frame.

The illustration that follows shows how two frames in a video are actually composed of two fields each, for a total of four fields. These fields can be referred to as field one (F1) and field two (F2). Obviously, it is critical that these two fields are paired together to create a whole frame. What may not be so obvious is that the actual order of these two fields is not particularly important. In other words, F1 could be scanned first and then F2, or F2 could be scanned first and then F1. Both situations would create a perfectly valid, error-free frame of video. While that may sound like good news, in reality this is the source of all of the problems associated with field order. Since both methods are technically correct, both methods have been used. It is important to use the correct order when rendering video files for your particular hardware (capture card).

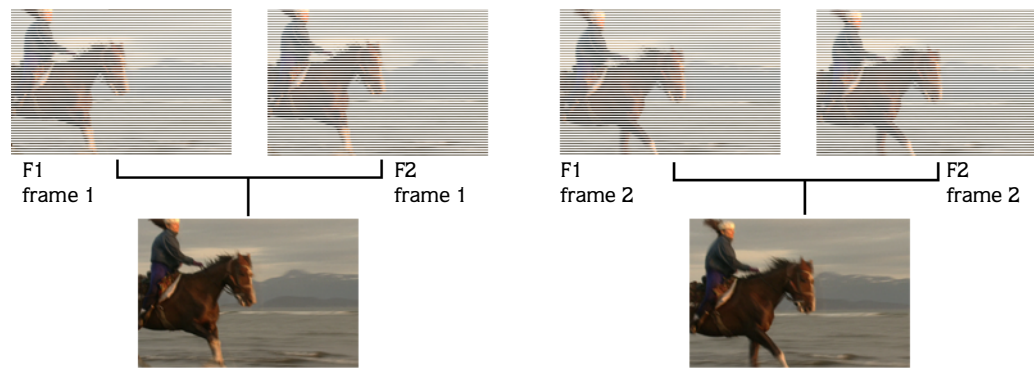

The next illustration shows the effects of incorrectly interlacing a frame of video. In this case, F2 from frame one is combined with F1 from frame two. Remember that there is nothing inherently right or wrong with a field order of F2/F1; it just happens to be wrong in this case. At a minimum, this can create slightly blurry or hazy video. In most situations, the video is jumpy or jittery and is unwatchable. Interlacing problems can be especially noticeable when two adjacent frames are significantly different; for example, at a cut or in video with fast moving action. It can also manifest itself in certain computer-generated special effects; for example, in slow-motion sequences.

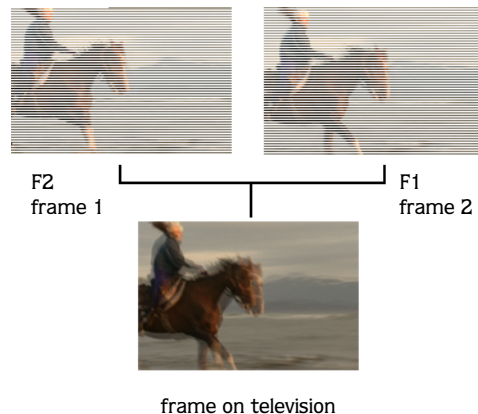

The basic problem is that there is no standard correct field order. Some capture cards use F1/F2 and some use F2/F1. If this were the extent of our troubles, we could check out our hardware manual, look up the correct field order and that would be that. Unfortunately (if this information is even available) the terminology used can be equally baffling. F1 may be called the odd, upper, or A field, or (more rarely) it may be called the even, lower, or B field. Add into the mix the fact that the first scan line might be numbered 0 or 1 (which changes whether the field is considered odd or even), and that cropping may change which line is ultimately scanned first, and you can see that this is not a very clear-cut problem. The remainder of this section deals with how to sort this out in Vegas software. Fortunately, you only have to determine the correct settings once for any particular hardware setup.

Identifying problems

Vegas software refers to the two fields as upper field first and lower field first. These are probably the most common terms used to distinguish the two fields, and you may find a page in your hardware's manual that says something like "Use a field order of lower first." In many cases (but not all or even most), Upper=Odd=A and Lower=Even=B.

In the application, you can select the field order of a project by choosing **Properties** from the **File** menu and clicking the **Video** tab. The pre-configured templates should work for almost everyone (e.g., if you are editing and outputting DV video in the US, select the NTSC DV template). If you have problems, you can manually select a different field order on the **Video** tab. You can also override the project settings and set the field order when you render a video file. From the **File** menu, choose **Render As**. Then, click the **Custom** button and choose an option from the **Field order** drop-down list on the **Video** tab. You can also set field order at the level of the media file or event. Right-click a media file in the **Media Pool** or an event on the **timeline** and choose **Properties**. The **Field order** drop-down list appears on the **Media** tab.

Interlacing problems only manifest themselves on television monitors. Video that is going to be played back on a computer does not need to be interlaced, and you can select **None** (progressive scan) for the field order. Rendered video must be displayed on a television monitor to identify any problems. The only way to see interlacing problems is to record (print) a rendered video file out to tape and play back the tape on a television. Problems are most apparent in video that has a lot of motion or that has been modified in some way; for example, a slow-motion effect. (Some codecs force the correct field order during a render, making it difficult or impossible to create video with the wrong field order.)

Solving interlacing problems in Vegas software

If your hardware's documentation does not contain any information about the proper field order, you must determine this information for yourself. It is not a difficult process, and involves rendering one video file with an upper first field order and another with a lower first field order. Source material that dramatically and clearly demonstrates the improperly interlaced video is important: use a media file with a lot of motion in it and then slow the event down with a velocity envelope or by time-stretching the event.

Timecode

Timecode is a method of labelling frames with a unique and searchable identifier. It is primarily important for synchronizing video (in frames per second) with time in the real world and, in the case of Vegas software, with other media in a project.

Changing the timecode used to measure a video file does not alter the contents of the file. For example, no frames are ever dropped or removed when using SMPTE 29.97 drop frame timecode. Instead, specific frame numbers are periodically dropped to compensate for differences between timecode and time in the real world. Confusion between using drop versus non-drop timecode can cause synchronization problems between video and audio. For very short periods of time, the error would be unnoticeable. After about a half an hour, you might notice that mouths and words do not quite match in shots of people speaking. Longer stretches of time show larger discrepancies in synchronization.

Changing the timecode displayed on an event is not equivalent to converting a video to another format. You cannot convert NTSC video at 29.97 fps to PAL video at 25 fps by simply changing the timecode. To convert NTSC video to PAL video in Vegas software, you need to re-render the video in the new format. In this situation, the conversion process necessarily results in some frames of video actually being removed from the original sequence.

SMPTE timecode types

The following are descriptions of each of the Society of Motion Picture and Television Engineers (SMPTE) timecode types.

SMPTE 25 EBU (25 fps, Video)

SMPTE 25 EBU timecode runs at 25 fps, and matches the frame rate used by European Broadcasting Union (EBU) television systems.

Use SMPTE 25 EBU format for PAL DV/D1 projects.

SMPTE Drop Frame (29.97 fps, Video)

SMPTE Drop Frame timecode runs at 29.97 fps, and matches the frame rate used by NTSC television systems (North America, Japan).

Use SMPTE Drop Frame format for NTSC DV/D1 projects.

Both SMPTE Drop and SMPTE Non-Drop run at 29.97 fps. In both formats, the actual frames are not discarded, but they are numbered differently. SMPTE Drop removes certain frame numbers from the counting system to keep the SMPTE clock from drifting from real time. The time is adjusted forward by two frames on every minute boundary except 0, 10, 20, 30, 40, and 50. For example, when SMPTE Drop time increments from 00:00:59.29, the next value is 00:01:00.02.

SMPTE Non-Drop Frame (29.97 fps, Video)

SMPTE Non-Drop Frame timecode runs at a rate of 29.97 fps. This leads to a discrepancy between real time and the SMPTE time, because there is no compensation in the counting system as there is in SMPTE Drop Frame.

Use SMPTE Non-Drop format for NTSC D1 projects that are recorded on master tapes striped with Non-Drop timecode.

SMPTE 30 (30 fps, Audio)

SMPTE 30 is an audio-only format and runs at exactly 30 fps. SMPTE 30 is commonly used when synchronizing audio applications such as multitrack recorders or MIDI sequencers. This format should not be used when working with video.

SMPTE Film Sync (24 fps)

The SMPTE Film Sync time format runs at 24 fps (frames per second). This frame rate matches the standard crystal-sync 16/33 mm film rate of 24 fps.

Timecode in Vegas software

Video timecode crops up fairly frequently in Vegas software. Being a multimedia production tool, time in the application can be measured in real-world time (hours, minutes, seconds), in video timecode (involving frames of video), or in musical time (measures and beats).

Ruler format and timecode

The ruler in Vegas software can be set to measure time in any way that is convenient. This setting does not change how the final file is rendered, but controls the grid lines and how snapping behaves. Right-click the ruler and choose a time format from the shortcut list. *For more information, see [Changing the ruler format on page 287](#).*

Preferences dialog timecode settings

From the **Options** menu, choose **Preferences** and click the **Video** tab to adjust the Show source frame numbers on event thumbnails as drop-down list. These settings take precedence over those found in the source media Properties dialog (see the next topic) and are displayed on events inserted into the timeline. None means that no numbers are displayed on events, Frame Numbers marks frames in the media file starting with 0, Time displays the time in seconds, and Timecode allows the source media's timecode to be detected or selected.

Source media timecode format

Right-click an event, choose **Properties**, and click the **Media** tab to view these properties. By default, Use timecode in file is selected.

Note: You can override these settings by choosing different settings on the **Video** tab of the **Preferences** dialog. Select **Timecode** from the **Source** frame numbering list to allow event-level specification.

Render media file format

The timecode of a final rendered media file is determined by the specified format. The frame rate of the project ultimately determines the timecode and is often constrained by the type of media file being rendered or the codec being used for compression. For example, NTSC DV is typically limited to a frame rate of 29.97 fps and uses SMPTE drop frame timecode.

Time formats in Vegas software

A variety of time formats are provided in the application. For more information, see [Changing the ruler format](#) on page 287.

Troubleshooting DV hardware issues

Vegas software is designed to integrate seamlessly with OHCI compliant IEEE-1394 DV video capture hardware and DV camcorders. While most people never have any problems, the vast number of hardware configuration possibilities makes this a potentially complex issue. There are a number of resources at the Sony Pictures Digital Media Software and Services Web site that may be able to assist you.

More detailed information is available at:

<http://mediasoftware.sonypictures.com/Support/Productinfo/OHCI.asp>

You can also visit the Vegas Updates Web page to access a troubleshooting document for OHCI-compliant devices. From the Sony Pictures Digital Media Software home page, go to the Download page and click Updates. Click the Vegas Update link to access the update page.

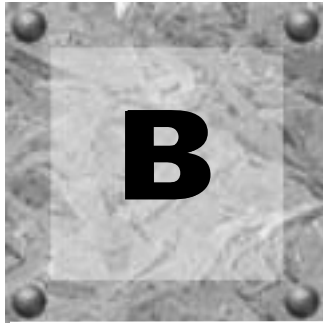

Glossary

A-Law

A companded compression algorithm for voice signals defined by the Geneva Recommendations (G.711). The G.711 recommendation defines A-Law as a method of encoding 16-bit PCM signals into a nonlinear 8-bit format. The algorithm is commonly used in United States telecommunications. A-Law is very similar to μ -Law, however, each uses a slightly different coder and decoder.

Adaptive Delta Pulse Code Modulation (ADPCM)

A method of compressing audio data. Although the theory for compression using ADPCM is standard, there are many different algorithms employed. For example, the ADPCM algorithm from Microsoft® is not compatible with the International Multimedia Association's (IMA) approved ADPCM.

Aliasing

A type of distortion that occurs when digitally recording high frequencies with a low sample rate. For example, in a motion picture, when a car's wheels appear to slowly spin backward while the car is quickly moving forward, you are seeing the effects of aliasing. Similarly, when you try to record a frequency greater than one-half of the sampling rate (the Nyquist Frequency), instead of hearing a high pitch, you may hear alias frequencies in the low end of the spectrum.

To prevent aliasing, an anti-aliasing filter is used to remove high-frequencies before recording. Once the sound has been recorded, aliasing distortion is impossible to remove without also removing other frequencies from the sound. This same anti-aliasing filter must be applied when resampling to a lower sample rate.

Amplitude Modulation (AM)

A process whereby the amplitude (loudness) of a sound is varied over time. When varied slowly, a tremolo effect occurs. If the frequency of modulation is high, many side frequencies are created which can strongly alter the timbre of a sound.

Analog

When discussing audio, this term refers to a method of reproducing a sound wave with voltage fluctuations that are analogous to the pressure fluctuations of the sound wave. This is different from digital recording in that these fluctuations are infinitely varying rather than discrete changes at sample time (see Quantization).

ASIO

ASIO (Audio Stream In/Out)™ is a low-latency driver model developed by Steinberg Media Technologies AG.



ASIO audio drivers are only supported in the full version of Vegas® software.

Attack

The attack of a sound is the initial portion of the sound. Percussive sounds (drums, piano, guitar plucks) are said to have a fast attack. This means that the sound reaches its maximum amplitude in a very short time. Sounds that slowly swell up in volume (soft strings and wind sounds) are said to have a slow attack.

Attenuation

A decrease in the level of an audio signal.

Audio Compression Manager (ACM)

The Audio Compression Manager from Microsoft® is a standard interface for audio compression and signal processing for Windows. The ACM can be used by Microsoft® Windows® programs to compress and decompress WAV files.

AVI

A file format of digital video. Vegas software allows you to open, edit and create new AVI files.

Bandwidth

Refers to the EQ plug-in that is built in. Each frequency band has a width associated with it that determines the range of frequencies that are affected by the EQ. An EQ band with a wide bandwidth affects a wider range of frequencies than one with a narrow bandwidth.

Bandwidth can also refer to the amount of data that can be transferred via a connection, such as a network or modem. For example, streaming media must be compressed due to the limited bandwidth of most Internet connections.

Beats Per Measure

In music theory, the time signature of a piece of music contains two pieces of information: the number of beats in each measure of music, and which note value gets one beat. This notion is used to determine the number of ticks to put on the ruler above the track view, and to determine the spacing when the ruler displays in measures and beats format.

Beats Per Minute (BPM)

In music theory, the tempo of a piece of music can be written as a number of beats in one minute. If the tempo is 60 BPM, a single beat occurs once every second. Lower BPM's equal slower tempo, and vice versa.

Bit

A bit is the most elementary unit in digital systems. Its value can only be 1 or 0, corresponding to a voltage in an electronic circuit. Bits are used to represent values in the binary numbering system. As an example, the 8-bit binary number 10011010 represents the unsigned value of 154 in the decimal system. In digital sampling (specifically the PCM format), a binary number is used to store individual sound levels, called samples.

Bit Depth

The number of bits used to represent a single sample. Vegas software uses either 8, 16, or 24-bit samples. Higher values increase the quality of the playback and any recordings that you make. While 8-bit samples take up less memory (and hard disk space), they are inherently noisier than 16 or 24-bit samples.

Bus

A virtual pathway where signals from tracks and effects are mixed. A bus's output can be a physical audio device in the computer from which the signal is heard.

Byte

Refers to a set of 8 bits. An 8-bit sample requires one byte of memory to store, while a 16-bit sample takes two bytes of memory to store.

Clipboard

The Clipboard is where data that you have cut or copied in Vegas software is stored. You can then paste the data back into Vegas software at a different location, or paste it into other applications. Some data, such as audio, cannot be pasted into applications such as Microsoft Word or Notepad, but the text data from the Edit Details window can be pasted. This allows you to then print or format the data. The Video Preview window also lets you capture still frames to the Clipboard for use in any image editing program. *For more information, see [Understanding the Video Preview window](#) on page 253.*

Clipping

Clipping is what occurs when the amplitude of a sound is above the maximum allowed recording level. In digital systems, clipping is seen as a clamping of the data to a maximum value, such as 32,767 in 16-bit data. Clipping causes sound to distort.

Codec

An acronym for COmpressor/DECompressor. A codec is a computer algorithm that is used to compress video and audio data, shrinking file sizes and data rates.

Compositing

Compositing is the term used to describe the way separate video sources are mixed together. Overlay titles are composited onto a background video sequence.

Crossfade

Mixing two pieces of overlapping audio or video by fading one out as the other fades in.

Cutoff frequency

The cutoff frequency of a filter is the frequency at which the filter changes its response. For example, in a low-pass filter, frequencies greater than the cutoff frequency are attenuated while frequencies less than the cutoff frequency are not affected.

DC Offset

DC Offset occurs when hardware, such as a sound card, adds DC current to a recorded audio signal. This current causes the audio signal to alternate around a point above or below the normal -infinity dB (center) line in the sound file. To see if you have a DC offset present, you can zoom all the way into a sound file and see if it appears to be floating over the center line.

Decibel (dB)

A unit used to represent a ratio between two numbers using a logarithmic scale. For example, when comparing the numbers 14 and 7, you could say 14 is two times greater than the number 7; or you could say 14 is 6 dB greater than the number 7. Where did we pull that 6 dB from? Engineers use the equation $\text{dB} = 20 \times \log(V1/V2)$ when comparing two instantaneous values. Decibels are commonly used when dealing with sound because the ear perceives loudness in a logarithmic scale.

In Vegas software, most measurements are given in decibels. For example, if you want to double the amplitude of a sound, you apply a 6 dB gain. A sample value of 32,767 (maximum positive sample value for 16-bit sound) can be referred to as having a value of 0 dB. Likewise, a sample value of 16,384 can be referred to having a value of -6 dB.

Device Driver

A program that enables Microsoft Windows to connect different hardware and software. For example, a sound card device driver is used by Microsoft Windows software to control sound card recording and playback.

Digital Signal Processing (DSP)

A general term describing anything that alters digital data. Signal processors have existed for a very long time (tone controls, distortion boxes, wah-wah pedals) in the analog (electrical) domain. Digital Signal Processors alter the data after it has been digitized by using a combination of programming and mathematical techniques. DSP techniques are used to perform many effects such as equalization and reverb simulation.

Since most DSP is performed with simple arithmetic operations (additions and multiplications), both your computer's processor and specialized DSP chips can be used to perform any DSP operation. The difference is that DSP chips are optimized specifically for mathematical functions while your computer's microprocessor is not. This results in a difference in processing speed.

DirectX Application Programming Interface

A set of interfaces designed by Microsoft for multimedia development. A DirectX® plug-in, such as the Sony Pictures Digital Noise Reduction™ DirectX plug-in, uses the DirectX Media Streaming Services (DMSS) API. Because DMSS is a standard API, a DirectX plug-in can be used in any application that supports DMSS.

Dithering

The practice of adding noise to a signal to mask quantization noise (see also Noise Shaping).

Drag and Drop

A quick way to perform certain operations using the mouse. To drag and drop, you click and hold a highlighted selection, drag it (hold the left-mouse button down and move the mouse) and drop it (let go of the mouse button) at another position on the screen.

Dynamic Range

The difference between the maximum and minimum signal levels. It can refer to a musical performance (high volume vs. low volume signals) or to electrical equipment (peak level before distortion vs. noise floor). For example, orchestral music has a wide dynamic range, while thrash metal has a very small (always loud) range.

Emphasis

A rudimentary noise reduction process that involves a boost in the high frequencies during the recording of the CD and a complimentary cut in the same frequencies during the playback of the CD. The result reduces high frequency noise without disrupting the natural frequency response of the source material. If the emphasis flag is set for a track, any CD player that has a de-emphasis circuit will impart the high frequency cut on the track. Be aware that Vegas software cannot impart the pre-emphasis boost on a track; it can only set the emphasis flag.

Endian (Little and Big)

Little and Big Endian describe the ordering of multi-byte data that is used by a computer's microprocessor. Little Endian specifies that data is stored in a low to high-byte format; this ordering is used by the Intel® microprocessors. Big Endian specifies that data is stored in a high to low-byte format; this ordering is used by the Motorola® microprocessors.

Envelopes (Audio and Video)

Envelopes, as used by Vegas software, are a way of automating the change of a certain parameter over time. In the case of volume, you can create a fade out (which requires a change over time) by adding an envelope and creating an extra point to the line that indicates where the fade starts. Next, you pull the end point of the envelope down to -inf. *For more information, see [Working with track envelopes](#) on page 126.*

Equalization (EQ)

The process by which certain frequency bands are raised or lowered in level. EQ has various uses. The most common use in Vegas software is to simply adjust the subjective timbral qualities of a sound.

Event

Media files that have been dragged onto the timeline in Vegas software are referred to as events. An event is actually a window into a media file and is a reference, or pointer, to the file. It can display all or part of a media file and can be edited without altering the source media (nondestructive).

Field Order

Video that is displayed on a television is interlaced. This means that every frame of video is actually composed of two fields, each of which is made up of half of the lines that make the final frame. These two fields are woven together in alternate lines, but which of the two fields is displayed first (the field order) can be important. You can set the field order for video in the Project Properties dialog or, when rendering a project, in the Custom Template dialog. *For more information, see [Interlacing and field order](#) on page 322.*

File Format

A file format specifies the way in which data is stored on your floppy disks or hard drive. In Windows for example, the most common audio file format is the Microsoft WAV format. However, Vegas software can read and write to many other file formats so you can maintain compatibility with other software and hardware configurations.

Frame Rate (Audio)

Audio uses frame rates only for the purposes of syncing to video or other audio.

Frame Rate (Video)

The speed at which individual images in the video are displayed on the screen. A faster frame rate results in smoother motion in the video. However, more times than not, frame rate is associated with SMPTE standard frame rates for video: 29.97 for NTSC (used in US, North and Central America, parts of South America, and Japan), 25 for PAL (used in many parts of the world, including Europe and much of Asia), or 24 for film.

Frequency Spectrum

The frequency spectrum of a signal refers to its range of frequencies. In audio, the frequency range is basically 20 Hz to 20,000 Hz. The frequency spectrum sometimes refers to the distribution of these frequencies. For example, bass-heavy sounds have a large frequency content in the low end (20 Hz - 200 Hz) of the spectrum.

Hertz (Hz)

The unit of measurement for frequency or cycles per second (CPS).

Insertion Point

The insertion point (also referred to as the cursor position) is analogous to the cursor in a word processor. It is where pasted data is placed or other data is inserted, depending on the operation. The insertion point appears as a vertical flashing black line and can be moved by clicking the left mouse button anywhere in the timeline.

Inverse telecine

Telecine is the process of converting 24 fps (cinema) source to 30 fps video (television) by adding pulldown fields. Inverse telecine, then, is the process of converting 30 fps (television) video to 24 fps (cinema) by removing pulldown.

Markers

Saved locations in the sound file. Markers can be displayed in the Trimmer window for sound files that contain them, but more often, markers and regions are used at the project level to mark locations or sections in the project.

Media Control Interface (MCI)

A standard way for Microsoft Windows programs to communicate with multimedia devices like sound cards and CD players. If a device has a MCI device driver, it can easily be controlled by most multimedia Microsoft Windows software.

Media File

A media file, or multimedia file, is any image, audio or video file on a computer. In Vegas software, you can browse for these files in the Explorer window. You can drag media files to the timeline or insert them into the Media Pool. Media files that have been dragged to the timeline are referred to as events.

MIDI Clock

A MIDI device specific timing reference. It is not absolute time like MIDI timecode (MTC); instead, it is a tempo-dependent number of ticks per quarter note. MIDI clock is convenient for synchronizing devices that need to do tempo changes mid-song.

MIDI Port

A MIDI Port is the physical MIDI connection on a piece of MIDI gear. This port can be a MIDI in, out or through. Your computer must have a MIDI port to output MIDI timecode to an external device or to receive MIDI timecode from an external device.

MIDI Timecode (MTC)

MTC is an addendum to the MIDI 1.0 Specification and provides a way to specify absolute time for synchronizing MIDI-capable applications. Basically, it is a MIDI representation of SMPTE timecode.

Mix

The process of combining multiple audio events and effects into a final output. The analogous process of combining video events together is called compositing.

Musical Instrument Digital Interface (MIDI)

A standard language of control messages that provides for communication between any MIDI compliant devices. Anything from synthesizers to lights to stage equipment can be controlled via MIDI. Vegas software utilizes MIDI for synchronization purposes.

Noise-shaping

Noise-shaping is a technique that can minimize the audibility of quantization noise by shifting its frequency spectrum. For example, in 44,100 Hz audio, quantization noise is shifted towards the Nyquist Frequency of 22,050 Hz. See also Dithering.

Nondestructive Editing

A type of editing used by Vegas software that involves a pointer-based system of keeping track of edits. When you delete a section of audio in a nondestructive system, the audio on disk is not actually deleted. Instead, a set of pointers is established to tell the program to play the active sections during playback.

Nonlinear Editing (NLE)

A method of editing video non-sequentially or in random order. Editing video in Vegas software is nonlinear as opposed to editing video tape, which is linear.

Normalize

Refers to raising the volume so that the highest level sample in the file reaches a user-defined level. Use this function to make sure you are fully utilizing the dynamic range available to you.

Nyquist Frequency

The Nyquist Frequency (or Nyquist Rate) is one-half of the sample rate and represents the highest frequency that can be recorded using the sample rate without aliasing. For example, the Nyquist Frequency of 44,100 Hz is 22,050 Hz. Any frequencies higher than 22,050 Hz produce aliasing distortion in the sample if an anti-aliasing filter is not used while recording.

OPT Plug-In

A plug-in that uses Open Plug-in Technology (OPT) standard from Yamaha™. OPT plug-ins provide tools for working with MIDI such as edit views, effect processors and filters, arpeggiators, and real-time panel automation.

Pan

To place a mono or stereo sound source perceptually between two or more speakers.

Peak File (.sfk)

Vegas software displays the waveform of audio files graphically on a computer monitor. This visual information must be generated by Vegas software when the audio file is opened and can take a few seconds. Vegas software then saves this information as a peak file (.sfk). This file stores the information for displaying waveform information so that opening a file is almost instantaneous. The peak file is stored in the directory in which the file resides and has an .sfk extension. If the peak file is not in the same directory as the file, or is deleted, Vegas software regenerates it the next time you open the file.

Pixel Aspect Ratio

Computers display pixels as squares: 1.0. Televisions display individual pixels as rectangles: 0.9091 (NTSC DV, D1), 1.0926 (PAL DV, D1), or other rectangular variations. Using the wrong pixel aspect ratio can result in distortions or stretching of the video. You can set the pixel aspect ratio in the Project Properties dialog or, when rendering, in the Custom Template dialog. You should choose the aspect ratio based on the final movie's destination. Consult your hardware manual if you are in doubt about the appropriate ratio. The pixel aspect ratio is unrelated to the frame's aspect ratio.

Plug-In

An effect that can be added to the product to enhance the feature set. Vegas software supports DirectX compatible plug-ins. The built-in EQ, Compression and Dithering effects are also considered plug-ins because they work in other DirectX-compatible applications.

Plug-In Chain

Plug-ins can be strung together into a chain so that the output of one effect feeds into the input of another. This allows for complex effects that couldn't otherwise be created.

Pre-roll/Post-roll

Pre-roll is the amount of time elapsed before an event occurs. Post-roll is the amount of time after the event. The time selection defines the pre- and post-roll when recording into a selected event.

Preset

A snapshot of the current settings in a plug-in. Presets are created and named so that you can easily get back to a sound or look that you have previously created.

A preset calls up a bulk setting of a function in Vegas software. If you like the way you tweaked that EQ, but do not want to have to spend the time getting it back for later use, save it as a preset. Presets appear in the top of plug-in windows in Vegas software.

Pulldown

In telecine conversion, fields are added to convert 24 fps film to 30 fps video.

In 2-3 pulldown, for example, the first frame is scanned into two fields, the second frame is scanned into three fields, and so on for the duration of the film. 2-3 pulldown is the standard for NTSC broadcasts of 24p material. Use 2-3 pulldown when printing to tape, but not when you intend to use the rendered video in Vegas software. Removing 2-3 pulldown is inefficient because the pulldown fields that are created for frame 3 span two frames:



24 fps film (top) and resulting NTSC video with 2-3 pulldown fields (bottom)

Use 2-3-3-2 pulldown when you plan to use your rendered video in Vegas software as source media. When removing 2-3-3-2 pulldown, Vegas software simply discards frame three and merges the pulldown fields in the remaining frames:

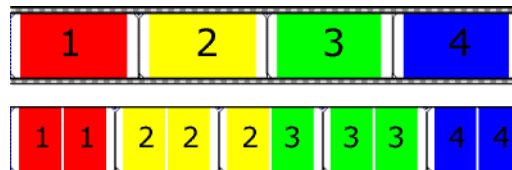

24 fps film (top) and resulting NTSC video with 2-3-3-2 pulldown fields (bottom)

Pulse Code Modulation (PCM)

PCM is the most common direct binary representation of a level of an uncompressed audio signal. This method of coding yields the highest fidelity possible when using digital storage.

Punch-In

Punching-in during recording means automatically starting and stopping recording at user-specified times. In Vegas software, shorter events can be punched into longer ones.

Quadraphonic

A mixing implementation that allows for four discrete audio channels. These are usually routed to two front speakers and two back speakers to create immersive audio mixes.

Quantization (Audio)

The process by which measurements are rounded to discrete values. Specifically with respect to audio, quantization is a function of the analog-to-digital conversion process. The continuous variation of the voltages of an analog audio signal are quantized to discrete amplitude values represented by digital, binary numbers. The number of bits available to describe these values determines the resolution or accuracy of quantization. For example, if you have 8-bit analog-to-digital converters, the varying analog voltage must be quantized to 1 of 256 discrete values; a 16-bit converter has 65,536 values. Quantization is to level as sampling rate is to time.

Quantization Noise

A result of describing an analog signal in discrete digital terms (see [Quantization](#)). This noise is most easily heard in low resolution digital sounds that have low bit depths and is similar to a hiss while the audio is playing. It becomes more apparent when the signal is at low levels, such as when doing a fade out. See also [Dithering](#).

Quantizing (MIDI)

The correction of rhythms to align with selected note lengths or beats in a MIDI sequence.

Quantizing (Video)

Limiting all editing to frame boundaries. *For more information, see [Quantizing to frames](#) on page 89.*

Red Book specification

The Red Book defines the specifications of every audio compact disc in every music store throughout the world. Red Book specifications define not only the information within the disc (digital audio recorded at 44.1 kHz), but also the disc size itself and the way in which the audio is arranged.

Region

A subsection of a sound file denoted by a start and end point. You can define any number of regions in a sound file.

Rendering

The process by which Vegas software saves the project to a specific file format like AVI or WMA.

Resample

The act of recalculating samples in a sound file at a different rate than the file was originally recorded. If an audio file is resampled at a lower rate, Vegas software decreases sample points. As a result, the file size and the frequency range are reduced. When resampling to a higher sample rate, Vegas software interpolates extra sample points in the sound file. This increases the size of the sound file but does not increase the quality. When down-sampling, one must be aware of aliasing (see [Aliasing](#)). Vegas software automatically resamples all audio to the project's sample rate.

Ripple; Ripple Editing

A type of editing where events are moved out of the way to make room for newly inserted events as opposed to simply being overwritten. When a one minute event is ripple inserted into a project, the duration of a project lengthens by one minute. If ripple editing is turned off, the same operation would not affect the overall duration of the project.

Roll

Originally, a conventional studio typically had two source decks that were used to play back video to a final destination or output deck. These two source decks were commonly referred to as the A and B rolls. In Vegas software, a video track can be configured to display an A and a B roll, which appear as sub-tracks. The concept is extended further in Vegas software to include a transition roll between the A and B rolls. *For more information, see [Understanding track layers](#) on page 234.*

Ruler

The ruler is the area above the tracks that shows the horizontal axis units.

Sample

The word sample is used in many different (and often confusing) ways when talking about digital sound. Here are some of the different meanings:

- A discrete point in time which a sound signal is divided into when digitizing. For example, an audio CD-ROM contains 44,100 samples per second. Each sample is really only a number that contains the amplitude value of a waveform measured over time.
- A sound that has been recorded in a digital format; used by musicians who make short recordings of musical instruments to be used for composition and performance of music or sound effects. These recordings are called samples. In this manual, we try to use sound file instead of sample whenever referring to a digital recording.
- The act of recording sound digitally (i.e., to sample an instrument) means to digitize and store it.

Sample Rate

The sample rate (also referred to as the sampling rate or sampling frequency) is the number of samples per second used to store a sound. High sample rates, such as 44,100 Hz provide higher fidelity than lower sample rates, such as 11,025 Hz. However, more storage space is required when using higher sample rates. Sampling rate is to time as quantization is to level.

Sample Size

See Bit Depth.

Sample Value

The sample value (also referred to as sample amplitude) is the number stored by a single sample. In 16-bit audio, these values range from -32768 to 32767. In 8-bit audio, they range from -128 to 127. The maximum allowed sample value is often referred to as 100% or 0 dB.

.sfp0

Sony Pictures Digital audio proxy file. *For more information, see [Audio proxy files \(.sfp0\)](#) on page 322.*

.sfk

See Peak File.

Shortcut Menu

A context-sensitive menu that appears when you right-click certain areas of the screen. The functions available in the shortcut menu depend on the object being clicked on as well as the state of the program. As with any menu, you can select an item from the shortcut menu to perform an operation. Shortcut menus are used frequently in Vegas software for quick access to many commands. An example of a shortcut menu can be found by right-clicking any event along the timeline.

Signal-to-Noise Ratio

The signal-to-noise ratio (SNR) is a measurement of the difference between a recorded signal and noise levels. A high SNR is always the goal.

The maximum signal-to-noise ratio of digital audio is determined by the number of bits per sample. In 16-bit audio, the signal to noise ratio is 96 dB, while in 8-bit audio, the ratio is 48 dB. However, in practice, this SNR is never achieved, especially when using low-end electronics.

Small Computer Systems Interface (SCSI)

A standard interface protocol for connecting devices to your computer. The SCSI bus can accept up to seven devices at a time including CD-ROM drives, hard drives and samplers.

SMPTE

SMPTE is the acronym for the Society of Motion Picture and Television Engineers (SMPTE). SMPTE timecode is used to synchronize time between devices. The timecode is calculated in Hours:Minutes:Seconds:Frames, where Frames are fractions of a second based on the frame rate. Typical frame rates for SMPTE timecode can be 24, 25, 29.97 or 30 frames per second, depending on your local standards.

SMPTE Drop Frame Timecode

A method of measuring time in video. Drop frame involves skipping two frame numbers (no frames are actually dropped) every ten minutes to compensate for the difference between NTSC 29.97 fps video and 30 frame counts per second.

Telecine

The process of creating 30 fps video (television) from 24 fps film (cinema). See *inverse telecine* and *pulldown*.

Tempo

Tempo is the rhythmic rate of a musical composition, usually specified in beats per minute (BPM).

Time Format

The format in which Vegas software displays the ruler and selection times. These include: time, seconds, frames and all standard SMPTE frame rates.

Time Signature

See Beats Per Measure.

Timecode

For more information, see [Timecode](#) on page 324.

Track

A discrete timeline for audio or video data. Events are placed on tracks and determine when sound or images start and stop. Multiple audio tracks are mixed together to give you a composite sound that you hear. Multiple video tracks are composited on top of each other to create the final video output.

Track List

The track list appears at the left side of the Vegas workspace and contains the master controls for each track. From here you can adjust track volume or transparency, add track effects, mute or solo tracks, and reorder tracks.

Track View

The track view, or timeline, is the space events appear on tracks.

μ -Law

μ -Law (mu-Law) is a companded compression algorithm for voice signals defined by the Geneva Recommendations (G.711). The G.711 recommendation defines μ -Law as a method of encoding 16-bit PCM signals into a nonlinear 8-bit format. The algorithm is commonly used in European and Asian telecommunications. μ -Law is very similar to A-Law, however, each uses a slightly different coder and decoder.



Undo Buffer

This is the temporary file created before you do any processing to a project. This undo buffer allows the ability to revert to previous versions of the project if you decide you don't like changes you've made to the project. This undo buffer is erased when the file is closed or when you choose **Clear Edit History** from the **Edit** menu.

Undo/Redo

These commands allow you to change a project back to a previous state when you don't like the changes you have made, or reapply the changes after you have undone them. The ability to undo/redo is only limited by the size of your hard drive. See Undo Buffer.

Undo/Redo History

A list of all of the functions that have been performed to a file that are available to be undone or redone. The undo/redo history gives you the ability to undo or redo multiple functions. To display the history list, click the down-arrow on the Undo () or Redo () button.

Video for Windows (AVI)

See AVI.

Virtual MIDI Router (VMR)

A software-only router for MIDI data between programs. Vegas software uses the VMR to receive MIDI timecode and send MIDI clock. No MIDI hardware or cables are required for a VMR, so routing can only be performed between programs running on the same PC.

WAV

A digital audio file format developed by Microsoft and IBM. One minute of uncompressed audio requires 10 MB of storage.

Waveform

A waveform is the visual representation of wave-like phenomena, such as sound or light. For example, when the amplitude of sound pressure is graphed over time, pressure variations usually form a smooth waveform.

Waveform Display

A section inside of the Trimmer window or on an audio event that shows a graph of the sound data waveform. The vertical axis corresponds to the amplitude of the wave. For 16-bit sounds, the amplitude range is -32,768 to +32,767. For 24-bit sounds, the range is -8,388,607 to +8,388,607. The horizontal axis corresponds to time, with the left-most point being the start of the waveform. In memory, the horizontal axis corresponds to the number of samples from the start of the sound file.

Zero-crossing

A zero-crossing is the point where a fluctuating signal crosses the zero amplitude axis. By making edits at zero-crossings with the same slope, the chance of creating glitches is minimized. Vegas software simulates zero crossings by applying short (10 mS default) fades to trimmed audio.

Zipper noise

Zipper noise occurs when you apply a changing gain to a signal, such as when fading out. If the gain does not change in small enough increments, zipper noise can become very noticeable. Vegas software fades are accomplished using 64-bit arithmetic, thereby creating no zipper noise.

Index

Numerics

- 5.1 Surround Plug-In Pack, 186
- 5.1 Surround, *See Surround*

A

- A/B roll, See Tracks, Track layers*
- Add channels panning model, 110, 181
- Adding empty tracks, 105
- Adding media to a bin, 44
- Alpha channel, 227
 - In images, 190, 192
 - Selecting type for media file, 190
- Animation, 210
- Arming tracks to record, 53, 165
- ASR, *See Envelopes*
- Assignable effects, 150–152, 153
 - Assigning tracks to, 111, 151
 - Automation, 121
 - Routing to busses, 152
 - Volume adjustment, 111, 151
 - Volume envelope, 126
- Attributes
 - Copying from one event to another, 137
- Audio CD tab, 292
- Audio channels, 136
- Audio Device preferences, 297
- Audio Display preferences, 300
- Audio editor program, 85–87
 - Opening from Trimmer, 100
 - Opening from Vegas, 87
 - Setting up, 85
- Audio effects, 153–160
 - Adding via Plug-in Chooser dialog, 154
 - Adding via Plug-Ins window, 155
 - Assignable effects, 150–152
 - Automation, 122
 - Bypassing plug-ins, 157
 - Creating a plug-in chain, 154
 - Plug-Ins window, 25
 - Rearranging chain order, 156
 - Removing plug-ins from chain, 157
- Audio preferences, 297
 - Advanced control settings, 298
 - Playback buffering slider, 298
- Audio property settings, 291
- Audio proxy files, 322
- Audio tab, 291
- Auto-crossfades, converting to transitions, 232
- Automating
 - Mixer controls, 152
 - Surround panning, 182–185
- Automation
 - Assignable effects automation, 121
 - Bus automation, 122
 - Composite level automation, 124
 - Editing envelopes, 126
 - Hiding envelopes, 128
 - Latch mode, 130
 - Modes, 130
 - Motion blur automation, 125
 - Mute automation, 119
 - Recording, 130
 - Removing envelopes, 128
 - Showing or hiding controls, 119
 - Touch mode, 130
 - Track automation, 119
 - Track effect automation, 122
 - Volume and panning automation, 120
- Autosaving, 271

AVI

- Bit depth, 278
- Channels, 278
- Creating a movie, 57
- Format, 272, 278
- Frame rate, 277
- Frame size, 276
- Sample rate, 278
- Template, 276
- Video compression, 277

B

- Balance panning model, 110, 181
- Bézier masks, 189, 223
- Bins, media, 44
 - adding media, 44
 - adding recorded files automatically, 45
 - creating, 44
 - deleting media, 45
 - searching, 45
- Blue screening, 228
- Burning 5.1-channel audio to DVD, 186
- Burning audio CDs, 305
 - Adding pauses between tracks, 308
 - Creating a CD layout, 307
 - Disc-at-once burning, 305, 311
 - Exporting a track list, 310
 - Importing CD Architect files, 306
 - Marking tracks and indices, 308
 - Settings and preferences, 306
 - Track-at-once burning, 305, 310
- Burning CDs
 - proper use of software, 314
- Burning video CDs, 312
- Bus automation, 122
- Bus tracks, 152
- Busses, 111, 112, 145–149
 - Adding to project, 145
 - Adjusting for clipping, 148
 - Adjusting volume, 148
 - Assigning plug-ins to, 153
 - Assigning tracks to, 53, 111, 149
 - Automating parameters, 122
 - Automation, 122
 - Bus send volume envelopes, 126
 - Controls, 145
 - Deleting from project, 147
 - Meter resolution, 148
 - Muting, 148
 - Naming/renaming, 149
 - Panning, 179
 - Routing to hardware, 147
 - Soloing, 149

Bypassing

- Audio plug-ins, 157
- Video plug-ins, 208

C

- Capturing images
 - From a scanner, 42
 - From the Video Preview window, 191
- Capturing Video
 - Recapturing offline clips, 42
- Capturing video, 42
- CD
 - Burning audio CDs, 305
 - multimedia, 314
- CD Architect files, 306
- CD layout bar, 20
- CD Settings tab, 300
- CDs
 - video, 312
- Channels, audio, 136
- Checkerboard, 211
- Child tracks (compositing), 212, 221
- Chromakeying, 228
 - Multiple keys, 229
- Chrominance
 - monitoring, 260
- Clean up prerendered video, 256
- Clearing the edit history, 78
- Closed captioning, 193–196
 - Adding from a script, 194–196
 - Adding line-by-line, 194
 - Displaying, 196
- Color
 - Time Display window, 290
 - Track, 107
- Color channels, 259
- Color gradient event, 211
- Color key, 228
- Color levels
 - monitoring, 262
- Command markers, 82
 - Closed captioning, 193–196
 - Command bar, 19
 - Editing, 84
 - Inserting, 84
 - Scott Studios, 83
- Composite level automation, 124
- Composite level envelope, 126
- Composite level slider, 52, 112, 124, 215

- Composite mode
 - Setting default, 114
- Compositing, 212–215
 - Compositing modes, 52, 213–215
 - parent/child tracks, 212, 221
- Constant power panning model, 110, 181
- Contrast
 - monitoring, 262
- Control surface setup, 303
- Converting format, *See* Rendering
- Copying events, 63
 - Event attributes, 137
 - Time and events, 64
 - Time selections, 64
- Creating a movie, 57, 271–278
- Creating a multimedia CD, 314
- Creating bins, 44
- Creating DVD with DVD Architect, 186
- Credit roll event, 211
- Credits, 192
- Cropping video, 187–189
 - Copying and pasting cropping settings, 137
 - Plug-in processing order, 209
- Crossfades, 75–77, 231
 - Automatic, 75
 - Curve types, 76
 - Manually setting, 76
 - Overlapping files added to timeline, 191
 - Sliding, 76
 - Video, 231
- Cursor indications, 32
- Customizing DVD Architect
 - toolbar, 292
- Customizing keyboard shortcuts, 302
- Customizing Vegas, 287–296
 - Frame number display, 287
 - Grid spacing, 289
 - Preferences, 294–302
 - Project properties, 291
 - Rendering settings, 275
 - Ruler, 287
 - Time Display window, 289–290
 - Toolbar, 18
 - Video Preview window, 253
- Cuts, 231
 - Converting to transitions, 234
- Cutting events, 64–65
 - Ripple mode, 64
 - Time and events, 65
 - Time selections, 65

D

- Deleting
 - Busses, 147
 - CD layout bar markers, 309
 - Command markers, 85
 - Envelope points, 127
 - Events, 72
 - Keyframes, 238
 - Markers, 80
 - Regions, 81
 - Takes, 95
 - Tracks, 106
- Deleting media from a bin, 45
- Digital multitrack setup, 164
- DirectX plug-ins, 153, 205
- Disable resample, 135
- Disc-at-once CD burning, 305, 311
- Duplicating
 - Events, 67
 - Generated media events, 212
 - Keyframes, 238
 - Tracks, 106
- DV capture cards, 296, 326
- DV format, 198
 - Out-of-range colors, 200
 - Selecting source media for, 199
 - Setting project properties for, 199
 - Templates for, 199
- DVD
 - burning 5.1-channel audio, 186
 - creating with DVD Architect, 186
- DVD Architect, 186
- Dynamic RAM video previews, 256

E

- Edge trimming, 67
- Edit Decision Lists (EDL), 198
- Edit Details window, 24, 101
 - Audio CD track list category, 102
 - Closed captioning, 194–196
 - Commands category, 102
 - Customizing, 104
 - Displaying, 102
 - Edit functions, 101
 - Editing a CD layout, 310
 - Events category, 103
 - Markers category, 103
 - Regions category, 103
 - Selected events category, 103
- Edit history, clearing, 78
- Editing audio in external editor, 87

- Editing events, 63
- Editing tools
 - Envelope, 140
 - Selection, 60
 - Zoom, 50
- Effects
 - fine-tuning with split-screen previews, 257
- Effects, *See Plug-Ins*
- Empty events, 67
- Envelope Edit Tool, 128, 140
- Envelopes, 126–129, 137–141
 - Adding points, 126
 - ASR, 137
 - Changing fade curves, 127
 - Deleting from track(s), 128
 - Deleting points, 127
 - Event envelopes, 137–141
 - Fade in and out, 138, 139
 - Fade types, 138, 139
 - Hiding on track(s), 128
 - Mixer controls, 152
 - Moving points, 127
 - Opacity, 139
 - Ripple editing, 74
 - Track envelopes, 126–129
 - Velocity, 139
 - Video, 138
 - Volume (event), 137
 - Volume (track), 126
- Equipment setup for recording, 163–164
 - Basic, 163
 - mixer, 164
 - With digital multitrack, 164
 - With MIDI option, 164
- Event editing, 63
- Event properties
 - Copying and pasting, 137
 - Displaying names, 95
 - Name, changing, 95
 - Pitch shifting, 91
- Event switches, 133–135
 - Copying and pasting, 137
 - Invert phase, 134
 - Lock, 133
 - Loop, 133
 - Maintain aspect ratio, 135
 - Mute, 133
 - Normalize, 134
 - Reduce interlace flicker, 135
 - Resample, 135
- Event takes, 94
 - Adding files as, 94
 - Changing active, 94
 - Deleting, 95
 - Displaying names of, 95
 - Previewing, 95
 - Recording audio as new, 167
 - Renaming, 95
 - Selecting, 94
- Events, 48
 - adding transitions, 233
 - Channels, 136
 - Copying, 63
 - Copying and pasting attributes, 137
 - Crossfading, 75–77, 191, 231
 - Cutting, 64
 - Defined, 39
 - Deleting, 72
 - Duplicating, 67
 - edge trimming with keyboard, 69
 - Editing, 63
 - Empty, 67
 - Envelopes, 137–141
 - Fade in and out, 138
 - Grouping, 141–142
 - Moving by small increments, 49
 - Moving in time, 48
 - Moving multiple, 49
 - Moving single, 48
 - Name, changing, 95
 - Pasting, 65, 66
 - Pitch shifting, 91
 - Placing, 46, 47
 - Playback rate, 136
 - Recording into, 168
 - Reversing, 100
 - Selecting multiple, 60
 - Selecting with time, 62
 - Shifting the contents of, 71
 - Shuffling, 75
 - Sliding, 72
 - Slipping, 71
 - Slip-trimming, 71
 - Snapping, 89–90
 - Splitting, 69–71
 - Switches, 133–135
 - Trimming, 67
 - Undersample rate, 136
 - viewing media markers, 100
- Expand track keyframes, 52
- Expand track layers, 234
- Explorer window, 22
 - Transport bar, 40
- External Control & Automation Preferences, 303
- External monitor, 266–267, 296

F

- Fade in and out, 138
- Fade to color, 126
- Fader
 - Assignable effects, 112
 - Bus send, 112, 149
 - Pan, 110
 - track, 109
- Fading in/out
 - Mixer controls, 152
- Field order, 201, 322
- Filters, *See Video effects*
- Focus, 59
- Force resample, 135
- Frame
 - freeze, 68, 134, 140
- Frame numbers, 287
- Frame-by-frame cursor movement, 59
- Freeze frame, 68, 134, 140

G

- General editing, 59–87
 - Event vs. file, 48
- General preferences, 294
- Generator
 - Adding, 211
 - Duplicating, 212
 - window, 25
- Generic control surface setup, 304
- Glossary, 327–338
- Glow, 248
- Grid lines
 - Safe areas, 258
 - Snapping events to, 89
 - Spacing, 289
- Grouping events, 141–142
 - Adding to groups, 142
 - Clearing groups, 142
 - Creating new groups, 141
 - Moving grouped events, 49
 - Removing events from a group, 142
 - Selecting events in groups, 142
 - Suspending grouping, 142

H

- Hardware
 - Routing surround to, 175
 - Setting up for surround, 174

- Hiding/showing
 - Bus tracks, 152
 - Toolbar, 292
- Histogram, 262
- Hold keyframe, 239

I

- IEEE-1394 DV capture cards, 15, 42, 199, 266, 284, 296, 326
- Ignore event grouping, 142
- Image masks, 221
- Images
 - Automatically crossfading, 191
 - Capturing in Vegas, 191, 254
 - Correcting for DV pixel aspect ratios, 190
 - Creating for use in Vegas, 190
 - Creating masks from, 221
 - Creating titles from, 192
 - Default length, 191
 - Working with, 190
 - Zooming in on, 241
- Importing
 - Audio CD tracks, 43
 - CD Architect files, 306
 - Media, 41
 - Scanned images, 42
 - Still image sequences, 44
- Inserting
 - Command markers, 84
 - Empty events, 67
 - Markers, 79
 - Media, 46
 - Regions, 80
 - Time, 67
 - Video files with associated audio, 47
- Inserting empty tracks, 105
- Installation, 16
 - System requirements, 15
- Interlace, 322
 - Deinterlacing, 201
 - Field order, 201, 277, 322
 - Reduce interlace flicker, 135
- Inverting
 - Audio event, 134
 - Audio track, 113
 - Invert track phase, 53
- Isolate channels, 225
- Isolating color channels, 259

K

- Keyboard commands, 26–31
 - Cursor placement, 27, 59, 62
 - Edit, 27
 - Event, 28
 - Miscellaneous, 31
 - Playback, 26
 - Project file, 26
 - Selection, 28
 - Track view, 30
 - Trimmer window, 30
 - View, 28
 - Window view, 26
- Keyboard preferences, 302
- Keyboard shortcuts, customizing, 302
- Keyframe animation, 210, 237
 - Event panning and cropping, 241
 - Generated text, 244
 - Track motion, 247
 - Video effects, 243
- Keyframe controller, 237
 - Navigating, 238
- Keyframes, 182–185
 - Adding, 238
 - Changing relative spacing, 239
 - Deleting, 238
 - In track view, 52, 240
 - Interpolation curves, 239
 - Modifying, 238
 - Ripple editing, 74
- Keying, 228

L

- Labeling busses, *See Naming busses*
- Labeling tracks, *See Naming tracks*
- Level slider, *See Composite level slider*
- LFE channel, 173, 176
- Locking events, 133
 - To track envelopes, 129
 - To track keyframes, 240
- Loop playback, 62
- Looping events, 133
- Luminance, 227
 - monitoring, 261

M

- Mackie Control Universal, 303
- Main window, 18
- Make compositing child, 52, 213, 221, 222
- Marker bar, 19

Markers

- CD layout markers, 85
 - Command markers, 82
 - Deleting, 80
 - Inserting, 79
 - media, adding, 99
 - media, viewing, 100
 - Moving, 79
 - Navigating, 79
 - Renaming, 79
 - Ripple editing, 74
 - Snapping, 89
- Markers and regions, 78–85
 - Snapping events to, 89
- Masks, 220–229
 - Bézier, 189, 223
 - Fine tuning, 225
 - Image, 221
 - Mask generator, 226
 - Video, 222
- Match media settings, 38, 201
- Media bin
 - adding recorded files automatically, 45
- Media bins, 44
 - adding media, 44
 - creating, 44
 - deleting media, 45
 - searching, 45
- Media files
 - Auto preview setting, 40
 - Inserting, 46
 - Previewing, 40
 - Properties, 202
- Media generator
 - Adding, 211
 - Duplicating, 212
 - window, 25
- Media generators, 211–212
- Media markers
 - adding, 99
 - viewing in event, 100
- Media Pool, 23, 41
 - Adding media, 41
 - Adding still image sequences, 44
 - Capturing video, 42
 - Extracting CD audio, 43
 - Getting images, 42
 - Replacing media in events, 41
- Media region
 - viewing in event, 100
- Media regions
 - adding, 99
- Metronome, 167, 297
 - MIDI clock output, 302

MIDI control surface setup, 304

MIDI timecode

- Input devices, 301
- Output devices, 301
- Time Display window, 290
- Triggering from, 170

Mixer, 22, 143

- Busses, 112, 145–149
- Preview fader, 144
- Toolbar, 144
- Viewing/hiding, 143

Mixer setup (external), 164

Mixer window

- Automating controls, 152
- Routing surround through, 175

Mixing

- Multiple tracks to a new track, 116
- Video tracks, 212–215

Monitoring

- chrominance, 260
- color content, 260
- color levels and contrast, 262
- luminance, 261
- RGB components, 263

Monitoring video with scopes, 259

Motion blur automation, 125

Mouse scroll-wheel shortcuts, 32, 50, 59

MTC, *See MIDI timecode*

Multimedia CD

- burning, 314

Multimedia controller

- scrubbing, 55

Multiple takes

- Previewing, 95
- Recording, 170
- Selecting among, 94

Multipurpose slider, 53, 110

- Assignable effects send level, 111, 112, 151
- Bus send level, 112, 149
- Panning, 110, 318

Mute automation, 119

Muting

- All audio or video tracks, 113
- Busses, 148
- Events, 133
- Mute button, 52, 53
- Tracks, 113

N

Naming

- Busses, 149
- CD layout markers, 309
- Markers, 79
- Regions, 81
- Takes, 95
- Tracks, 106

Noise texture, 211

Non-real-time event effects, 160

Normalize audio event, 134

O

OHCI 1394-IEEE cards, 15, 42, 199, 267, 284, 296, 326

Online help, 16

- Via the web, 17
- What'sThis? help, 17

Optimizing previews, 255–265

Ordering of effects, 156, 208

Organizing tracks, 107–108

Overlays

- Animating, 250
- Compositing modes, 213–215
- Masks, 220–229
- Position, 247
- Safe areas, 258
- Shadow, 247
- Transparency, 228

P

Pan type

- Setting track default, 114

Panning

- Pan types, 181
- Surround, 178

Panning automation, 120

Panning, audio

- Envelope, 126
- Multipurpose slider, 110
- Panning models, 110

Panning, video, 241

- Pan-and-scan effect, 242
- Plug-in processing order, 209

Parent media for subclips, 101

Parent/child tracks, 212, 221

Pasting

- Event attributes, 137
- paste insert, 66
- paste repeat, 66

Pasting events, 65–66

- Perfect Clarity (.pca) audio format, 273
- Phase inverting
 - Events, 134
 - tracks, 113
- Picture-in-picture effect, 250
- Pitch shifting, 91
 - Copying and pasting between events, 137
- Pixel aspect ratio, 201
 - Custom stream properties, 203
 - Render settings, 277
 - Still images, 190
- Placing media
 - As takes, 46
 - Dragging/dropping, 46
 - Multiple files, 46
 - Same track, 46
- Playback
 - Buffer control, 298
 - Event playback rate, 136
 - Interpolate cursor position control, 298
 - Keyboard shortcuts, 26
 - Position bias control, 298
 - Pre-roll buffer control, 298
 - Scrubbing, 55
 - Transport bar controls, 20
- Plug-in chain
 - Audio hierarchy, 34
 - Changing order, 156, 157, 208
 - Creating, 154, 206
 - Saving presets, 156, 210
- Plug-ins
 - Animating, 210
 - Audio, 153
 - Bypassing, 157, 208
 - Copying and pasting event plug-ins, 137
 - Events with panning/cropping, 209
 - Generators, 211–212
 - Keyframes, 210
 - Masks, 220–229
 - Media generators, 211–212
 - Modifying, 210
 - Ordering, 156, 208
 - Removing, 157, 209
 - Transitioning into, 243
 - Transitions, 231
 - Video, 205
 - Window, 25
- Post-edit rippling, 74
- Post-roll, 169
- PQ list, *See Track list*
- Preference settings, 294–302
 - Audio tab, 297
 - Audio tab, advanced settings, 298
 - CD Settings tab, 300
 - Editing tab, 299
 - General tab, 294
 - Sync tab, 301
 - Sync tab, advanced settings, 301
 - Video device tab, 296
 - Video tab, 296
- Preferences
 - Audio Device tab, 297
 - Display tab, 300
 - External Control & Automation tab, 303
 - Keyboard tab, 302
- Preparing video for broadcast
 - Safe areas, 258
- Preparing video for television
 - DV format guidelines, 198
- Prerendering video, 255
- Pre-roll, 169
- Preset chains, 159–160
 - Editing, 159
 - Organizing, 160
 - Saving from existing chains, 159
- Presets, saving, 156, 210, 236
- Preview
 - split screen, 257
- Preview fader
 - Adjusting for clipping, 148
 - Adjusting volume, 144
 - Hiding/viewing, 144
 - Meter resolution, 144
- Previewing
 - split-screen view, 257
- Previews, 54
 - Full-quality, 255
 - In media players, 56
 - Optimizing, 255
 - Prerendering, 255
 - Resolution, 255
 - Transitions, 235
- Printing to tape
 - from the timeline, 285
- Printing video
 - From the timeline, 284
 - From Video Capture, 284
- Project playback
 - Entire, 54
 - Media player, 56
 - Time selection, 54

Project property settings, 291–292
 Audio CD tab, 292
 Audio tab, 291
 Matching video settings of existing file, 38, 201
 Ruler tab, 292
 Summary tab, 292
 Video tab, 291

Projects
 Creating, 37
 Renaming, 39
 Rendering, 271–278
 Saving, 38, 269–271
 Saving as EDLs, 198

Proper use of software, 314

Properties
 Events, 136
 Media file, 202
 Project, 37, 291–292
 Track defaults, 114

Proxy files, audio, 322

Pulldown removal, 39, 295
 Configuring, 45

Punch-in, 66, 169

Q

Quantizing to frames, 89

Quick start, 37–57

R

RAM cache for previews, 256

RealMedia (.rm)
 commands, 83
 File format, 272
 file format, 57

Recapturing offline video clips, 42

Recording, 163–171
 Arming tracks, 165
 Into a time selection, 168
 Into an event, 168
 Into an event with time selection, 169
 Multiple takes, 170
 Previewing takes, 95
 Selecting track input devices, 166
 Specifying storage folder, 170–171
 Starting and stopping, 167
 Stereo, left, right channel options, 166

Red book CD burning, 305, 311

Redo/Undo commands, 77–78
 Clearing history, 78
 Multiple, 78

Region, 80

Regions
 Adding as takes, 99
 Deleting, 81
 Inserting, 80
 media, adding, 99
 media, viewing, 100
 Moving, 80
 Naming, 81
 Navigating to, 81
 Ripple editing, 74
 Selecting, 81

Registering Vegas, 16

Removing
 Events from a group, 142
 Plug-ins, 209
 plug-ins, 157
 Track envelopes, 128
 Velocity envelopes, 141

Renaming
 Busses, 149
 CD layout markers, 309
 Markers, 79
 Projects, 39, 270
 Tracks, 106

Rendering, 57, 271–278
 controls and templates, 275
 Custom settings, 275
 File formats, 57, 272
 Surround projects, 185
 To a new track, 116

Reordering tracks, 107

Resampling, 197–198
 At final render, 197
 Event, 135, 140, 197

Reversing a video event, 140

Reversing events, 100

RGB components, 263

Ripple editing, 66
 Automatically, 74
 Cutting, 64
 Deleting, 72
 Manually, 74
 Pasting, 65
 Post-edit rippling, 74
 Shuffling events, 75

Ruler, 19
 Offset, setting, 288
 Project property settings, 292
 Time formats, 288, 326

Ruler tab, 292

S

Safe areas, 258

- Saving a project, 38, 269–271
 - Autosaving, 271
 - Using Save As, 39, 270
 - With media files, 270
- Scopes
 - histogram, 262
 - RGB parade, 263
 - vectorscope, 260
 - video, 259
 - waveform, 261
- Scott Studio
 - Commands, 78, 83
 - File format, 40, 272
- Scribble strip, 52, 53, 106
- Scrolling, 50
- Scrubbing, 55–56
 - Keyboard, 56
 - Scrub control, 21, 55
 - Timeline, 56
 - with multimedia controllers, 55
- Searching media bins, 45
- Selecting
 - all members of a group, 142
 - Audio CD tracks, 309
 - Envelope points, 128
 - Events and a time range, 62
 - Events to the end of the track, 61
 - grouped events, 142
 - Media files, 40
 - Multiple events, 60
 - Range of events, 60
 - Regions, 81
 - Takes, 94
 - time range, 61
 - Tracks, 62
- SFAP files, 322
- Shadow, 247
- Shuffling events, 75
- Signal flow, 34–35
- Single session CD burning, 305
- Slide show, creating, 191
- Slider
 - Multipurpose, 110
- Sliding
 - Crossfades, 76
 - Events, 72
- Slipping events, 71
- Slip-trimming events, 71
- Smart resample, 135
- SMPTE timecode, 324
 - Changing, 288
- Snap offset, 90
- Snapping events, 89–90
 - Quantizing to frames, 89
 - Snap offset, 90
 - To a selection, 90
 - To grid lines, 89
 - To marker lines, 89
 - To the cursor, 90
- Solid color event, 211
- Soloing
 - Assignable effects chains, 150
 - Busses, 149
 - Solo button, 52, 53
 - Tracks, 114
- Sorting media with bins, 44
- Split-screen previews, 257
- Splitting, 69–71
 - All events at cursor, 70
 - Selected events, 70
 - Time selection, 70
- Status bar, 20, 117
- Streaming media commands, 83
 - RealPlayer, 83
 - Windows Media, 83, 193
- Stretching events, 93
- Subclips, 100
- Summary tab, 292
- Surround, 173–186
 - Automating panning, 182–185
 - Hardware setup, 174
 - Keyframes, 182–185
 - LFE channel, 173, 176
 - Panning, 178
 - Rendering, 185
- Surround Panner window, 180
- Switches, 133–135
 - Invert phase, 134
 - Lock, 133
 - Loop, 133
 - Maintain aspect ratio, 135
 - Mute, 133
 - Normalize, 134
 - Reduce interlace flicker, 135
 - Resample, 135
- Sync tab, 301
 - Advanced control settings, 301
- Synchronizing MIDI timecode, 164, 170
- System requirements, 15

T

- Takes, 94
 - Adding files as, 94
 - Deleting, 95
 - Displaying names of, 95
 - Placing media as, 46
 - Previewing, 95
 - Recording audio as new, 167
 - Renaming, 95
 - Selecting, 94
- Technical support, 15
- Test pattern
 - Creating when printing to DV tape, 285
 - Event, 211
- Text
 - Credit roll event, 211
 - Keyframing, 244
 - Media Generators window, 25
 - Text event, 211
 - Titles, 192
- Time compressing events, 93
- Time Display window, 19, 289–290
 - Changing color, 290
 - Changing time format, 289
 - MIDI timecode settings, 290
- Time selection, 61
 - Copying, 64
 - Cutting, 65
 - Recording into, 168
 - With events, 62
- Timecode
 - MIDI, 164, 170, 301–302
 - Video, 324
- Timeline
 - Adding media to, 46
 - Moving events along, 48
 - Playback on external monitor, 266–267
 - Print to DV tape from, 284
- Titles
 - Creating, 192
 - Fading, 193
 - Safe areas, 258
 - Text generator, 211–212
- Toolbar, 18
 - adding buttons, 293
 - customizing, 292
 - hiding/showing, 292
 - removing buttons, 293
 - reordering buttons, 293
- Track automation, 119–121
- Track automation envelopes, 126
- Track effects
 - Setting default, 114
- Track envelopes, 126–129
 - Adding points, 126
 - Changing fade curves, 127
 - Colors, 126
 - Deleting points, 127
 - Envelope Edit Tool, 128
 - Hiding on track(s), 128
 - Locking to events, 129
 - Moving points, 127
 - Removing from track(s), 128
 - Types, 126
- Track FX button, 52, 53
- Track list, 20, 52–53
- Track list (audio CD)
 - Creating from events, 308
 - Editing in Edit Details window, 310
 - Exporting, 310
- Track motion, 245–251
 - Button, 52
 - Glow, 248
 - Keyframes, 247
 - Picture-in-picture effect, 250
 - Position, 247
 - Shadow, 247
 - Shortcut menu, 246
- Track name, 52, 53
 - Changing, 106
- Track view, 20
- Track-at-once CD burning, 305, 310
- Tracks, 50, 105–117
 - Adding empty, 105
 - Arming for recording, 53
 - Assigning plug-ins to, 153, 206
 - Assigning to a bus, 53, 111, 149
 - Automating parameters, 119–121
 - Color, changing, 107
 - Compositing modes, 52, 213–215
 - Default properties, 114
 - Deleting, 106
 - Duplicating, 106
 - Height, changing, 108
 - Height, setting default, 114
 - inserting empty, 105
 - Making compositing child, 52, 221
 - Mixing to a single track, 116
 - Multipurpose slider, 53
 - Muting, 52, 53, 113
 - Naming/renaming, 106
 - Number, 52, 53
 - Organizing, 107–108
 - Panning, 178
 - Phase inverting, 53, 113
 - Reordering, 107
 - Resizing, 108
 - Scribble strip, 52, 53, 106
 - Selecting, 62
 - Soloing, 52, 53, 114

- Track effects, 52, 153–160, 205–210
 - Track FX button, 53
 - Track keyframes, 52, 240
 - Track layers, 234
 - Track motion, 52, 245–251
 - View buttons, 52, 53
 - View options, 108
 - Volume fader, 53, 109
- Transition
- adding to all selected events, 233
- Transitions, 231
- Adding, 232
 - Animating, 237
 - From auto-crossfades, 232
 - From cuts, 234
 - Modifying, 236
 - Using, 231
 - Window, 24
- Transparency, 139
- And overlays, 228
- Transport bar, 20, 54, 55
- Keyboard shortcuts, 26
- Triggering recording from MIDI timecode, 170
- Trimmer window, 22, 96–101
- Audio editor, opening from, 100
 - Events, placing on track, 97
 - Opening a file in, 96
 - Overview, 96
 - Regions and markers, adding, 99
 - Subclips, 100
 - Three-point editing, 98
 - Working with, 97
- Trimming, 67–68
- Adjacent events, 68
 - Beyond event edges, 68
 - events with keyboard, 69
 - selected events, 67
 - Time and event selection, 68
 - Time selection, 68
- Troubleshooting
- Audio, 317–318
 - Video, 317–326
- U**
- Undersample rate, 136
- Undo/Redo commands, 77–78
- Clearing history, 78
- V**
- Vectorscope, 260
- Vegas
- Installing, 16
 - Overview, 18–32
 - Registering, 16
- Velocity envelope, 139
- Video
- monitoring with scopes, 259
- Video Capture
- Capturing video with, 42
 - Printing to tape with, 284
 - Recapturing offline clips with, 42
- Video CDs
- burning, 312
- Video effects, 205–210
- Animating, 210
 - Keyframes, 210
 - Modifying, 210
 - Ordering, 208
 - Removing, 209
 - Window, 24
- Video masks, 222
- Video motion, *See Track motion*
- Video preview
- split-screen, 257
- Video previews
- Capturing images from, 191, 254
 - Dynamic RAM previews, 256
 - External monitor, 266–267
 - Optimizing, 255–265
 - Prerendering, 255
 - Previewing in a player, 265
 - Resolution, 255
 - Shortcut menu, 254
 - Window, 23
- Video property settings, 291
- Video scopes, 259
- histogram, 262
 - RGB parade, 263
 - vectorscope, 260
 - waveform, 261
- View buttons, 52, 53
- Viewing
- media markers, 100
 - media regions, 100
- Volume
- Assignable effects fader, 111, 151
 - Bus send fader, 149
 - Event envelopes, 137
 - Setting track default, 114
 - Track envelopes, 126
 - Track fader, 53, 109
- Volume automation, 120
- W**
- Wave64 (.w64) audio format, 273

Web site
 Accessing help, 17
 Metadata examples, 78
 Technical support, 15
 Troubleshooting resources, 267, 317, 326

What'sThis? help, using, 17

Window docking area, 21

Windows
 Surround Panner, 180

Windows Media streaming commands, 83

Z

Zoom Edit Tool, 50

Zooming, 50

