

# Chapter 4 – Signal Paths

The OXF-R3 system can be used to build a wide variety of signal paths with maximum flexibility from a basic default configuration. Creating configurations is simple. Signal paths created can be stored as Snapshots to be copied and/or recalled later.

## Chapter 4 Contents

<b>4-1</b>	<b>The Basic (Default) Signal Path .....</b>	<b>4-2</b>
<b>4-2</b>	<b>Mix-Down Signal Path with Processing Inserted .....</b>	<b>4-4</b>
<b>4-3</b>	<b>Mix-Down with Post Channel Fader Insert .....</b>	<b>4-6</b>
<b>4-4</b>	<b>Recording to a Multitrack .....</b>	<b>4-7</b>
<b>4-5</b>	<b>In-Line Channel Multitrack Recording Set-up .....</b>	<b>4-8</b>
<b>4-6</b>	<b>In-Line Channel with Insert Post Channel Fader (Monitor Function) .....</b>	<b>4-9</b>
<b>4-7</b>	<b>SEND 1 Pre Fader Headphones Feed .....</b>	<b>4-10</b>
<b>4-8</b>	<b>SEND 1 Post Fader Headphones Feed .....</b>	<b>4-11</b>
<b>4-9</b>	<b>Broadcast Mode .....</b>	<b>4-12</b>
<b>4-10</b>	<b>Channel Metering .....</b>	<b>4-15</b>
	4-10-1 Channel Meter Default .....	4-15
	4-10-2 Channel Meters to Input .....	4-15
	4-10-3 Send Monitor .....	4-16
	4-10-4 Return Monitor .....	4-16
	4-10-5 MULTI in Channel Path .....	4-17
<b>4-11</b>	<b>Dynamics Side-Chain Linking .....</b>	<b>4-18</b>
	4-11-1 Dynamics Side-Chain Link Right .....	4-18
	4-11-2 Dynamics Side-Chain Busses 1-4 .....	4-20
<b>4-12</b>	<b>Mixing to the Main Output Bus .....</b>	<b>4-22</b>
	4-12-1 Main Output Bus Set-up .....	4-24
	4-12-2 Channel Signal to the Main Output .....	4-26
<b>4-13</b>	<b>Multi-Stem Set-up .....</b>	<b>4-29</b>
	4-13-1 Multi-Stem Set-up Procedure .....	4-32
	4-13-2 Multi-Stem Monitor Path .....	4-36
	4-13-3 Multi-Stem Source Channels .....	4-40
	4-13-4 Stem Monitor Switching .....	4-48
	4-13-5 Stem Monitor Switching GUI Set-up .....	4-50
	4-13-6 Fold-Down Matrix GUIs .....	4-52

# 4-1 The Basic (Default) Signal Path

When the OXF-R3 is switched on, the system sets a default configuration as described in this section.

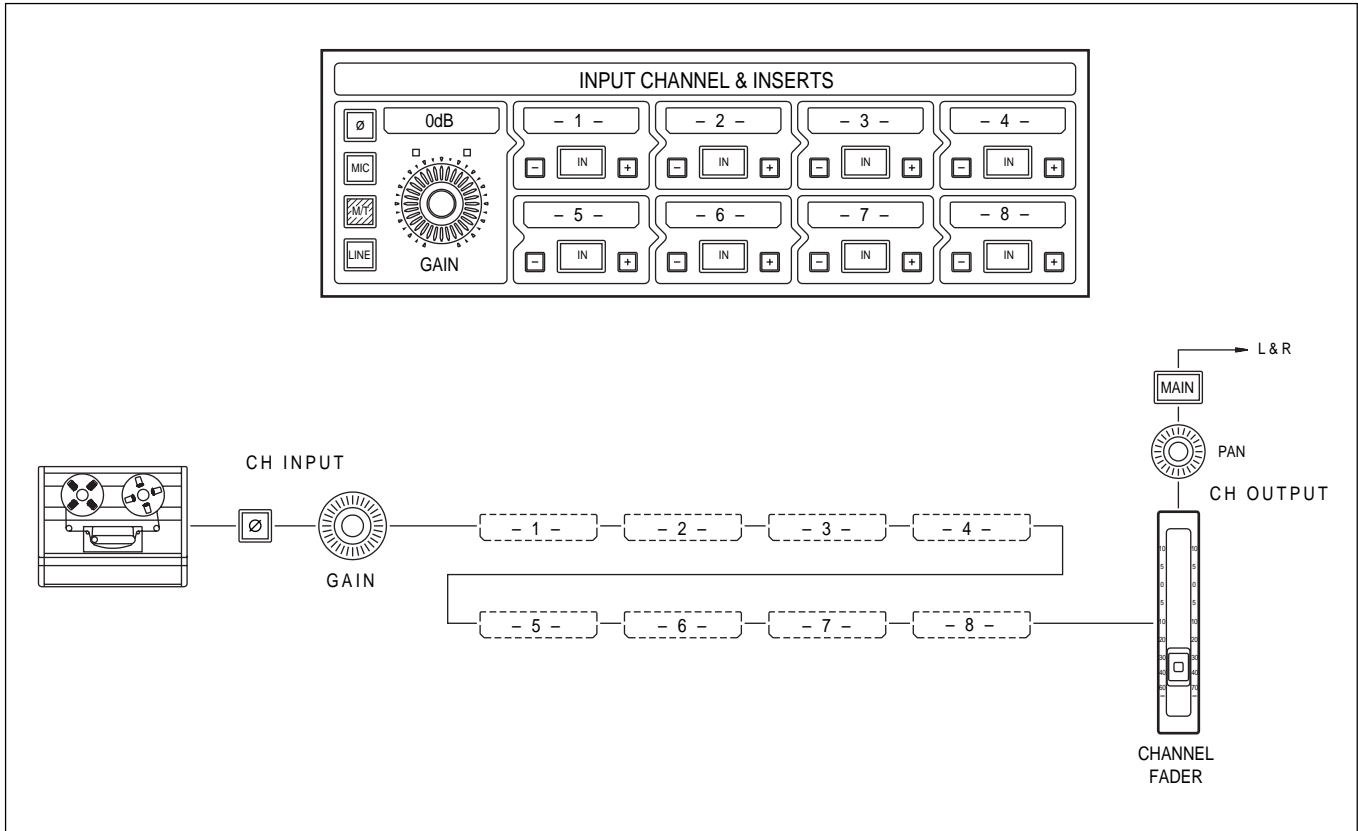

Default signal path

Signal paths are built using the controls on the Input Channel & Inserts section of the Input and Equaliser Module. Section 6-2-5 in Chapter 6 provides details of these controls.

In the default configuration shown, the M/T source button is selected and its signal feeds the multitrack phase reverse switch and gain control. The windows labelled 1 to 8 are available to insert processing elements such as EQ and dynamics but, in this default configuration, none are selected. From the phase reverse switch and input gain stage, the signal is passed directly on to the channel fader, through the channel pan and on to the MAIN L/R output bus.

**Note:**

*The MIC, LINE and M/T inputs each have their own individual phase switches and gain control stages.*

Moving on from the very simple (default) channel signal path, a selection of processing elements is available that can be inserted in any order. This is achieved using the eight small window sections, each with + and - buttons either side and an IN button. All available processing blocks in the Assignable Panel Area can be accessed in any of the windows by toggling the + and - buttons.

Functions currently supported are:

- **EQ**            5 BAND PARAMETRIC EQ with SHELIVING HF & LF (shelving is switchable)
- **FILT**        HIGH & LOW PASS FILTERS (6dB-36dB / octave in 6dB steps)
- **DYN**         GATE, EXPANDER, COMPRESSOR & LIMITER
- **INSERT**     EXTERNAL DEVICE INSERTION POINT
- **DELAY**      DIGITAL DELAY (up to 1.2s with Regen.)
- **MULTI**      INSERTION of MULTITRACK SEND, ROUTING & MONITOR PATHS
- **FADER**      CHANNEL FADER

The small arrow shape in the window outline points in the direction of the signal flow. Once the required function has been selected, press the IN button, which inserts that function into the signal path. It also becomes the master in/out switch for its function and can be automated.

The order of this signal path is defined according to the processes selected in each window. At any time, the order can be changed by de-selecting the IN button and toggling the name in the window to an alternative one. To clear a window, place the default box number back in the display, by pressing the + and - buttons simultaneously. Selection changes can only be made if IN buttons are not selected. If the same function is selected in two different windows at the same time, one of them will have an asterisk either side of the function name to inform the user that the process has already been selected in another window. Each function block can be used once per channel only. The following diagram shows an example of a signal flow through a channel configured for mix-down.

## 4-2 Mix-down Signal Path With Processing Inserted

For each channel, select **MIC**, **M/T**, or **LINE** as the mix-down source, depending on the situation. All input types may be cross-patched as desired via the LCD screens above the Channels areas. (Refer to Chapter 5, Control Screens for details).

As described previously, the Input Channel & Inserts section allows the setting up of processing functions in any order. The example configuration shown is a good starting point in a mix-down situation.

**Note:**

'MULTI' should not be selected in any window for multitrack mix-down. 'MULTI' is used in the channel path to create an in-line channel, described later in this chapter.

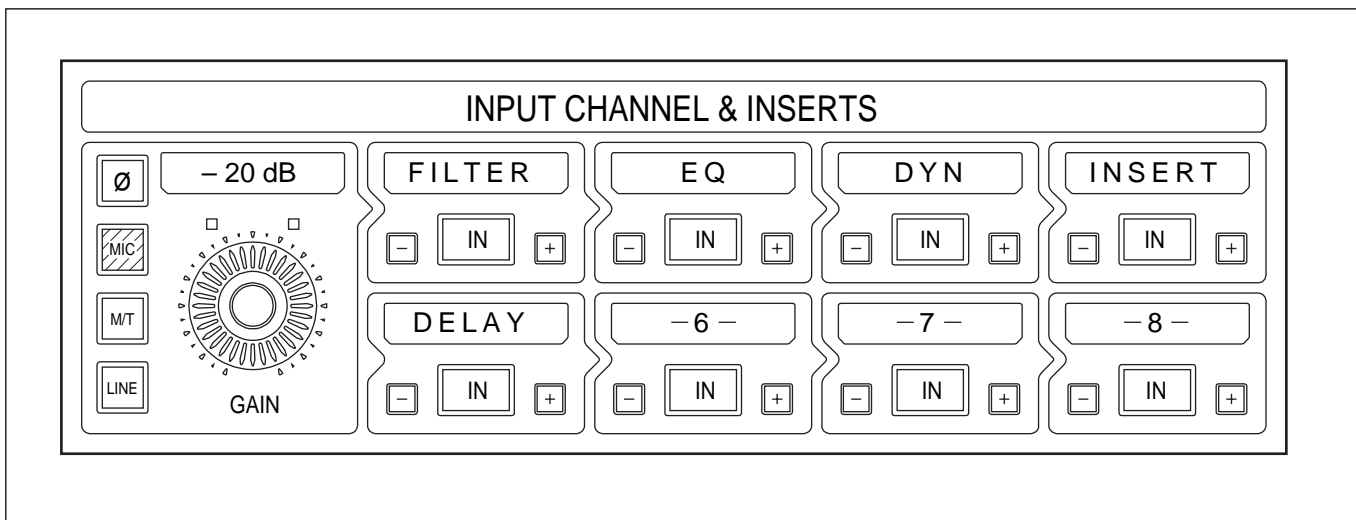

Mix-down channel path - example configuration

The fire-up default sets all channel outputs routed to the Main Output Bus via the **MAIN** button on the Routing panel. To feed the Main bus directly, make sure **MAIN** is selected on. Alternatively, channel outputs can be routed to Super Send Groups (SSGs) to group a selection of channels together.

To accomplish this, de-select **MAIN** and select an SSG at the Routing Panel. The output of the SSG can itself be routed directly to the Main Output Bus by selecting its **MAIN** button in the Multi-Format & Stereo Sub-Groups section, in the centre section.

Each SSG has its own knob for level control. Alternatively, on the Select To Faders panel in the SEL section, select SSGs 1-8 to set faders in the centre section to control SSG levels. The fire-up gain setting for SSGs is unity.

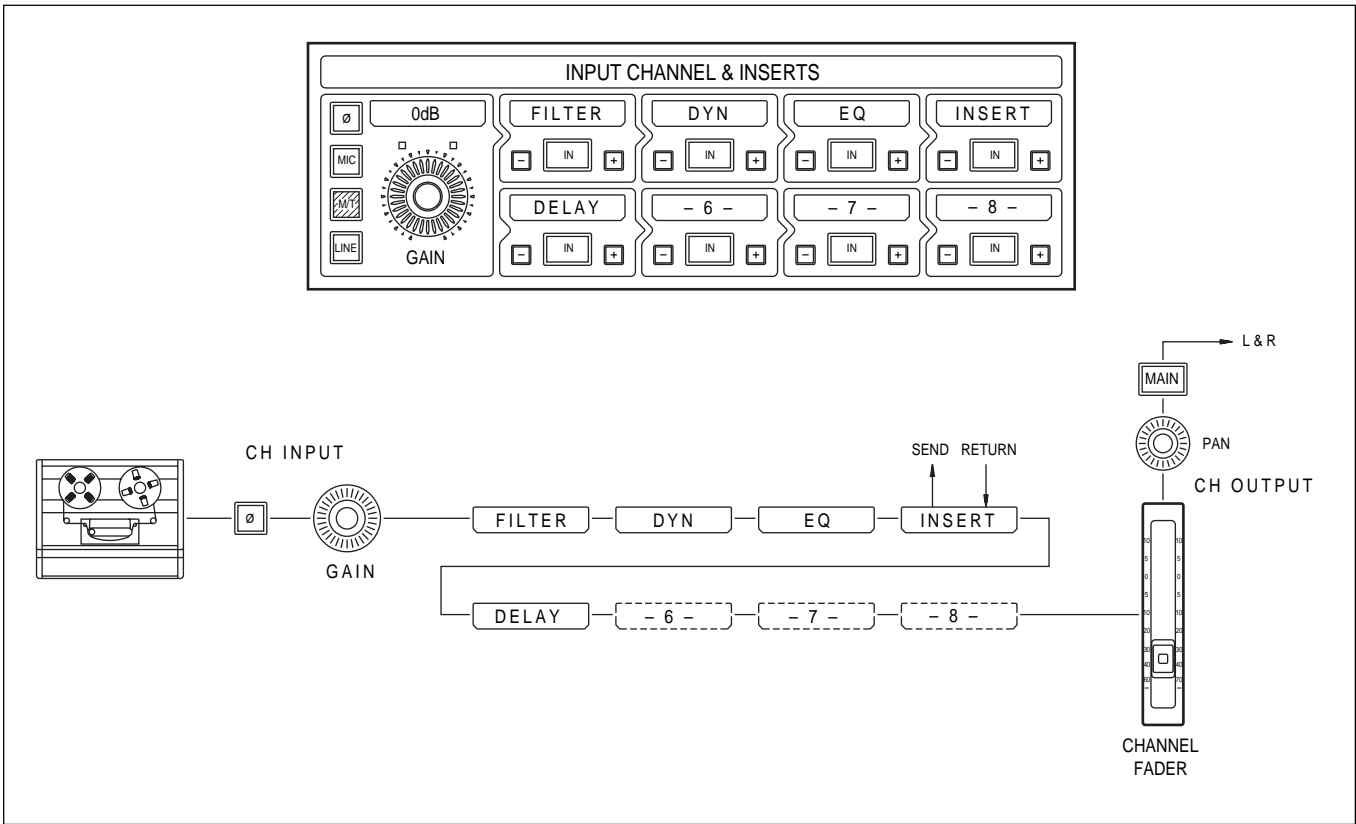

Signal flow for mix-down with processing in the channel path

## 4-3 Mix-down with Post Channel Fader Insert

The ability to swap functions easily enables the user to start with identical signal paths set up across the console using copy or snapshot functions. Then channels may be changed on an individual basis, according to the situation.

By selecting FADER in one of the eight windows, functions can be placed after the channel fader. The diagram shown is the same configuration as the previous mix-down set-up, but with the INSERT point placed after the fader, thus a post fader insert.

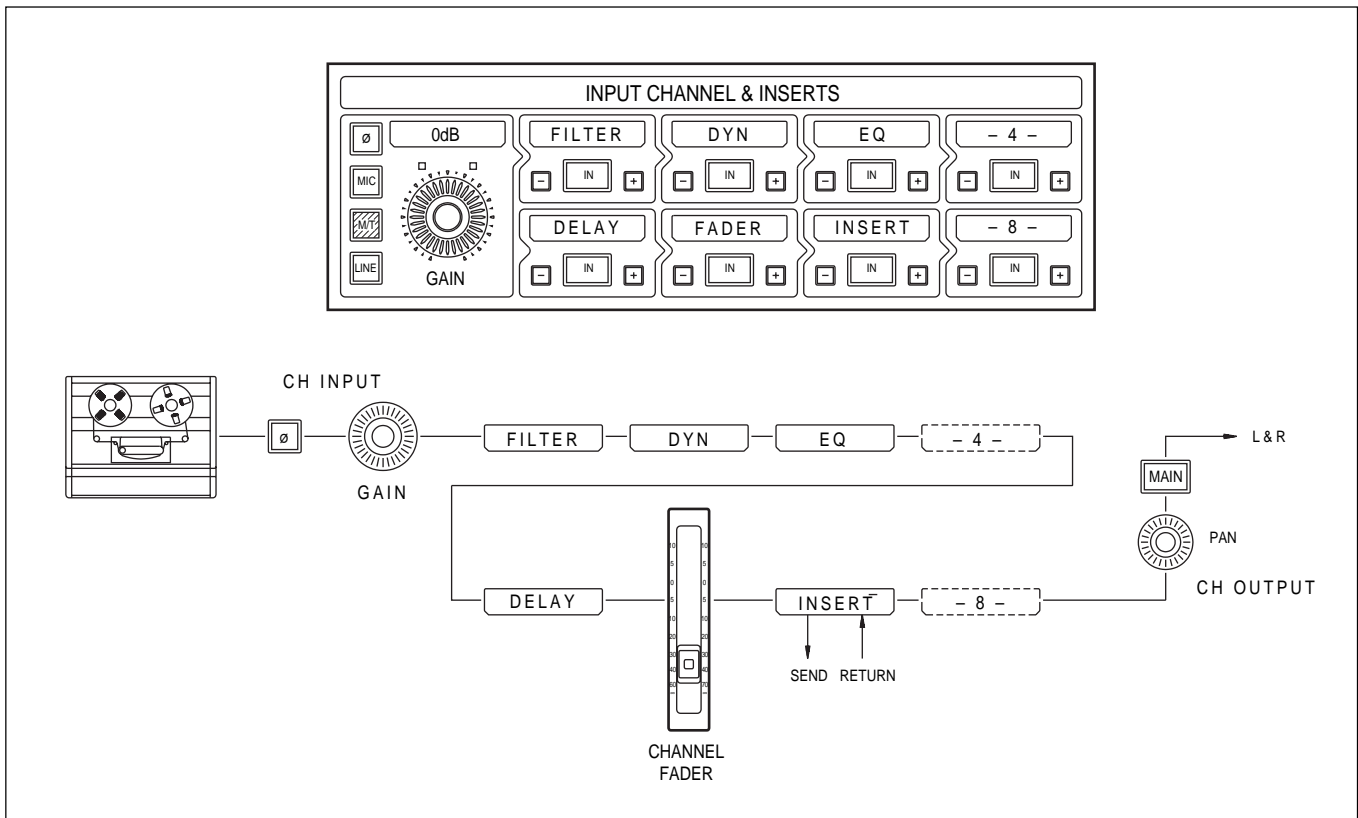

Mix-down with post channel fader insert

## 4-4 Recording to a Multitrack

To include the multitrack in the channel path, select MULTI in one of the eight windows in the Input Channel & Inserts section. This creates an in-line channel configuration, separating the channel input and monitor paths.

**HINT:** As a starting point, position the multitrack (MULTI) in window number 5. This allows windows 1 to 4 to be used for other functions such as EQ and dynamics so that they affect the recorded signal. Windows 6 to 8 are still available for inserting functions into the monitor path post multitrack. In other words, the top row of processing blocks forms the channel path, whilst the lower row is the monitor path.

Once one channel is set up, it can be copied to other channels across the console as required (*described in Chapter 7, Session Management™*).

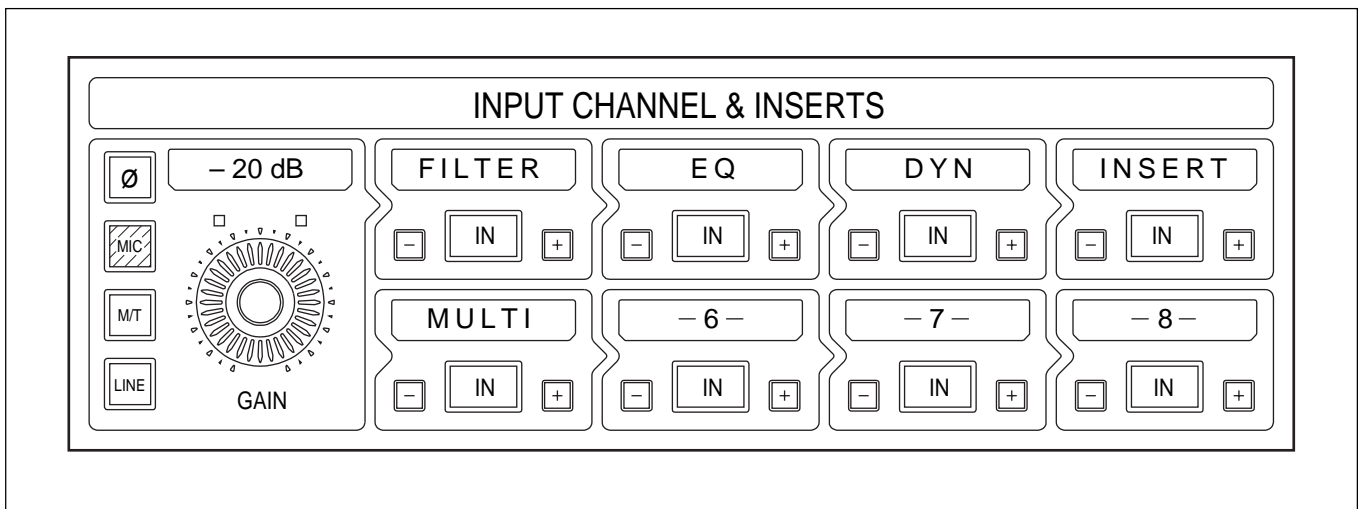

In-line channel multitrack recording configuration

All console inputs are available on the Channel Input Screens for cross patching. They are split into three different screen pages: MIC, LINE and M/T inputs.

(Refer to Chapter 5, Control Screens, for further details)

# 4-5 In-Line Channel Multitrack Recording Set-up

If FADER is not placed in any of the eight windows, it is automatically positioned after window number -8- equivalent to the monitor fader in an in-line console.

By selecting MULTI to one of the eight windows, the multitrack machine is inserted into the path and creates an In-Line channel. This then assigns the **SEND** and **RET** (urn) buttons, situated above the pans, to control whether the user is listening to the signal being sent to the tape or the return signal from the tape. The signal from tape is now sent to the monitor path via the channel fader. The **RECORD** button arms the tape machine into ready record for that track. The signal from the Mic input is sent to the routing via the send level on the Multitrack panel. This level can also be controlled by the fader by selecting M/T SEND. (See *SELECT TO FADERS* functionality in Chapter 6, *Technical Descriptions*).

Any function in the eight windows positioned before the word MULTI affects the signal recorded on tape. This is equivalent to the channel path of an in-line analogue console. The functions positioned after MULTI affect the monitor signal. For example, the diagram shows the word MULTI in window position 5. The effects of FILTER, EQ and INSERT are all being recorded. The DYNAMICS affect just the monitor signal.

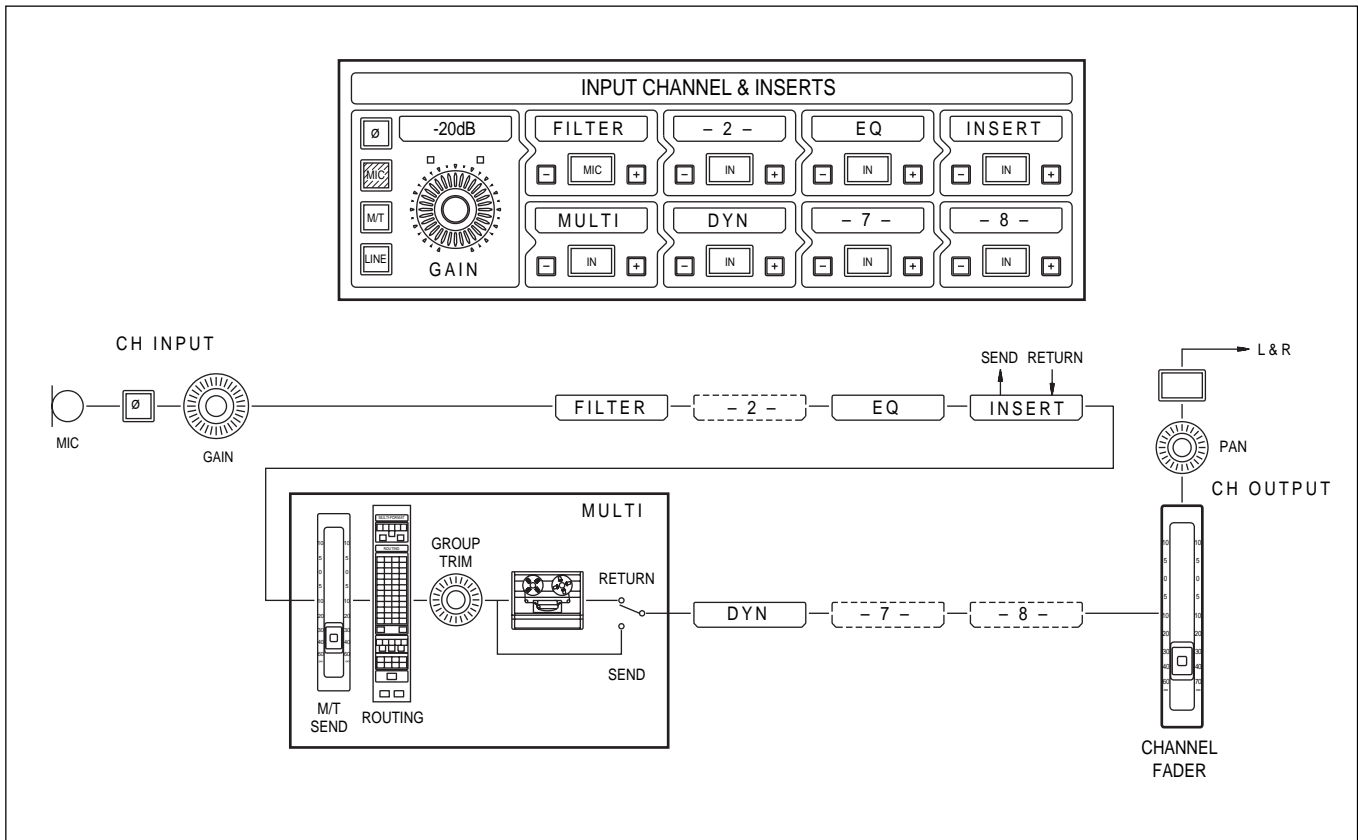

In-line channel for recording to a multitrack



# 4-6 In-Line Channel with Insert Post Channel Fader (Monitor Function)

As with the Mix-down examples shown previously, post fade functions can be configured in the same way during recording. The diagram shows the channel fader, which is controlling the monitor mix, with a post fade insert point.

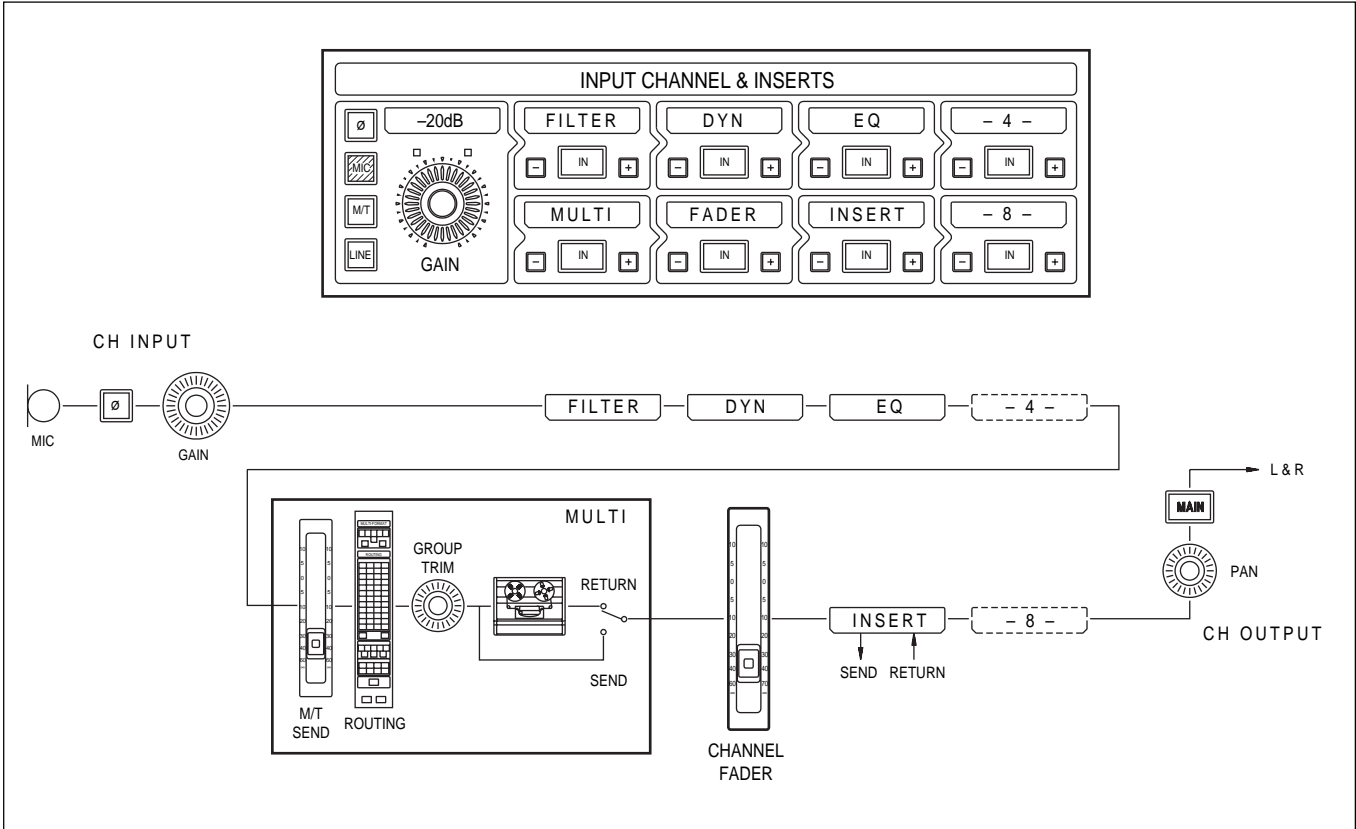

In-line multitrack with post fader insert in the monitor path

## 4-7 SEND 1 Pre Fader Headphones Feed

The diagram shows a typical Pre Fader headphone mix set-up, where a channel is configured in multitrack mode. SEND 1 is used to send a signal to headphones from the tape return signal. As the signal path indicates in the diagram, the headphones are positioned after the dynamics function sourced from the monitor path, pre fader.

To achieve this, on the upper section of the SENDS 1-24 panel, first make sure that SEND 1 is selected in the 'SELECT SOURCE FOR' display (upper right in the SENDS 1-24 panel). If not, use the large **+** and **-** buttons to select SEND 1. Then, in the left hand display window of the same panel, use the small **+** and **-** buttons to display - 8 - which will cause the **SELECT** button to light. Press the **SELECT** button and its light goes out to confirm the new source point. The source for SEND 1 bus is now fed from the output side of the channel path window displaying - 8 -.

This procedure may be used for each SEND bus, allowing the source point to be from any junction within the channel signal path, not just pre and post fader, as with the majority of analogue consoles.

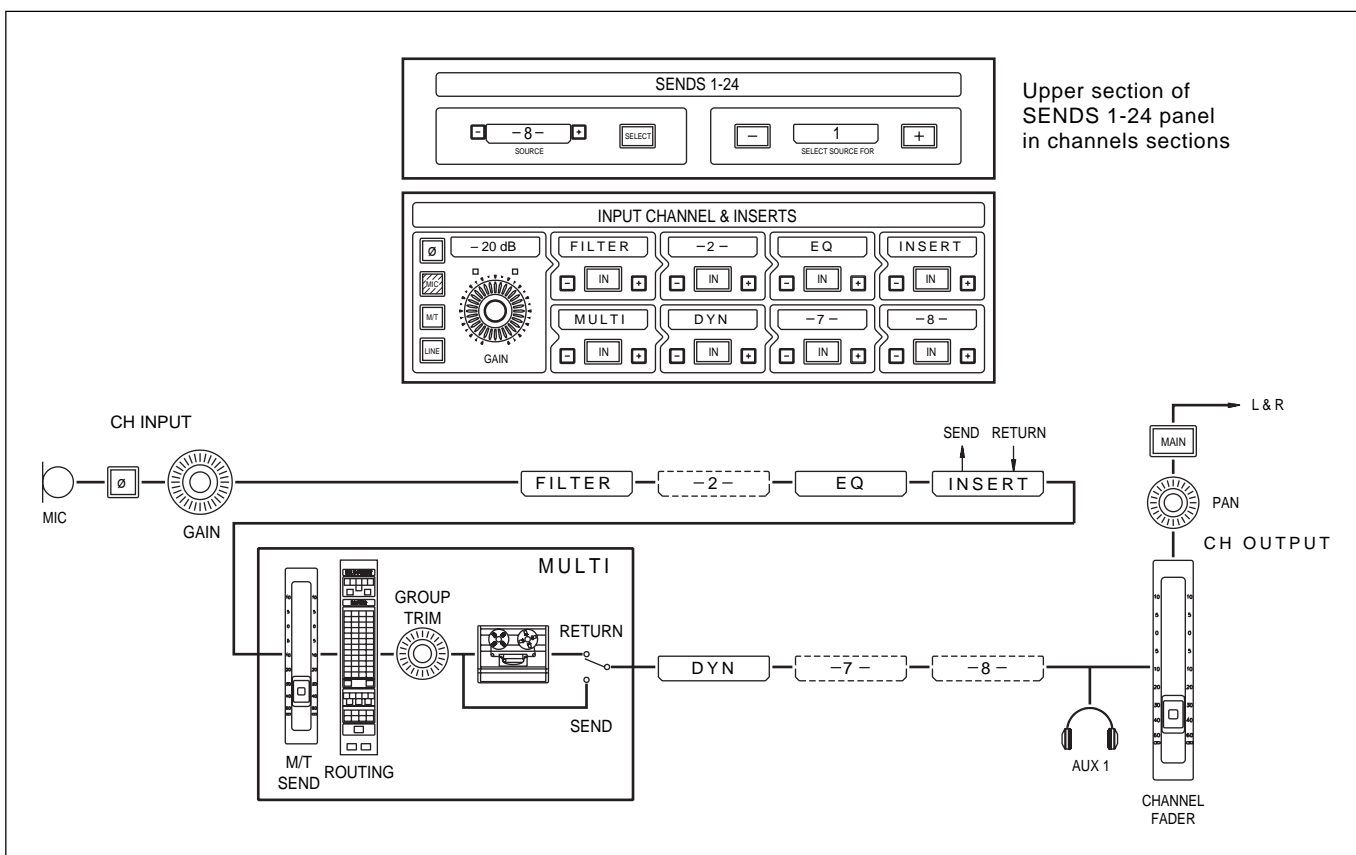

SEND 1 pre fader headphones feed

### Global select Source for all channels

First select the **ACCESS** button on the Main fader. Then select the appropriate source point in the **SOURCE** display in the upper right section of the SENDS 1-24 panel using the **+** and **-** buttons. Then press the **SELECT** button in the same section to set that source for all channels.

# 4-8 SEND 1 Post Fader Headphones Feed

To change the Pre Fader configuration to a Post Fader set-up, in the upper left SOURCE window of the SENDS 1-24 panel, simply toggle the SOURCE window to CH OUTPUT which will cause the **SELECT** button to light. Press **SELECT** and its light goes out confirming the new source point.

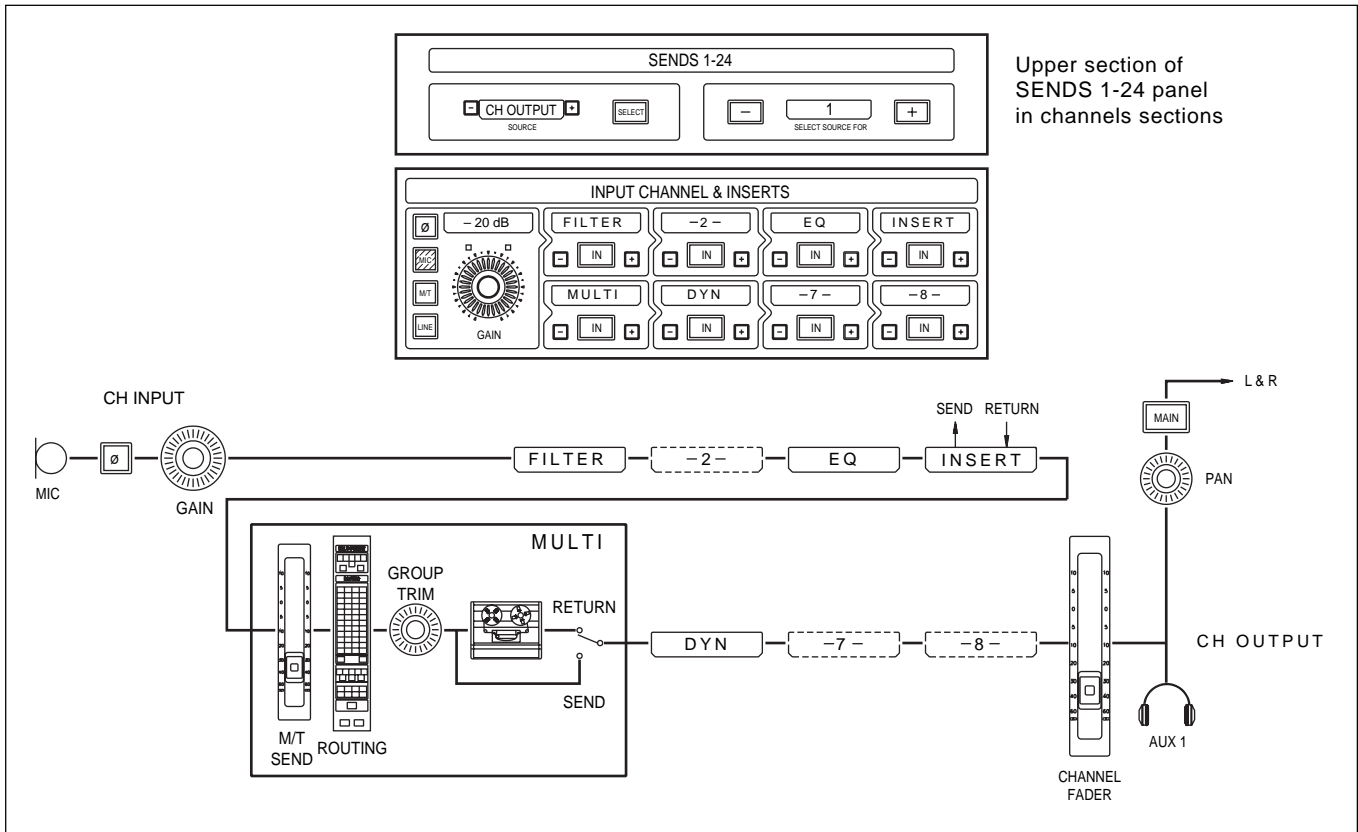

SEND 1 post fader headphones feed

## General

In 'Broadcast Mode' the operator is able simultaneously to:

- a) **Mix individual inputs to the Main Output Bus.**  
and:
- b) **Record a multitrack backup as a parallel operation.**

The multitrack output can be monitored separately via a stereo bus accessed by the External Source Selector in the Monitor panel in the centre section of the console.

## Setting up

At the Input Channel & Inserts panel, set the channel path as for Mix-down. Although a signal will be recorded to the multitrack, MULTI should not be selected in any of the 8 channel path windows. Select **MIC** or **LINE** and make sure **MAIN** is selected, at the Routing panel, for each channel required to feed the Main Output bus. Cross patch input sources via the LCD screens above the Channels sections.

*(Refer to Chapter 5, Control Screens for further details).*

To send the signal for each channel to the Multitrack as well as to the Mix bus:

1. Press the **ACCESS** button on the first channel to be routed. Route to the track required using the Routing panel.
2. On the Multitrack panel, toggle the **+** and **-** buttons either side of the window labelled SOURCE, below the Group Trim knob, until the desired source point is displayed. This can be taken from any of the 10 junctions within the signal path displayed on the Input Channel & Inserts panel. The source point for the multitrack feed will be taken from directly after the process displayed in the SOURCE window.

In the first diagram, CH INPUT is shown in the SOURCE window, enabling a 'clean' line level signal to be sent from a point immediately following the input stage.

In the second diagram, CH OUTPUT is shown in the SOURCE window, enabling a signal to be sent which includes the effects of all selected processing and adjustments made on the channel fader.

## Further Examples

With EQ selected in the SOURCE window, the feed to the multitrack would be affected by the high and low pass filters (FILTER), dynamics section (DYN) and the equaliser section (EQ), but not by the INSERT processing. If FILTER was the source, then just filters would affect the signal and so on. All processes affect the mix feeding the Main Output bus.

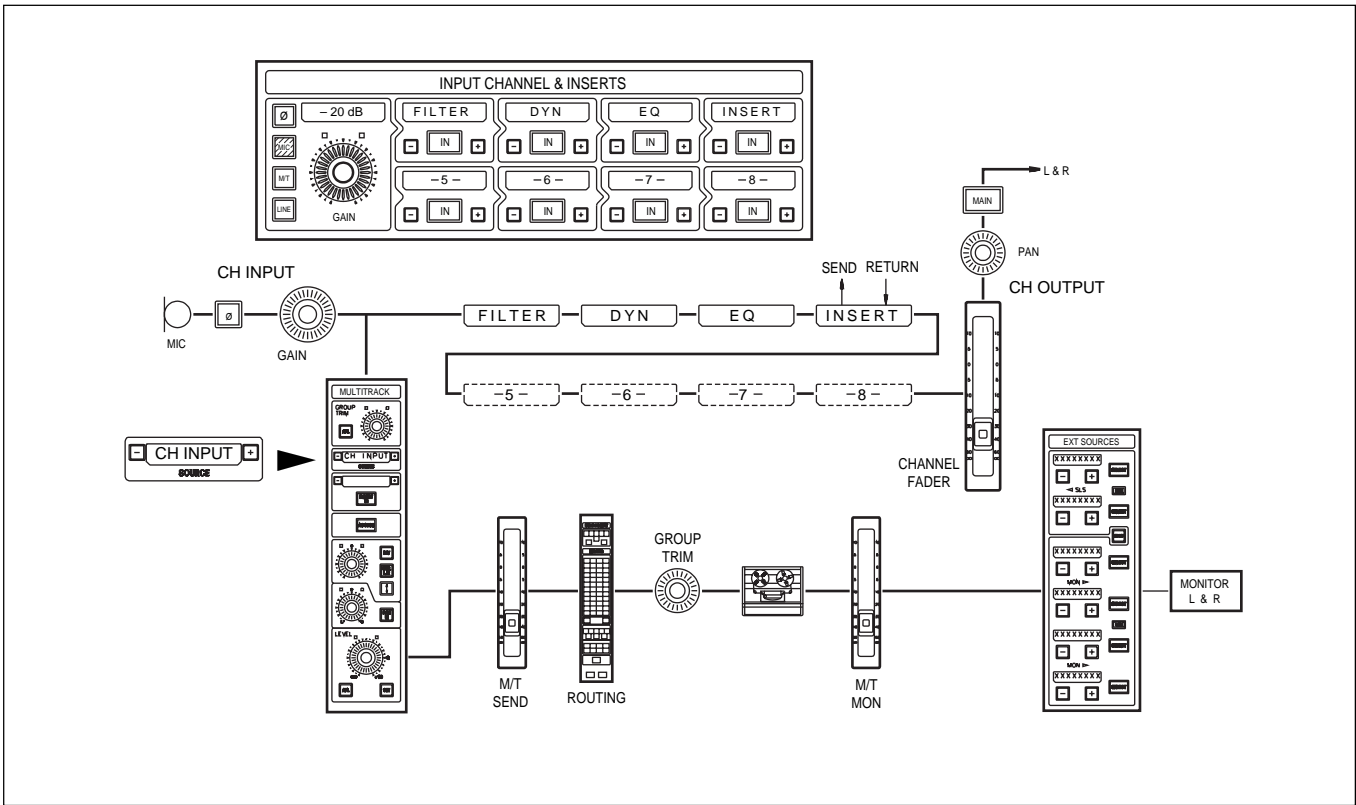

Broadcast Mode – Channel Input source

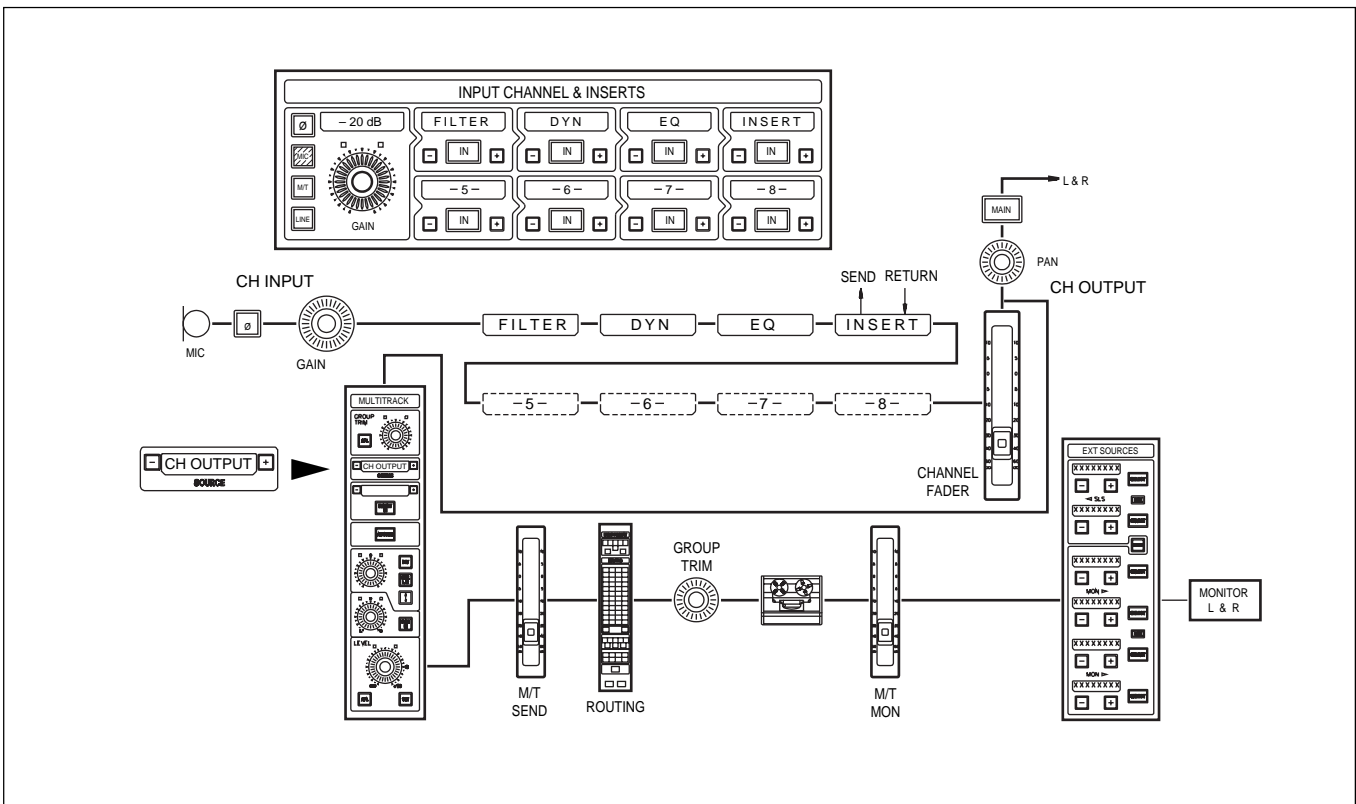

Broadcast Mode – Channel Output source

### Monitoring the multitrack

To listen to the stereo Multitrack Send Monitor Bus, select M/T MON at the Ext. Source section of the Monitor panel in the centre section. This is a dedicated internal monitor bus designed specifically for use when making a parallel multitrack recording, alongside a stereo mix.

To set up a monitor balance, select **M/T MON** at the Select To Faders panel and use the channels section faders.

The default monitor source is the Main Output bus. Selecting M/T MON at the Ext. Source section allows direct comparison of the Multitrack Monitor mix and the Main Output bus mix.

**Note:**

*The {SEND} and {RET}(urn) Ready/Monitor switching on the control surface functions in the normal manner in Broadcast Mode.*

# 4-10 Channel Metering

The Channel Meter sources are set automatically according to the functions in use in the channels.

## 4-10-1 Channel Meter Default

The fire-up default for the Channel Meters is pre fader as illustrated in the following diagram. This is denoted on the OXF-R3 by the red 'C' legend at the top of the Channel Meters.

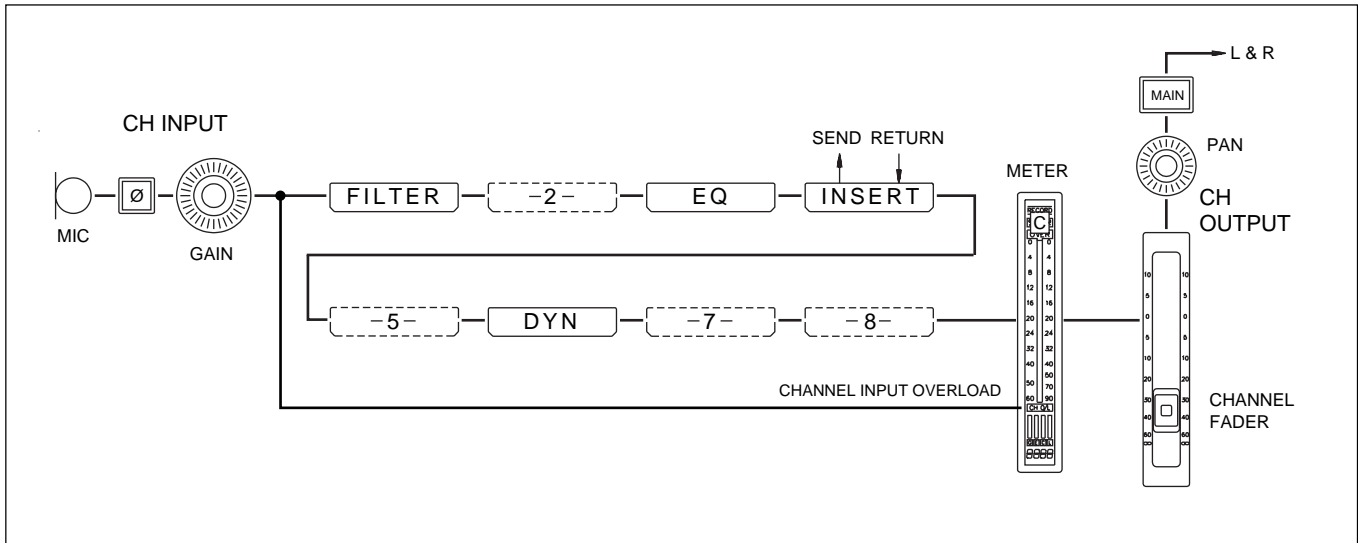

Channel metering – Default

## 4-10-2 Channel Meters to Input

Selecting **MTRs TO INPUT**, at the METERS selector in the centre section monitor panel causes the channel meters to monitor the audio level in the digital domain, post the channel input gain control stage.

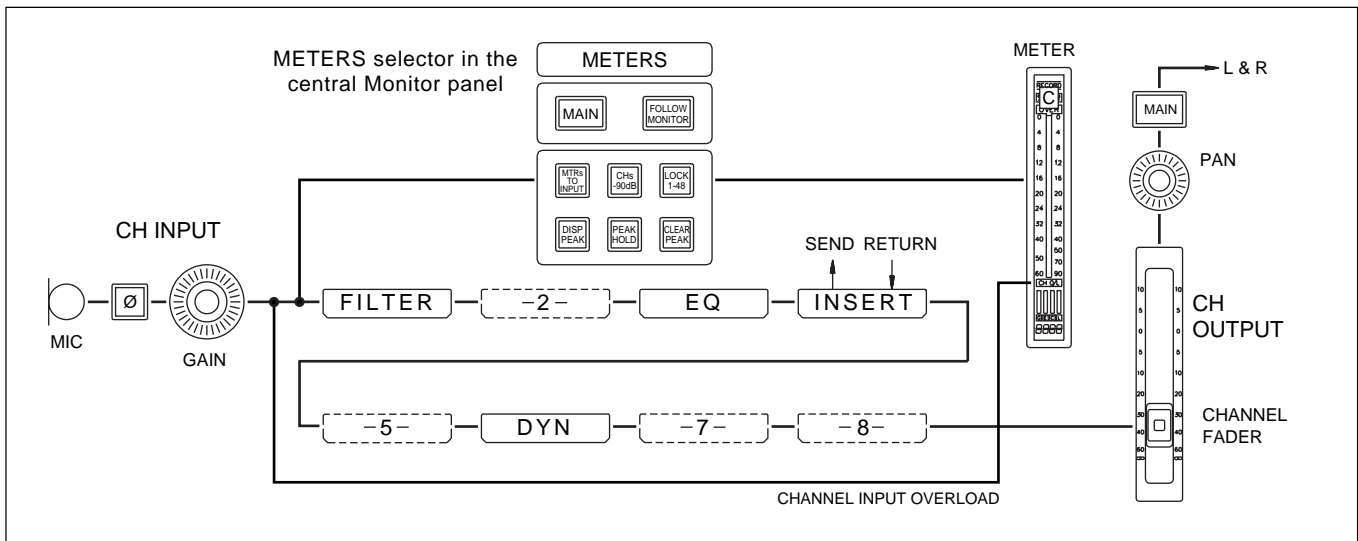

Channel metering – Channel Meters to Input

## 4-10 Channel Metering

### 4-10-3 Send Monitor

Selecting the **SEND** button at the channel record remotes causes the Meter to take its source from signal being sent to tape, indicated by the yellow 'S' legend at the top of the Channel Meters.

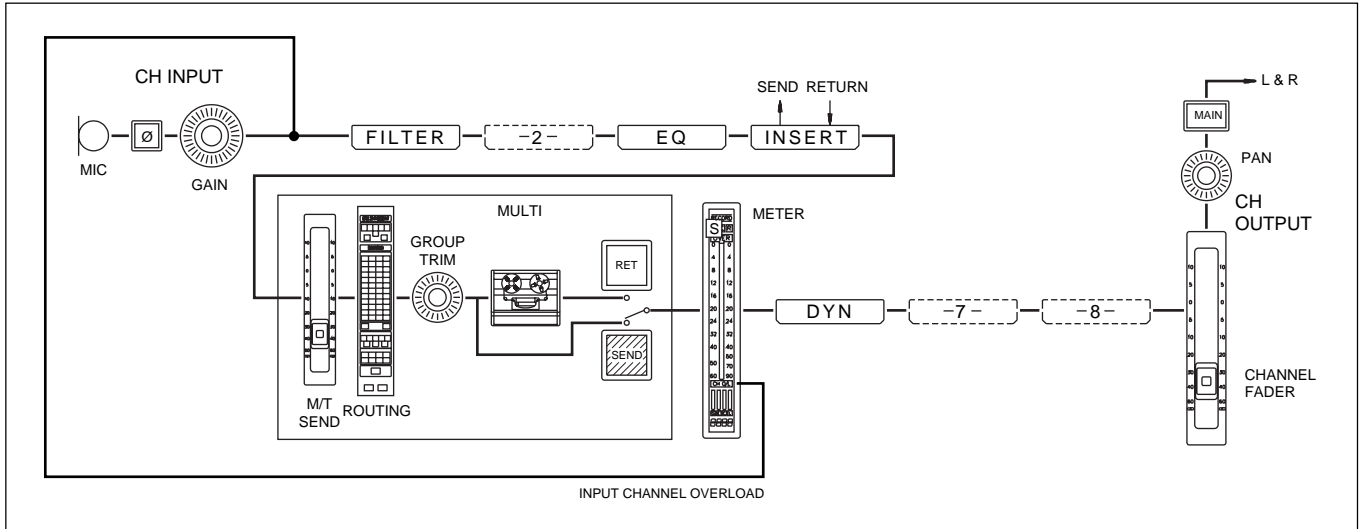

Channel metering – Send Monitor

### 4-10-4 Return Monitor

Selecting the **RET** button at the record remotes selects the tape return as the source, indicated by the green 'R' legend at the top of the Channel Meters. In Record, the meter is automatically switched to monitor SEND.

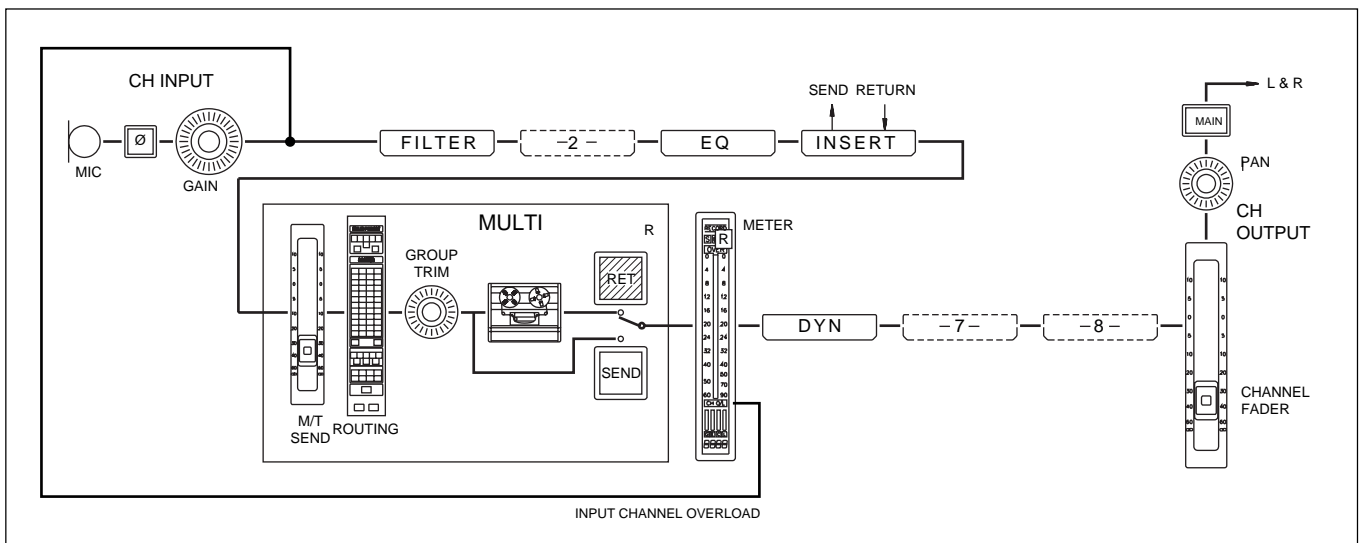

Channel metering – Return Monitor

**Note:**

If both **SEND** and **RET** are selected, the **SEND** monitor signal takes priority.



## 4-10-5 MULTI in Channel Path

If MULTI is selected in one of the 8 windows but neither **SEND** nor **RET** push-button is selected, the Meter is fed pre fader. The input signal source is overridden by the multitrack return signal.

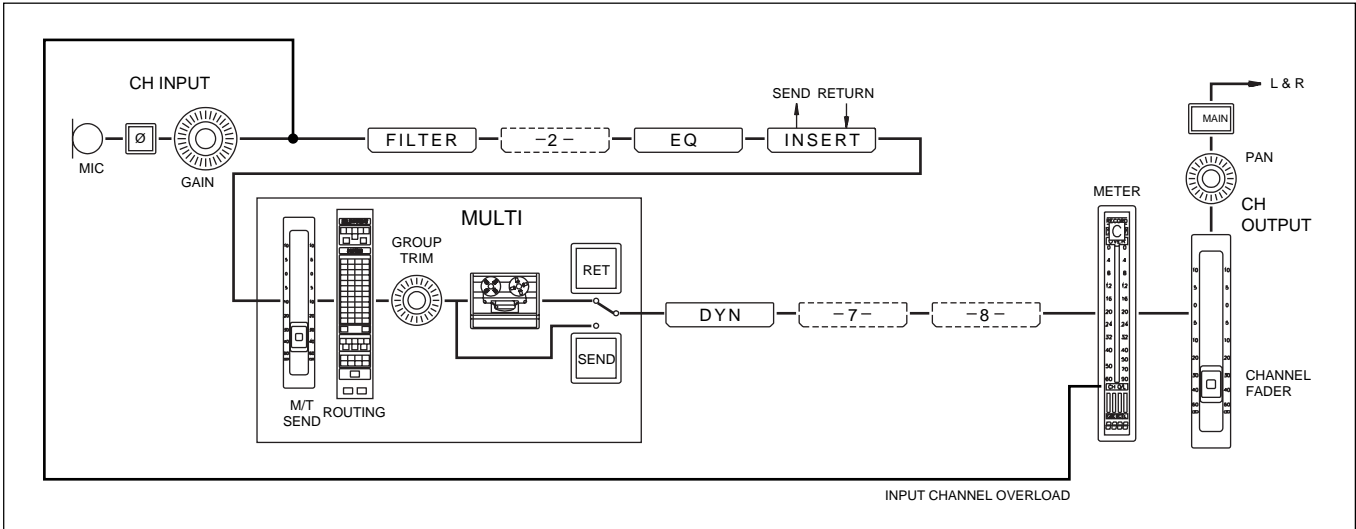

Channel metering – MULTI in channel path, but Send or Return push-buttons are not selected

# 4-11 Dynamics Side-Chain Linking

## 4-11-1 Dynamics Side-Chain Link Right

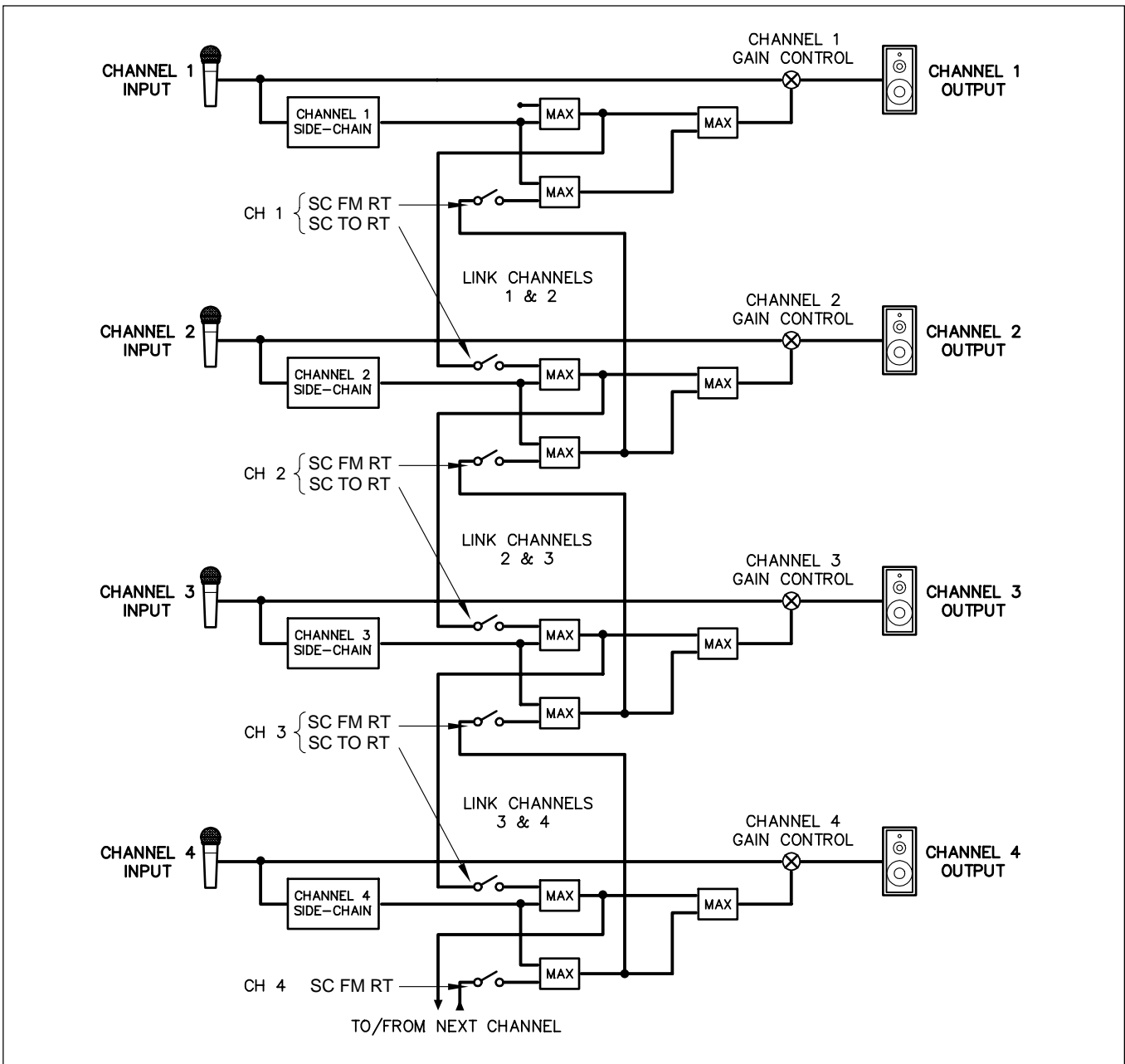

Block schematic to illustrate Dynamics Side-Chain Linking to the next channel to the right

### Dynamics Side-Chain Link Right in general

This function allows the Dynamics section in the next channel to the right to be controlled by the Side-Chain of the currently accessed channel and vice versa. The linking can be cascaded over any number of channels to form a group, and may be linked through channels where the Dynamics sections are not active. No matter how many channels are cascaded, the one with the largest Side-Chain Control Signal will accurately control all the rest. It is often useful to Copy or Link the front panel controls of the channels using the Dynamics Side-Chain Link Right function (see 7-6-8 in Chapter 7)

### Dynamics Side-Chain Link Right set-up procedure

The buttons for this operation are located in the Free Assign Area & Dynamics panel. They are the assignable buttons just left of centre in the upper section of this panel. Their function is indicated by individual 8 character displays, one positioned to the left of each button. (see Chapter 6, section 6-2-6)

There are two 8 character displays which relate to this function, and the fire-up default is **LOCAL** in both. The upper display indicates the destination for the Side-Chain Signal generated by the current channel. The lower display indicates the source for the Side-Chain Signal for the current channel.

### Set-up procedure

- 1** The middle button sets where the Side-Chain Control Signal is sent. The default is **LOCAL** i.e. to its own channel. Step through the options with this button and set it at **SC TO RT**. This setting sends its Side-Chain Control Signal to the next channel to the right.
- 2** The lower button sets where the Side-Chain Control Signal is taken from. The default is **LOCAL** i.e. from its own channel. Step through the options with this button and set it at **SC FM RT**. With this setting, the current channel takes its Side-Chain Control Signal from the next channel to the right.

A set-up using 1 and 2 above creates a stereo dynamics section.

- 3** Repeat 1 and 2 above on further channels as desired.

## 4-11 Dynamics Side-Chain Linking

### 4-11-2 Dynamics Side-Chain Busses 1-4

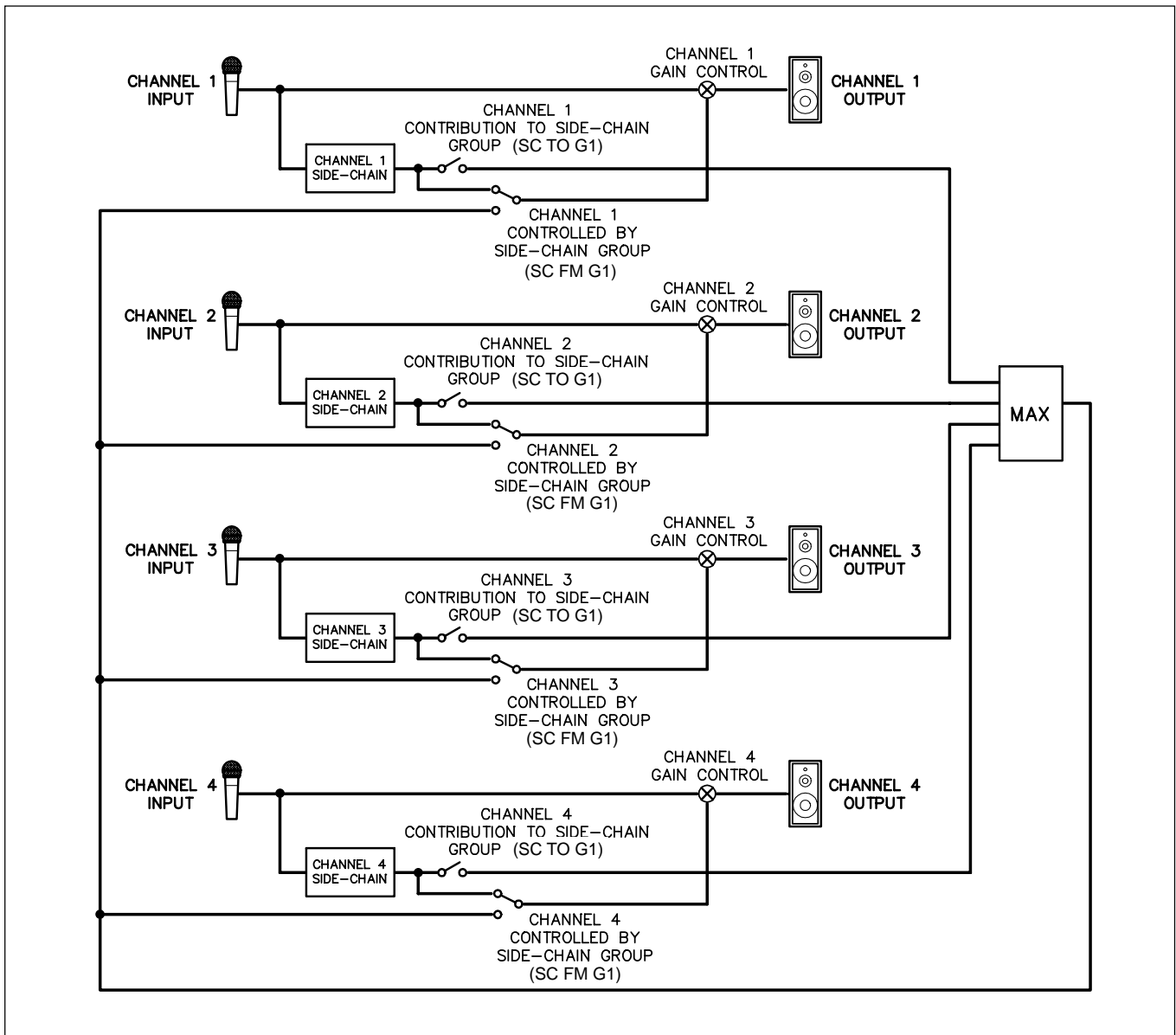

Block schematic to illustrate the switching for Dynamics Side-Chain Bus 1

#### Dynamics Side-Chain Busses 1-4 in general

This function allows any channel to feed its Side-Chain Control Signal to any one of four Side-Chain Busses. Any channel can also take its Side-Chain Control Signal from any one of the four Side-Chain Busses. There is no limit to the number of channels accessing the Side-Chain Busses. For a given set of channels linked to an individual Side-Chain Bus, the channel generating the largest Control Signal will accurately control the rest of the channels

### Dynamics Side-Chain Bus operation

The buttons for this operation are located in the Free Assign Area & Dynamics panel. They are the assignable buttons just left of centre in the upper section of this panel. Their function is indicated by individual 8 character displays, one positioned to the left of each button. (see Chapter 6, section 6-2-6)

There are two 8 character displays which relate to this function, and the fire-up default is **LOCAL** in both. The upper display indicates the destination for the Side-Chain Signal generated by the current channel. The lower display indicates the source for the Side-Chain Signal for the current channel.

For example, a display indicating **SC TO G1** means that the Side-Chain Signal is being fed to Side-Chain Bus 1. **SC TO G2** means that the Side-Chain Signal is being fed to Side-Chain Bus 2. **SC FM G4** means that the Side-Chain Signal is being received from Side-Chain Bus 4.

### Dynamics Side-Chain Bus set-up procedure

The following example will send the Side-Chain Signal to Compressor Side-Chain Bus 1. It will also use Bus 1 as its Side-Chain Signal source. This allows:

- Control of itself.
- Control of any other channels using Side-Chain Bus 1 as their Side-Chain source.
- Control by any other channels sending their Side-Chain Signal to Side-Chain Bus 1.

- 1** The middle button sets where the Side-Chain Control Signal is sent. The default is **LOCAL** i.e. to its own channel. Step through the options with this button and set it at **S-C TO G1**. This setting sends its Side-Chain Control Signal to Side-Chain Bus 1.
- 2** The lower button sets where the Side-Chain Control Signal is taken from. The default is **LOCAL** i.e. from its own channel. Step through the options with this button and set it at **SC FM G1**. With this setting, the current channel takes its Side-Chain Control Signal from Side-Chain Bus 1.
- 3** Repeat 1 and 2 above on further channels as desired.

# 4-12 Mixing to the Main Output Bus

## Multi-Channel Main Output Bus in general

The Main Output Bus for the OXF-R3, which doubles as the M/T Monitor Bus, can be used for Stereo or Surround mix-down according to the set-up in the centre section. The set-up procedure is described later in this section.

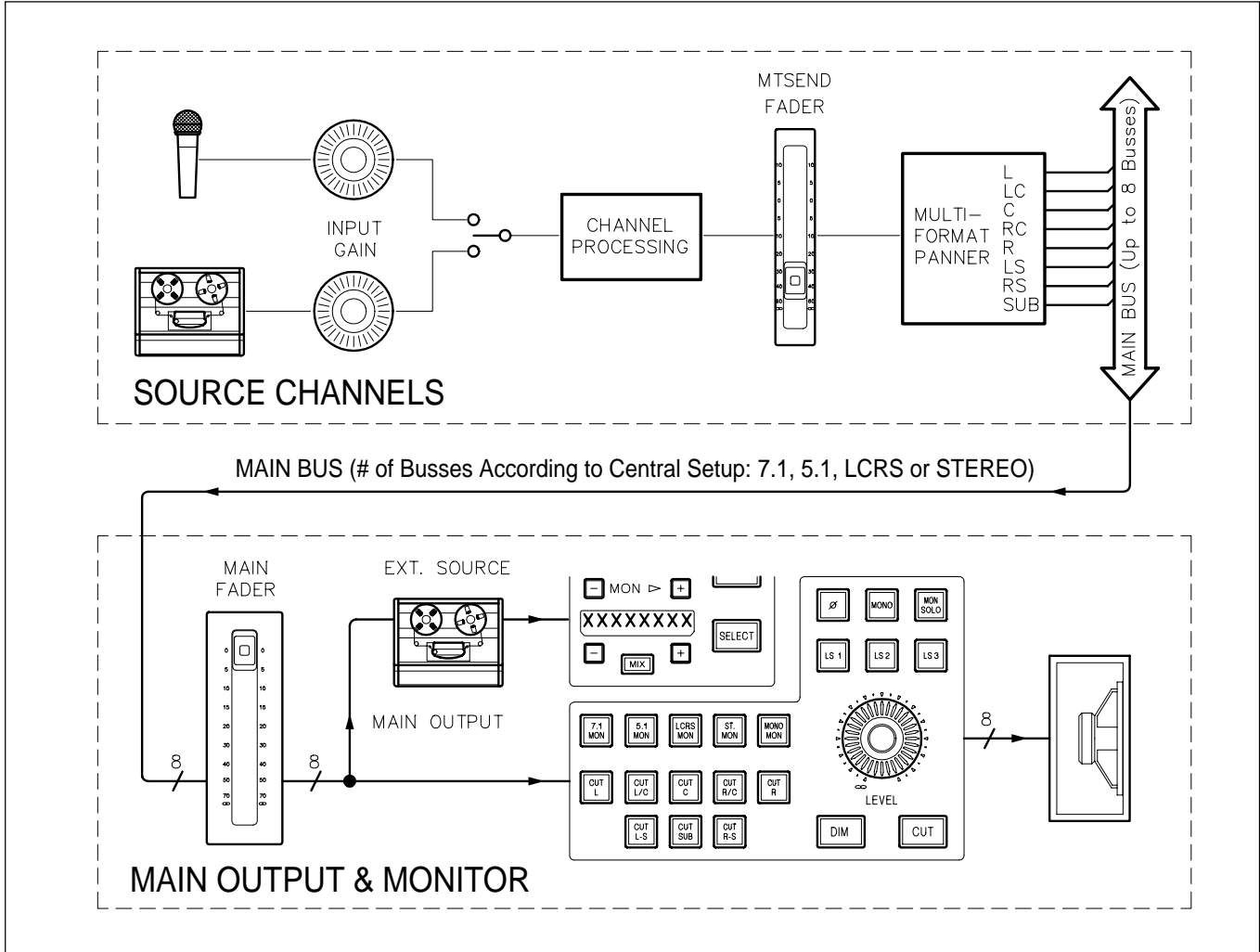

Simplified signal path illustrating the components for mixing to the Multi-Channel Main Output

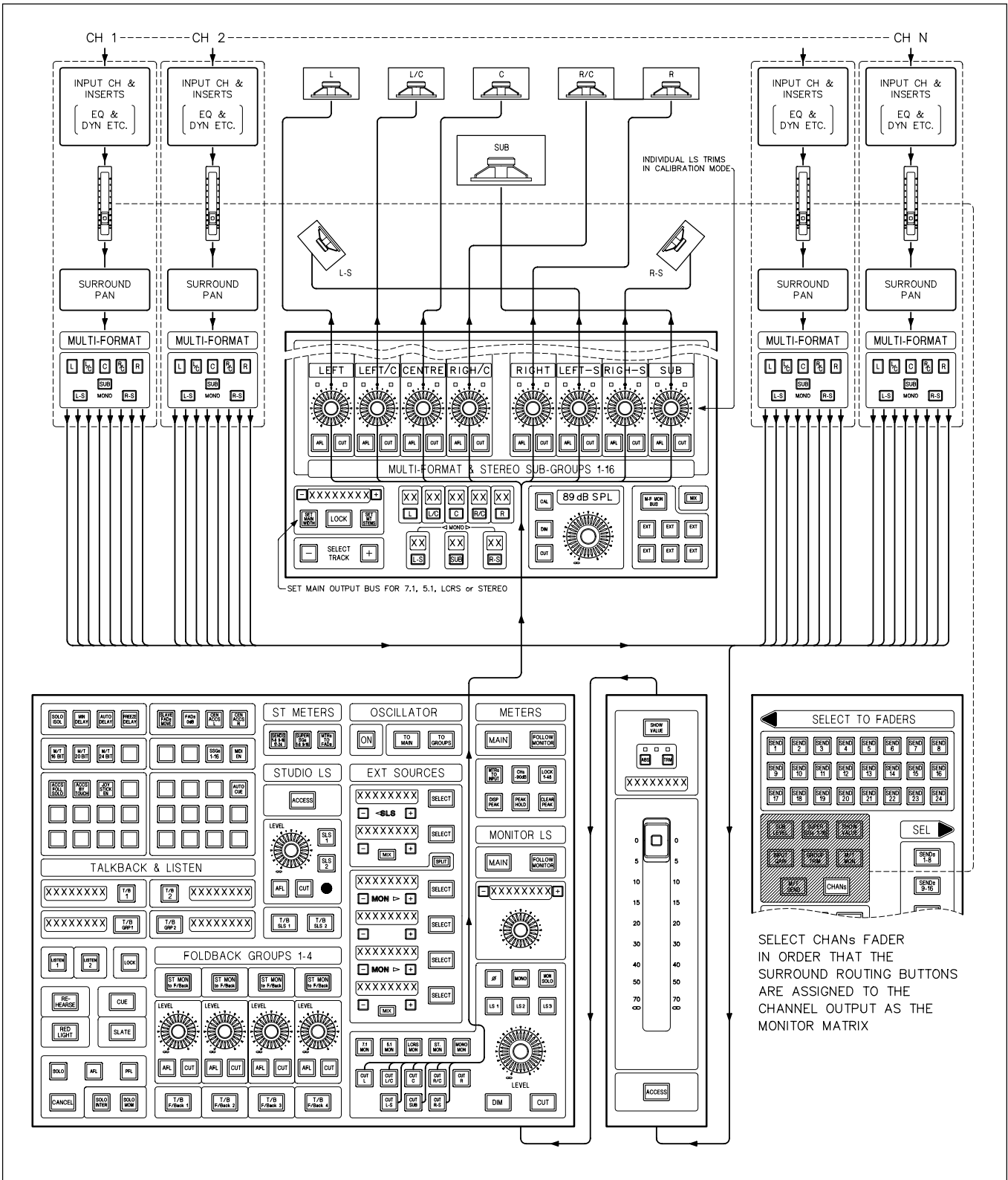

Block Schematic of Stereo and Surround Mix-Down illustrating interconnections of all components, including monitoring

## 4-12 Mixing to the Main Output Bus

### 4-12-1 Main Output Bus Set-up

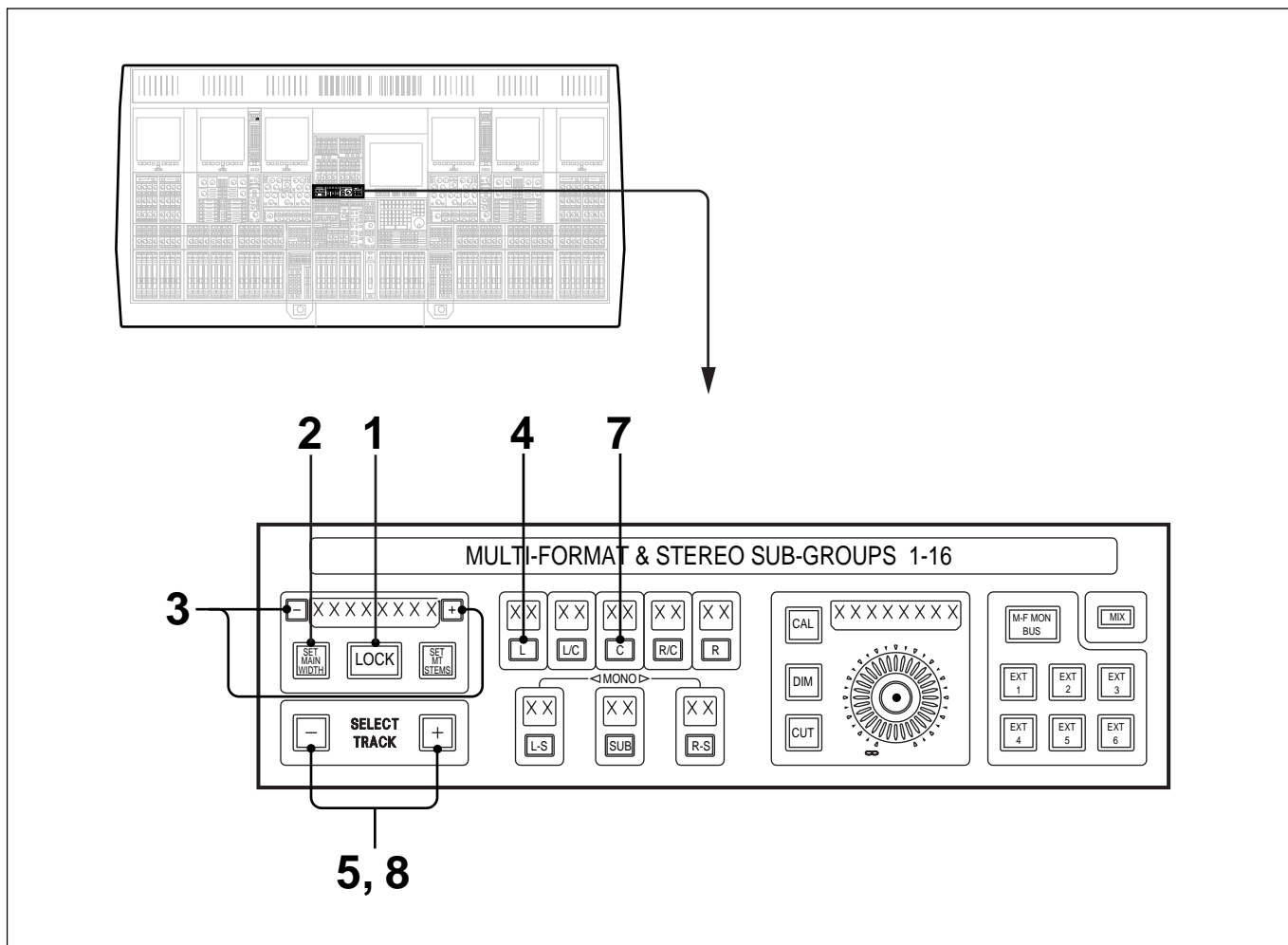

#### Master Section set-up functions

The 8 character dot display to the left of this panel can display the format for the Main Output Bus and that of M/T Stems.

If the **SET MAIN WIDTH** button is lit, the format for the Main Output Bus is displayed: STEREO, LCRS, 5.1 or 7.1. The current format for the Main Output Bus is also displayed in the 8 character display above the central Master fader.

If the **SET MT STEMS** button is lit, the format for the M/T Bus is displayed: STEREO, LCRS, 5.1 or 7.1.

- 1 The **LOCK** push-button is normally lit, indicating that the set-up is locked. Press to unlock indicated by the light going off. This button will time out back to lock status 10 seconds after the last button push.

#### Note

A Config. Set-up option enables the **LOCK** button as a level of security, i.e. it must be unlocked to allow bus assignment set-up.



- 2 While the system is unlocked, press the **SET MAIN WIDTH** button to check the Main Bus width matches requirements, if not already displayed.
- 3 To change it, while the system is unlocked, use the **+** or **-** button to step through the formats: STEREO, LCRS, 5.1 and 7.1 until the desired format is displayed by the 8 character dot display above the **LOCK** push-button. It will also be displayed above the central Master Fader.

### Main Bus to Multitrack

As well as feeding the Main Output to external destinations, the system allows the Main Bus signal to be laid back onto the multitrack if required. But before this can be done, the tracks to be used for this purpose must first be assigned. Continue the set-up as follows:

- 4 The system must be unlocked to assign the multitrack busses which will be fed from the Main Output Bus.

To assign the L channel for example, press and hold the **L** button, and it lights.

- 5 Step through the multitrack busses using the **SELECT TRACK** **+** and **-** buttons until the desired bus number is displayed in the 2 character display above the **L** button. This track has then been assigned for the L channel of the Main Output Bus.
- 6 Repeat steps 4 and 5 for the other destination busses.

### To Clear any Multitrack Bus Destinations

As an example, to clear the bus set up as the C channel:

- 7 Press and hold the **C** button and it lights.
- 8 Press the **SELECT TRACK** **+** and **-** buttons simultaneously to clear the bus assignment for the C channel.

## 4-12 Mixing to the Main Output Bus

### 4-12-2 Channel Signal to the Main Output

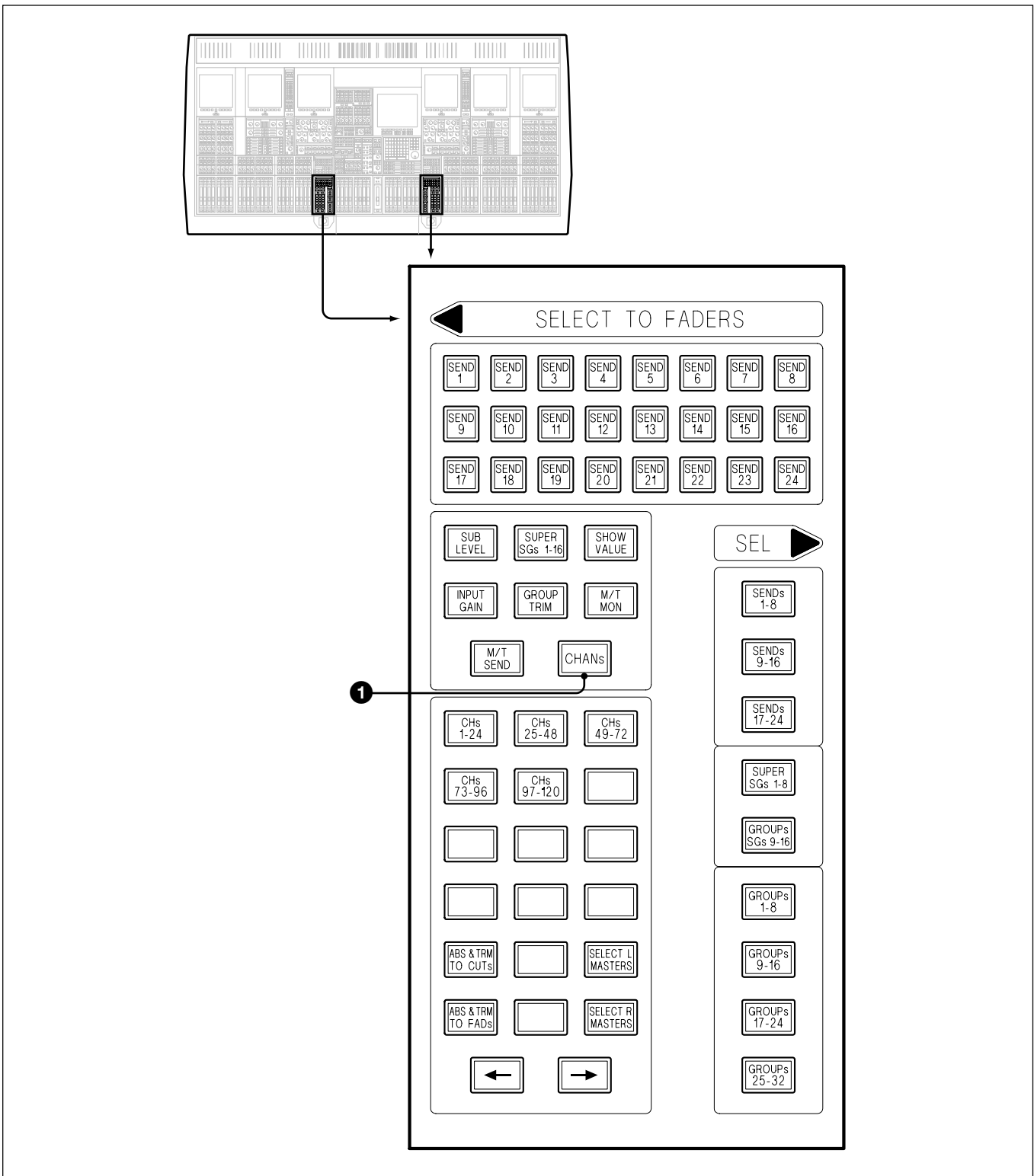

#### ❶ CHANS Push-Button

Sets the faders in the channels sections to control the level of the Channel Outputs to the Main Output Bus. Make sure this button is selected.

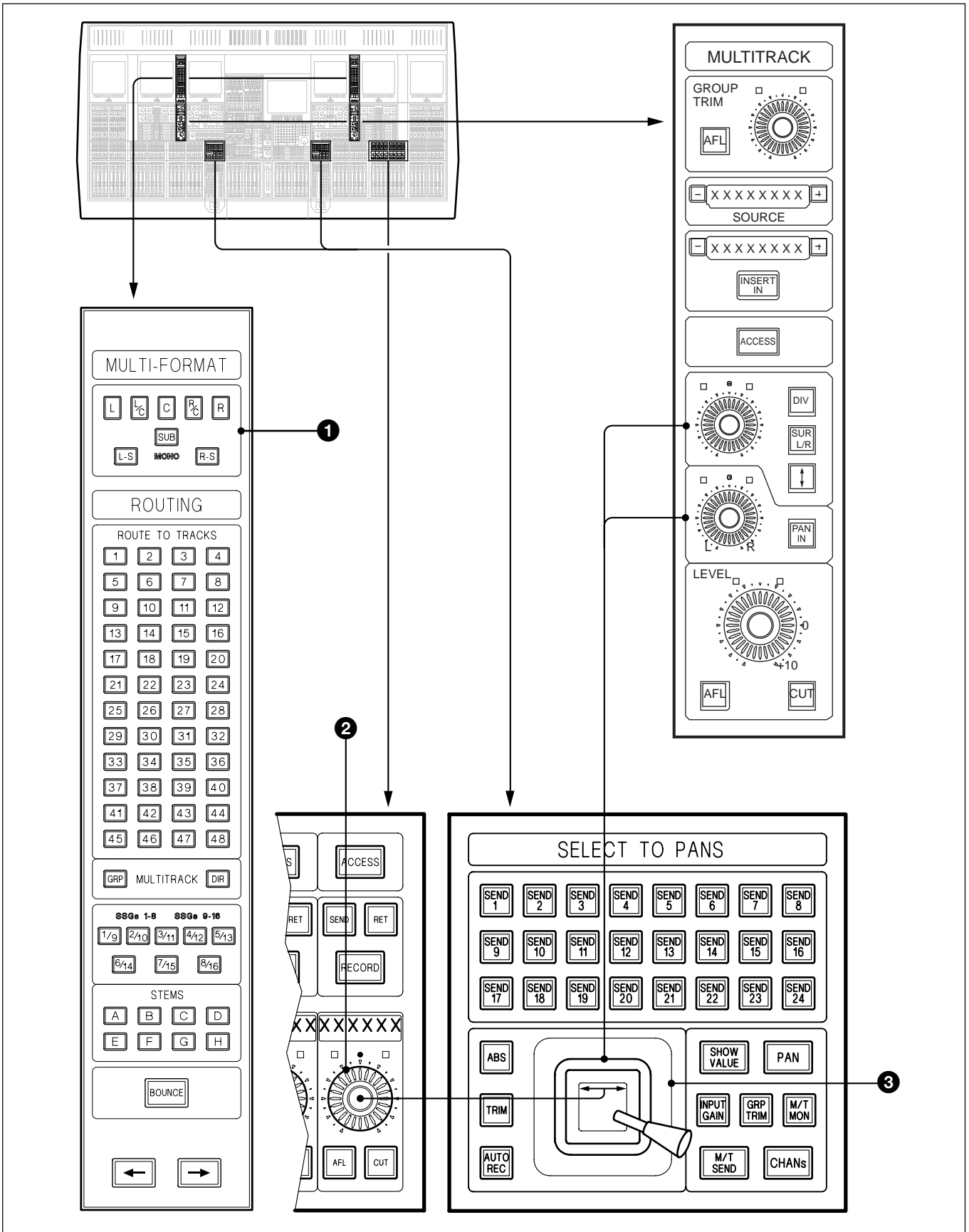

Stereo / Routing routing and panning when mixing to the Main Output

### Routing, Stereo and Surround Panning in general

The controls used for routing and panning of signals may be assigned to a number of functions including the Channel Output, Multitrack Send and the SSGs (Super Send Groups). The following describes their use when assigned to the Channel Output, by selecting **[CHANS]** on the SELECT TO FADERS panel.

#### ❶ MULTI-FORMAT Routing Push-Buttons

The surround routing buttons are laid out in the form of a surround sound LS layout. Only those consistent with the format selected in the master section will be operable. The fire-up default is Stereo indicated by the L and R buttons being lit.

#### ❷ Definable Knobs

Pan is the fire-up default for the Definable Knobs, indicated by **[PAN]** being lit on the SELECT TO PANS panel. This allows control on a channel by channel basis for L/R pan settings for Stereo and L/C/R for surround modes.

#### ❸ Touch Sensitive Motorised Joystick Panner

Any signal routed to two or more busses can be panned using one of the joysticks, one at each side of the control surface. The joysticks are assigned according to channel **[ACCESS]** buttons. They work in tandem with the Pan knobs on the MULTITRACK panel and the Pan function for the Definable Knobs. All three controls track each other. If one is put into automation write, the others will follow automatically. The joystick will move according to automated moves and the **[AUTO REC]** push-button lights when the joystick is touched.

#### Note

*The Surround Routing buttons in the MULTI-FORMAT section of the Routing panel and panners will always operate on whatever function is assigned to the Faders, via the SELECT TO FADERS panel.*

# 4-13 Multi-Stem Set-up

## MULTI-STEM in general

Recording a stem works in much the same way as recording a mono or stereo signal to multitrack. The differences are the surround sound panning instead of stereo and that the Main Output Bus, which is used as the monitor path, must be set to a suitable surround format.

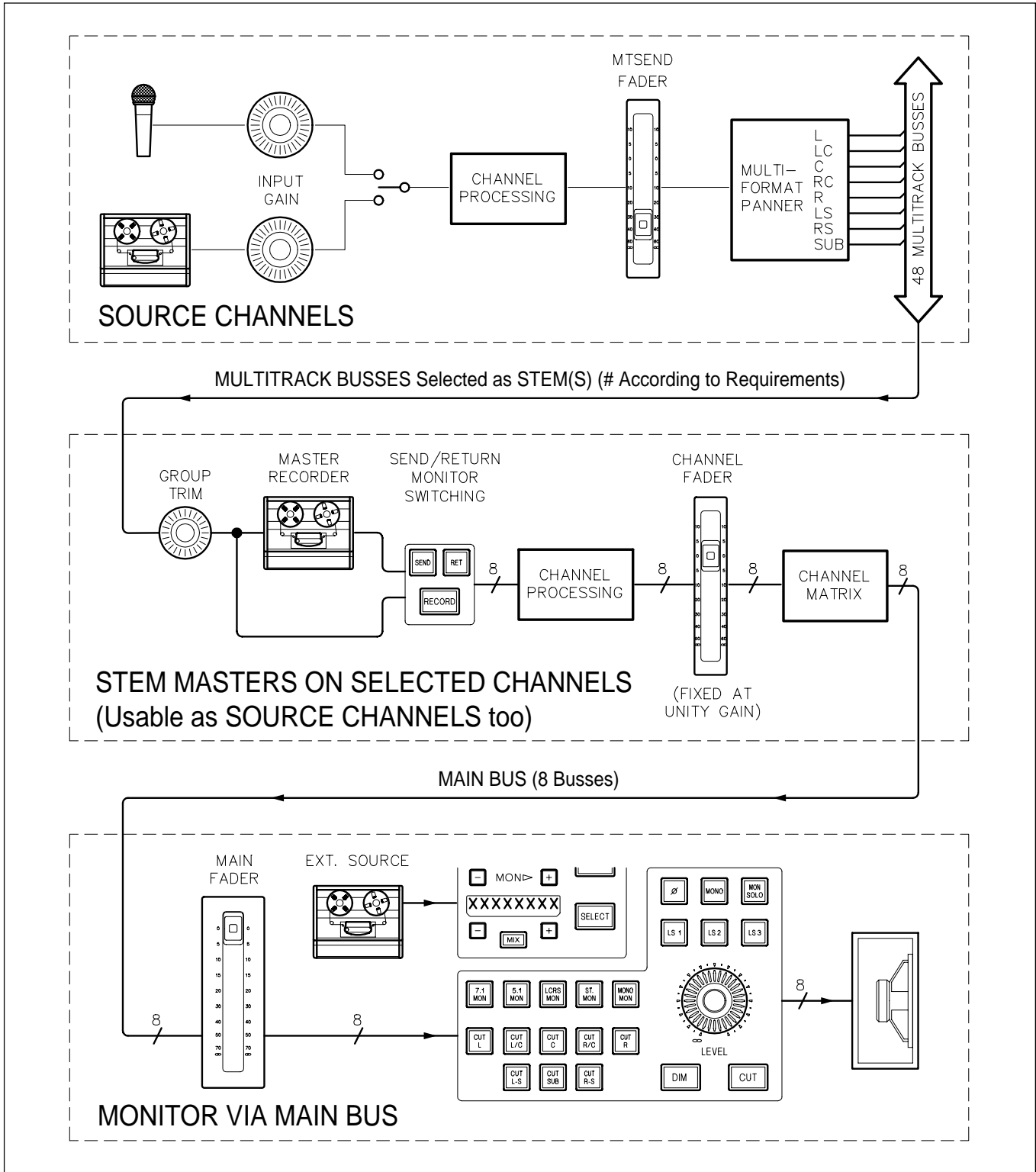

Simplified signal path illustrating the components for mixing to the Multi-Channel Main Output

# 4-13 Multi-Stem Set-up

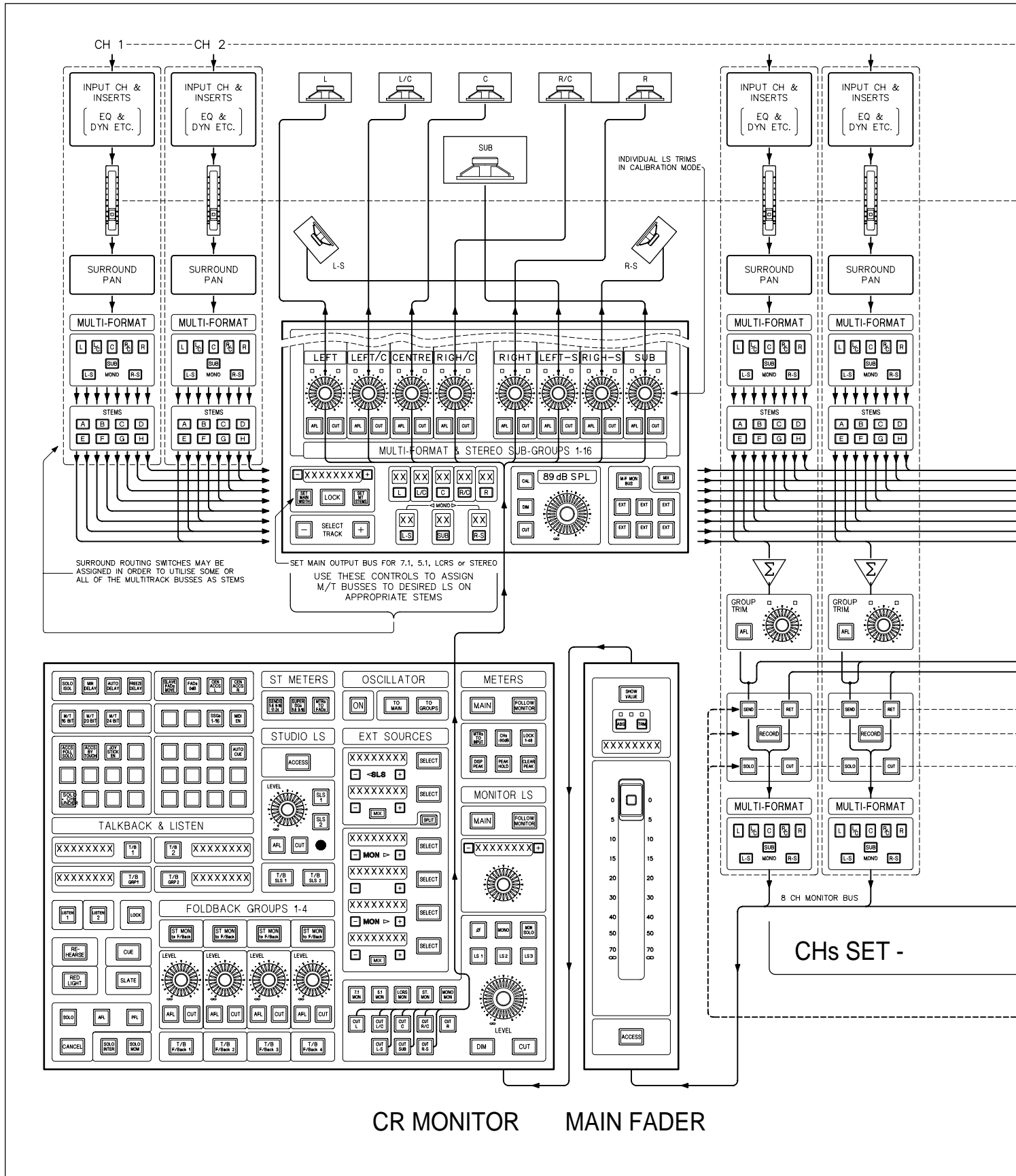

Block Schematic of Multi-Stem Scheme illustrating interconnections of all components, including monitoring

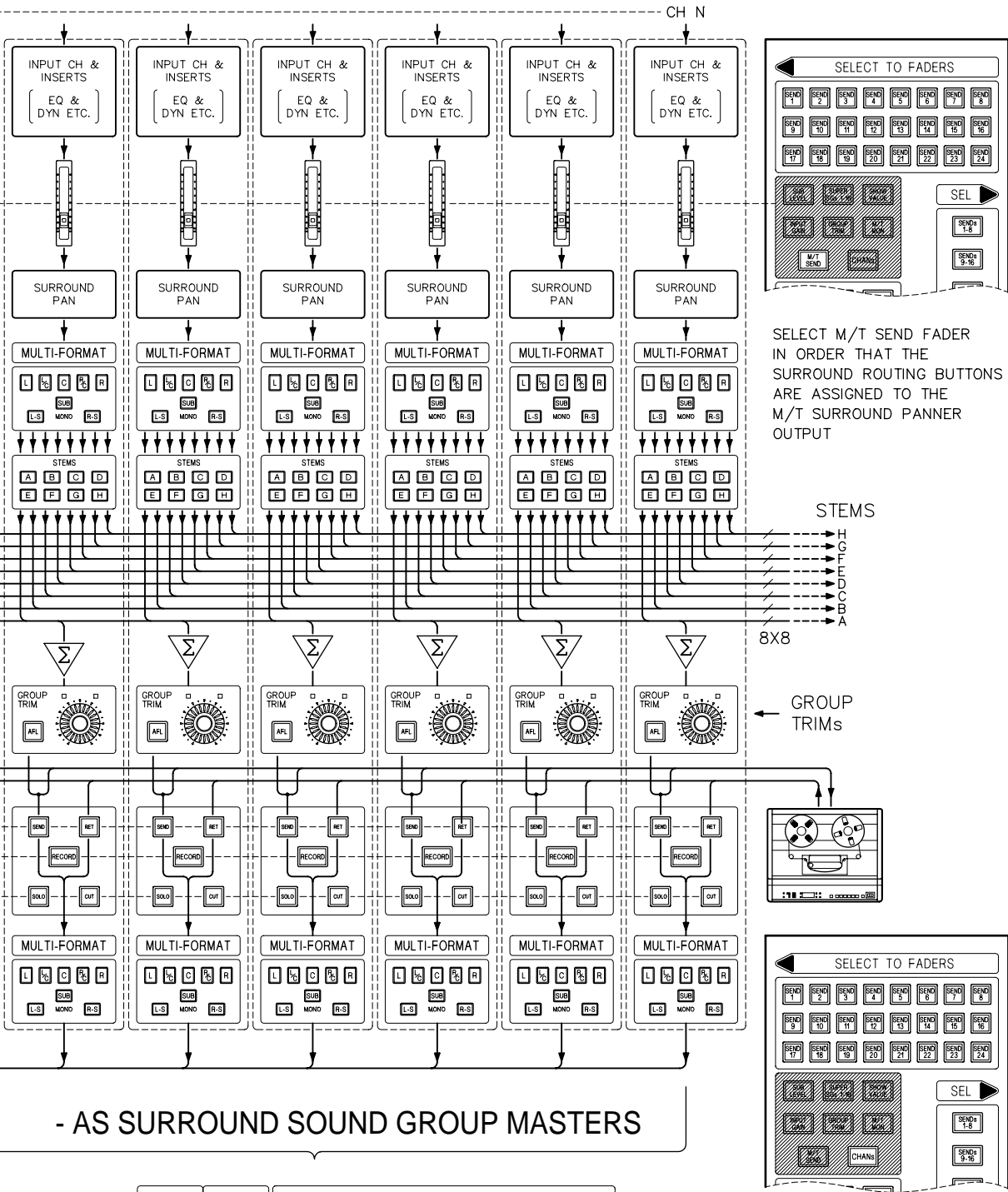

- AS SURROUND SOUND GROUP MASTERS



CHs SET UP AS GROUP MASTERS MAY BE ASSIGNED TO A REMOTE SET VIA GUI SETUP & OPERATED AS AN INDIVIDUAL MACHINE OR PART OF A VIRTUAL MACHINE. THIS ALLOWS GROUPED SOLOS, CUTS, READYs & RECORD FUNCTIONS. ALL OF THESE FUNCTIONS CAN BE CONTROLLED EXTERNALLY VIA GPI

SELECT M/T SEND FADER IN ORDER THAT THE SURROUND ROUTING BUTTONS ARE ASSIGNED TO THE M/T SURROUND PANNER OUTPUT

STEMS  
H  
D  
C  
B  
A

GROUP TRIMS

SELECT CHANS FADER IN ORDER THAT THE SURROUND ROUTING BUTTONS ARE ASSIGNED TO THE CHANNEL OUTPUT AS THE MONITOR MATRIX

## 4-13 Multi-Stem Set-up

### 4-13-1 Multi-Stem Set-up Procedure

The Main Output Bus for the OXF-R3, which doubles as the M/T Monitor Bus, has two basic modes of operation, Stereo or Surround. For Stem or Multi-Stem operation the Main Output Bus must be set to a Surround mode. Then M/T Busses can be assigned to stems which are configured automatically to use the Main Output Bus for monitoring purposes.

**Note**

*The width of stems, e.g. the number of busses in stems, is limited to a maximum width no greater than the width of the Main Output Bus.*

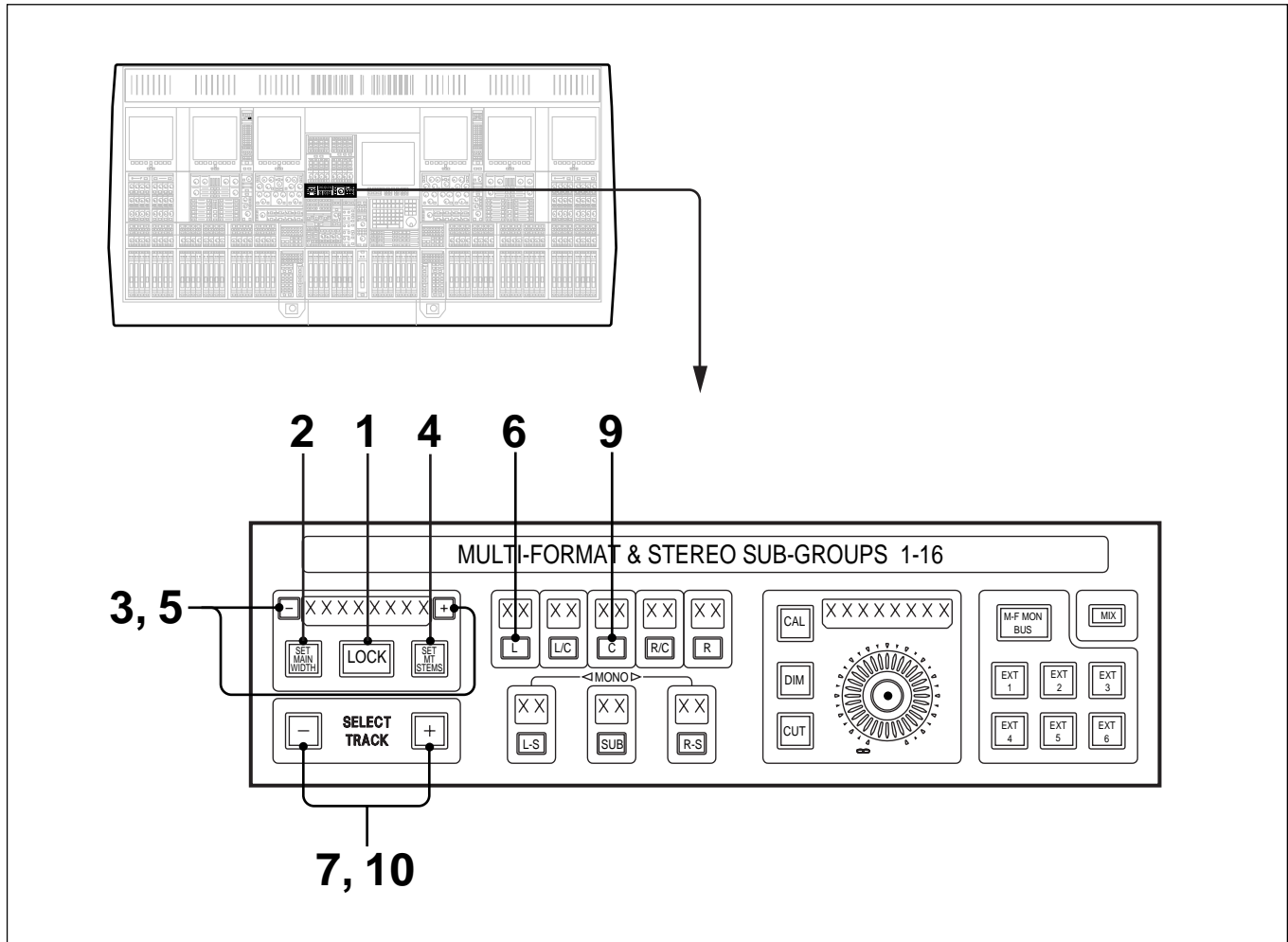

#### Master Section set-up functions

The 8 character dot display to the left of this panel can display the format for the Main Output Bus and that of M/T Stems.

If the **SET MAIN WIDTH** button is lit, the format for the Main Output Bus is displayed: STEREO, LCRS, 5.1 or 7.1.

If the **SET MT STEMS** button is lit, the format for the M/T Bus is displayed: STEREO, LCRS, 5.1 or 7.1. A stem reference, one of A–H, will also be included if surround is in operation.



- 1 The **LOCK** push-button is normally lit, indicating that the set-up is locked. Press to unlock, indicated by the light going off. This button will time out back to lock status 10 seconds after the last button press.

**Note**

*A Config. Set-up option enables the **LOCK** button as a level of security, i.e. it must be unlocked to allow bus assignment set-up.*

- 2 While the system is unlocked, press the **SET MAIN WIDTH** button to check that the Main Bus width matches requirements if not already displayed.
- 3 If it does not, while the system is unlocked, use the **+** or **-** button to step through the formats: STEREO, LCRS, 5.1 and 7.1 until the desired format is displayed by the 8 character display above the **LOCK** push-button.
- 4 While the system is unlocked, press the **SET MT STEMS** button.
- 5 While the system is unlocked, use the **+** or **-** button to step through the formats: STEREO, LCRS, 5.1 and 7.1 until the desired type is displayed by the 8 character display above the **LOCK** push-button. An 'A' will be displayed initially to the right along with each format type, indicating that the settings displayed are for Stem A. If the system has already been in use, then other letters, B-H, may be displayed depending on how the system was left.

To select another Stem make sure that **LOCK** is lit, by pressing it or allowing it to 'time out', then use the **+** or **-** buttons either side of the 8 character display to step through stems A-H.

- 6 Multitrack busses are used as Multi-Stem master busses and must be selected as part of the set-up. The system must be unlocked to assign the multitrack busses.

To assign the L channel for example, press and hold the **L** button, and it lights.

- 7 Step through the multitrack busses using the **SELECT TRACK** **+** and **-** buttons until the desired bus number is displayed in the 2 character display above the **L** button. This track has then been assigned for the L channel for the Stem, one of A-H, indicated in the 8 character display. The track button in the ROUTE GUI will display a colour-coded outline, indicating that it has been assigned to a Stem.
- 8 Repeat steps 6 and 7 for the other busses required in the current Stem.

To assign busses for another Stem, make sure that **LOCK** is lit, by pressing it or allowing it to 'time out'. Then use the **+** or **-** buttons either side of the 8 character display to step through Stems A-H to the one which is required. Then repeat steps 6 and 7 for each of the busses required in that Stem.

### To Clear any Busses set up in Stems

As an example, to clear the bus set up as the C channel:

**9** Press and hold the  button and it lights.

**10** Press the SELECT TRACK  and  buttons simultaneously to clear the bus assignment for the C channel.



# 4-13 Multi-Stem Set-up

## 4-13-2 Multi-Stem Monitor Path

The channels which relate to the multitrack busses in stems need to be set up as the monitor path for each stem.

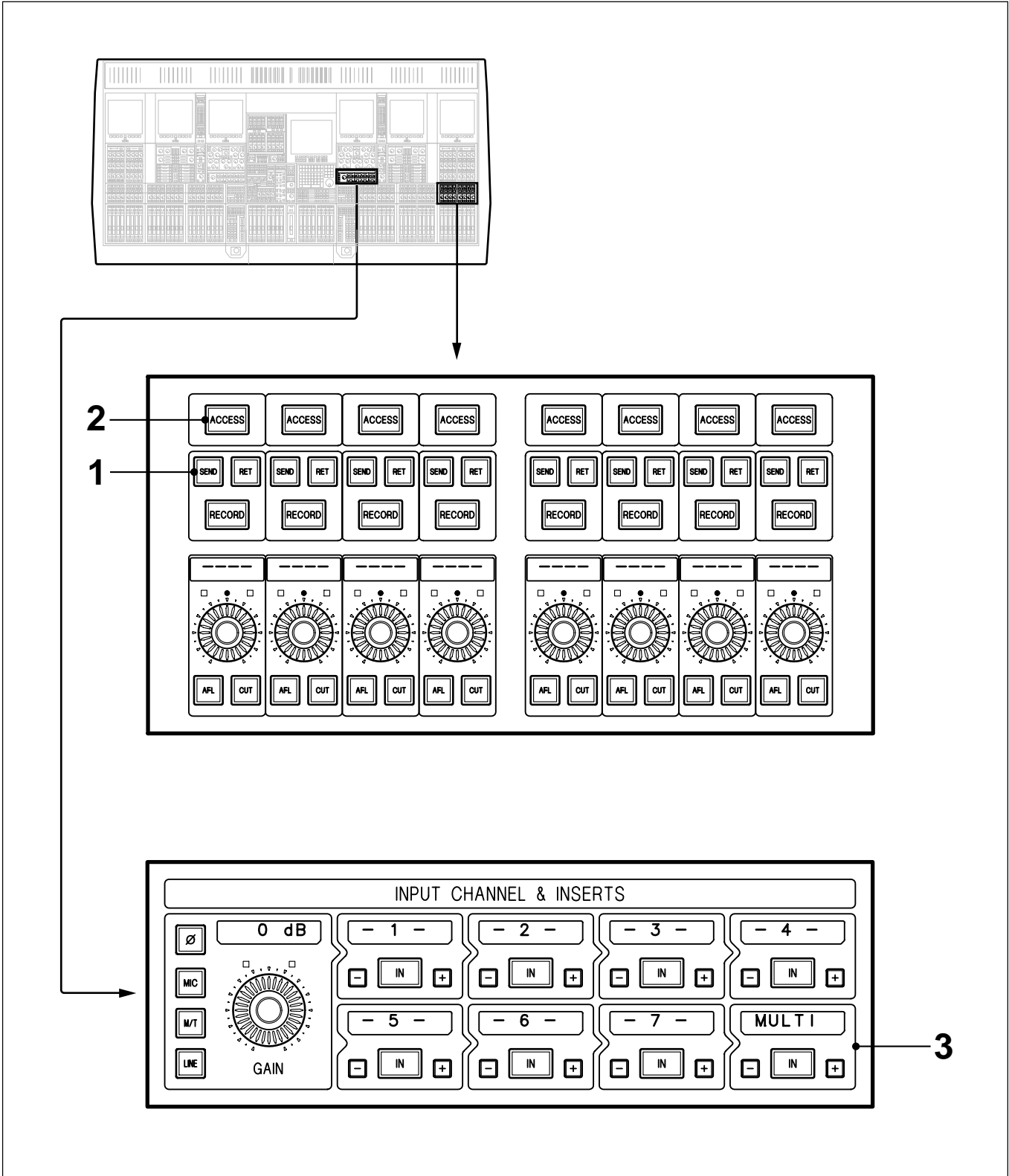

- 1 The **SEND** push-buttons relating to the Multi-Stem (multitrack) busses will be selected automatically during the master set-up.

**Note**

*In Multi-Format Mode the **SEND** and **RET** buttons for channels assigned as Stem masters inter-cancel.*

- 2 Select **ACCESS** for each Stem Master channel in turn.
- 3 Step through the options in box 8 for each stem channel on the Input Channel & Inserts panel until MULTI is shown in the 8 character display. Select its **IN** button. This will ensure that any processing inserted in boxes 1-7 will affect what is recorded via Stem Masters.

### Unity Gain Monitor Path using FADS 0dB Push-Button

The Main Output Bus is used in the monitor path via the Channel Faders which may be freely adjusted. In order to lock Channel Faders for Stem Master Channels at unity gain:

- 4 Make sure **CHANS** is selected at the SELECT TO FADERS panel.
- 5 Press the **FADS 0dB** in the central Monitor panel and it flashes on and off (refer to 6-3-2 for details of **FADS 0dB** operation).
- 6 Press **ACCESS** at the bottom of the fader for each of the Stem Masters. Their faders will move to the 0dB point and will spring back to unity, if moved and released. **ACCESS** buttons will light amber.
- 7 Press the **FADS 0dB** to resume normal operations and faders will spring back.

**Note**

*When used this way the **FADS 0dB** function will not be affected by the loading of Snapshots, in that the 0dB locked fader settings cannot be overwritten.*

### Unity Gain setting and Snapshots

To allow the unity gain settings for Stem Master Channel Faders to be overwritten with Snapshots, the procedure is modified slightly:

- 5 Press the **FADS 0dB** and it flashes on and off.
- 6 Press **ACCESS** at the bottom of the fader for each of the Stem Masters. Their faders will move to the 0dB point and will spring back to unity if moved and released. **ACCESS** buttons will light amber.
- 7 Press **ACCESS** buttons again to release them from the 0dB function. They are no longer lit. Do not touch faders in order that they remain at 0dB, they will not spring back to the unity gain setting automatically.
- 8 Press the **FADS 0dB** to resume normal operations but note that the faders will not spring back if moved.

# 4-13 Multi-Stem Set-up

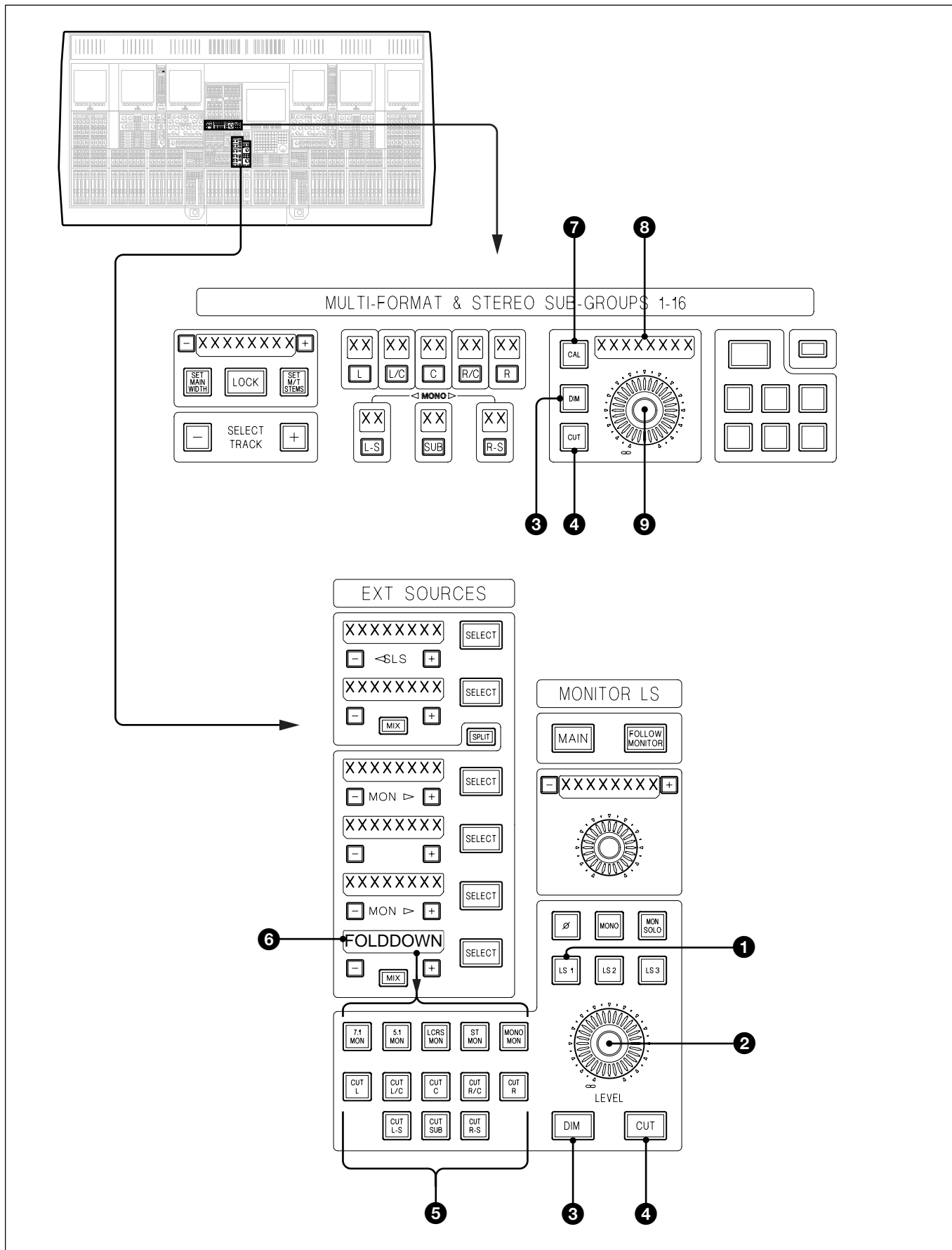

Once the Stem Masters have been set up on channels make sure the central Master Fader is set to maximum, 0dB. Then the monitor signal is available via the centre section controls as follows:

**Note**

*What follows is an overview of the Monitor functions. For detailed descriptions of individual functions, see Chapter 6.*

**1 LS1 Push-Button**

Selects the primary set of Monitor LS and is the fire-up default. Make sure the **[LS 1]** button is lit, or press it if not.

**2 CR Monitor Level**

Sets the level to the Control Room LS and operates in tandem with the Surround Level **9**, on the upper panel illustrated on the page opposite.

**3 DIM Push-Buttons**

Dims the CR Monitor LS according to the Dim setting, adjusted using the small definable knob situated above **2**.

**4 CUT Push-Buttons**

Cuts all the CR Monitor LS simultaneously.

**Note**

**[DIM]** and **[CUT]** are situated in both panel sections and work in tandem.

**5 CUT L – CUT R-S Push-Buttons**

Individual CR Monitor LS mutes.

**6 Surround Fold-Down Matrix**

The monitor signal fire-up default is the Main Output Bus. It is possible to listen to a folded down version of the Main Output Bus as follows:

- Select FOLDDOWN as the source in one of the EXT SOURCE windows using the **[+]** and **[-]** buttons either side of their 8 character dot display.
- Press to light the **[SELECT]** button to the right of that Source Selector.
- Select folded down versions of the Main Output Bus as desired and note that only sources of the same width or less than that of the Main Bus format are valid.

**7 CAL Push-Button**

Toggles between a fixed calibrated setting and the variable setting of the knob **9**.

**8 8 Character Dot Display**

Indicates the level in dB SPL, provided the system has been calibrated correctly. The Calibration Procedure is described in Appendix A-3.

**9 Level Knob**

Adjusts the levels for all LS simultaneously when **[CAL]** is not lit. To change the CAL setting, push, hold and adjust accordingly, then release.

## 4-13 Multi-Stem Set-up

### 4-13-3 Multi-Stem Source Channels

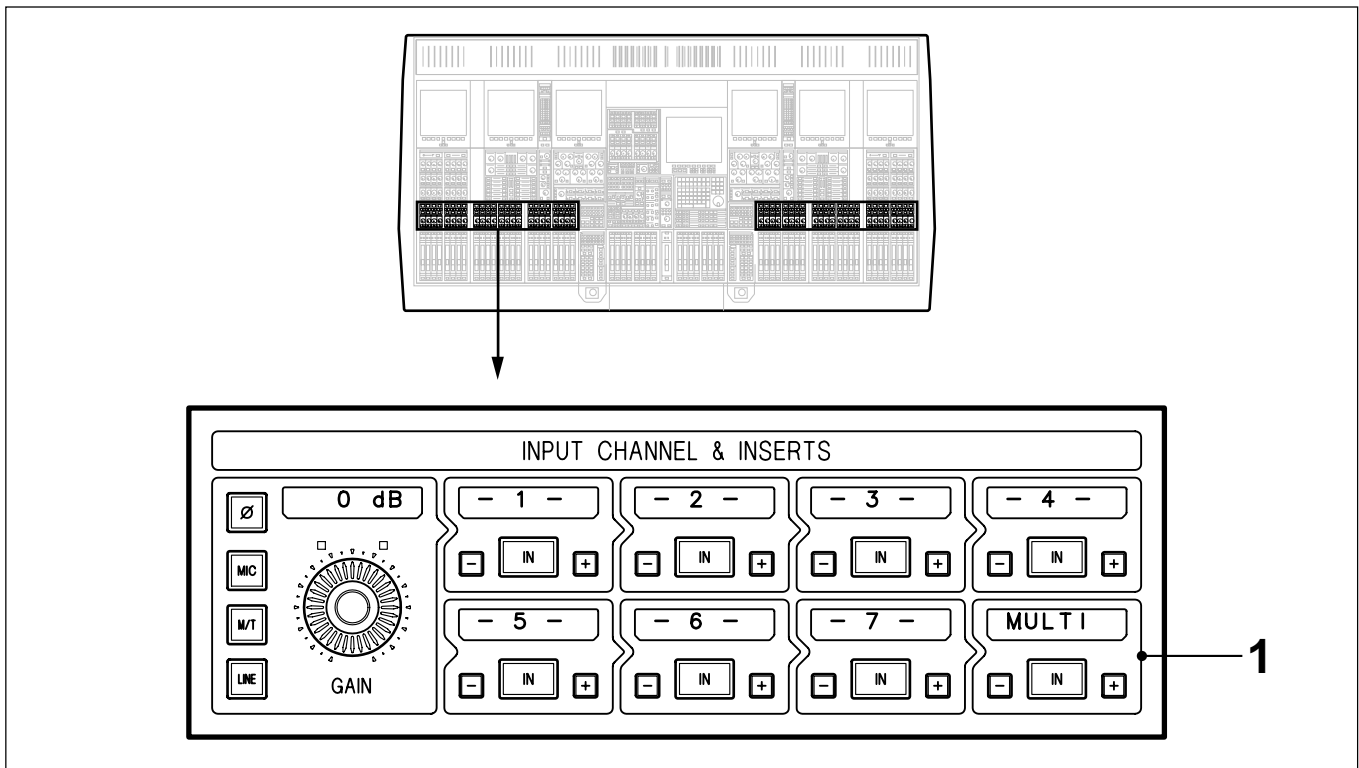

#### Setting up source channels

- 1 Select MULTI in box 8 for each source channel using the **+** and **-** buttons. Select its **IN** button. This set-up ensures that all processes assigned to boxes 1-7 affect the source signal sent to tape.

#### Note

*The channel paths for channels set up as Multi-Channel monitors sections may also be used as source channels.*



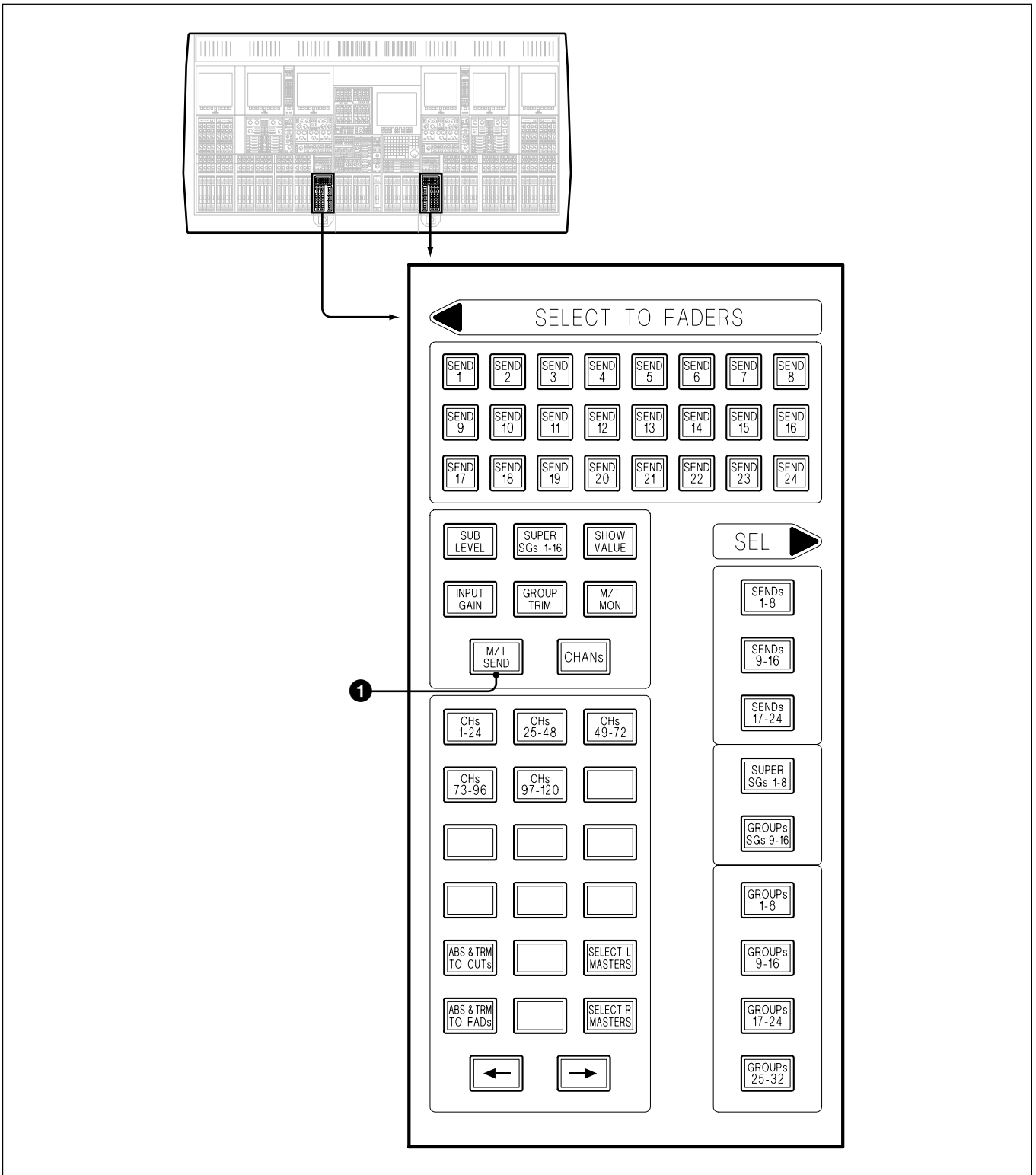

### ❶ MT SEND Push-Button

Sets the faders in the channels sections to control the level of the Multitrack Sends which feed the M/T Busses set up as Stems. Make sure this button is selected before proceeding.

# 4-13 Multi-Step Set-up

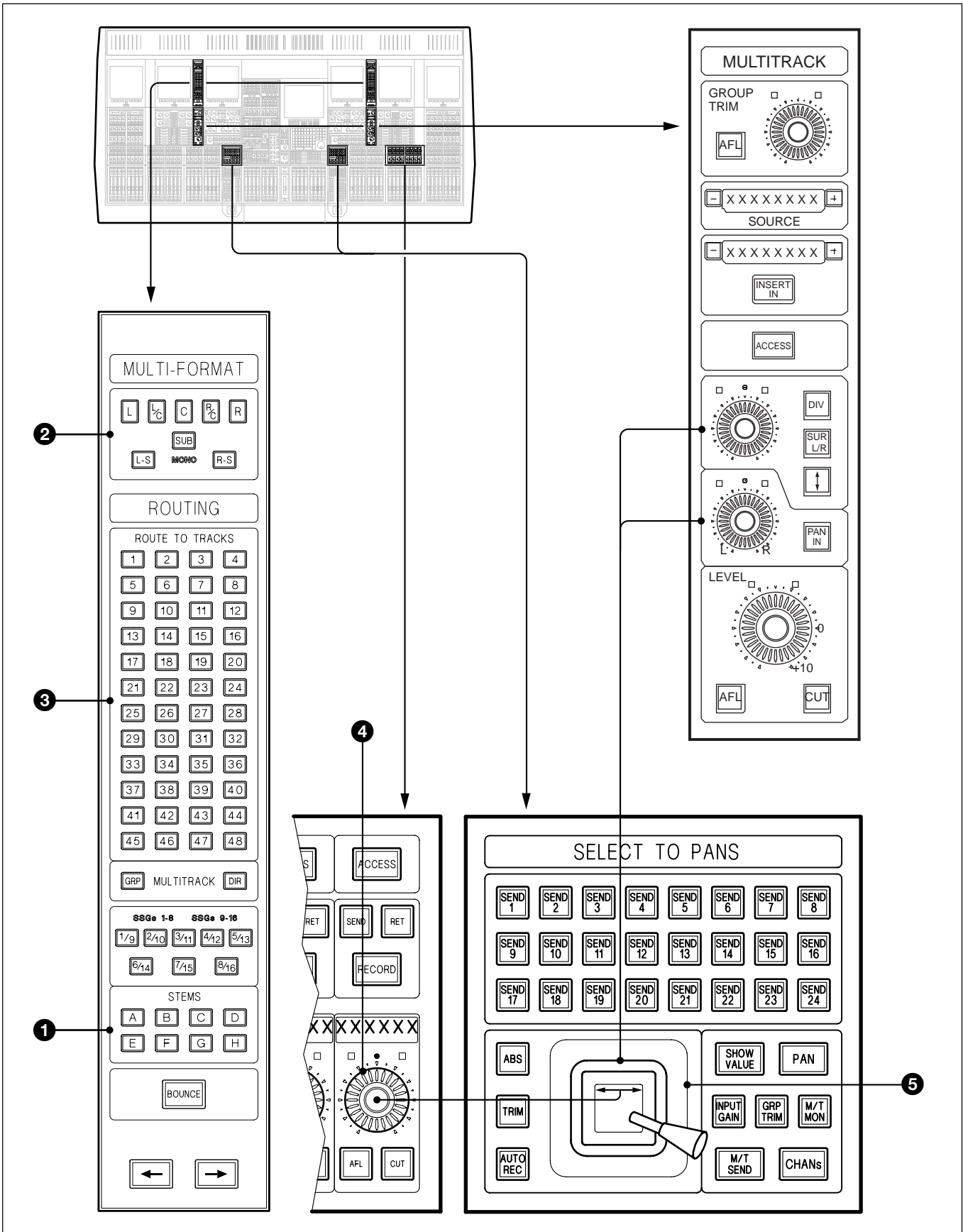

Multi-Channel routing and surround panning

## Multi-Channel routing and surround panning

The following applies to the channels which are the sources for Multi-Channel Stems.

### ❶ STEMS

Press one of A-H to select the desired stem destination. The button will light and its button in the ROUTE GUI will turn red. Buttons A-H inter-cancel. The system can be configured, via the ‘Config’ set-up file, so that routing selections for the current Stem are cleared automatically on selection of another Stem.

### ❷ MULTI-FORMAT Routing Buttons

The surround routing buttons are laid out in the form of a surround sound LS layout. Only those consistent with the format selected in the master section will be operable. They are assigned to buttons in the ROUTE TO TRACKS section in the Multi-Format set-up.

When a surround routing button is selected, it lights and so does the track button which is assigned to it in the set-up. The ROUTE GUI reflects this operation too by highlighting both buttons in red.

### ❸ ROUTE TO TRACKS Routing Buttons

Allow routing selections direct to Tracks, independent of whether a Track is assigned to a Stem.

### ❹ Definable Knobs

Pan is the fire-up default for the Definable Knobs, indicated by **PAN** being lit on the SELECT TO PANS panel. This allows control on a channel by channel basis for L/R pan settings for Stereo and L/C/R for surround modes.

### ❺ Touch Sensitive Motorised Joystick Panner

Any signal routed to two or more busses can be panned using one of the joysticks, one at each side of the control surface. The joysticks are assigned according to channel **ACCESS** buttons. They work in tandem with the pan knobs on the MULTITRACK panel and the L/R Pan above the faders, when faders are assigned to control M/T Send level. Any Pan can be used as they all track each other. If one is put into automation write, the others will follow automatically. The joystick will move according to automated moves and the **AUTO REC** push-button lights when the joystick is touched.

#### Note

*The Surround Routing buttons in the MULTI-FORMAT section of the Routing panel and panners will always operate on whatever function is assigned to the Faders, via the SELECT TO FADERS panel.*

*The functions of the individual controls on these panels are described in more detail in Chapter 6.*

### Behaviour of Routing in general.

The routing options and behaviour vary considerably depending on whether the system is operating in STEREO or MULTI-FORMAT modes. What follows is a summary:

#### STEREO Mode

'ROUTE TO TRACKS' section ③ allows panning strictly between Odd and Even tracks only. MULTI-FORMAT buttons ② are not operational.

- **Selecting either just ODD or EVEN tracks.**

A Post Fader signal will be fed directly to the Odd or Even tracks. The M/T **[PAN IN]** button is not operational.

- **Selecting at least one ODD and one EVEN track.**

A Post Fader signal will be fed directly to the Odd and Even tracks. Selecting the M/T **[PAN IN]** button will allow panning between the Odd and Even tracks.

#### MULTI-FORMAT Mode

Routing to busses can be accomplished in several ways:

- Using the MULTI-FORMAT section buttons ② at the top of the panel, which are mapped onto the track buttons stem by stem.
- Using the 'ROUTE TO TRACKS' buttons directly.
- A mixture of the two above to multiple stems.

#### ROUTING SELECTIONS for the ACTIVE STEM

The 'Active Stem' is the one selected and lit in section ①.

- **Selecting a single button in the MULTI-FORMAT section ②**

The track button, one of 1-48, mapped in the stem set-up to the one pressed, will light and a Post Fader signal will be fed directly to that track. The M/T **[PAN IN]** button is not operational.

- **Selecting two buttons in the MULTI-FORMAT section ②**

The track buttons, two of 1-48, mapped in the stem set-up will light and a Post Fader signal will be fed directly to those tracks. Selecting the M/T **[PAN IN]** button will allow panning between those tracks, using the PAN in the Multitrack panel or the Definable knobs, one above each fader.

The full range of the PAN knob is operational between the tracks whilst the Motorised Joystick will be mapped to the shortest path. If the Joystick is moved out of that path it will spring back when released.

#### Note

The **[JOYSTICK EN]** button must be selected in the centre section for the Joysticks to be operational.

- **Selecting more than two buttons in the MULTI-FORMAT section ②**

The track buttons, from 1-48, mapped in the stem set-up will light and a Post Fader signal will be fed directly to those tracks. Selecting the M/T **(PAN IN)** button will allow panning between those tracks as follows:

- The Motorised Joystick will be mapped to the exact area between the buttons. If the Joystick is moved out of that area it will spring back when released.

Panning using the knobs in the Multitrack panel works depending on which routing buttons are selected. The Definable knobs, one above each fader, are also operational, affecting front panning:

(The assignable knob in the Multitrack panel has three functions, Front/Back Pan, Surround Pan and Divergence)

- The L/R Pan knob operates across **(L)**, **(L/C)**, **(C)**, **(R/C)** and **(R)**.
- The Surround Pan, select **(SUR L/R)**, operates across **(L-S)** and **(R-S)**.
- Select the button **↕**, to pan the signal front to back.
- Select **(DIV)** to set the Divergence, clockwise for minimum spread.

### **ROUTING SELECTIONS for OTHER STEMS**

The 'Active Stem' is the one selected and lit in section ①. It is possible to route to other stems by selecting appropriate track numbers directly in the ROUTE TO TRACKS section ③.

- **Selecting one or more buttons in the ROUTE TO TRACKS section**  
Post Surround Pan signals will be fed to tracks according to the pan settings for the Active Stem.

### **OTHER ROUTING SELECTIONS**

Signals may be routed to tracks which are not set up in any of the Stems.

- **Selecting a single button in the ROUTE TO TRACKS section**  
A Post Fader signal will be fed directly to the track.
- **Selecting two buttons in the ROUTE TO TRACKS section**  
A Post Fader and Front L/R Pan signal will be fed to the two tracks. The L signal is fed to the lowest number track and the R to the highest.
- **Selecting more than two buttons in the ROUTE TO TRACKS section**  
A Post Fader and Front L/R Pan signal will be fed to the tracks. The L signal is fed to the lowest number track and the R to the rest of the higher number tracks.

## 4-13 Multi-Stem Set-up

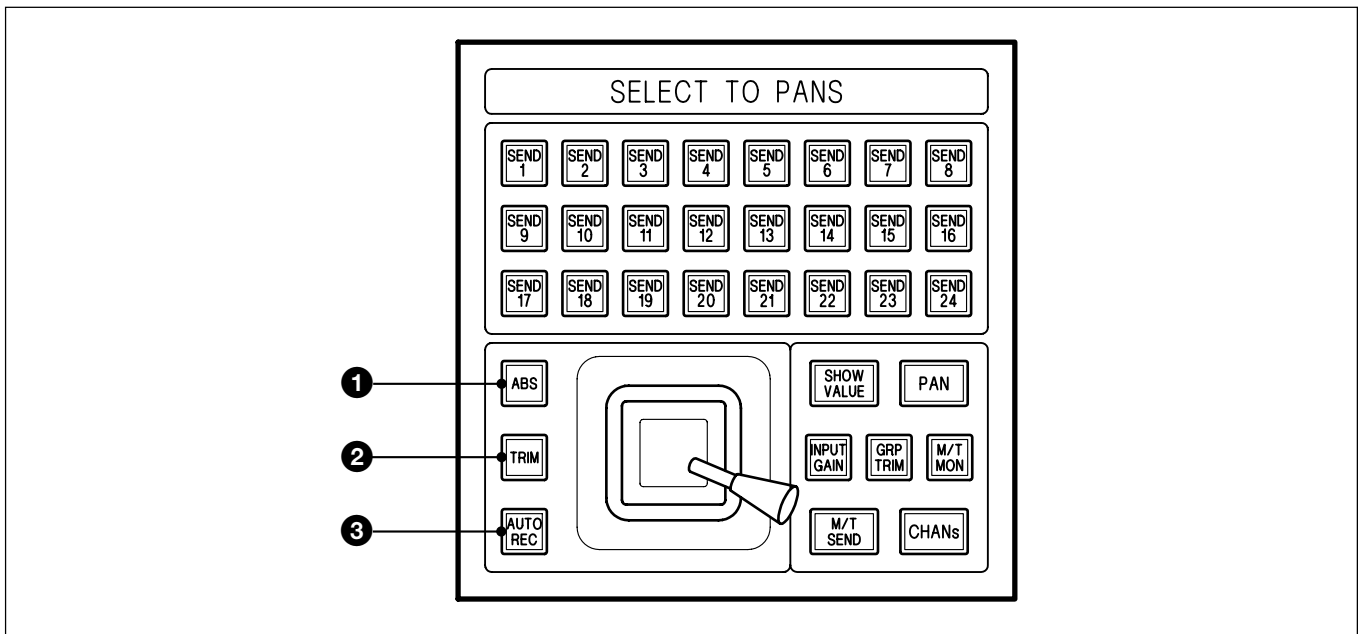

Automation switches for the Motorised Joysticks

### ❶ ABS Push-Button

Used to select 'ready absolute' status when automating joystick panning movements. The automation functions are exactly the same as those for faders (see Chapter 7).

### ❷ TRIM Push-Button

Used to select 'ready trim' status when automating joystick panning movements. The automation functions are exactly the same as those for faders (see Chapter 7).

### ❸ AUTO REC Push-Button

Used to switch the joystick into automation record according to the ABS or TRIM status. The automation functions are exactly the same as those for faders (see Chapter 7). This button lights to indicate the joystick is being touched.

## Routing and monitoring a signal

Once the set-up operations described earlier in this section have been completed:

- 1** Select **(M/T SEND)** on the SELECT TO FADERS panel and adjust faders on source channels to suitable level settings.
- 2** Select suitable destinations for the source channels using the MULTI-FORMAT routing buttons.
- 3** Monitor the levels visually on the meters related to the channels set up as Multi-Format Masters.
- 4** Listen to the mix via the Multi-Format Monitor described previously in 4-13-2.

### Sub Level

The level control for signals sent to the Sub channel works in two modes, depending on the routing selection.

#### Routed to SUB only

When the **(SUB)** routing button alone is selected for a channel, the level is controlled using the M/T Send Fader. Select **(M/T SEND)** on the SELECT TO FADERS panel.

#### Routed to SUB and other destinations

When the **(SUB)** routing button is selected along with at least one other routing button for a channel, the level is controlled using the M/T Send Fader and can be trimmed using the Sub Level Fader. Select **(M/T SEND)** or **(SUB LEVEL)** accordingly on the SELECT TO FADERS panel.

#### Note

*The setting of the Sub Level Fader will depend upon the sequence of button pushes. If **(SUB)** is selected first followed by one or more other routing buttons, the Sub Level Fader will be set at unity gain or 0dB. If **(SUB)** is selected after one or more routing buttons, then the Sub Fader will be set at infinity or fully closed.*

## 4-13 Multi-Stem Set-up

### 4-13-4 Stem Monitor Switching

Once stems have been set up, the tape sends and returns for each stem can be switched in tandem. The switching is operable in several ways, using the SENDS and RETS buttons by the machine remotes or using external switches linked to GPI (General Purpose Interface) connections. Switches may be operated locally.

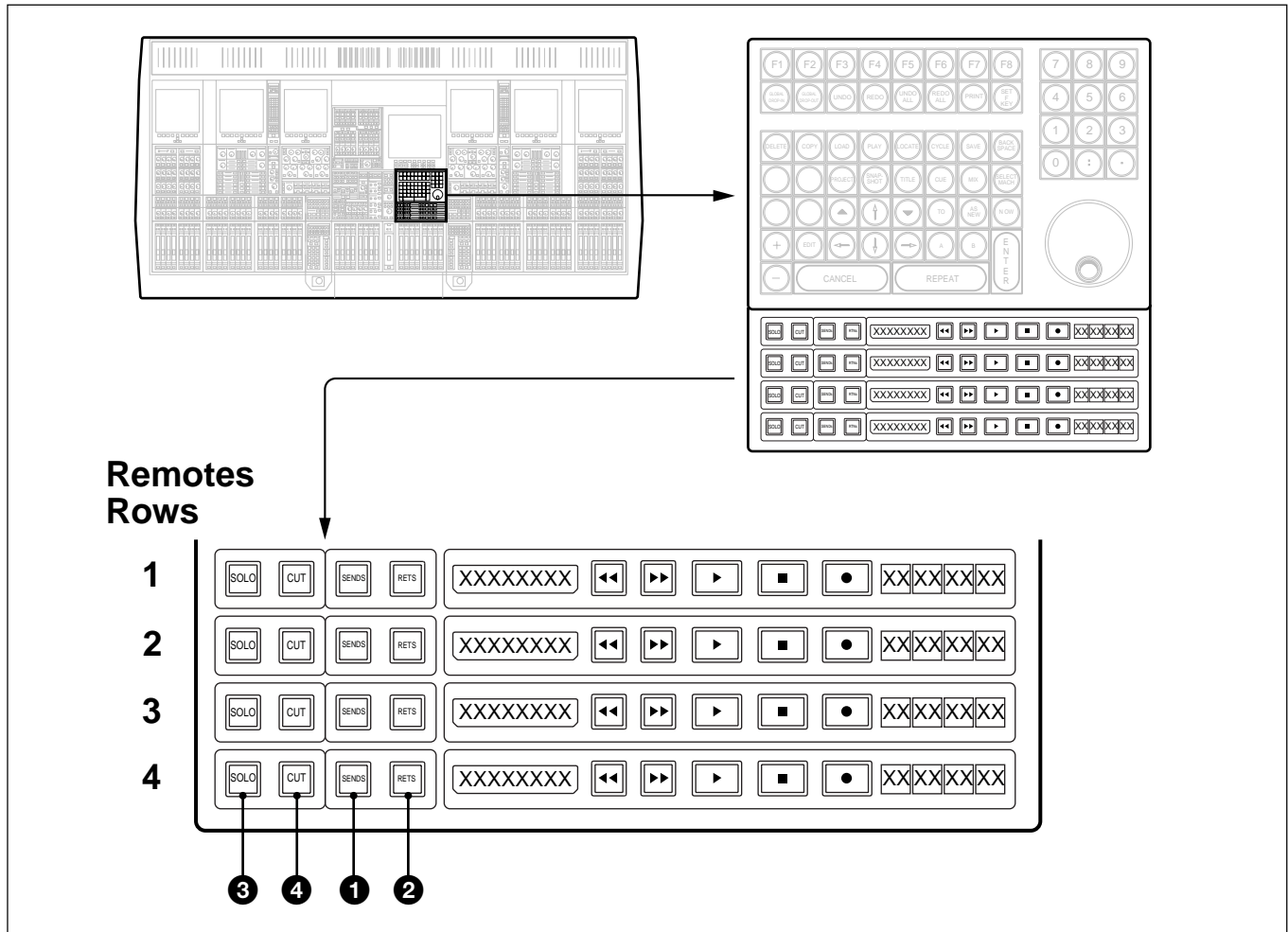

#### STEM monitor switch mapping

The fire-up default sets switch rows on the Control Keyboard to control stems as:

- Remotes Row 1 - Stem A
- Remotes Row 2 - Stem B
- Remotes Row 3 - Stem C
- Remotes Row 4 - Stem D

Mapping is fully flexible via GUI and can include Stems E-H. The GUI set-up operation is described in the following section.



## STEM monitor switch functions

### ❶ SENDS Push-Button(s)

Selects the sources being sent to tape for its stem or stems and inter-cancels with **[RETS]**.

### ❷ RETS (Returns) Push-Button(s)

Selects the return signal from tape for its stem or stems and inter-cancels with **[SENDS]**.

#### Note

*In Multi-Format Mode, the **[SEND]** and **[RET]** buttons for channels assigned as Stem masters also inter-cancel.*

### ❸ SOLO Push-Button(s)

Solos its stem or stems.

### ❹ CUT Push-Button(s)

Cuts its stem or stems.

## Stem monitor switching hierarchy

The monitor switching is controlled top down allowing the flexibility of local overrides at the slave channel level. Pressing either **[SENDS]** or **[RETS]** on the remotes panel in order to change the monitor source will re-synchronise slaves on the first press, if any channels have been overridden locally. A subsequent press will cause the monitor source to change.

The same principle applies to the master buttons in the GUI described in the next section, 4-13-5.

4-13-5 Stem Monitor Switching GUI Set-up

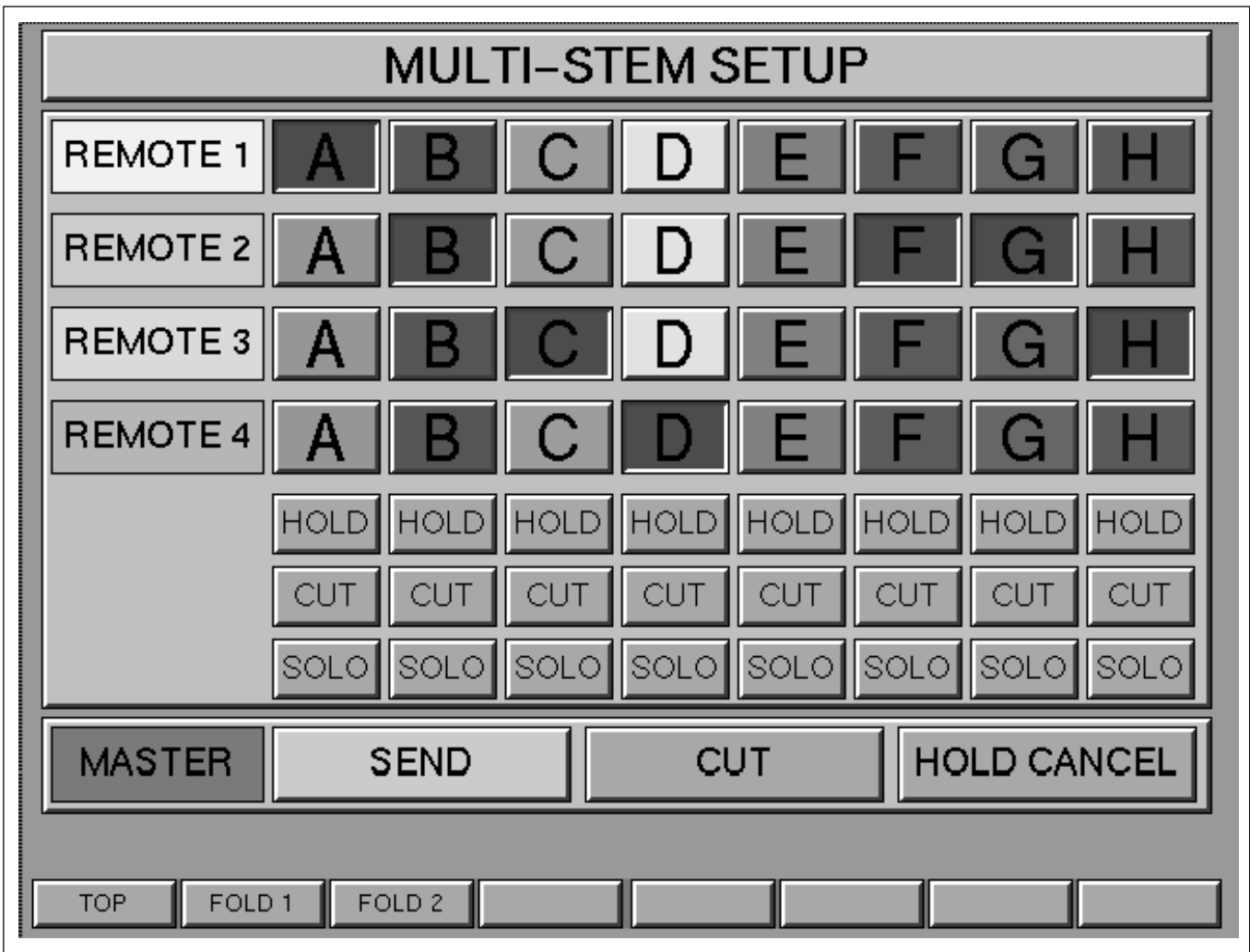

From the OXF-R3 LOGO page, click on M/STEM to view the MULTI-STEM SET-UP GUI.

**Assigning Stems using the GUI**

Any of the Stems A-H which are assigned to the monitor switches in the Remotes Rows will appear in red. Click on them to select or de-select accordingly.

The fire-up default sets switch rows on the Control Keyboard to control stems as:

- REMOTE 1 - Stem A
- REMOTE 2 - Stem B
- REMOTE 3 - Stem C
- REMOTE 4 - Stem D

---

### **HOLD button(s)**

Clicking on and highlighting in red any of the HOLD buttons in the GUI will cause the current monitor selection to be frozen, in that flipping between SENDS and RETS will only affect those not 'held'.

### **CUT button(s)**

Cuts its stem signal.

### **SOLO button(s)**

Solos its stem signal.

## **MASTER Row**

### **SEND button**

Selects the monitor source as the signal being sent to tape for all stems. The button then alternates to RETURN in readiness for selecting the signal returning from tape for all stems.

### **CUT button**

Cuts all stem monitor signals.

### **HOLD CANCEL button**

Cancels any HOLD buttons set on in the GUI.

### **The Softkeys for this GUI:**

- TOP - Selects the top level LOGO screen
- FOLD 1 - Selects FOLD-DOWN MATRIX 7.1 ➔ 5.1 ➔ LCRS
- FOLD 2 - Selects FOLD-DOWN MATRIX 5.1 ➔ STEREO ➔ MONO

4-13-6 Fold-Down Matrix GUIs

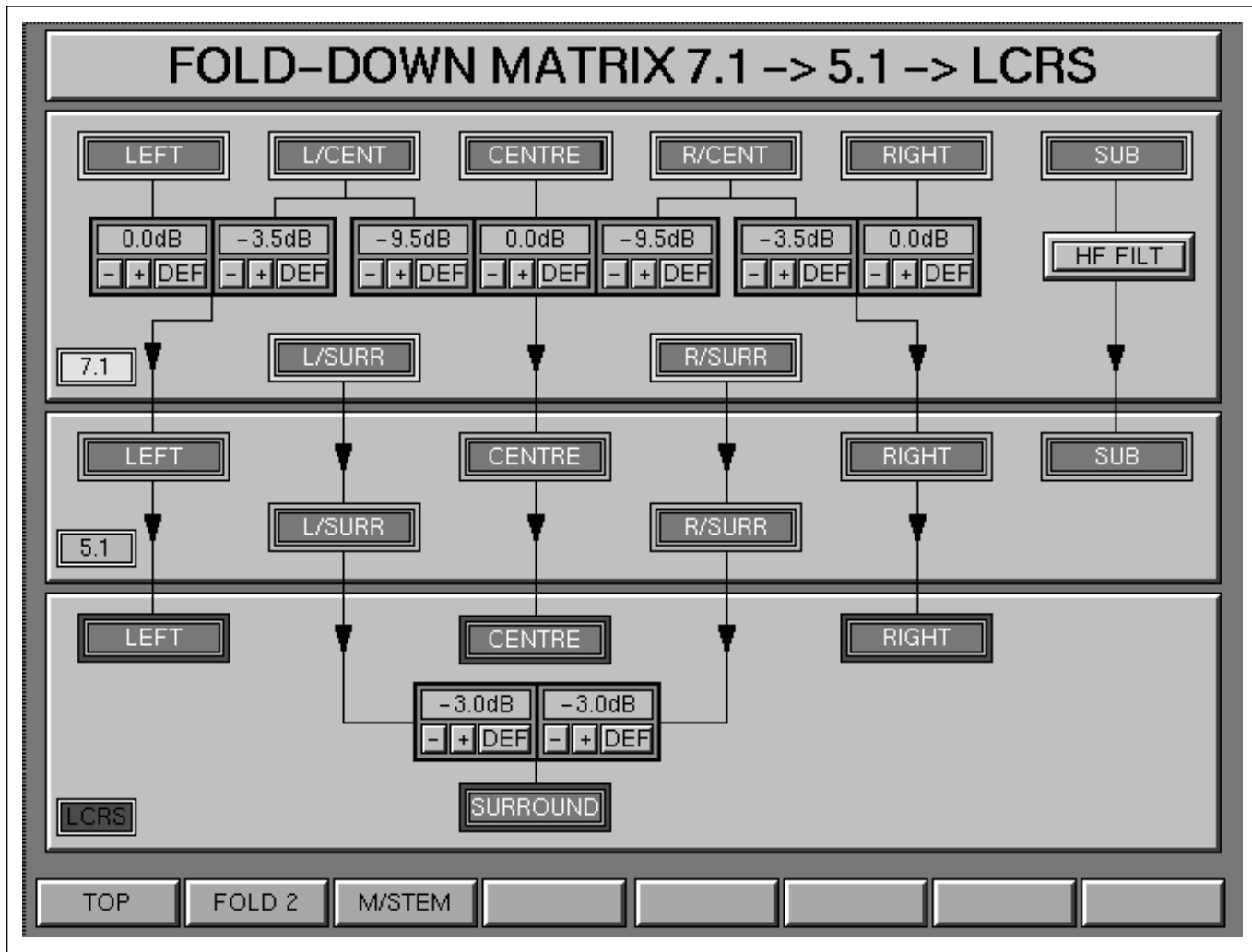

Chapter 4 Signal Paths

**General**

The two Fold-Down GUIs allow control of the levels for the fold-down of signal sources, when an output is derived from another which has a greater number of outputs. As an example, the Main Output Bus is set up for a 5.1 output and a Stereo Output is required simultaneously, or a Stereo version must be listened to for compatibility checking.

**Operation**

Each Fold-Down destination in the GUIs has a “control module” for each source. For example, when deriving 5.1 from 7.1, the 5.1 LEFT input is being fed from the LEFT and L/CENT of the 7.1 with a level control module for each.

Levels can be set in two ways:

- Click on **DEF** to set the Default values.
- Click on **+** and **-** buttons to set levels manually.

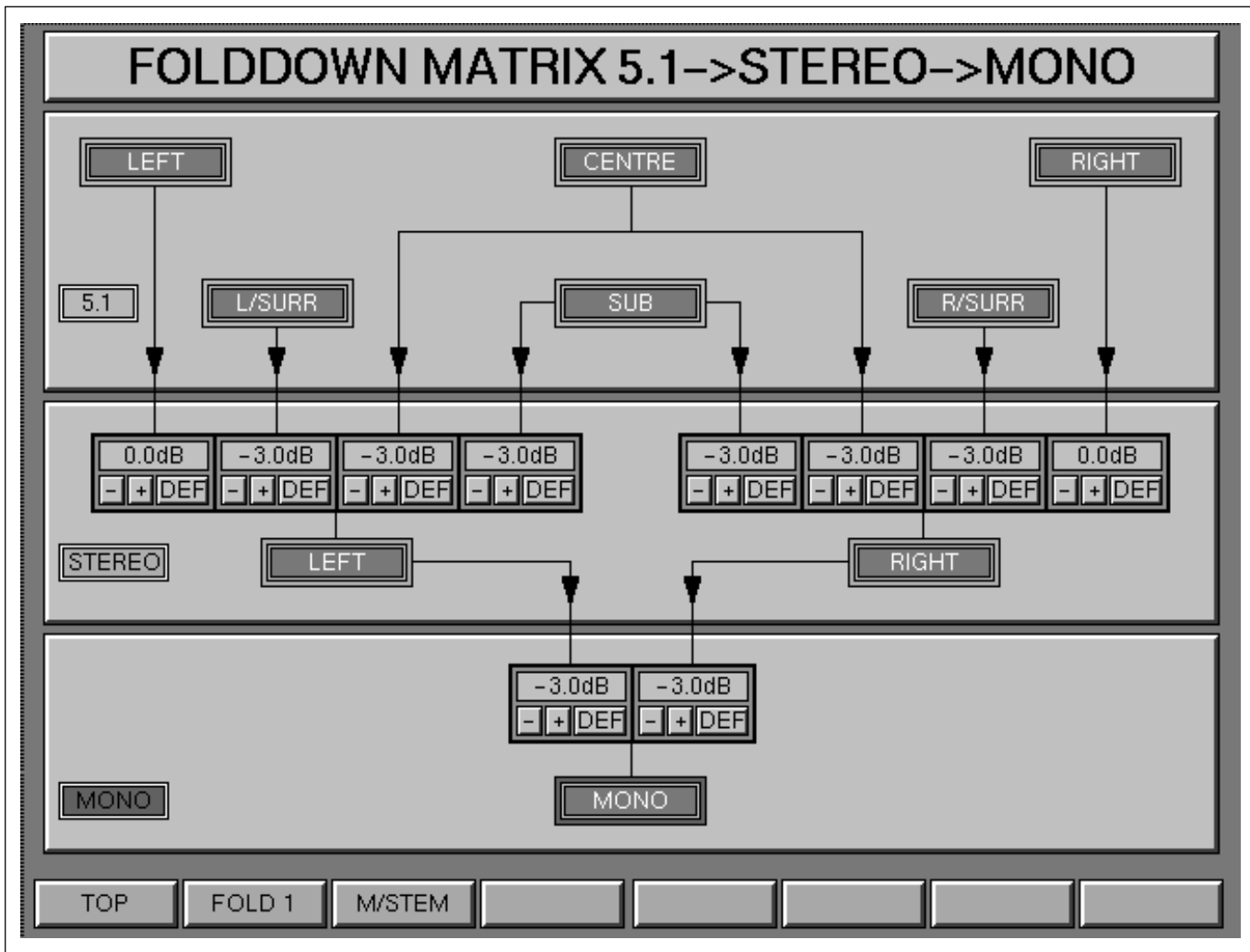

### Defaults

The Defaults are defined in the start-up Config. File settings.

### HF Filter

A low pass filter is available in the Sub channel when folding down from 7.1 to 5.1. Click on **HF FILT**, to the right of the GUI, to insert a filter with a corner frequency of 120Hz and a slope of 24dB/Octave.

### Snapshots

The Fold-Down settings are stored in Snapshots as part of the Centre Section. "CEN" must be selected in the Snapshots GUI in order for these settings to be recalled.

### The Softkeys for these GUIs:

- **TOP** - Selects the top level LOGO screen
- **FOLD #** - Alternates between FOLD 1 and FOLD 2
- **M/STEM** - Selects the MULTI-STEM SET-UP GUI

# Chapter 5 – Control Screens

In this chapter, the user will find a summary of the screens/menus available when operating the OXF-R3 system. They divide into 3 categories: System and general set-up; Session Management™ and those which relate to OXF-R3 mixer functions, such as input and output routing, equaliser and dynamics curve displays. Diagrams are included which show the inter-relationships between the screens available on the central LCD Master Control Screen, referred to as the Session Management™ Screen (SMS).

## Chapter 5 Contents

<b>5-1 The Master Control Screens .....</b>	<b>5-2</b>
<b>5-2 Channel Screens .....</b>	<b>5-5</b>
5-2-1 Routing GUI .....	5-8
5-2-2 I/O GUI .....	5-11
5-2-3 Equaliser & Filters GUI .....	5-28
5-2-4 Dynamics GUI .....	5-29
5-2-5 Preferences GUI .....	5-30
5-2-6 Master GUI (includes Main Bus Outputs) .....	5-39

# 5-1 The Master Control Screens

This suite of screen pages is available on the central LCD in the master section. It allows System-related set-up and Session Management™ functions which cover Artists/Projects, Titles, Mixes, Snapshots, Cues and Tracklists. More complex data and mix functions are provided as menu options. Functions involving sub-menus are arranged in a priority system such that the most used functions are the most readily accessible, where possible. In general, all of the main function screens are accessible from the softkeys located below the screen. Further sub-menus, for more specific operations, are available at subsequent levels below the main menus. At these lower levels, softkey functions allow the return to other main functions without the need to backtrack through multiple levels of the menu hierarchy.

The following diagrams show the inter-relationship of the Session Management™ screen pages and menus available to the operator. The numbers below the softkeys show the screen number (see left-side of diagrams) which is accessed by touching the relevant softkey.

Screen pages available on the centrally-located Session Management™ Screen (SMS) are shown in Chapters 6 and 7. This chapter illustrates and describes the Channel Screens available on the six LCD Screens, located three on either side of the OXF-R3 centre section.

**Notes:**

- 1 The SHUTDOWN softkey on the System screen page may be used to commence shutdown of the OXF-R3 system.*
- 2 The BACKUPS softkey is available on: the System screen; Artists/Projects & Titles screen; Assemble screen; Offline Automation screen; Global screen and Preferences screen. Select to implement system backup functions.*
- 3 Softkeys shown blank on the Logo screen diagram are not used.*

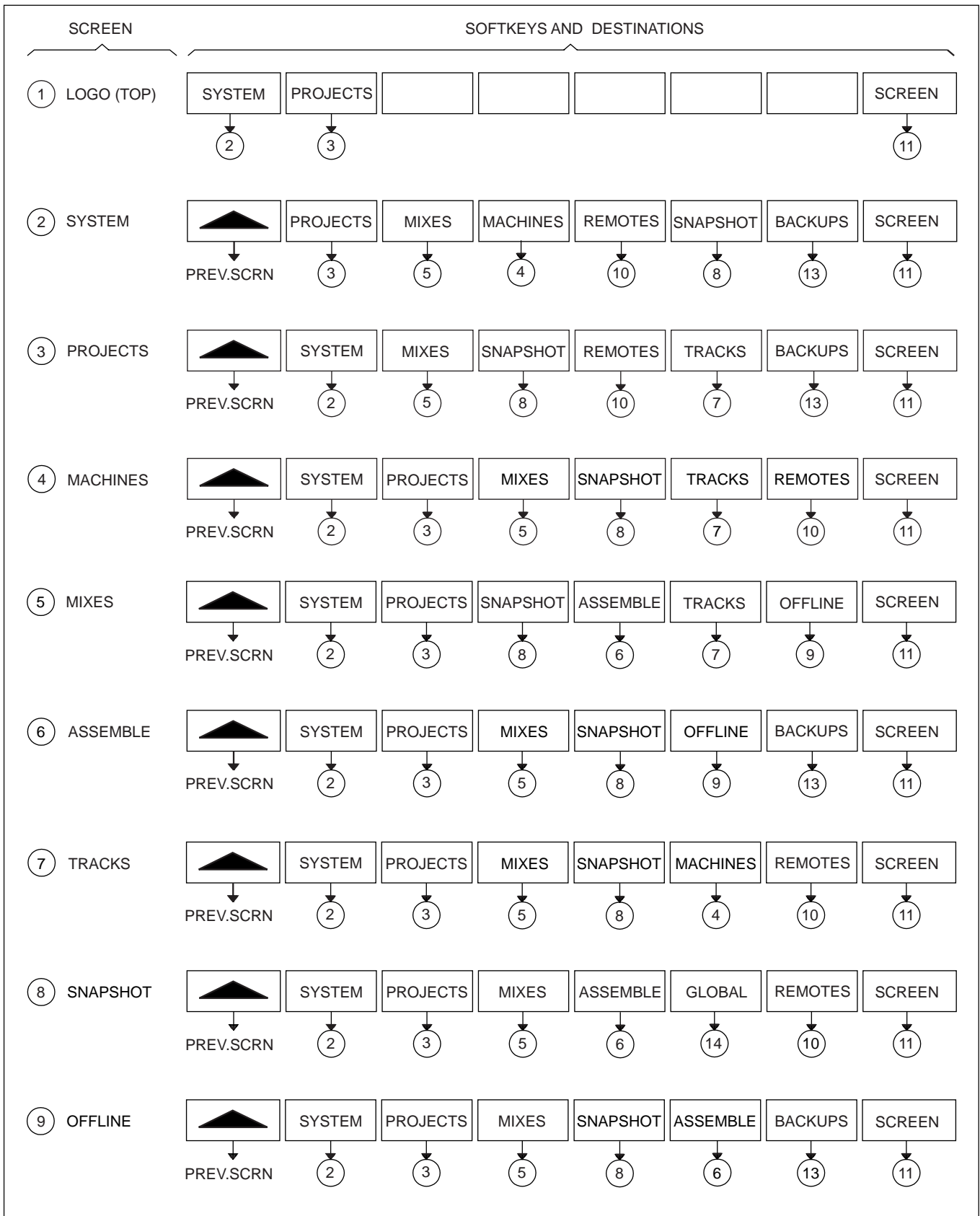

Control Screens structure (1)



# 5-1 The Master Control Screens

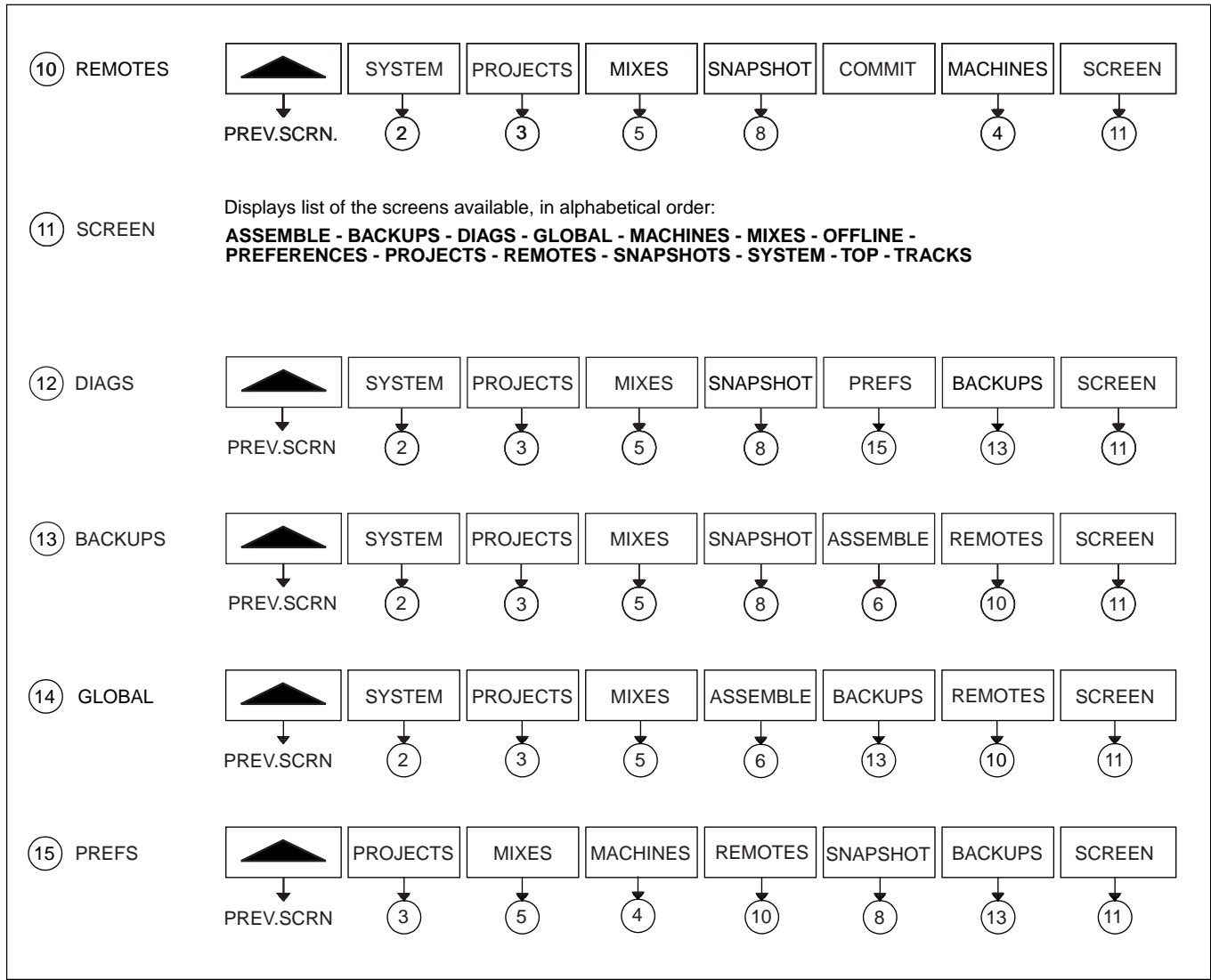

Control Screens structure (2)

## 5-2 Channel Screens

### The Channel Screens in general

Six LCD Channel Screens are provided on the OXF-R3 control surface, three either side of the centre section.

**Note:**

*Each Channel Screen can display any of the functions described. The softkeys below the channel screens give access to other functions. To select these functions, either click on the softkey or press button below the screen.*

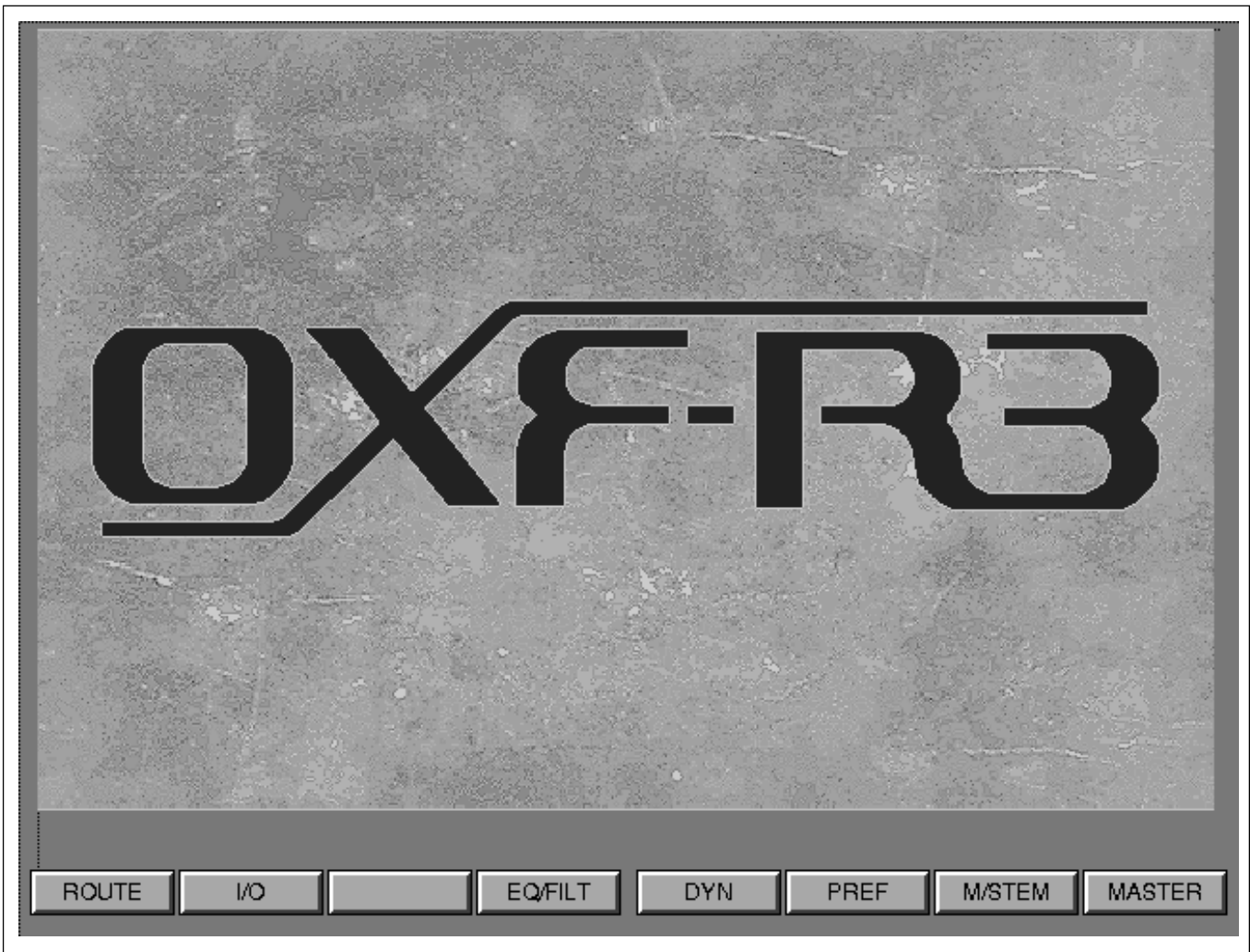

OXF-R3 Logo Screen (TOP)

The OXF-R3 logo screen has softkeys to the other Channel Screens as follows:

- **ROUTE** - Multitrack and Channel Output Routing GUI
- **I/O** - Channel Input & Output Assignments GUI
- **EQ/FILT** - Equaliser and Filters GUI
- **DYN** - Dynamics GUI
- **PREF** - Preferences GUI
- **M/STEM** - Multi-Stem GUI
- **MASTER** - Master Output Assignments GUIs (inc. SSGs & Sends)

To return to this screen at any time, select TOP from any other screen.

## 5-2 Channel Screens

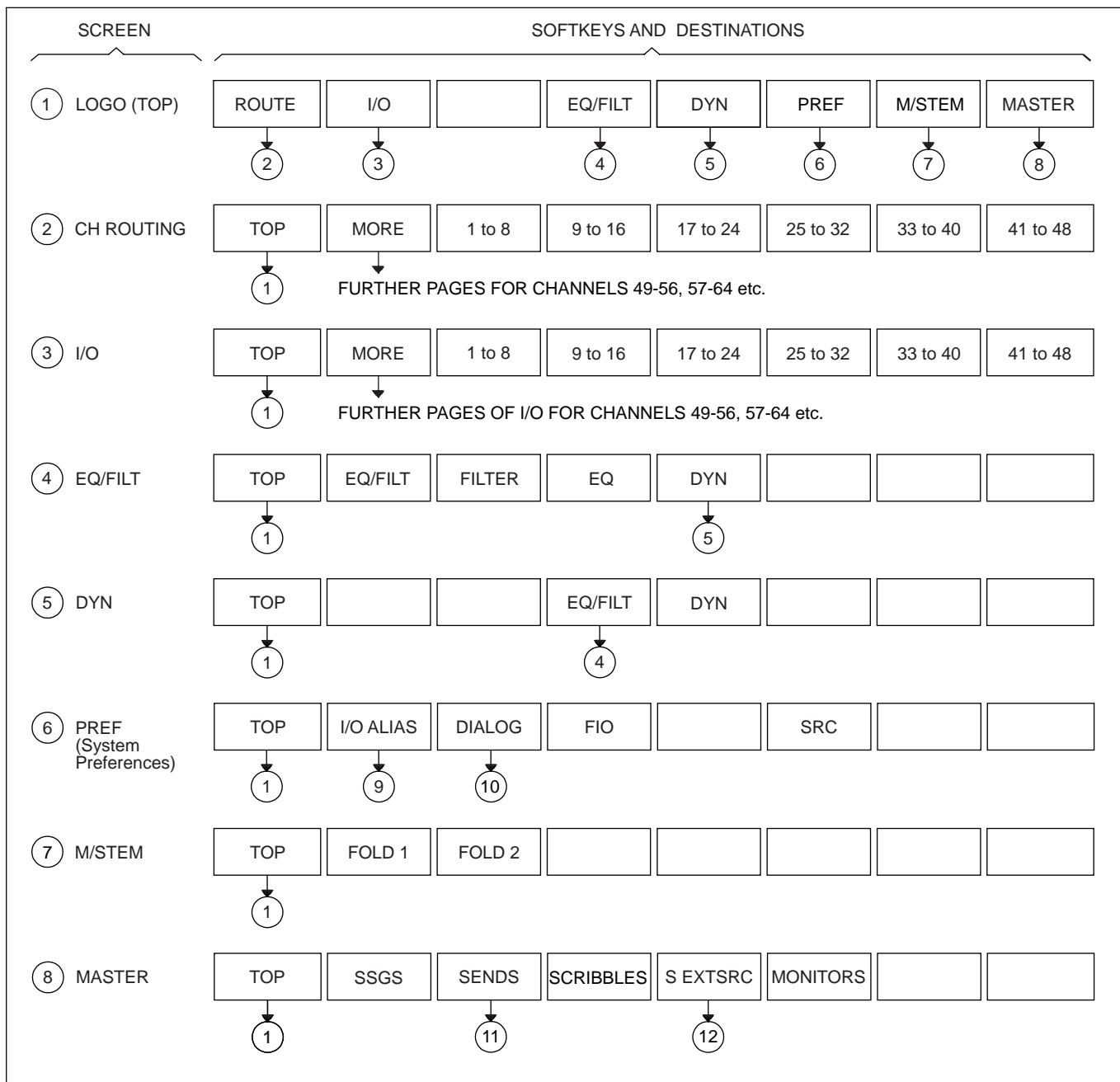

Channel Screens hierarchy, 1st level

All the console input and output assignments can be set and displayed on the channel screens. They include MIC, LINE and M/T Inputs, INSERT Sends and Returns. The MASTER GUI is used to assign all bus outputs, Monitor LS and External Source inputs.

GUIs related to EQ, Filters and Dynamics allow their transfer curves to be displayed.

Preference pages allow 'real' labels, such as MIC 1, to be set for I/O. Each category of I/O has a page that allows custom electronic scribble names to be specified, which appear in the naming pop-ups.

A Fast Insert set-up facility allows I/O (an input and an output) plus a name to be set as a single entity. A single click on that name in the Fast Insert pop-up assigns a send destination, a return source and an electronic scribble name simultaneously.

A Sample Rate Converters (SRCs) set-up GUI allows SRCs be assigned to AES inputs. There is an SRC label local to each digital input/output to indicate the inclusion of an SRC.

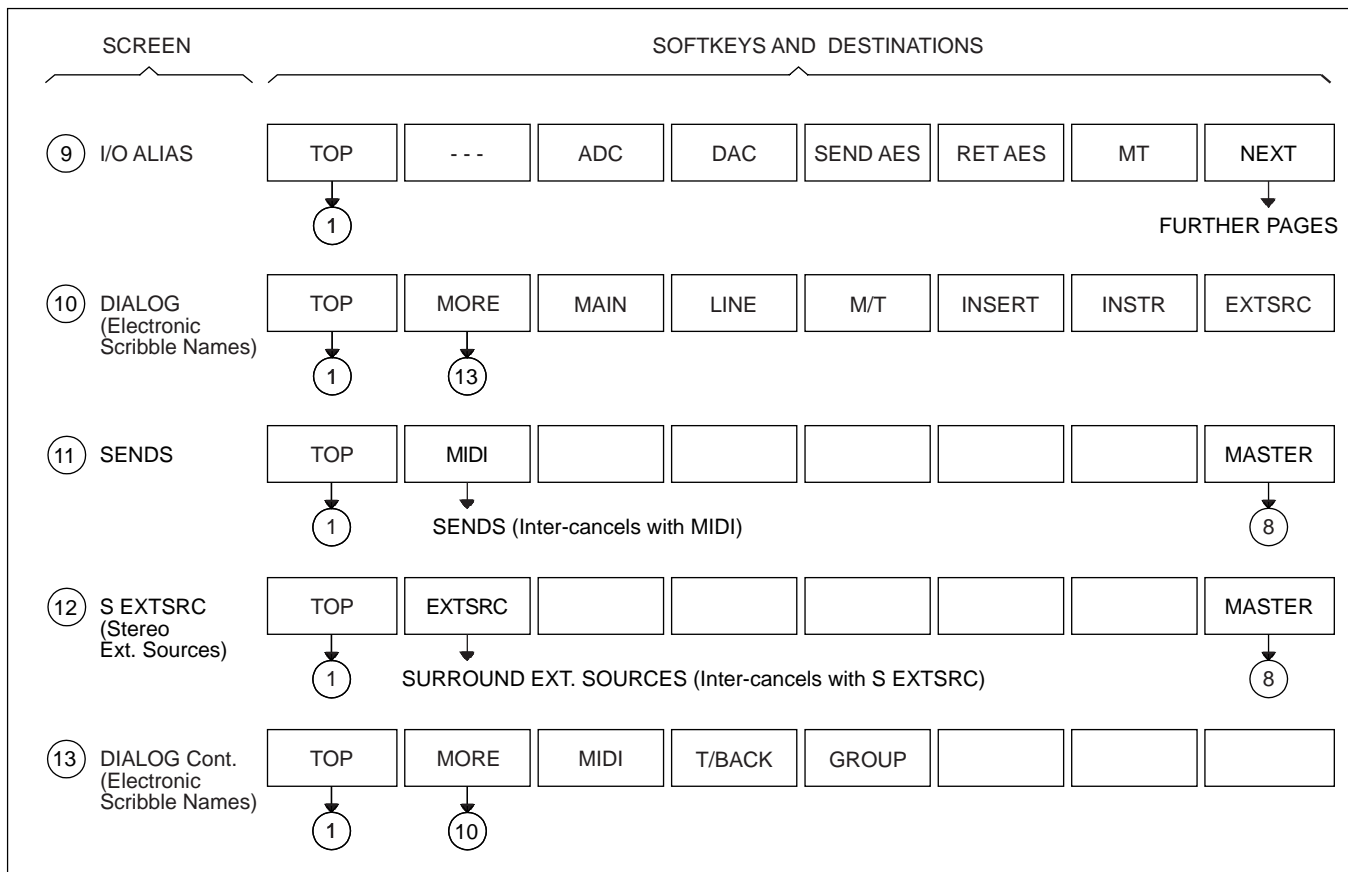

Channel Screens hierarchy, 2nd and 3rd level

**Note:**

Description of the M/STEM GUI (Multi-Stem Set-up) and the two related Fold-Down GUIs are not included in Chapter 5. Please see Chapter 4 for details of these GUIs.

### 5-2-1 Routing GUI

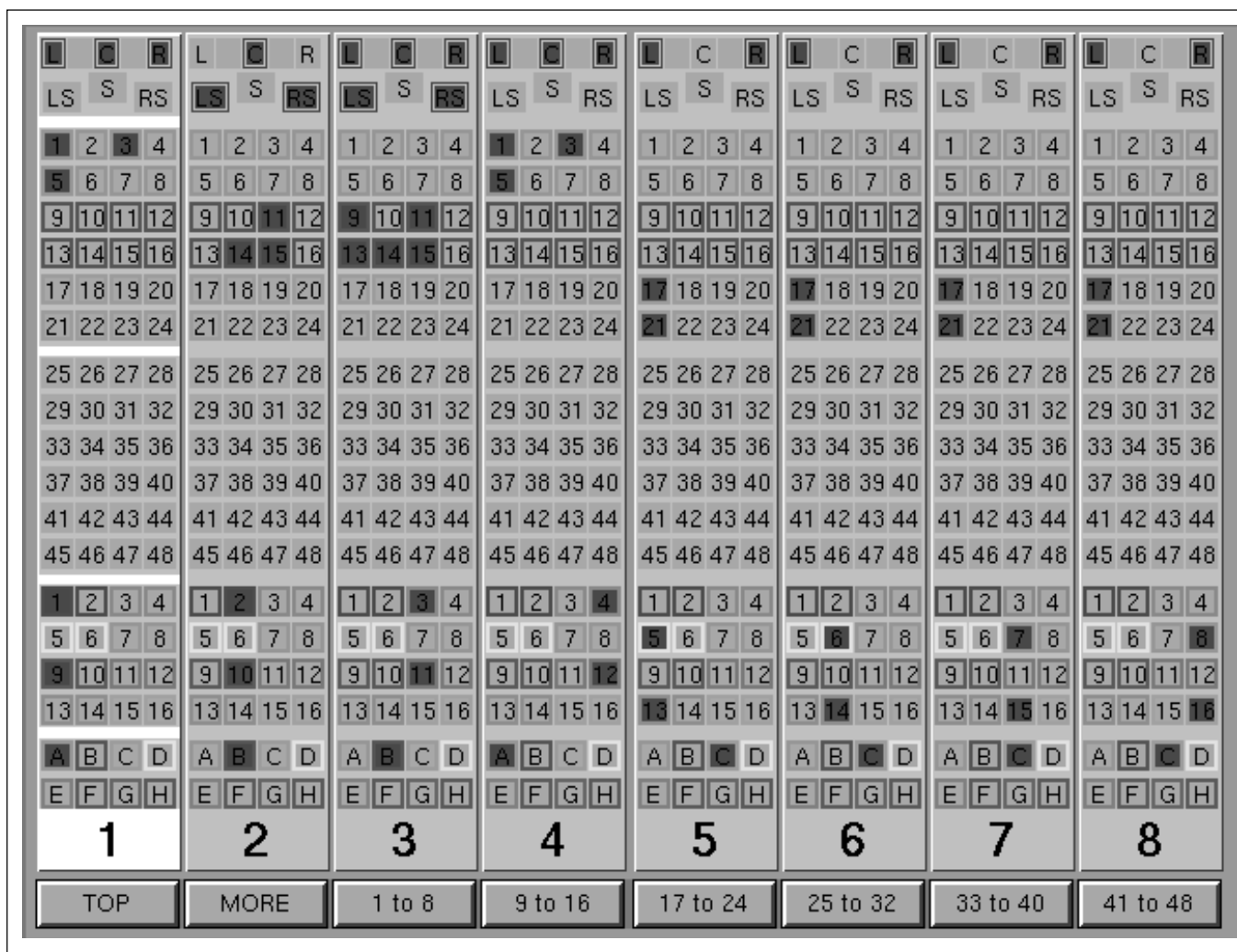

Routing GUI layout

#### General

The Routing GUI displays the channel output routing buttons for 8 channels according to the bank of faders below it, and which faders page is selected on the SELECT TO FADERS panel. For example, if channels 1-24 are selected to the faders and the ROUTING GUI is selected for the middle screen, it will display routing buttons for channels 9-16. There is just one set of actual routing buttons on the ROUTING panel at each side of the control surface, between the second and third screens. Therefore a single channel strip is highlighted to indicate which channel the routing switches are assigned to control. This is set according to the channel currently accessed.

The GUI has been designed to reflect the physical layout of the buttons on the panel. Operations of the real routing switches will be reflected on the screens. Buttons can also be selected via Trackerballs. Press **SELECT** below any GUI in order to set the cursor to the centre of that screen. Direct the cursor with the Trackerball and press the central red button

above the Trackerball to operate button. All routing assignments are indicated by buttons turning red.

To display other groups of 8 channels, click on the appropriate softkey at the bottom of the GUI or push its button below the screen. Select MORE for further groups of channels.

### Upper Surround buttons

The set of 8 buttons at the top of the GUI, set out in a 7.1 LS arrangement, indicate surround routing assignments set by the buttons in the MULTI-FORMAT section of the ROUTING panel. The buttons that are operational at any one time depend on the format set in the centre section. (See Chapter 4 for details)

They set assignments for the Main Output Bus or the M/T Busses, depending on which is selected on the SELECT TO FADERS panel. But note that assignments to M/T Busses are possible only if at least one stem has been assigned to the M/T Busses (see Chapter 4 for details).

If  CHANS is lit, the assignments for the Main Output Bus are displayed and changes can be made using the buttons on the ROUTING panel, or using a Trackerball and associated buttons. If  M/T SEND is lit, then these buttons display Stem assignments for the current stem.

### Stem buttons A-H

These buttons, in the lower section of the GUI, inter-cancel and select which stem the 8 buttons in the LS layout are assigned to.

#### Note:

*To avoid routing the same signals to multiple stems, there is an automatic clear option so that when a new stem is selected, assignments for the previous stem are de-assigned. Alternatively they can be cleared manually allowing assignments to multiple stems. See the “STEM CLEARING” option in the section for the PREFERENCES GUI, later in this Chapter.*

### Routing buttons 1-48

These buttons reflect routing assignments to the Multitrack or M/T Busses. Press any button on the ROUTING panel to make an assignment. The output of the M/T Send Fader controls the level. If the M/T Pan is switched in, then the L output feeds odd numbered busses and the R feeds the even.

Stems A-H, which utilise groups of M/T Busses and can be up to 7.1 wide, are set up via the centre section (see Chapter 4 for details). When stems have been set up, the tracks they have been assigned to are distinguished by colour coding of their outside borders. There is a different colour for each stem. They are automatically mapped to the buttons laid out in the form of a set of surround LS at the top of the GUI. So for example, if track 35 is assigned as the Centre track for a stem, just press the  C button and the track 35 button lights too.

Assignments made to tracks which are not set up as part of a stem, can be routed as normal, taking the output from the surround panner, L to odd numbered tracks and R to even.

### Super Send Group (SSG) buttons 1-16

These buttons, at the lower part of the GUI, just above the Stem buttons A-H, indicate assignments to the 16 Super Send Groups. The 8 SSG buttons on the ROUTING panel are labelled as , ,  and so on. They operate for SSGs 1-8 or 9-16 depending on whether  or  is selected in the centre section.

Since SSGs may be grouped, they are colour coded in a similar way to the stems with a coloured border around the outside of each button. The fire-up default for SSGs is 8 stereos, but they can also be set up as mono or surround groups. However, note that grouping cannot cross the boundary between the two pages, 1-8 and 9-16.

Super Sends can be set up as:

- **Mono**
- **Stereo**
- **LCR**
- **LCRS**
- **5.0**
- **5.1**
- **7.0**
- **7.1**

The setting up of SSGs is achieved in the centre section. Press and hold the  button for an SSG and wait until it turns amber. Any other SSGs in the same group will light yellow simultaneously. Press  buttons depending on whether more or fewer SSGs are required for that group. De-selecting SSG  buttons must be done from the outer to the inner buttons.

The signal feed to any SSGs have the same pan and level settings as those of the channel output feeding the Main Output Bus.

#### **Note:**

*An SSG can be set up to be wider than the Main Output Bus, e.g. Main could be set for Stereo, whilst an SSG could be 5.1. In this case the surround panning would be fully operational for the SSG whereas the Main Output Bus would receive L/R information only. L/R information includes in-place surround signals.*

## 5-2-2 I/O GUI

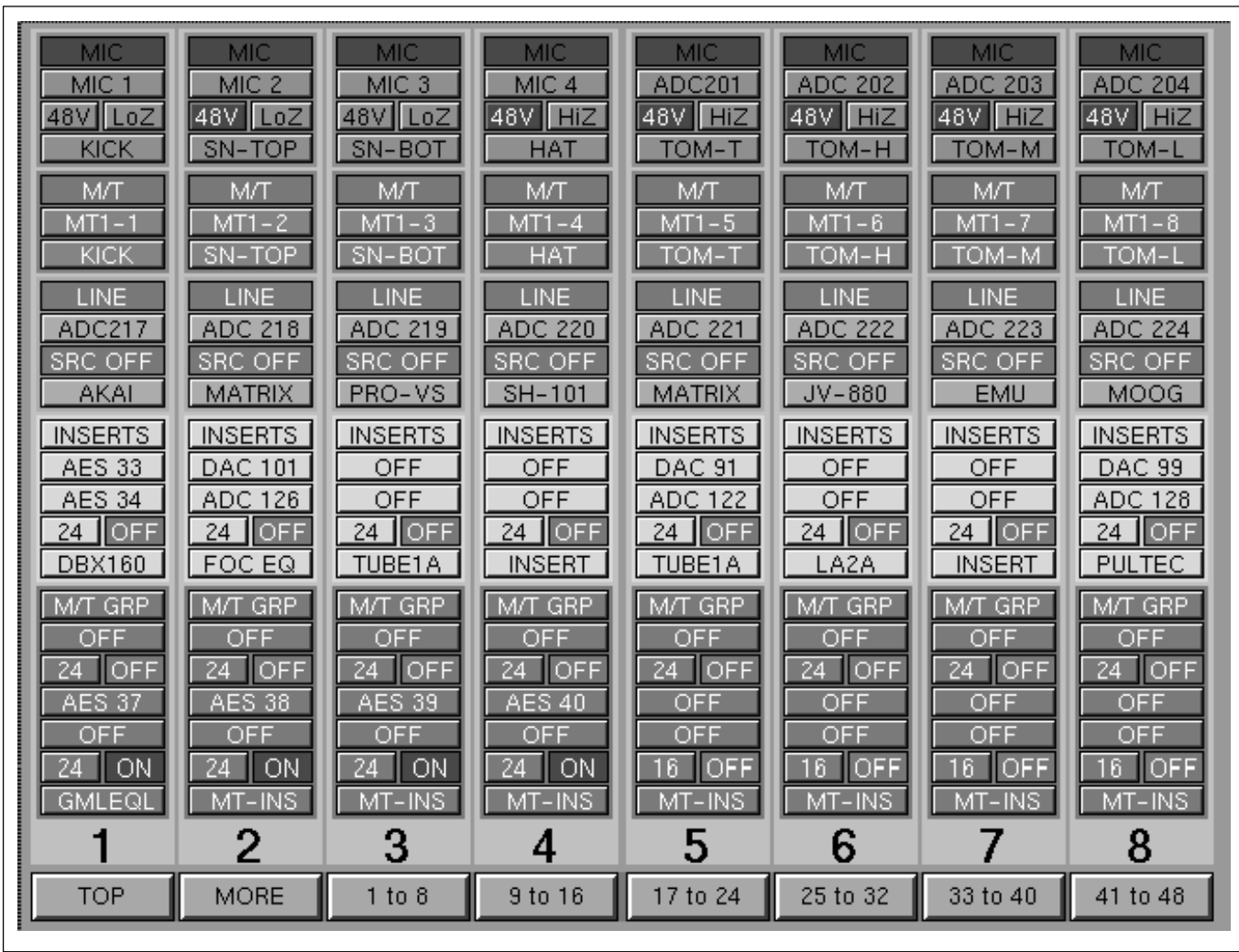

I/O GUI layout

**This GUI allows I/O assignments for:**

- **MONO channels**
- **STEREO Return channels**

The I/O GUI Screen contains dialogue blocks for the following I/O:

- **Mic Inputs**
- **Line Inputs**
- **Multitrack Inputs**
- **Channel Inserts**
- **Multitrack Group Send Outputs and Inserts**

Softkeys 3-8 may be used to select other groups of channels i.e. the first screen gives immediate access to channels 1-48. For further pages of channel groups, select the softkey MORE.



### **IMPORTANT**

#### **I/O Pop-up COLOUR CODING**

The pop-ups which allow I/O assignments are colour coded as follows:

##### **Text**

- **Black**            **4 Channel ADCs, DACs and AES I/O**
- **Yellow**         **8 Channel ADCs and DACs**

##### **Background colour of pop-up buttons**

- **Mauve/Blue**    **I/O SP-LINK-0 - General Purpose**
- **Light Blue**    **I/O SP-LINK-1 - General Purpose**
- **Light Blue**    **I/O SP-LINK-2 - Multitrack Machines**
- **Dark Blue**     **I/O SP-LINK-3 - Insert Device I/O**

#### **MADI Links in general**

The OXF-R3 has up to 4 SP-LINK modules each with 2 MADI circuits, allowing direct connection from the S/P Rack to remote I/O Racks and Dash tape machines. Possible I/O assignments for each loop are as below.

##### **Note:**

*The numbers of inputs and outputs vary according to system requirements, product type and software variant. The following are maximums.*

##### **SP-LINK-1**

General purpose for connections to inputs and outputs.

- **Analogue Inputs**        : **ADC-1 to ADC-200**
- **Analogue Outputs**      : **DAC-1 to DAC-200**
- **Digital Inputs**         : **AES-1 to AES-32 & AES-65 to AES-200**
- **Digital Outputs**        : **AES-1 to AES-32, AES-65 TO AES-80**

##### **SP-LINK-2**

I/O for connections to multitrack machines.

- **MADI Inputs**            : **MT1-1 to MT1-48 & MT2-1 to MT2-48**  
  **MD1-49 to MD1-56 & MD2-49 to MD2-56**
- **MADI Outputs**         : **MT1-1 to MT1-48 & MT2-1 to MT2-48**

##### **SP-LINK-3**

For connection specifically to Insert devices.

- **Analogue Inputs**        : **ADC-1 to ADC-200**
- **Analogue Outputs**      : **DAC-1 to DAC-200**
- **Digital Inputs**         : **AES-33 to AES-64 & AES-81 to AES-200**
- **Digital Outputs**        : **AES-33 to AES-64**

##### **SP-LINK-0**

General purpose for connections to inputs and outputs.

- **Analogue Inputs**        : **ADC-201 to ADC-312**
- **Analogue Outputs**      : **DAC-201 to DAC-312**
- **Digital Inputs**         : **AES-201 to AES-312**
- **Digital Outputs**        : **None**

### Indication of inputs and outputs already in use

The I/O is assigned using the GUIs illustrated on the following pages. Various pop-ups are used to display sources and destinations. Objects already in use will be indicated by [xxx]. For example if ADC10 is in use it will be indicated as [ADC10].

### Printing GUI pages

All GUIs displayed on the channel LCDs can be printed, one at a time, using the following procedure:

- Select the PREF page on one of the LCDs. It does not have to be the LCD displaying the GUI to be printed and often it is more convenient to use another.
- Click on PRINT in the box lowest right.
- Move the cursor into the screen to be printed if it is not already there. This can be done with a Trackerball or by pressing the SELECT button below the LCD just once.
- Once the cursor is displayed on the screen to be printed, press the SELECT button below the LCD to print the image.
- This is a one-shot operation and once the printing has been actioned the PRINT option in the PREF page reverts to SELECT.
- Click on PRINT once more to print a second or further GUI image.

**Note:**

*This print output function requires the system to be configured with a Postscript compatible printer.*

## 5-2 Channel Screens

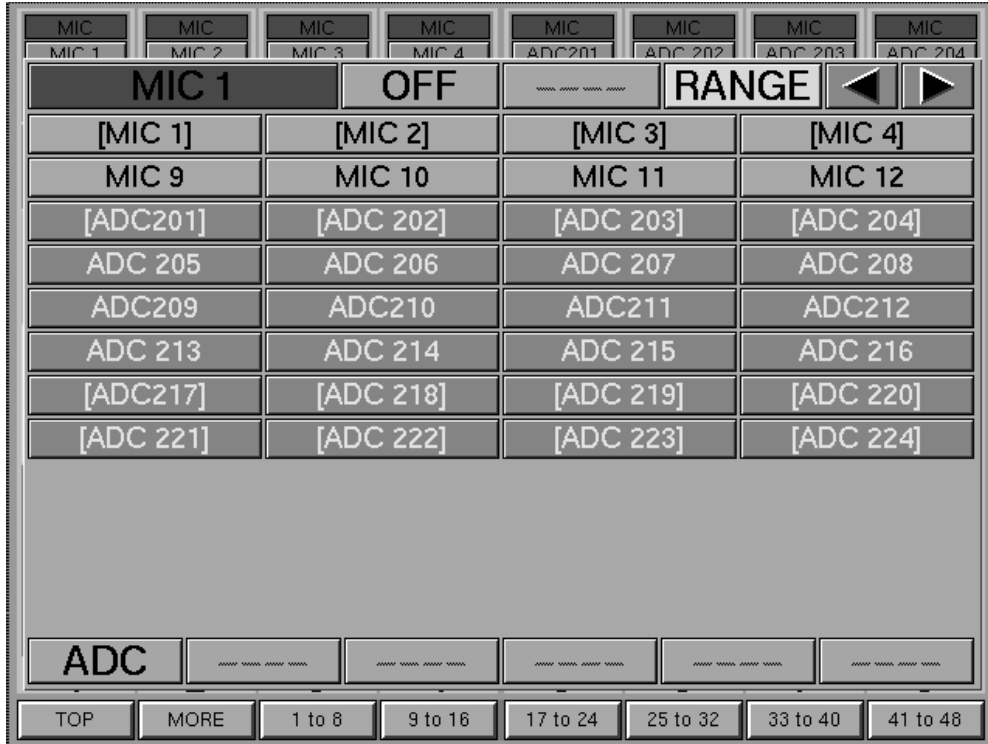

Figure A

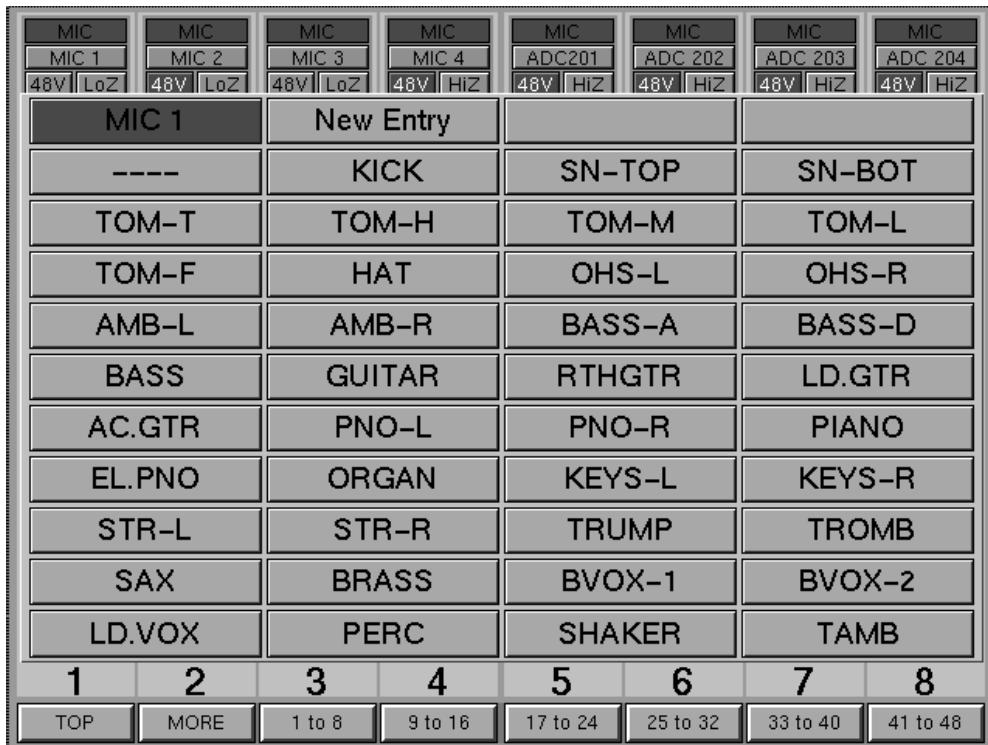

Figure B

MIC INPUT pop-ups

## Assigning MIC INPUTS

The upper 8 blocks in the GUI entitled MIC, each with 4 clickable fields below, are used for setting up MIC inputs.

### INPUT – Upper field

The upper field is used to select the ADC. Click on this field to display a pop-up dialogue box as shown in Figure A. The channel number is displayed in the pop-up according to the channel selected. If OFF is selected, there will be no source. Click on the required ADC number or name alias to connect that input to the selected channel.

### RANGE

A contiguous range of inputs can be assigned simultaneously. To assign a set of consecutive inputs to a number of consecutive channel inputs, ADCs 9-16 to channel Mic Inputs 1-8 as an example:

- Click on the upper field below the MIC legend of Channel 1 for the assignment pop-up shown in Figure A.
- Click on RANGE and its characters turn white and the background red.
- Click on the lowest number of the ADCs required, 9 in this example, and it highlights red.
- Click on the highest number of the ADCs required, 16 in this example, and ADCs 9-16 are assigned simultaneously to Mic Inputs 1-8.

#### Note:

*ADCs already in use will be “stolen” in all cases when the RANGE function is used.*

To set a range of inputs to off:

- Click on RANGE and its characters turn white and the background red.
- Click on OFF for a pop-up displaying the channel numbers.
- Click on the first and last of the range required.

### PHANTOM POWER – Second field left

The second field toggles between 48V ON and 48V OFF, for phantom powering microphones.

### INPUT IMPEDANCE – Second field right

The third field allows the user to toggle between a HIGH Z and LOW Z, high or low impedance, for the microphone input.

### NAME – Third field

The fourth (lowest) field is used to enter an electronic scribble name for the MIC INPUT. Click on this to display a pop-up as shown in Figure B. Either click on a name in the list or click on NEW ENTRY and use the QWERTY keyboard to type in a new name of up to 6 characters. Press ENTER when finished.

## 5-2 Channel Screens

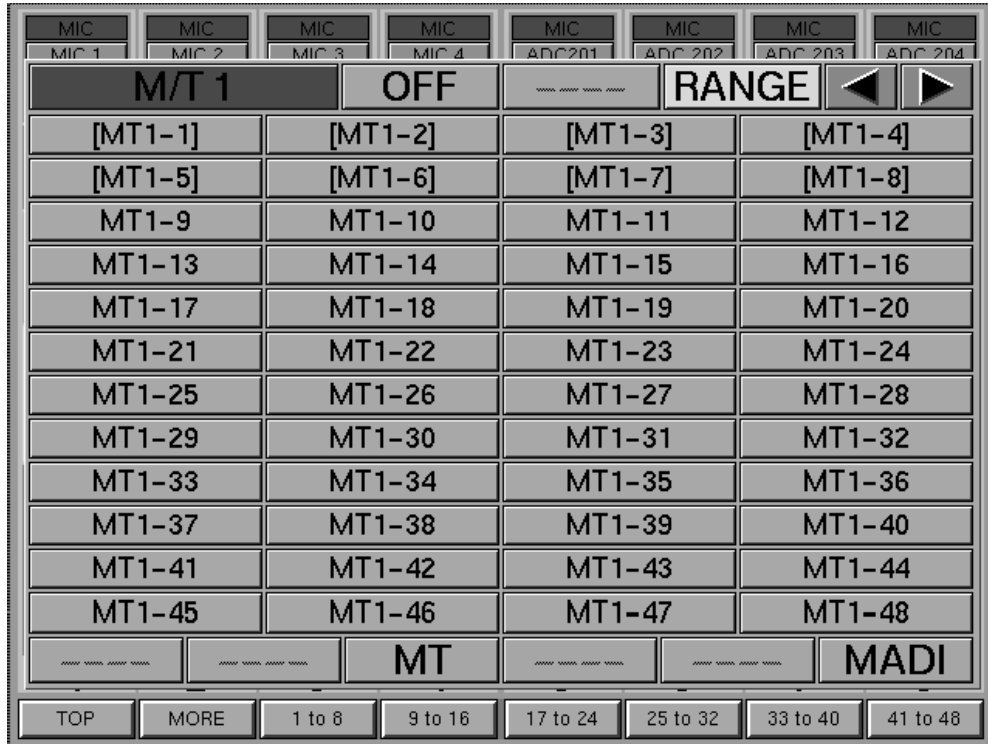

Figure A

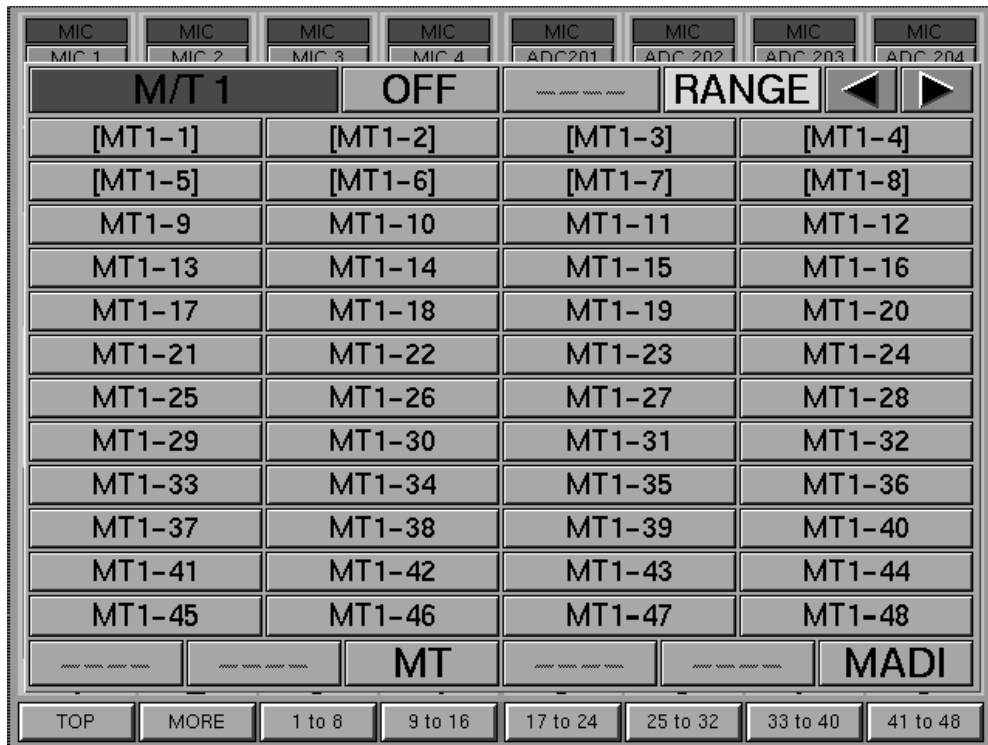

Figure B

M/T RETURN INPUTS GUI pop-ups

## Assigning M/T INPUTS

The second 8 blocks entitled M/T, each with 2 clickable fields below, are used for setting up the multitrack inputs.

### INPUT – Upper field

The upper field of each block is used to select the input source. Click on this to display a pop-up of the available sources as in Figure A. Click on the desired source to select it. The sources available include multitrack channels 1-48 and MAD I signals 49-56.

### RANGE

A contiguous range of inputs can be assigned simultaneously. To assign a set of consecutive inputs to a number of consecutive channel inputs, M/T Returns 1-48 to channel M/T Inputs 1-48 as an example:

- Click on the upper field below the M/T legend of Channel 1 for the assignment pop-up shown in Figure A.
- Click on RANGE and its characters turn white and the background red.
- Click on the lowest number of the M/T Returns required, 1 in this example, and it highlights red.
- Click on the highest number of the M/T Returns required, 48 in this example, and M/T Returns 1-48 are assigned simultaneously to Channels 1-48.

#### Note:

*M/T Returns already in use will be “stolen” in all cases when the RANGE function is used.*

To set a range of inputs to off:

- Click on RANGE and its characters turn white and the background red.
- Click on OFF for a pop-up displaying the channel numbers.
- Click on the first and last of the range required.

### NAME – Lower field

The lower field is used to enter an electronic scribble name. Click on this to display a pop-up as shown in Figure B. Either click on a name in the list or click on NEW ENTRY and use the QWERTY keyboard to type in a new name of up to 6 characters. Press ENTER when finished.

Click on ‘Track List’ at the top of the pop-up to load the name in the Track List for Multitrack machines MT1 or MT2 in the Session Manager™. These names are assigned using the central LCD. Click “All Tracks” to load all the names for MT1 or MT2.

#### Note:

*These options are available only if one or more outputs from MT1 or MT2 are actually assigned to inputs on the M/T INPUTS GUI. It is possible to load Track List names directly from the TRACK LISTS GUI. This is described in Chapter 7.*

## 5-2 Channel Screens

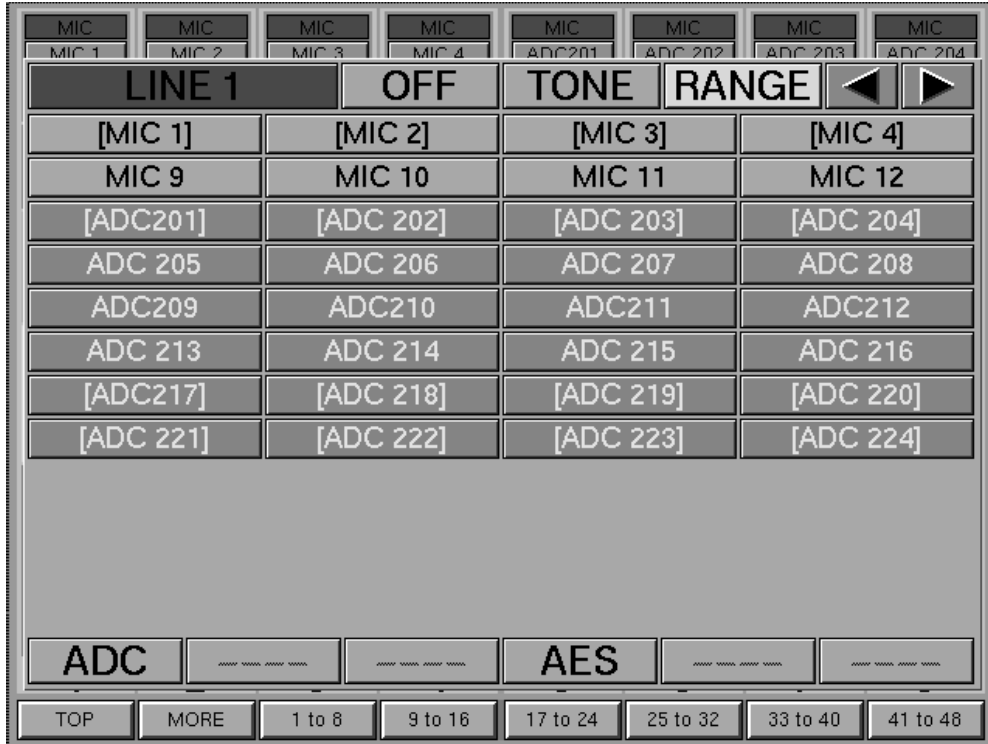

Figure A

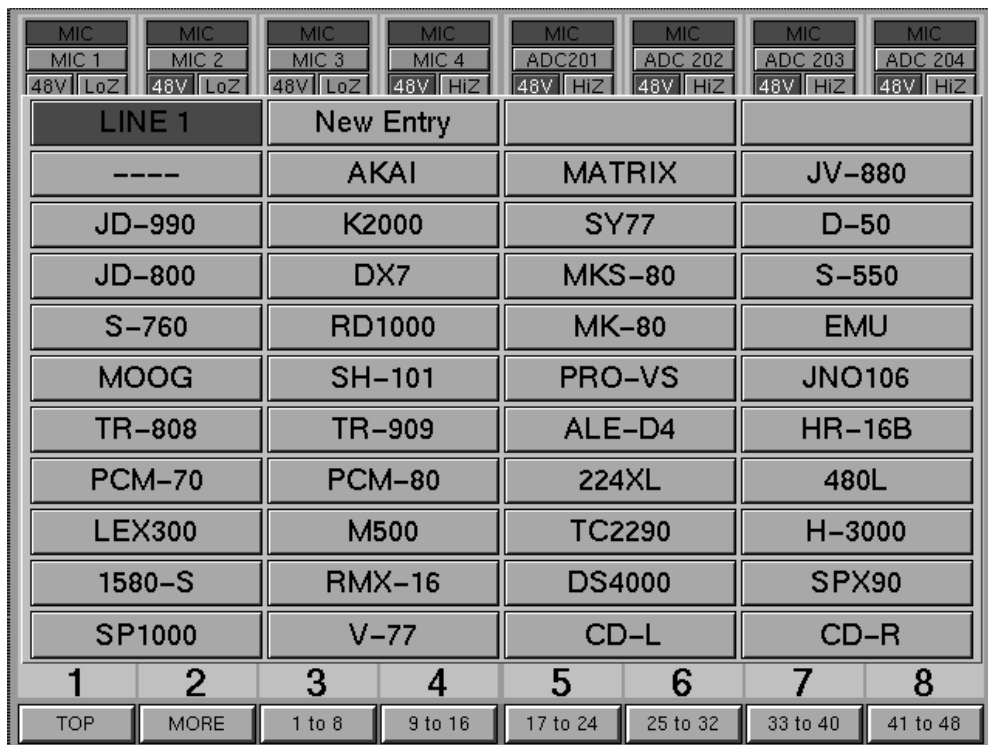

Figure B

LINE INPUTS pop-ups

## Assigning LINE INPUTS

The middle 8 blocks entitled LINE, each with 2 clickable fields below, are used for setting up LINE inputs.

### INPUT – Upper field

The upper field is used to select the I/O source. Click on this to display a pop-up as in Figure A.

If OFF is selected, there will be no input source. If TONE is selected, the source is the oscillator as set up in the console centre section.

To select a source, click on one in the list. These can be ADC (analogue) sources or AES (digital) sources, as numbered. Clicking on AES will swap from the ADC page (Figure A) to the AES page and vice versa.

### RANGE

A contiguous range of inputs can be assigned simultaneously. To assign a set of consecutive inputs to a number of consecutive channel inputs, ADCs 17-24 to channel Line Inputs 1-8 as an example:

- Click on the upper field below the LINE legend of Channel 1 for the assignment pop-up shown in Figure A.
- Click on RANGE and its characters turn white and the background red.
- Click on the lowest number of the ADCs required, 17 in this example, and it highlights red.
- Click on the highest number of the ADCs required, 24 in this example, and ADCs 17-24 are assigned simultaneously to Line Inputs 1-8.

#### Note:

*ADCs already in use will be “stolen” in all cases when the RANGE function is used.*

To set a range of inputs to off or assign the oscillator signal set at the master section:

- Click on RANGE and its characters turn white and the background red.
- Click on OFF or TONE for a pop-up displaying the channel numbers.
- Click on the first and last of the range required.

### SAMPLE RATE CONVERTER – Second field (Indicator)

This indicator turns red and reads “SRC ON” when a digital source is selected which has its SRC turned on. SRCs are controlled via the PREFERENCES GUI, described later in this chapter.

### NAME – Third field

The lower field is used to enter an electronic scribble name for the LINE INPUT. Click on this to display a pop-up as shown in Figure B. Either click on a name already displayed or click on NEW ENTRY and use the QWERTY keyboard to type in a new name of up to 6 characters. Press ENTER when finished.





CHANNEL FAST INSERTS pop-up

### Assigning CHANNEL INSERTS

The 8 blocks towards the bottom of the GUI entitled INSERTS, each with 5 fields (the title is a useable field too), are used to set up channel inserts. Inserts can be set up in two ways, using the pre-assigned FAST INSERTS via the upper field or by setting each item individually using the other fields.

#### FAST INSERT – Upper field

Clicking on the upper INSERTS field gives access to the FAST INSERTS pop-up. Each selection can have a pre-assigned input, output and appropriate name. These are set up via the PEF (Preferences) GUI described later in this chapter.

Click on the desired device name in the pop-up and its input and output will be connected simultaneously. The I/O device names will be displayed in the second and third fields and the actual device name will be displayed in the fifth scribble field. Selecting INSERT at the INPUT CHANNEL & INSERTS panel will display the device name in the dot character display.

Once actioned as a Fast Insert, the assignments to the other fields can be edited or set up on an individual basis as follows:

#### INSERT SEND – Second field

The second field is used to specify an I/O destination for the selected channel Insert Send. Click on this for the pop-up displaying possible

destinations. Figure A shows analogue destinations (DACs). Click on the desired DAC number to assign a Send. For a digital output, click on AES for the list of digital destinations. Further pages of related pop-ups can be accessed by clicking on ◀ or ▶. Click on OFF to disable a Send.

### **RANGE**

A contiguous range of Insert Sends can be assigned simultaneously. To assign a set of consecutive Insert Sends to a number of consecutive outputs, channel Insert Sends 1-4 feeding DACs 5-8 as an example:

- Click on the field below the INSERTS button of Channel 1 for the assignment pop-up shown in Figure A.
- Click on RANGE and its characters turn white.
- Click on the lowest number of the DACs required, 5 in this example, and it highlights red.
- Click on the highest number of the DACs required, 8 in this example, and DACs 5-8 are assigned simultaneously to channel Insert Sends 1-4.

#### **Note:**

*DACs already in use will be “stolen” in all cases when the RANGE function is used.*

To set a range of inputs to off:

- Click on RANGE and its characters turn white and the background red.
- Click on OFF for a pop-up displaying the channel numbers.
- Click on the first and last of the range required.

### **INSERT RETURN – Third field**

The third field is used to select the I/O Insert Return source for the channel. Click on this to display a pop-up similar to that shown in Figure B. Click on the desired analogue return source or click on AES for the digital return sources. Other functions related to the Return operate in exactly the same way as for the Insert Sends.

### **RANGE**

The Range function works for Insert Returns in the same way as it does for Insert Sends.

### **WORD LENGTH – Fourth field left**

The fourth field allows the channel Insert Send word length to be set, if the send is digital. Click on it to cycle through the word lengths 16 bit, 20 bit and 24 bits.

### **SAMPLE RATE CONVERTER – Fourth field right (Indicator)**

This indicator turns red and reads “ON” when a digital I/O is selected which has an SRC turned on. SRCs are controlled via the PREFERENCES GUI, described later in this chapter.

## 5-2 Channel Screens

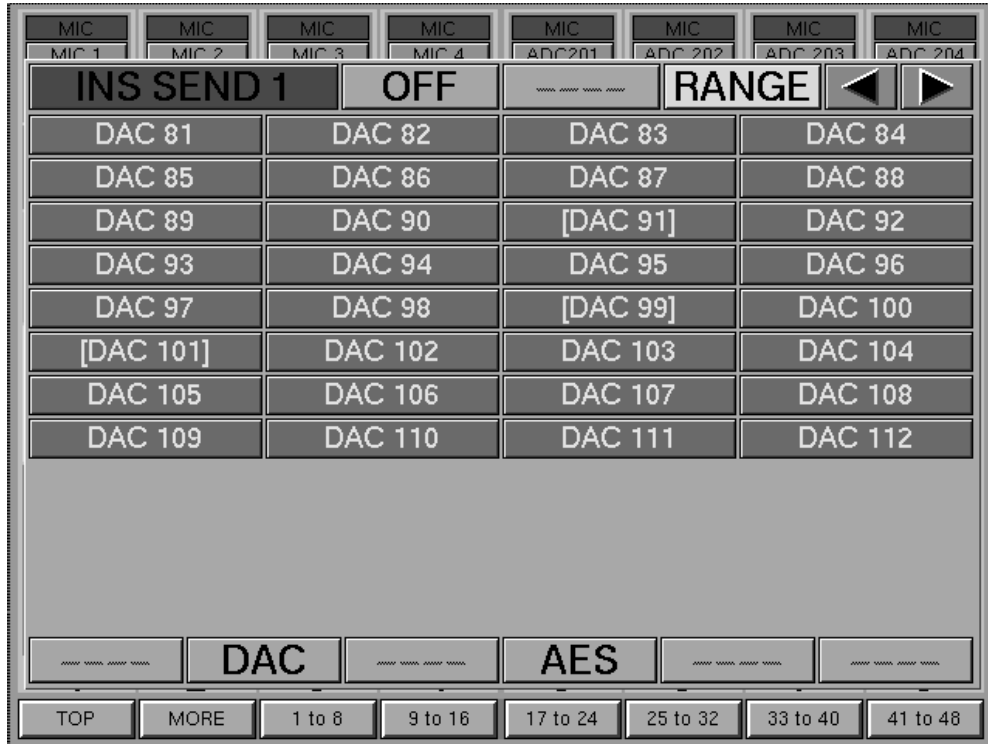

Figure A

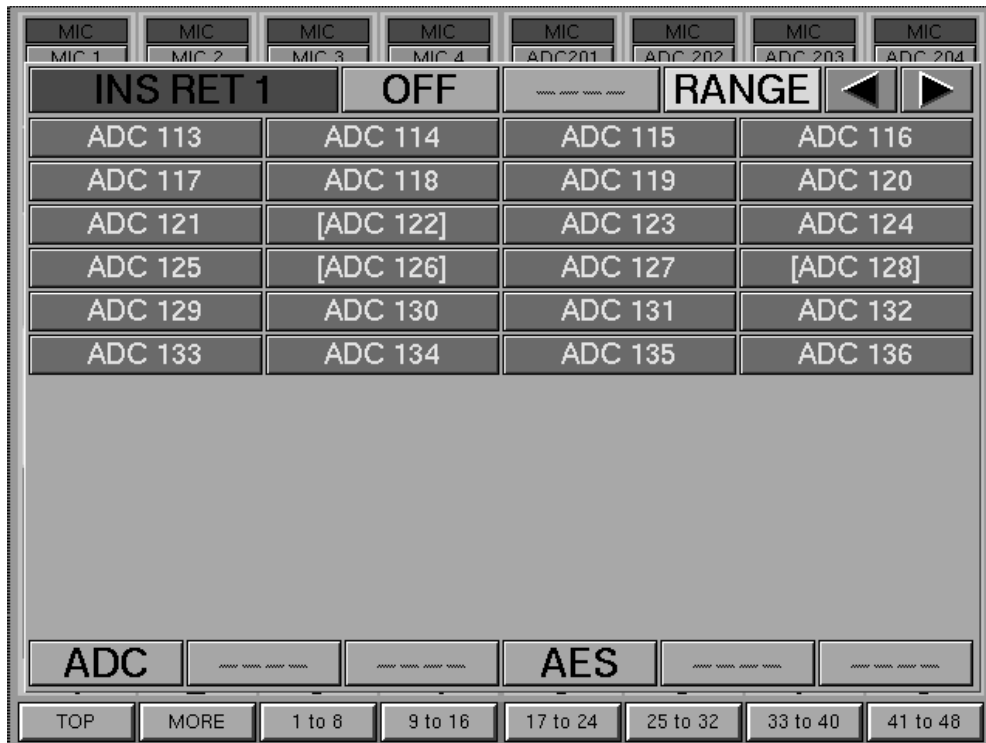

Figure B

CHANNEL INSERT pop-ups

MIC	MIC	MIC	MIC	MIC	MIC	MIC	MIC
MIC 1	MIC 2	MIC 3	MIC 4	ADC201	ADC 202	ADC 203	ADC 204
48V   LoZ	48V   LoZ	48V   LoZ	48V   HiZ	48V   HiZ	48V   HiZ	48V   HiZ	48V   HiZ
INS 1	New Entry						
INSERT	MT-INS	1960	1961				
DBX160	DBX165	DBX166	DBX902				
DBX120	PULTEC	SONYF7	TTCOMP				
APHEXL	APHEXR	GMLEQL	GMLEQR				
TUBE1A	TUBE1B	DS201L	DS201R				
BS402L	BS402R	BS502L	BS502R				
BS901	A&D760	DL221	FRCHLD				
KT 60	KT 360	SUMTLA	SUM EQ				
1176 1	1176 2	DRM500	ORB EQ				
LA2A	KEPEX2	db 740	FOC EQ				
1	2	3	4	5	6	7	8
TOP	MORE	1 to 8	9 to 16	17 to 24	25 to 32	33 to 40	41 to 48

Figure C

## CHANNEL INSERT pop-up

**NAME – Fifth field**

Click on the fifth (lowest) field to name the device inserted. This name appears in an 8-character display in the Input Channel & Inserts panel when the Insert function is selected. A pop-up appears as in Figure C. Click on a suitable name already in the list or select NEW ENTRY and use the QWERTY keyboard to type in a new name of up to 8 characters. Press ENTER when finished.

# 5-2 Channel Screens



Figure A - M/T GROUP FAST INSERT

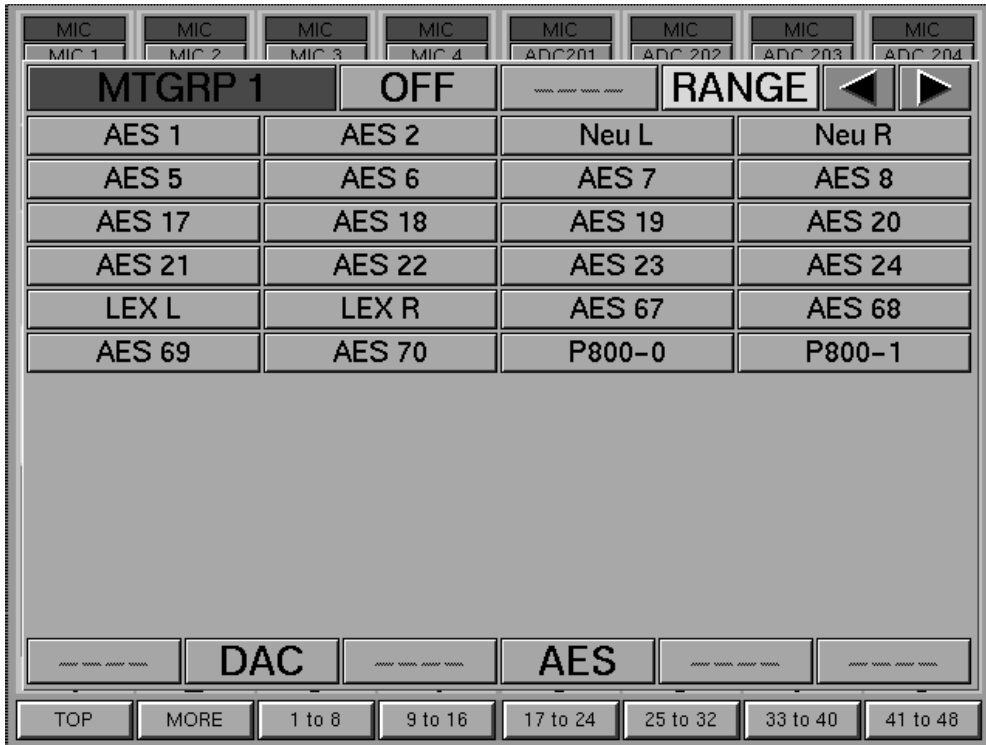

Figure B - M/T GROUP OUTPUT

M/T GROUP pop-ups

## Assigning M/T GROUP INSERTS and OUTPUTS

The 8 blocks at the bottom of the GUI entitled M/T GRP, each with 7 clickable fields (including the title) are used to set up the multitrack outputs and inserts.

### FAST INSERT – Upper field

Clicking on the upper M/T GRP field gives access to the FAST INSERTS pop-up. Each selection can have a pre-assigned input, output and appropriate name. These are set up via the PREF (Preferences) GUI described later in this chapter.

Click on the desired device name in the pop-up and its input and output will be connected simultaneously. The I/O device names will be displayed in the fourth and fifth fields and the actual device name will be displayed in the seventh and lowest scribble field. The name will also be displayed in the Insert section of the MULTITRACK Panel in the dot character display.

Once actioned as a Fast Insert, the assignments to the other fields can be edited or set up on an individual basis as described later.

#### Note:

*The M/T GROUP OUTPUTS are always fed to MADI loops 1 and 2 but further parallel assignments can be made as follows:*

### GROUP OUTPUT – Second field

The second field is used to select the destination for the M/T Group outputs. Click on this for the pop-up displaying possible destinations. Figure A shows analogue destinations (DACs). Click on the desired DAC number to assign a Send. For a digital output, click on AES for the list of digital destinations. Further pages of related pop-ups can be accessed by clicking on ◀ or ▶. Click on OFF to disable an output.

### RANGE

A contiguous range of M/T Group outputs can be assigned simultaneously. To assign a set of consecutive groups to a number of consecutive outputs, channel M/T Groups 1-4 feeding DACs 5-8 as an example:

- Click on the second field of Channel 1 for the assignment pop-up shown in Figure B.
- Click on RANGE and its characters turn white and the background red.
- Click on the lowest number of the DACs required, 5 in this example, and it highlights red.
- Click on the highest number of the DACs required, 8 in this example, and DACs 5-8 are assigned simultaneously to M/T Group Sends 1-4.

### GROUP O/P WORD LENGTH – Third field left

The third field allows the M/T Group output word length to be set, if the send is digital. Click on it to cycle through the word lengths 16 bit, 20 bit and 24 bits.

#### Note:

*The word length for the MADI output is set at the central Monitor Panel.*

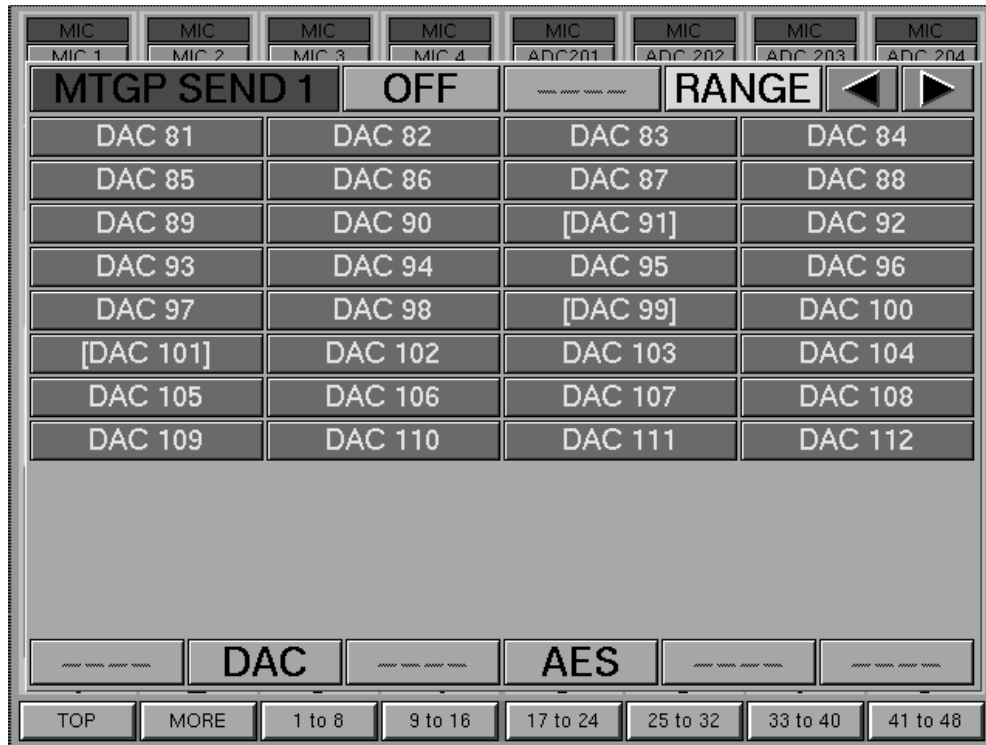

Figure C - INSERT SEND

M/T GROUP pop-up

### GROUP O/P SAMPLE RATE CONVERTER – Third field right

This indicator turns red and reads “ON” when a digital I/O that has an SRC turned on is selected. SRCs are controlled via the PREFERENCES GUI, described later in this chapter.

### INSERT SEND – Fourth field

The fourth field is used to select the M/T Group insert send destination or adjust an assignment set using the Fast Insert function. Click on this to display a pop-up as shown in Figure C. Click on the desired analogue send destination or click on AES for the digital send destination. Further pages of related pop-ups can be accessed by clicking on ◀ or ▶. Click on OFF to disable an insert send. Click on RANGE to set a contiguous set of M/T Group Insert Sends as described for the second field in this section.

### INSERT RETURN – Fifth field

The fifth field is used to select the M/T Group insert returns. Click on this to display a pop-up. Click on the desired analogue return source or range.

### WORD LENGTH – Sixth field left

The sixth field allows the M/T Group insert send and return word length to be set, if the insert device is digital. Click on it to cycle through the word lengths 16 bit, 20 bit and 24 bits. It will be set for both send and return simultaneously.

---

### **INSERT SAMPLE RATE CONVERTER – Sixth field right**

This indicator turns red and reads “ON” when a digital I/O that has an SRC turned on is selected. SRCs are controlled via the PREFERENCES GUI, described later in this chapter.

### **NAME – Seventh field**

The seventh field is used to enter an electronic scribble name for the insert. Click on this to display a pop-up. Either click on a name already in the list or select NEW ENTRY and use the QWERTY keyboard to type in a new name of up to 8 characters. Press ENTER when finished.





### 5-2-3 Equaliser & Filters GUI

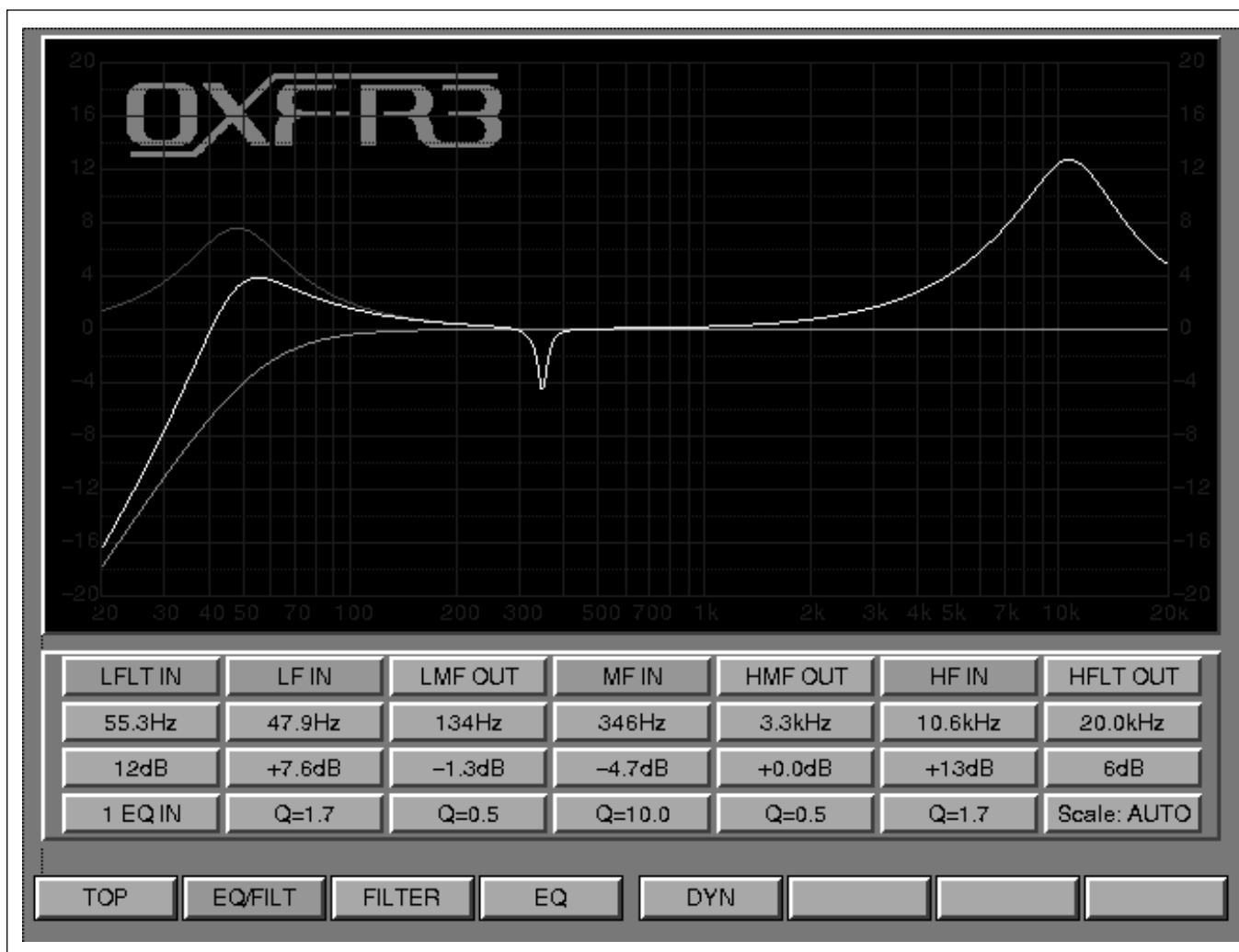

EQUALISER & FILTERS GUI layout

This GUI displays the 5 Band Equaliser, High and Low Filter curves as a combination (default) or individually. The parameters for each section are also indicated.

#### Viewing EQ and Filter curves (Press softkeys below the LCD screen)

- **EQ/FILT** - The combination of EQ and Filters is displayed in White.  
- Red line = EQ contribution; Green = Filters contribution.
- **FILTER** - Combined HF and LF Filters response curve only.
- **EQ** - Equaliser response curve only.

To view the individual contribution of any particular band, click on its name field e.g. MF IN. The colour coded individual curve will be displayed along with the combined response. Click **EQ** to release.

The vertical scale for boost and cut can be set using the ▲ and ▼ keys below the screen. The scale options are: +/-2.5dB, +/-5dB, +/-10dB, +/-15dB, +/-20dB, +/-40dB, +/-100dB and AUTO which is the default.

## 5-2-4 Dynamics GUI

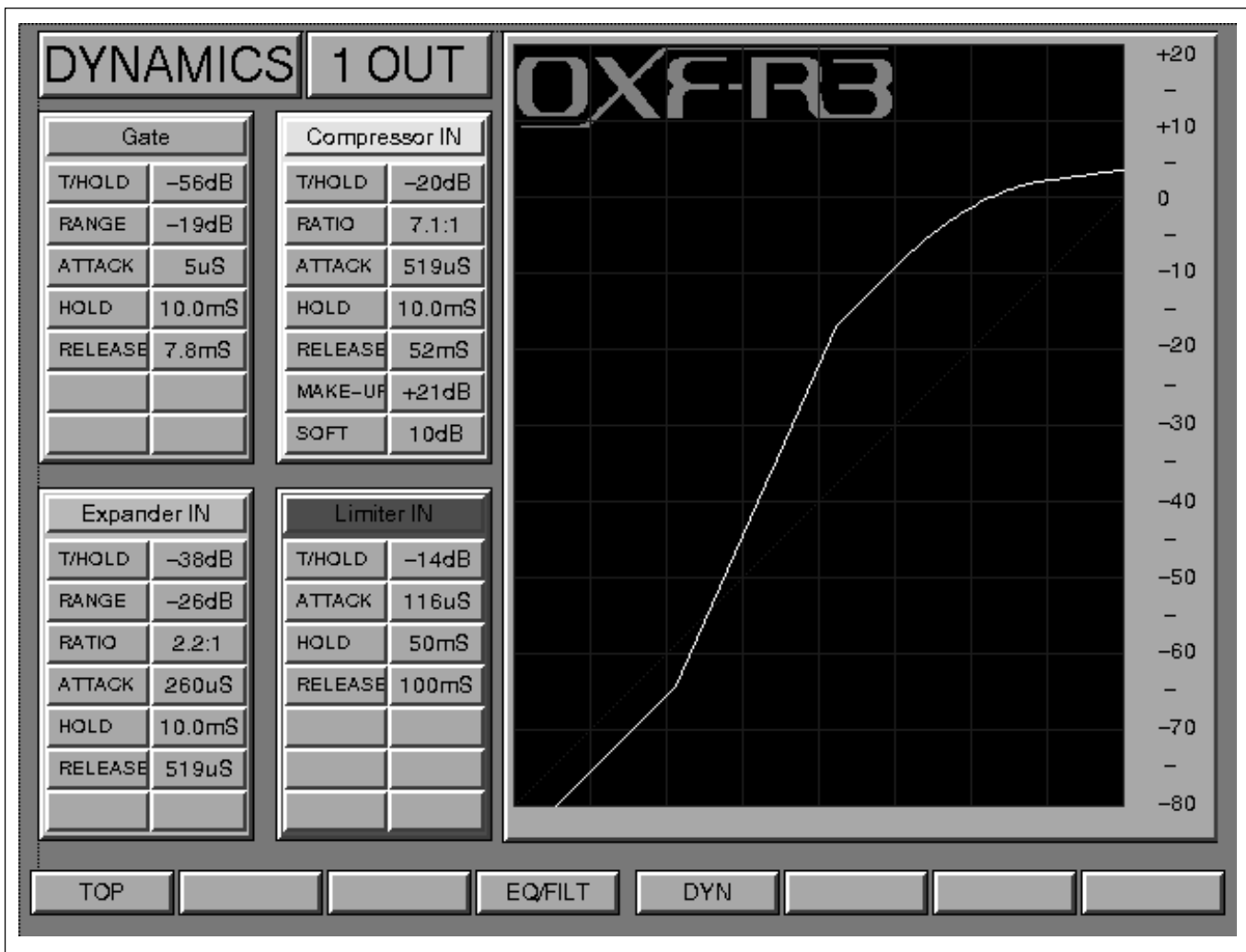

DYNAMICS GUI layout

This GUI functions in a similar manner to the Equaliser & Filters screen, displaying the knob setting parameters for the Gate, Expander, Compressor and Limiter simultaneously. The related dynamics transfer curve is displayed for the channel currently accessed.

In the graph displayed on this screen, the X axis has a range of -80dB (left) to 0dB (right, full scale) for the input scale. The Y axis represents output scale from -80dB to +20dB. The output scale is expanded to +20dB at the top end to allow for any gain make-up to be displayed.

### 5-2-5 Preferences GUI

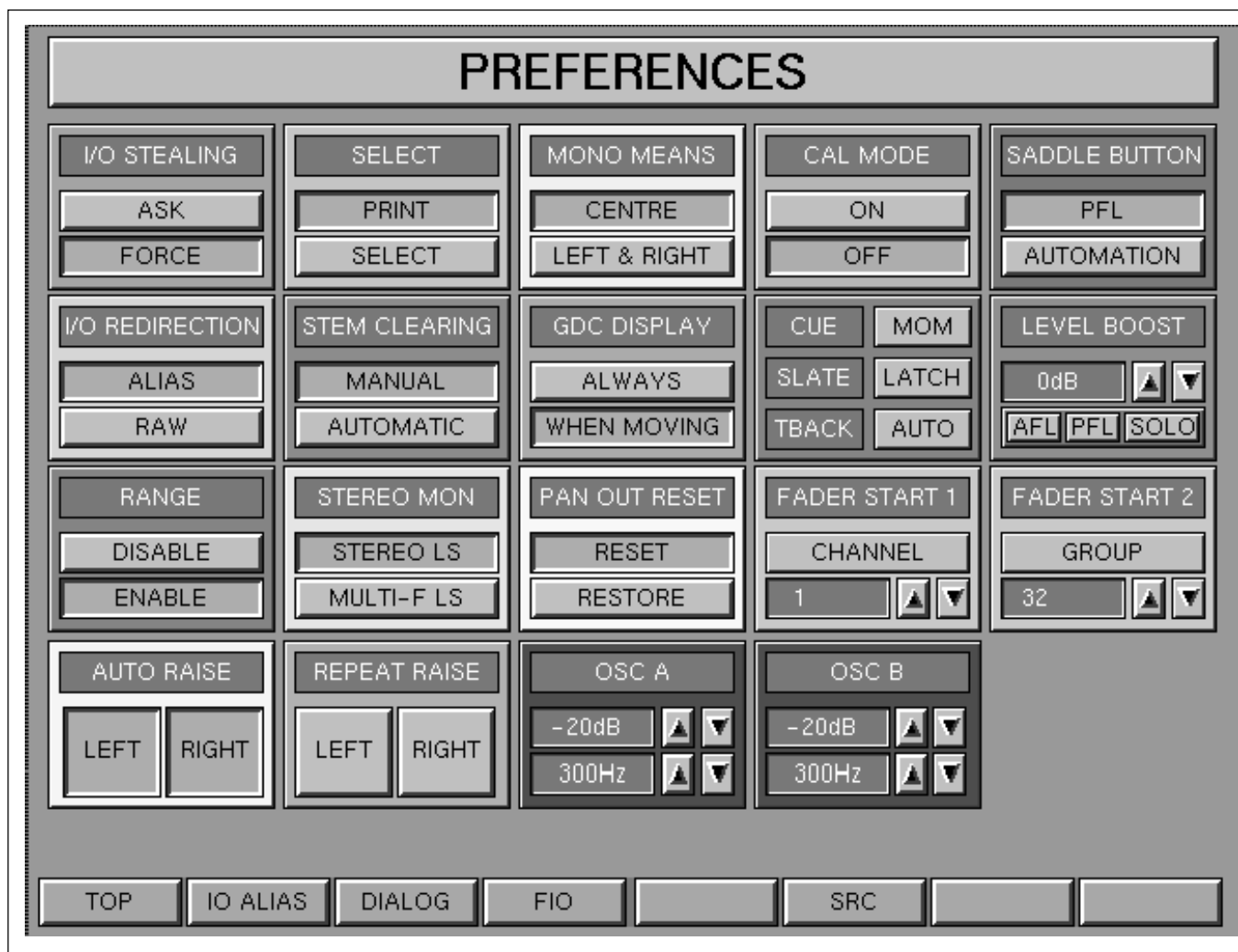

PREFERENCES GUI layout

#### General

Click on Preference options according to the following descriptions:

#### I/O STEALING

- **ASK** - A warning dialogue will appear when re-assigning I/O already in use, allowing the previous assignment to be retained.
- **FORCE** - I/O can be re-assigned without dialogue, irrespective of other assignments.

#### Note:

*The warning will never appear when the RANGE function is used. I/O will be assigned whether in use or not, without notification.*

## SELECT

Allows a one-shot print function of Mixer GUIs, such as I/O set-ups, using the SELECT buttons below the LCD screens in the channel sections.

- **PRINT** - Click on PRINT. Then, pressing SELECT below any LCD in the channels sections will cause an image of the GUI displayed to be printed, provided that the cursor is already in that screen. The selector then reverts to the normal SELECT function. PRINT must be clicked on again to print a second or further GUI.
- **SELECT** - Default function setting for the SELECT buttons below the LCD screens in the channel sections.

### Note:

*This print output function requires the system to be configured with a Postscript compatible printer.*

## MONO MEANS

Sets the destination LS when, for a mono signal, **MONO** is selected at the Monitor panel.

- **CENTRE** - Mono signal fed to the Centre LS.
- **LEFT & RIGHT** - Mono signal fed to both the Left and Right LS.

## CAL MODE

Relates to the Surround LS Calibration settings for mixing to picture.

- **ON** - LS1 Monitor Outputs use their calibration settings.
- **OFF** - LS1 Monitor Outputs default to uncalibrated settings.

## SADDLE BUTTON

Option to allow the buttons in the middle of the Fader Knobs to be used for two different functions:

- **PFL** - Momentary PFL operation.
- **AUTOMATION** - Fader Automation drop-in to record fader moves.

## I/O REDIRECTION

- **RAW** - The 'raw' names such as ADC 1 are displayed for I/O legends.
- **ALIAS** - The specified 'alias' names, such as MIC 1, are displayed for I/O legends.

## STEM CLEARING

- **MANUAL** - Channel to stem routing is totally flexible allowing routing to multiple stems. Routing selections must be cleared manually.
- **AUTOMATIC** - Channel to stem routing selections for a particular Stem will be cleared automatically if another stem is selected. In other words, channels can route only to a single stem.

### GDC DISPLAY (Global Delay Compensation)

Option to set what is displayed in the 8 character dot display above the Global Display Compensation knob on the Free Assign Area & Dynamics panel.

- **ALWAYS** - Units of delay are indicated continuously.
- **WHEN MOVING** - GLOB DEL displayed until the knob is moved, when the units of delay are indicated, and remains for 3 seconds after release of the knob.

### MODES for COMMUNICATIONS BUTTONS

There are three button modes for each of CUE, SLATE and TBACK as below. Click on the buttons to the right of these labels accordingly.

- **MOM(entary)** - Press and hold.
- **LATCH(ing)** - Press for on and press again for off.
- **AUTO** - Combination mode: Press and hold for a momentary function, or short press to latch and another short press to release.

### LEVEL BOOST

Click on AFL, PFL or SOLO and then click on the ▲ and ▼ buttons to adjust monitor level beyond the default unity gain.

- **AFL** - Allows boost of up to 20dB in 1dB steps.
- **PFL** - Allows boost of up to 20dB in 1dB steps.
- **SOLO** - Allows boost of up to 20dB in 1dB steps.

### RANGE

- **DISABLE** - Disables the Range function.
- **ENABLE** - Allows consecutive numbered sections of I/O devices, of the same type, to be assigned to consecutive numbered sets of channels when using the I/O GUI.

### STEREO MON

- **STEREO LS** - Stereo monitor signals will be heard on the normal Stereo Monitor LS.
- **MULTI-F LS** - Stereo monitor signals which include Stereo External Sources, AFL, PFL, MAIN and MONO (Mono of Main Output Bus) will be heard on the L and R Surround Monitor LS.

### PAN OUT RESET

- **RESET** - Switching a Pan out will centre it if switched in again.
- **RESTORE** - Switching a Pan out will centre but it will resume its previous setting if switched in again.

### FADER STARTS 1 & 2

Two GPIO relay closure Fader Starts can be assigned to Channel or Control Group Faders.

- **Upper Button** - Click on to cycle through CHANNEL and GROUP Faders or OFF.
- **▲ ▼ Buttons** - Click to select the Channel or Group Fader number.

**AUTO RAISE**

- **LEFT** - EQ & Dynamics GUIs are automatically displayed in the left channels section, above respective panels, when any EQ or Dynamics controls are adjusted.
- **RIGHT** - EQ & Dynamics GUIs are automatically displayed in the right channels section, above respective panels, when any EQ or Dynamics controls are adjusted.

**REPEAT RAISE**

When assigning I/O, clicking on the source or destination device normally causes the pop-up to close. With the use of Repeat Raise, the pop-up remains open and increments the channel number for the same input or output for a further assignment and so on. Click on the red title bar at the top left when completed.

- **LEFT** - Repeat Raise operates for the left side of the console.
- **RIGHT** - Repeat Raise operates for the right side of the console.

**OSC A & OSC B**

Oscillators outputs A & B are controlled by clicking on ▲ and ▼ to the right of the parameter displays.

- **Level: dBs** - -100, -90, -80, -70, -60, -50, -40, -30 – 0dB in 1dB steps.
- **Frequency: Hz** - 20, 30, 40, 50, 60, 70, 80, 90, 100, 200, 300, 400, 500, 600, 700, 800, 900.  
**kHz** - 1, 2, 3, 4, 5, 6, 7, 8, 9, 10, 12, 14, 16, and 20.

**The Softkeys for this GUI:**

- **TOP** - Selects the top level LOGO screen
- **IO ALIAS** - Alias naming facility for all types of I/O
- **DIALOG** - Naming facility for all I/O Scribble pop-ups
- **FIO MONO** - Set-up facility for Fast Insert I/O
- **SRC** - Sample Rate Converter control

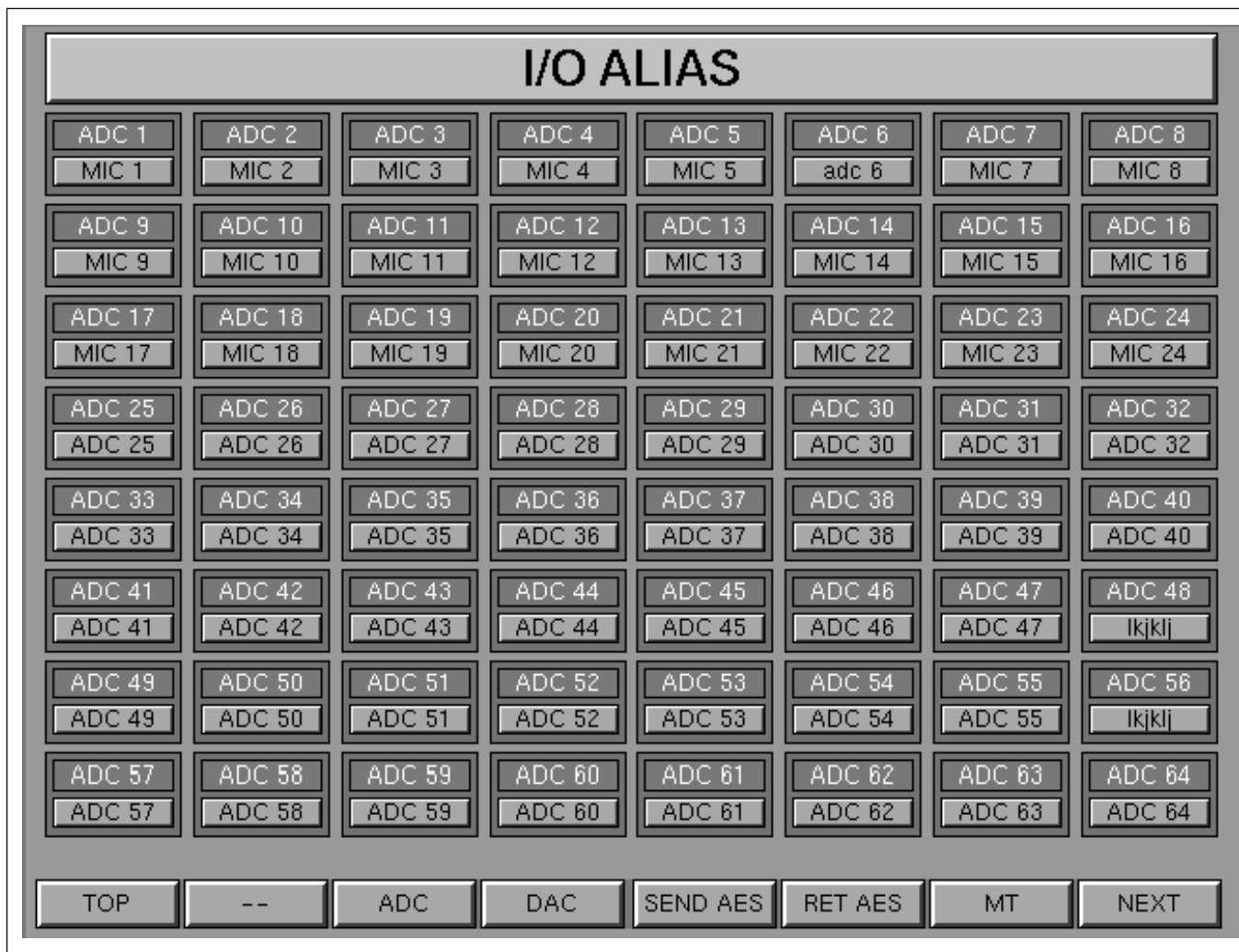

PREFERENCES GUI - I/O ALIAS page layout

### General

This GUI allows I/O objects to be given names which can relate to the local environment. ADC 1 could be named MIC 1, for example, which might relate to a particular microphone input socket on a panel in the studio. So instead of ADC 1 appearing in the I/O assignment GUI, MIC 1 will be displayed, provided 'Alias' is selected in the PREFERENCES GUI.

### NAME – Lower field

Click on this to display a pop-up. Enter a name of up to 6 characters using the QWERTY keyboard. Press ENTER when finished.

### The Softkeys for this GUI:

- TOP - Selects the top level LOGO screen
- ADC - Alias names for ADCs
- DAC - Alias names for DACs
- SEND AES - Alias names for AES I/O Outputs
- RET AES - Alias names for AES I/O Inputs
- MT - Alias names for MADI Multitrack Returns
- NEXT - Further pages of ADCs, DACs, AES & MADI I/O

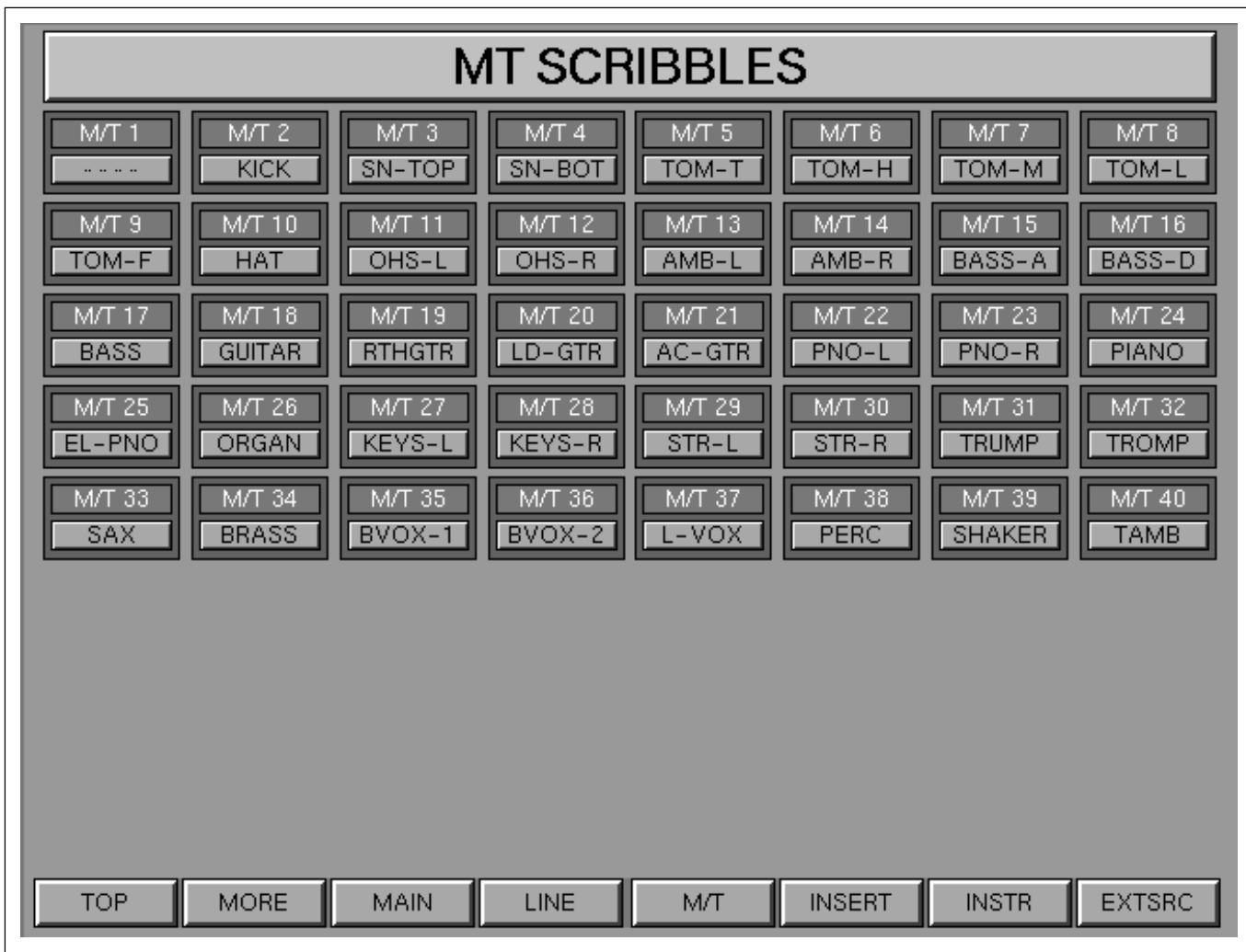

PREFERENCES GUI - MULTITRACK SCRIBBLES page layout (Select 'DIALOG' at the PREFERENCES GUI)

### General

The majority of I/O assignments can have names associated with them which may be displayed on GUIs and electronic scribbles. This GUI allows customisation of the scribble name pop-ups allowing frequently used pre-set names to be listed and edited.

### NAME – Lower field

Click on this to display a pop-up. Enter a name of up to 6 characters using the QWERTY keyboard. Press ENTER when finished.

### The Softkeys for this GUI:

- TOP - Selects the top level LOGO screen
- MORE - Further page for naming scribbles (MIDI, TRACK & GROUP)
- MAIN - Main Output names (SSGs, Sends etc) pop-up
- LINE - Line Inputs names pop-up
- M/T - Multitrack Return Inputs names pop-up
- INSERT - Insert names pop-up
- INSTR - Instrument names pop-up (MIC Inputs)
- EXTSRC - External Source names pop-up



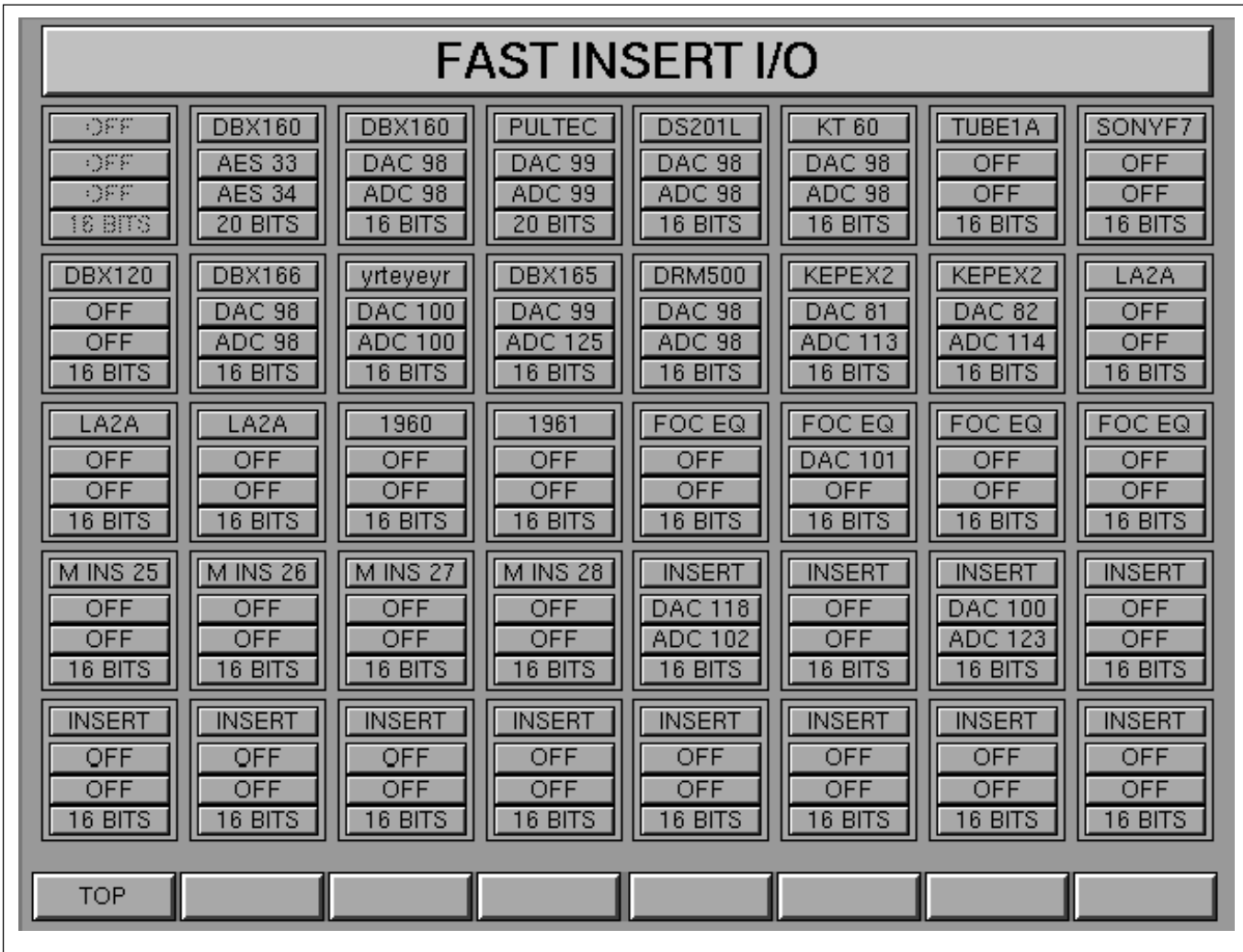

PREFERENCES GUI - FAST INSERT I/O set-up page layout

**General**

This GUI allows the setting up of Send I/O, Return I/O and Electronic Scribble names for devices used via Channel Inserts. The preset FAST INSERTs are accessed via the channel I/O GUI.

**Setting up FAST INSERT I/O**

Each of the 40 blocks in the GUI has 4 clickable fields as follows:

**Note:**

*The following description applies to Mono Inserts. Stereo Inserts have an additional field since there are left and right audio paths.*

**NAME – Upper field**

Click on the upper field for a pop-up to name the insert device to be assigned. This name will appear in an 8-character display at the Input Channel & Inserts panel when the Insert function is selected. Click on a suitable name already in the list or select NEW ENTRY and use the QWERTY keyboard to type in a new name of up to 8 characters. Press ENTER when finished.

### **INSERT SEND – Second field**

The second field is used to specify an I/O destination for the selected Insert Send. Click on this for a pop-up displaying possible destinations. Click on the desired DAC to assign an analogue Send or, for a digital output, click on AES for the digital destinations. Further pages of related pop-ups can be accessed by clicking on Prev. or Next. Click on OFF to disable a Send.

### **INSERT RETURN – Third field**

The third field is used to select the I/O Insert Return source for the channel. Click on this for a pop-up displaying possible return sources. Click on the desired ADC for an analogue return source or click on AES for the digital return sources. Further pages of related pop-ups can be accessed by clicking on ◀ or ▶. Click on OFF to disable a Return.

### **WORD LENGTH – Fourth field**

The fourth (lowest) field allows the insert Send and Return word length to be set, if the insert device is digital. Click on it to cycle through the word lengths 16 bit, 20 bit and 24 bits. It will be set for both send and return simultaneously.

**Note:**

*Although the word length field is operable when analogue I/O is selected, it only affects digital I/O.*

### **The Softkeys for this GUI:**

- **TOP** - Selects the top level LOGO screen

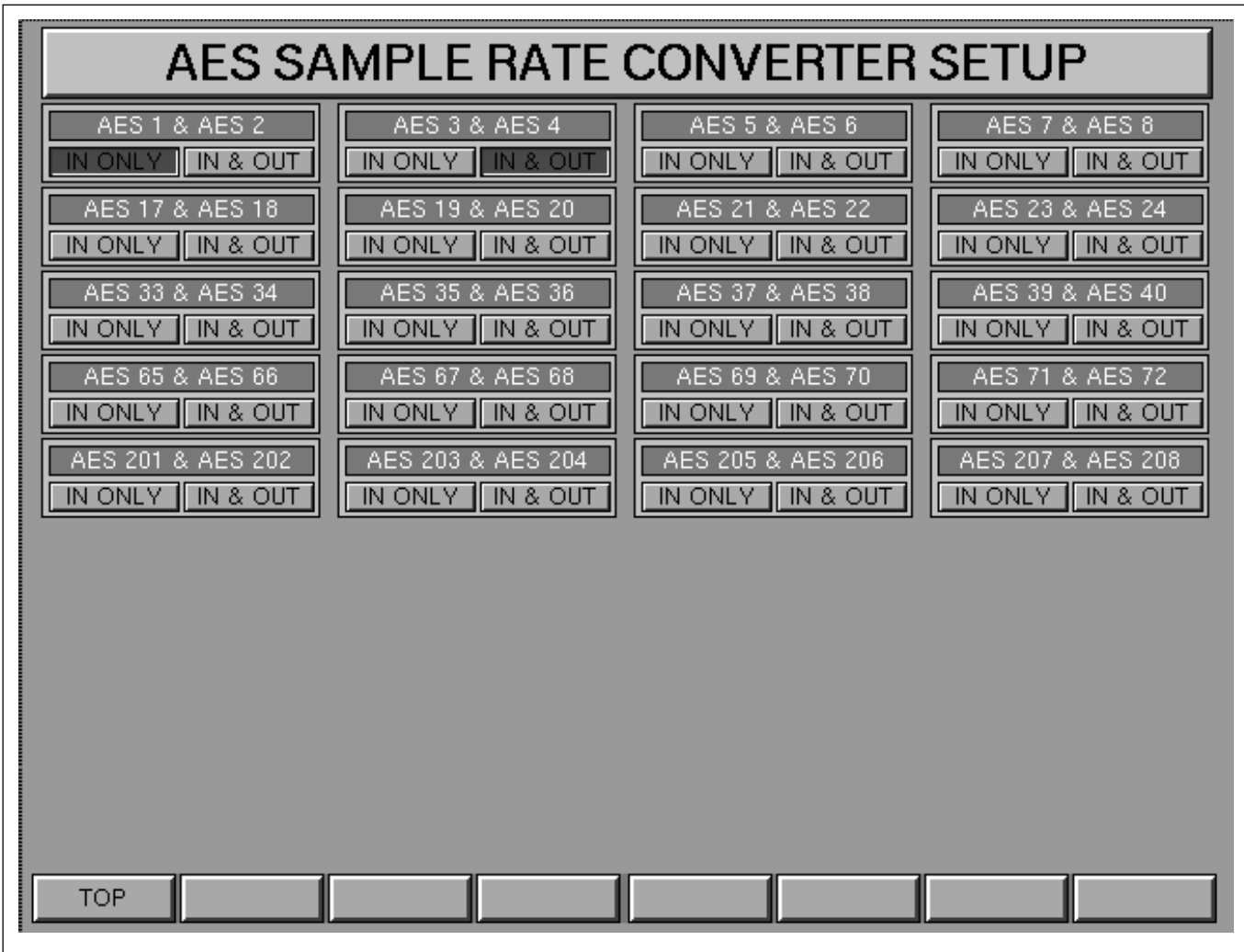

AES SAMPLE RATE CONVERTER SETUP GUI

**General**

This GUI allows Sample Rate Converters (SRCs) to be switched in and out on AES Digital I/O.

SRCs are switchable in odd/even pairs only for:

- **INPUTS**
- **INPUTS & OUTPUTS**

**Note:**

*It is not possible to select an SRC to an Output alone. This because a clock signal must be extracted from a source outside of the system and this is acquired from AES inputs.*

**The Softkeys for this GUI:**

- **TOP** - Selects the top level LOGO screen

## 5-2-6 MASTER GUI

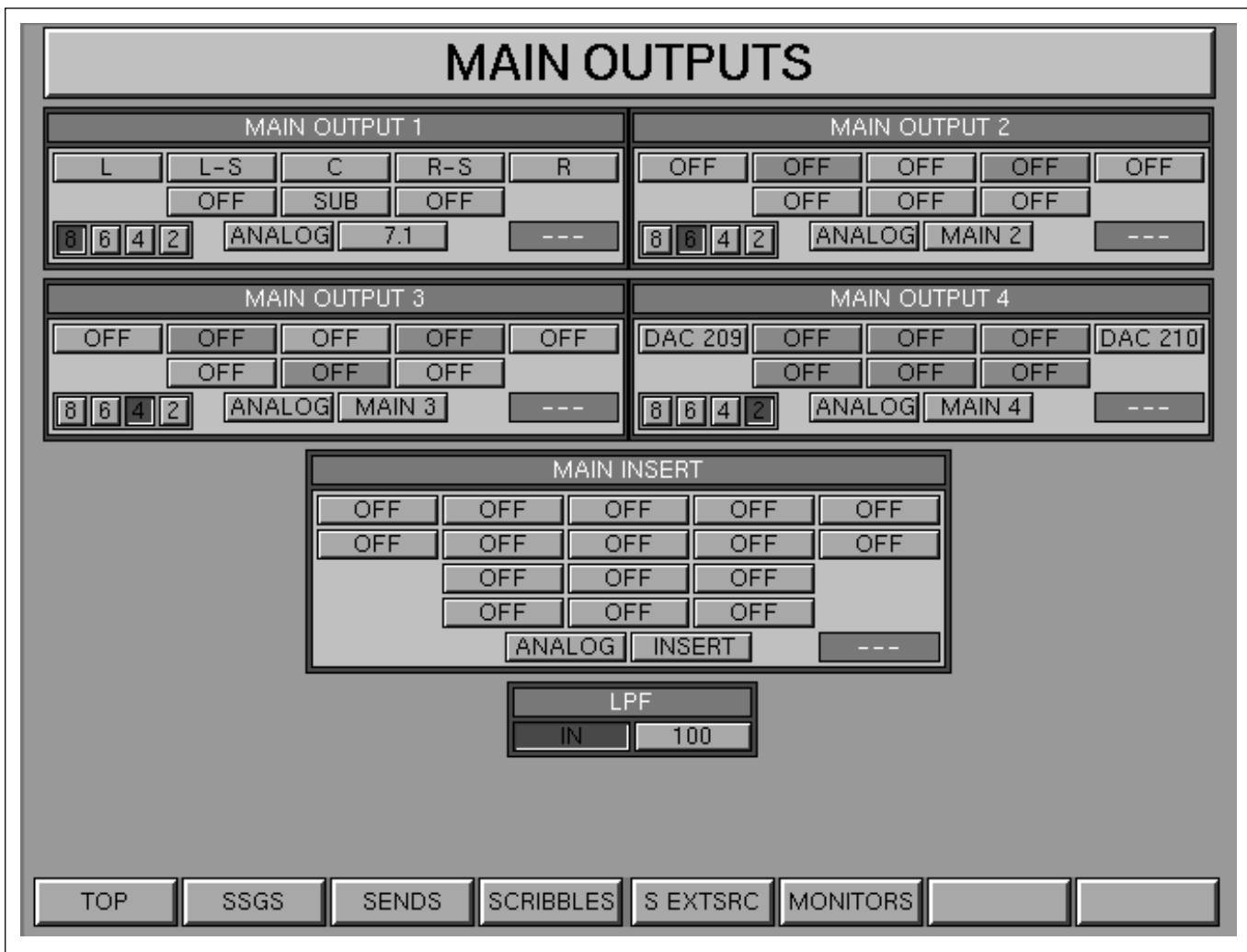

MASTER GUI layout

### This GUI allows assignment of:

- MAIN OUTPUT BUS (4 separate outputs)
- MAIN BUS INSERTs

### General

The MAIN OUTPUTS GUI allows assignments of all master bus outputs, their inserts and external monitor inputs etc. A number of pages can be accessed using softkeys at the bottom of the screen.

### The Softkeys for this GUI:

- TOP - Selects the top level LOGO screen
- SSGS - Super Send Group Outputs & Inserts
- SENDS - Send Outputs
- SCRIBBLES - Control Group & Talkback Scribbles
- S EXTSRC - Stereo & Multi-Channel External Sources
- MONITORS - Control Room Monitors, Studio LS, F/back, T/back & Oscillators

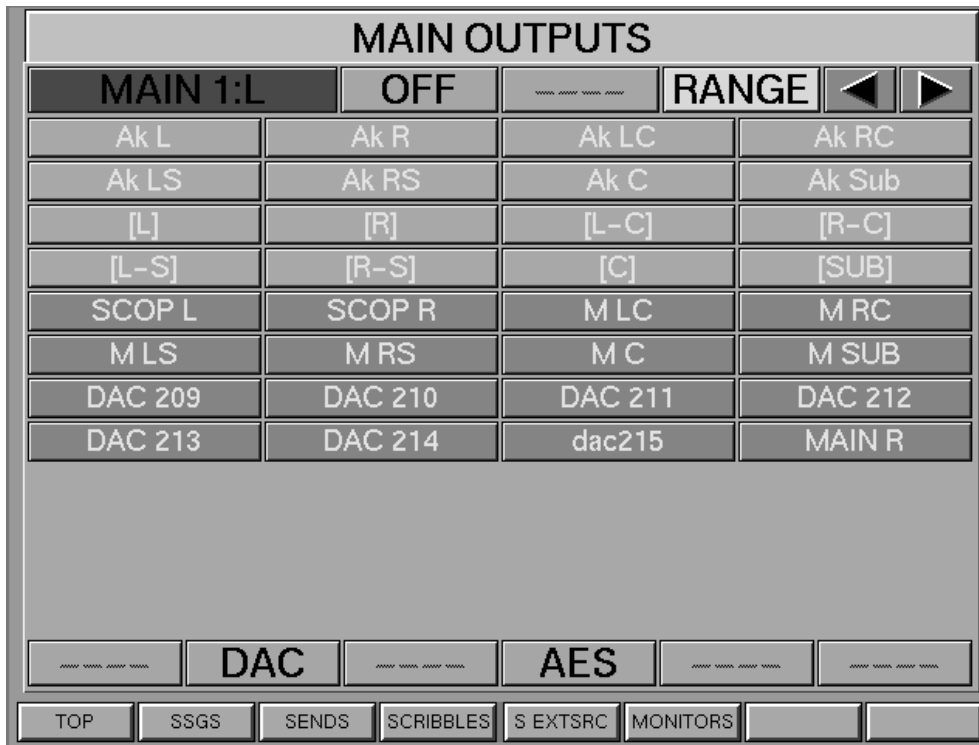

Figure A

### MASTER GUI - MAIN OUTPUT BUS output pop-up

**Note:**

Whilst the following describes selecting destinations and inserts for the MAIN BUS, the methods of operation apply to all pages related to the MASTER GUI.

**General**

The clickable fields in the Main Output GUI are laid out in the form of a set of Surround LS. The upper section contains a single set of Inserts which affect all four outputs.

**OUTPUT FORMAT – MAIN OUTPUT 1 upper section**

The 8 fields labelled  –  allow the selection of I/O destinations for the Main Output 1. 8 fields are displayed in the illustration, but the number displayed depends upon the current format for the Main Output Bus. Click on any of these fields to display the pop-up as shown in Figure A, which lists analogue outputs. Click on one of them to select it or click on AES for the list of digital destinations.

**OUTPUT FORMAT – MAIN OUTPUT 1 lower left**

The 4 buttons labelled , , , and  inter-cancel allowing the setting of the format for the output, 7.1, 5.1, LCRS or Stereo respectively. A Fold-down Matrix derives signals for formats with fewer outputs than the Main Bus.

**WORD LENGTH – MAIN OUTPUT 1 lower middle left**

This field is displaying ‘ANALOGUE’ in the illustration, since analogue

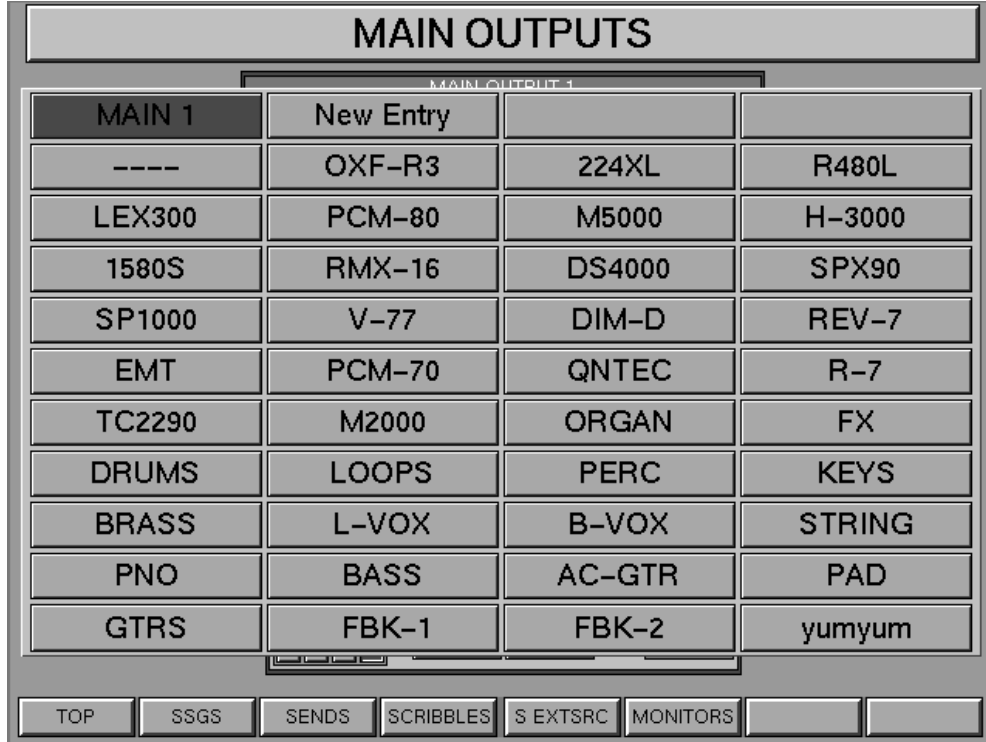

Figure B

#### MASTER GUI - MAIN OUTPUT BUS scribble pop-up

outputs have been selected. When digital outputs are set, the Word Length is displayed here. Clicking on it cycles through 16, 20 and 24 bit settings.

#### NAME – MAIN OUTPUT 1 lower middle right

Click on this to display a pop-up as shown in Figure B. Either click on a name already displayed or click on NEW ENTRY and use the QWERTY keyboard to type in a name of up to 8 characters. Press ENTER when finished.

#### SAMPLE RATE CONVERTER – MAIN OUTPUT 1 lower right

This indicator turns red and reads “SRC ON” when a digital source is selected which has its SRC turned on. SRCs are controlled via the PREFERENCES GUI, described earlier in this chapter.

#### MAIN OUTPUTS 2, 3 & 4

The assignment operations for MAIN OUTPUT 1 apply to 2, 3 and 4.

#### SUB FILTER – Lower middle block

High Pass Filter for the SUB output. Click on the lower left button to switch the filter section in and out of the signal path. Set the frequency with the button to the lower right, 70 or 100Hz. The slope is 24dB/Octave.

#### To assign an insert on the MAIN OUTPUT BUS

The Insert selectors are laid out in the form of a set of Surround LS in the section headed ‘MAININSERT’.

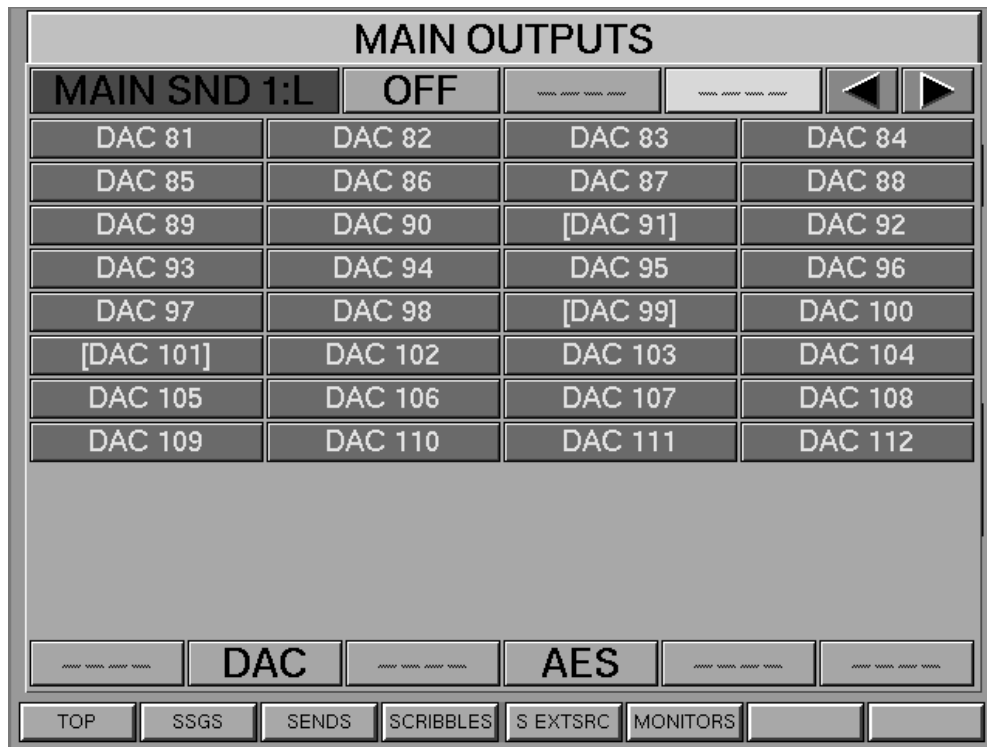

Figure C

### MASTER GUI - MAIN OUTPUT BUS insert pop-up

#### INSERT SEND – Upper field

Click on an upper field of one of the 8 blocks for the Insert Send pop-up displaying possible destinations. Figure C shows analogue destinations in the form of DAC outputs. Click on the desired DAC number to assign a Send. For a digital output, click on AES for the list of digital destinations. Click OFF to disable a Send.

#### INSERT RETURN – lower field

Click on a lower field of one of the 8 blocks for the Insert Return pop-up in order to display sources. Click on the desired analogue return source or click on AES for the digital return sources list.

#### WORD LENGTH – MAIN INSERT 1 lower middle left

When digital outputs are assigned, the Word Length is displayed here. Clicking on it cycles through 16, 20 and 24 bit settings.

#### NAME – MAIN INSERT 1 lower middle right

Click on this to display a pop-up. Either click on a name already in the list or select NEW ENTRY and use the QWERTY keyboard to type in a new name of up to 8 characters. Press ENTER when finished.

#### SAMPLE RATE CONVERTER – MAIN INSERT 1 lower right

This indicator turns red and reads “SRC ON” when digital I/O is selected which has its SRC turned on. SRCs are controlled via the PREFERENCES GUI, described earlier in this chapter.

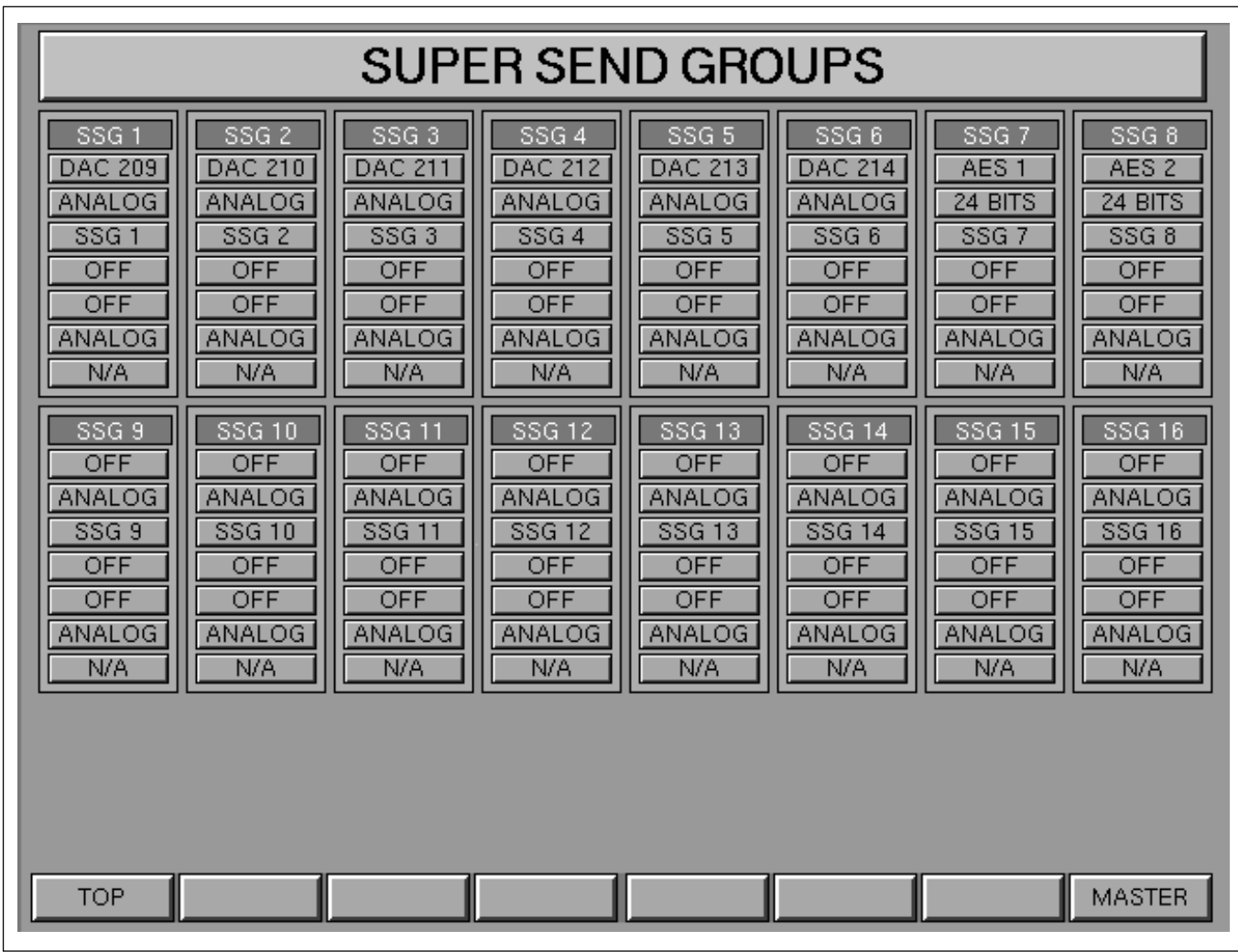

MASTER GUI - SUPER SEND GROUPS Outputs and Inserts page layout

**This GUI allows assignment of:**

- SUPER SEND GROUP Outputs 1-16
- SUPER SEND GROUPS 1-16 Inserts

**The Softkeys for this GUI:**

- TOP - Selects the top level LOGO screen
- MASTER - Selects the top level MASTER screen



## 5-2 Channel Screens

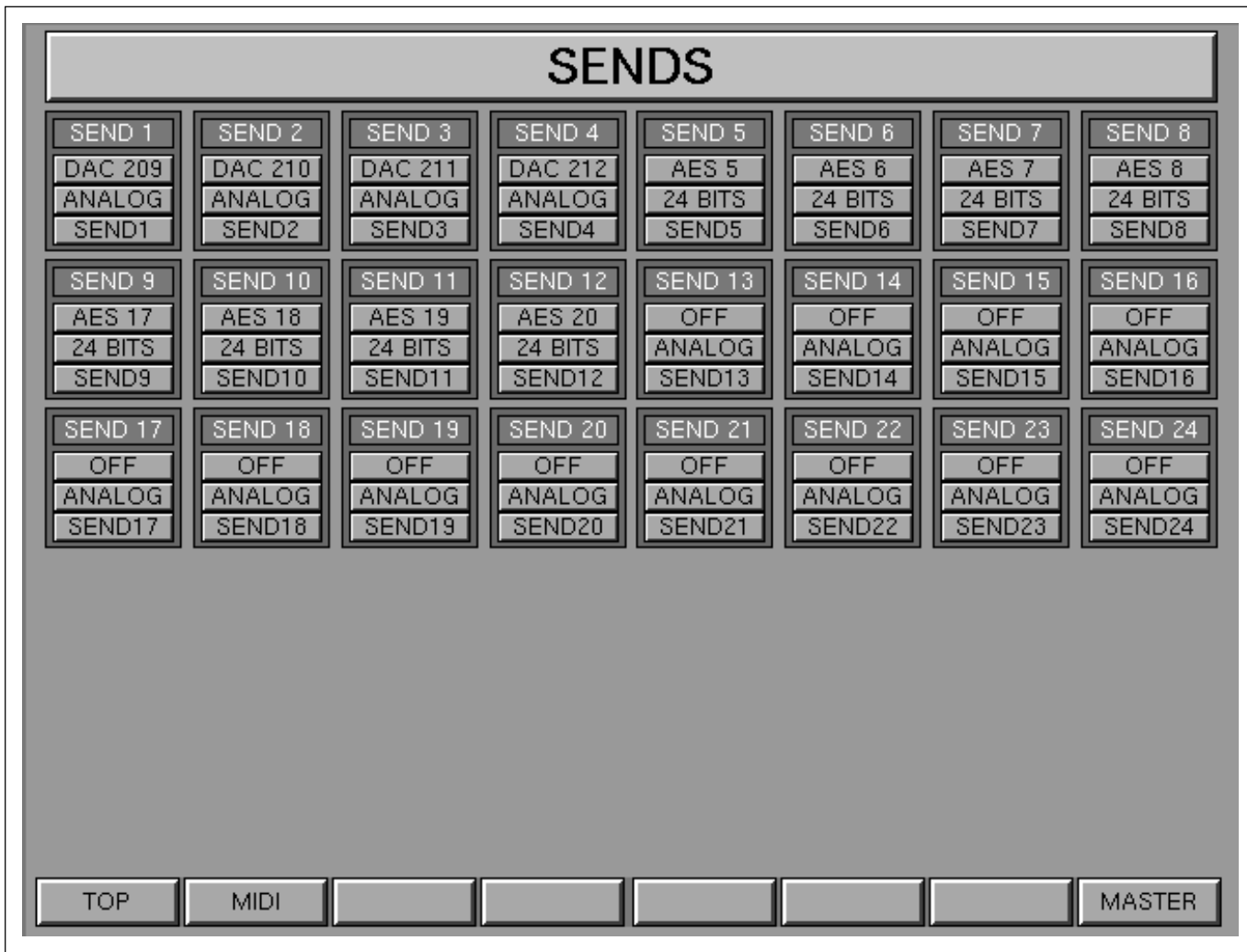

MASTER GUI - SEND OUTPUTS page layout

**This GUI allows assignment of:**

- SEND Bus Outputs 1-24
- MIDI Control Pages 1-24

**The Softkeys for this GUI:**

- TOP - Selects the top level LOGO screen
- MIDI - Selects the MIDI page with the same number as the currently accessed Send Output
- MASTER - Selects the top level MASTER screen

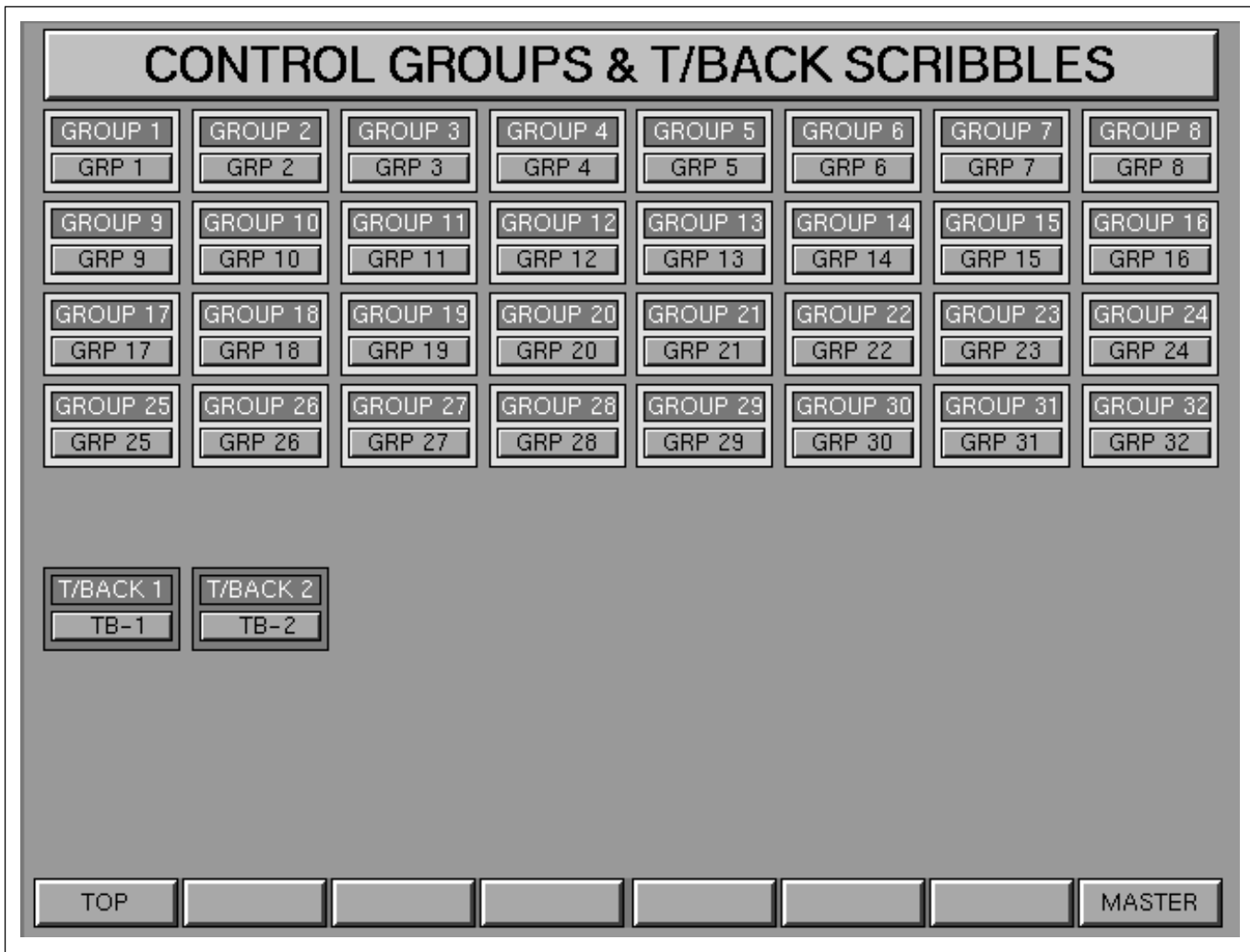

MASTER GUI SCRIBBLES - CONTROL GROUP & SCRIBBLES page layout

**This GUI allows scribble name assignment for:**

- CONTROL GROUP FADERS
- TALKBACK SCRIBBLES

**The Softkeys for this GUI:**

- TOP - Selects the top level LOGO screen
- MASTER - Selects the top level MASTER screen

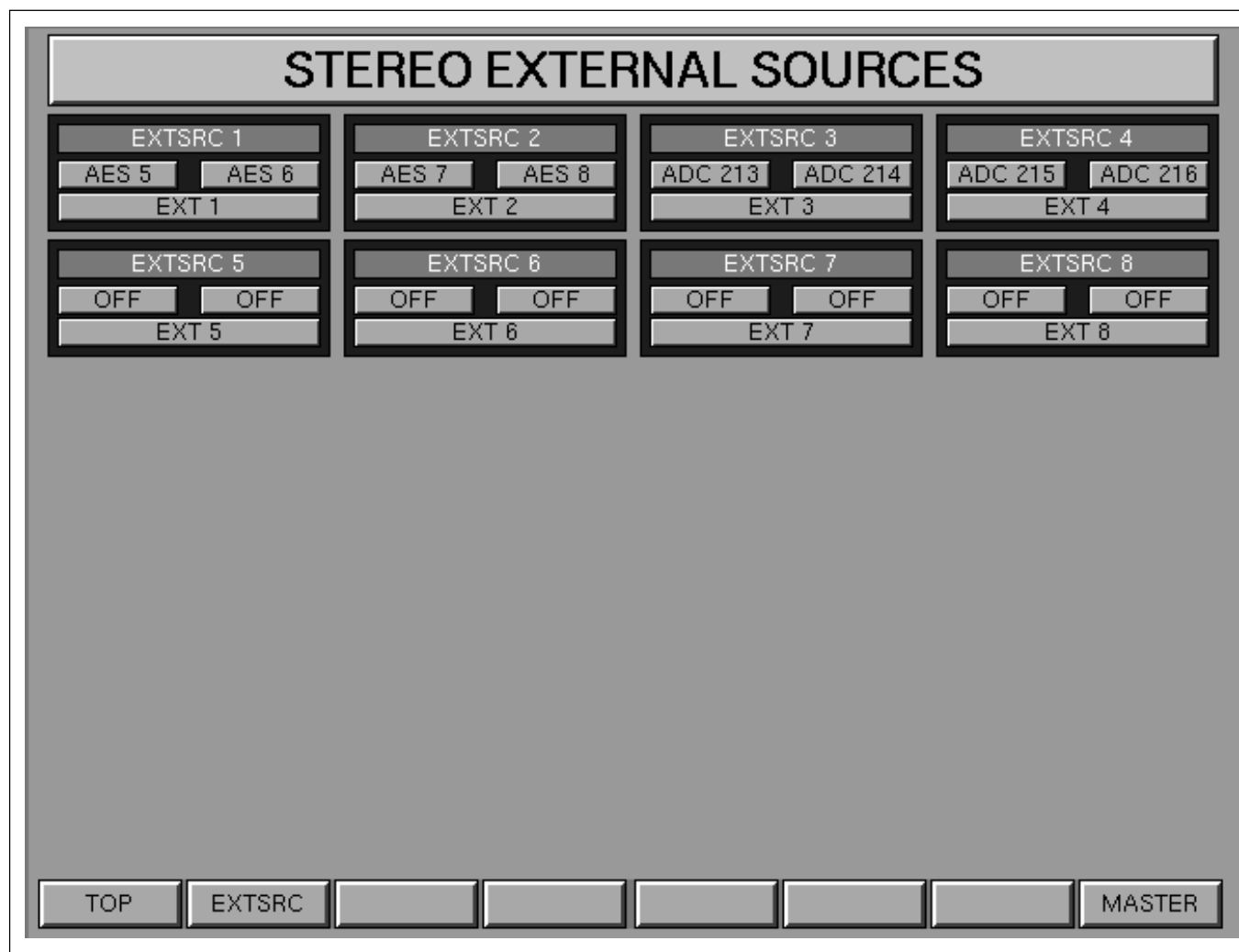

MASTER GUI - STEREO EXTERNAL SOURCES page layout

**This GUI allows assignment of:**

- **STEREO EXTERNAL SOURCES 1-8**  
(Select using the EXT SOURCE buttons in the Monitor Panel to listen to them)

**The Softkeys for this GUI:**

- **TOP** - Selects the top level LOGO screen
- **EXTSRC** - Selects Surround EXTERNAL SOURCES
- **MASTER** - Selects the top level MASTER screen

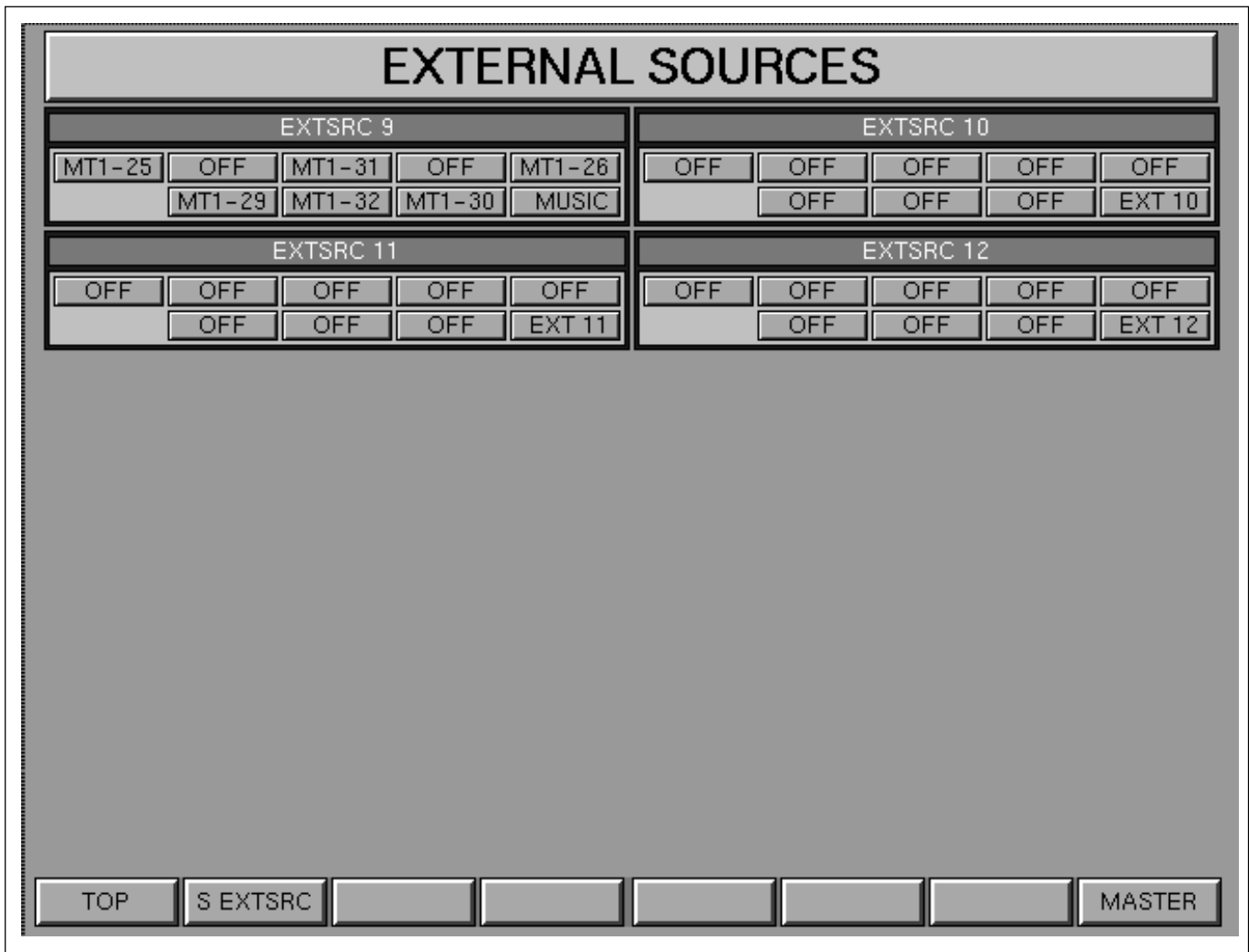

MASTER GUI - Surround EXTERNAL SOURCES page layout

**This GUI allows assignment of:**

- **MULTI-FORMAT EXTERNAL SOURCE Inputs 1-6**  
(Select using the EXT SOURCE buttons in the Monitor Panel to listen to them)

**The Softkeys for this GUI:**

- **TOP**            - Selects the top level LOGO screen
- **S EXTSRC**       - Selects STEREO EXTERNAL SOURCES
- **MASTER**        - Selects the top level MASTER screen

## 5-2 Channel Screens

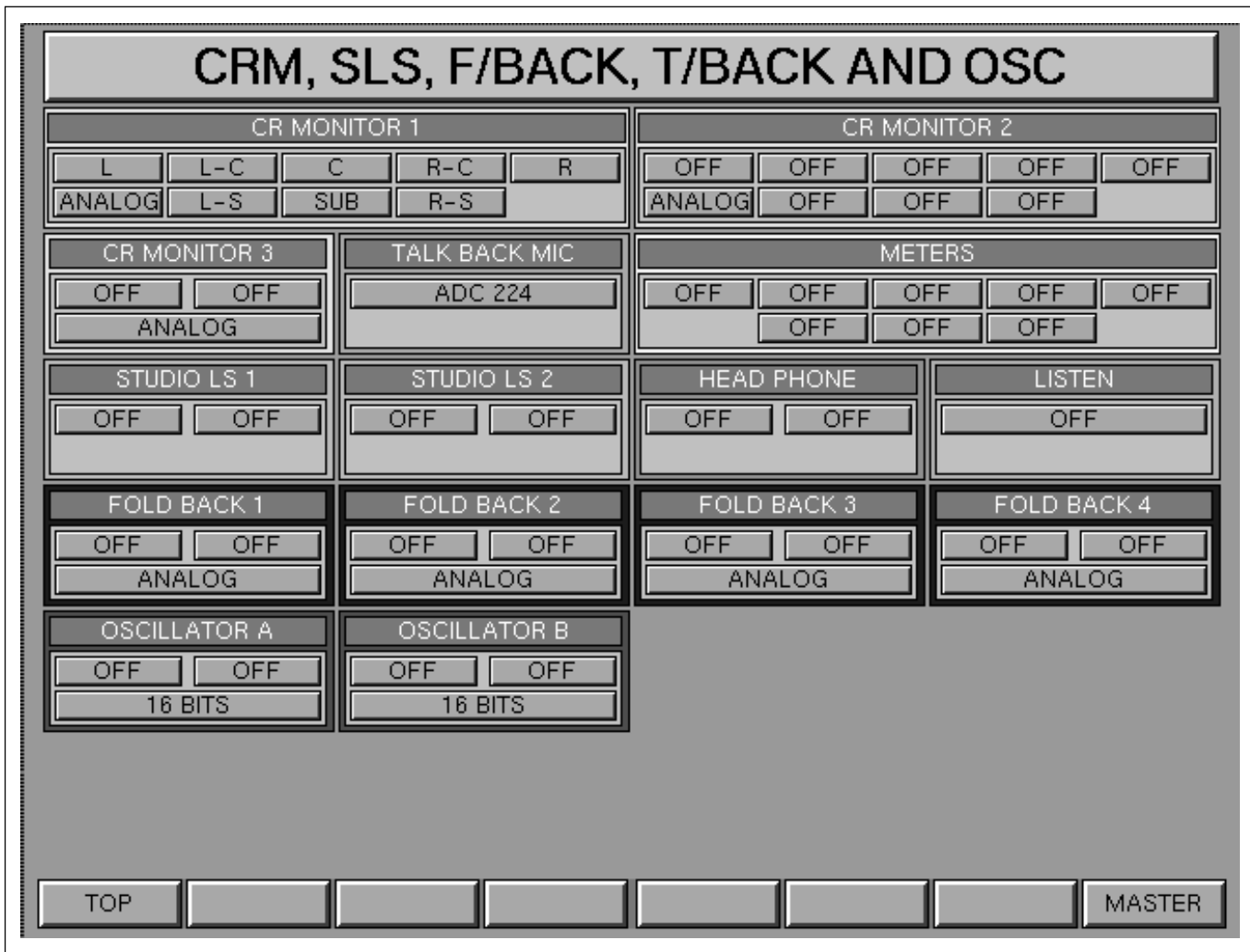

MASTER GUI - Monitors and misc. assignments page layout

### This GUI allows assignment of:

- CONTROL ROOM MONITOR LS Outputs 1, 2 & 3
- TALKBACK MIC
- METERS - Output for Signals Feeding Central Meters
- STUDIO LS Outputs 1 & 2
- HEADPHONE Output 1
- LISTEN Mic
- FOLDBACK Outputs 1-4
- OSCILLATOR A and B Outputs

### The Softkeys for this GUI:

- TOP - Selects the top level LOGO screen
- MASTER - Selects the top level MASTER screen