



## RRX100

Created for straight-up durability, the RRX100, is one tough cookie. A rugged mixer case, the RRX100 is built to fit the Denon DNX 100 Mixer. Designed with brawn and brains it includes a front access door for easy access to your mixer controls. Smart, Simple and 100% Road Ready!

### Rugged Road Ready Features

- \* Beefy, Stackable Ball Corners
- \* Double Anchor Industrial Rivets
- \* Recessed, Industrial Grade Latches
- \* Recessed, Spring Loaded Handles
- \* Industrial Grade Rubber Feet
- \* Premium 3/8" Vinyl Laminated Plywood
- \* Tongue and Groove Locking Fit
- \* ATA 300 Rating
- \* Road Ready Limited Lifetime Warranty

Shipping Dimensions (inch): 13.1" x 16.7" x 10.4"

Shipping Weight (lbs): 15.8 lbs

Product Dimensions (inch): 11.5" x 15.7" x 9"

Product Weight (lbs): 14.1 lbs

Shipping Dimensions (cm): 33.5 x 42.5 x 26.5

Shipping Weight (kg): 7.2 kg

Product Dimensions (cm): 29.3 x 40 x 23

Product Weight (kg): 6.4 kg

3/05

### CASE FOR DENON DNX 100 MIXER

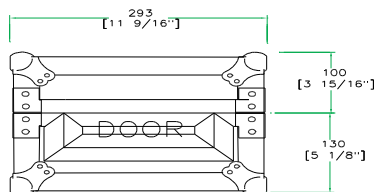

FRONT VIEW

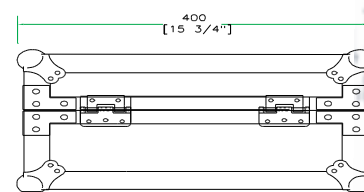

LEFT VIEW

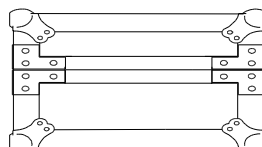

BACK VIEW

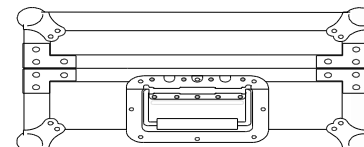

RIGHT VIEW

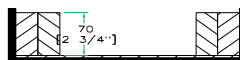

A-A VIEW

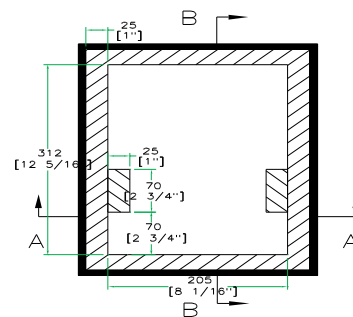

TOP VIEW OF COVER

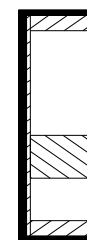

B-B VIEW

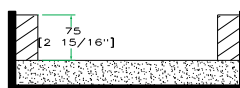

C-C VIEW

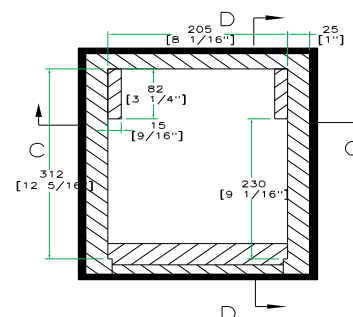

TOP VIEW OF BASE

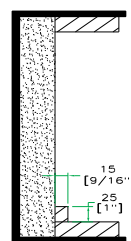

D-D VIEW

[www.roadreadycases.com](http://www.roadreadycases.com)

Road Ready Cases 18120 S. Broadway St. Unit B Gardena, Ca. 90248- 3536  
ph: 310 767 1772 fax: 310 767 1798