



# RRVE320DHC

Created for the Pro's, the RRVE320DHC, is made for the journey and built to hold strong in high stress situations. Designed to fit the Midas Venice 320 mixing board, the RRVE320DHC features a heavy-duty latchable, removable cover with our No-pressure design to protect your mixer controls and a unique low-profile base design that allows you to access you mixer's controls with ease. We also included a doghouse so you could get a grip on all your connections and threw in a rugged 3 1/2" caster for easy mobility.

## Rugged Road Ready

### Features

- \* Heavy Duty Industrial Grade Ball Corners
- \* Double Anchor Industrial Rivets
- \* Recessed, Industrial Grade Latches
- \* Recessed, Industrial Grade Handles
- \* Industrial Grade Rubber Feet
- \* Premium 3/8" Vinyl Laminated Plywood
- \* Tongue and Groove Locking Fit
- \* Low Profile Base
- \* Rugged 3 1/2" Caster
- \* Dog House
- \* ATA 300 Rating
- \* Road Ready Limited Lifetime Warranty

Shipping Dimensions (inch): 39.4 x 36.4 x 11.8

Shipping Weight (lbs): 74.4

Product Dimensions (inch): 38.7 x 35.9 x 11

Product Weight (lbs): 64.7

Shipping Dimensions (cm): 100 x 92.5 x 30

Shipping Weight (kg): 33.8

Product Dimensions (cm): 98.4 x 91.2 x 28

Product Weight (kg): 29.4

5/05

## MIDAS VENICE 320 MIXING BOARD CASE WITH DOGHOUSE AND CASTERS

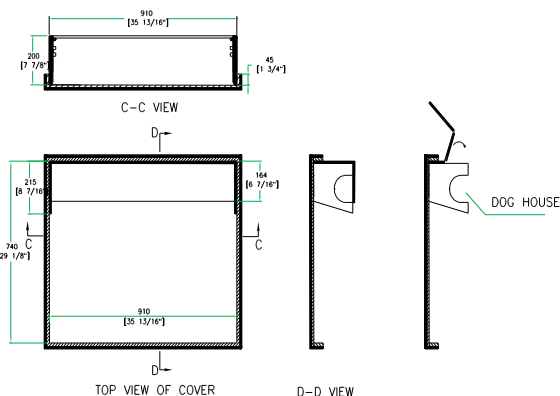
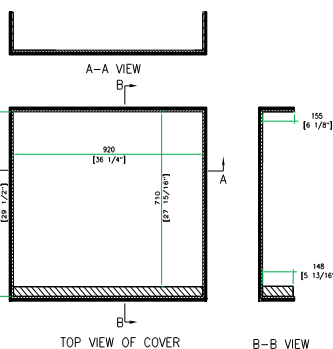
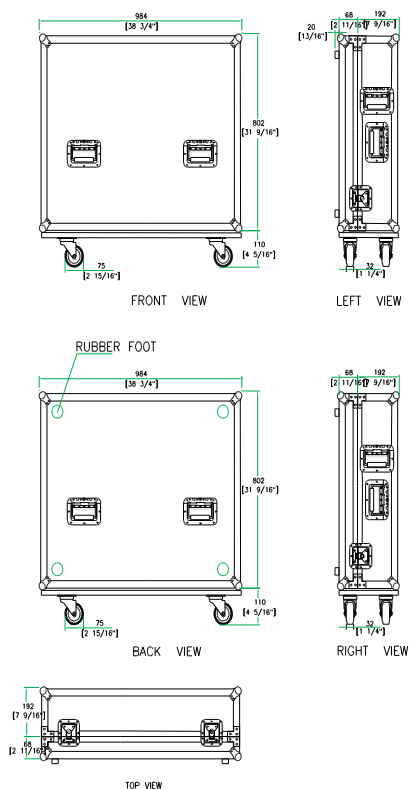

[www.roadreadycases.com](http://www.roadreadycases.com)

Road Ready Cases 18120 S. Broadway St. Unit B Gardena, Ca. 90248- 3536  
 ph: 310 767 1772 fax: 310 767 1798