



RRMG16E

Created for the Pro's, the RRMG16E mixer case is made for the journey and built to hold strong in high stress situations. Designed to fit the Yamaha MG 16/4 FX and MG 16/6 FX mixer, the RRMG16E features a heavy-duty removable, latchable cover with our No Pressure Design to protect your mixer controls and a unique low profile base design that allows you to access your mixers rear connection panel without removing your mixer from the case. Tougher than the pavement! That's the idea.

Rugged Road Ready Features

- * Double Anchor Industrial Rivets
- * Recessed, Industrial Grade Latches
- * Recessed, Spring Loaded Handles
- * Industrial Grade Rubber Feet
- * Premium Vinyl Laminated Plywood
- * Tongue and Groove Locking Fit
- * Low Profile Base Design
- * Road Ready Limited Lifetime Warranty

Shipping Dimensions (inch): 22 x 20.1 x 7.1

Shipping Weight (lbs): 16 lbs

Product Dimensions (inch): 21.4 x 19.4 x 6.3

Product Weight (lbs): 13.2 lbs

Shipping Dimensions (cm): 56x 51 x 18

Shipping Weight (kg): 7.3 kg

Product Dimensions (cm): 54.5 x 49.4 x 16

Product Weight (kg): 6 kg

5/05

CASE FOR YAMAHA MG 16/4 & MG 16/6FX MIXERS

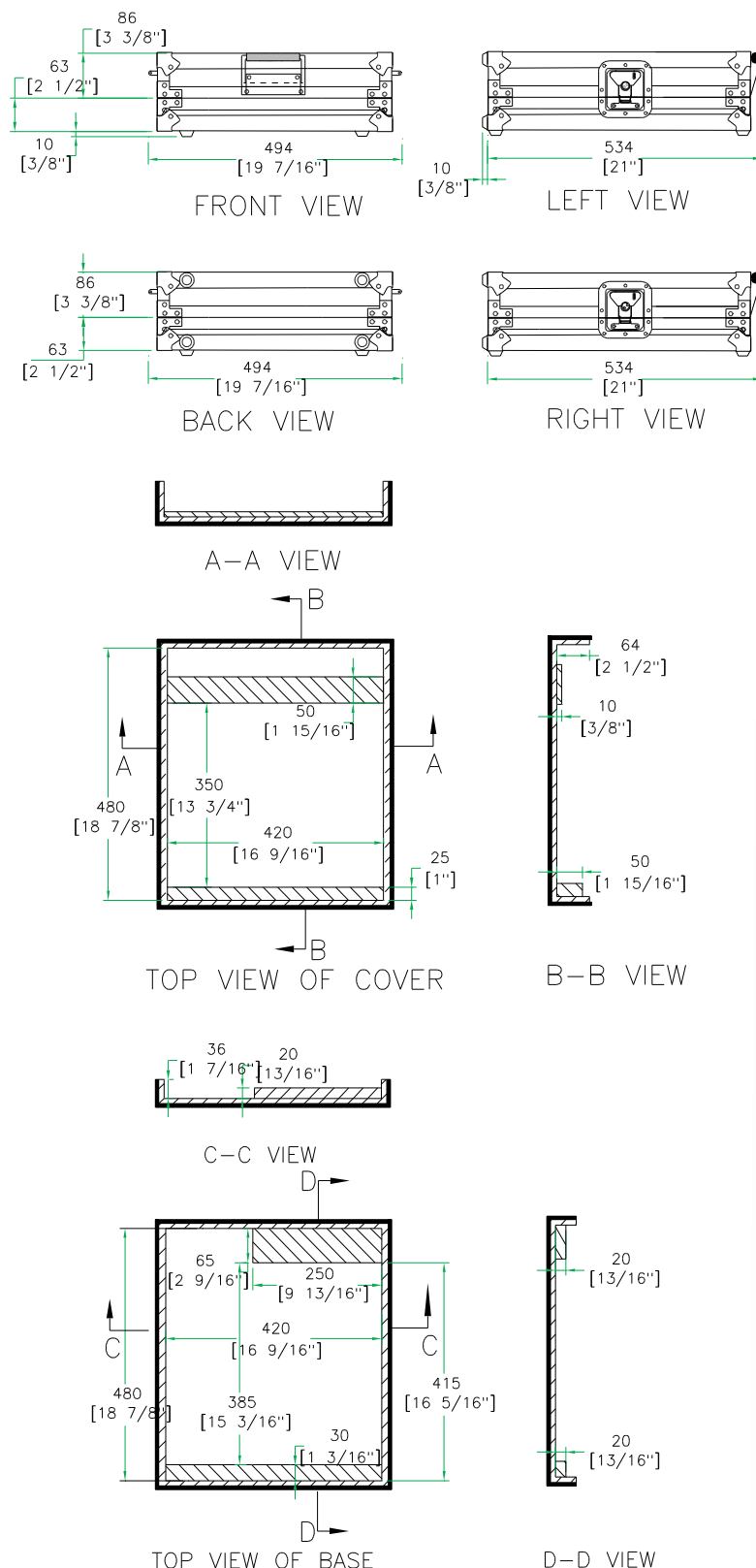

www.roadreadycases.com

Road Ready Cases 18120 S. Broadway St. Unit B Gardena, Ca. 90248- 3536
 ph: 310 767 1772 fax: 310 767 1798