



RRM2U

Good construction doesn't go out of style. That's our MO and that's why we create cases that are done right. Designed with a 10U slanted top rack for convenient mixer/CD controller placement and a 2U vertical rack for amp or effect units, the RRM2U is built right. The RRM2U features an 18" mountable rack depth and 2 heavy-duty removable covers. To make a good thing even better we added a unique removable, rear hinged door for easy access to your gear. At last, connections without a hassle.

Rugged Road Ready Features

- * Beefy, Stackable Ball Corners
- * Double Anchor Industrial Rivets
- * Recessed, Industrial Grade Latches
- * Recessed, Spring Loaded Handles
- * Industrial Grade Rubber Feet
- * Premium 3/8" Vinyl Laminated Plywood
- * Tongue and Groove Locking Fit
- * Heavy Duty Rack Rails
- * Hinged Rear Door
- * Mounting Hardware Included
- * ATA 300 Rating
- * Road Ready Limited Lifetime Warranty

Shipping Dimensions (inch): 24.2 x 21.9 x 15.9

Shipping Weight (lbs): 40.9

Product Dimensions (inch): 23.9 x 21.5 x 15.4

Product Weight (lbs): 37

Shipping Dimensions (cm): 61.5x 55.5 x40.5

Shipping Weight (kg):18.6

Product Dimensions (cm): 60.8 x 54.5 x 39

Product Weight (kg): 16.8

5/05

10U SLANT MIXER RACK 2U VERTICAL RACK SYSTEM

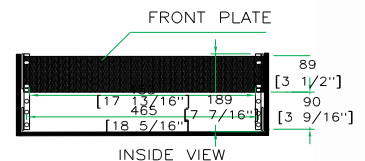
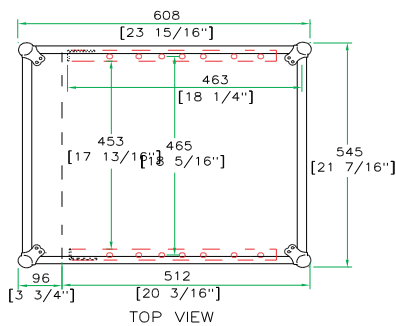
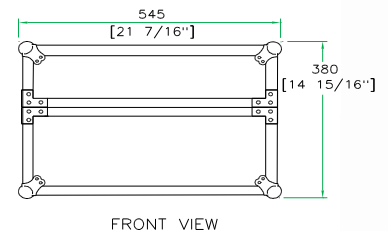
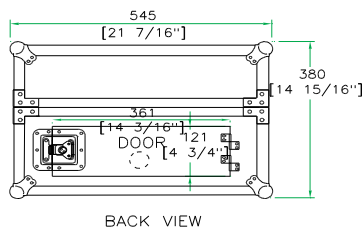
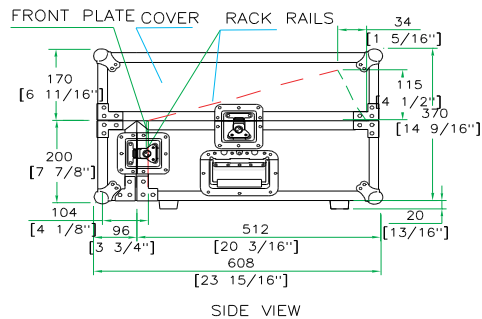

Need optional Road Ready Accessories to help outfit your Slant Rack? Check out our Road Ready Caster Kit (RRWAD) , Rolling Base with Storage Drawer (RR6WD)

www.roadreadycases.com

Road Ready Cases 18120 S. Broadway St. Unit B Gardena, Ca. 90248- 3536
ph: 310 767 1772 fax: 310 767 1798