



RRM244

Created for the Pro's, the RRM244 mixer case is made for the journey and built to hold strong in high stress situations. Designed to fit the Mackie SR 24.4 Pro mixer, the RRM244 features a heavy-duty, removable, latchable cover for easy access to your gear and our unique low profile base design that allows you to access your mixer's rear connection panel without removing your mixer from the case. Tougher than the pavement! That's the idea.

Rugged Road Ready Features

- * Heavy Duty Industrial Grade Ball Corners
- * Double Anchor Industrial Rivets
- * Recessed, Industrial Grade Handles
- * Industrial Grade Rubber Feet
- * Premium 3/8" Vinyl Laminated Plywood
- * Tongue and Groove Locking Fit
- * Low Profile Base
- * ATA 300 Rating
- * Road Ready Limited Lifetime Warranty

Shipping Dimensions (inch): 34.6 x 25.6 x 10

Shipping Weight (lbs): 48.4 lbs

Product Dimensions (inch): 30 x 24.8 x 9.2

Product Weight (lbs): 44 lbs

Shipping Dimensions (cm): 88 x 65 x 25.5

Shipping Weight (kg): 22 kg

Product Dimensions (cm): 86.5 x 63.8 x 23.5

Product Weight (kg): 20 kg

Mackie SR 24.4 Mixer Case

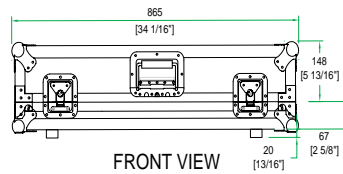

FRONT VIEW

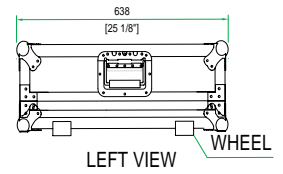

LEFT VIEW

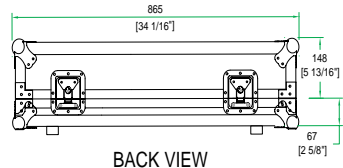

BACK VIEW

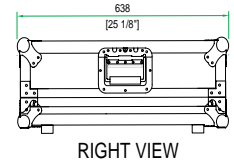

RIGHT VIEW



A-A VIEW

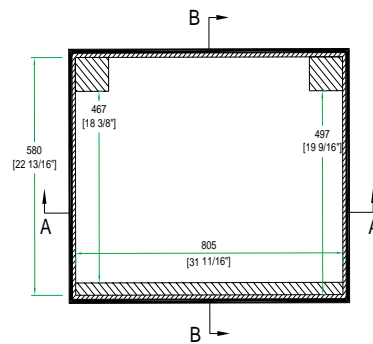

TOP VIEW OF COVER

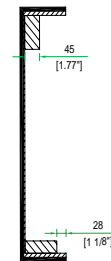

B-B VIEW

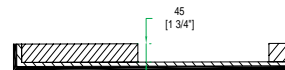

C-C VIEW

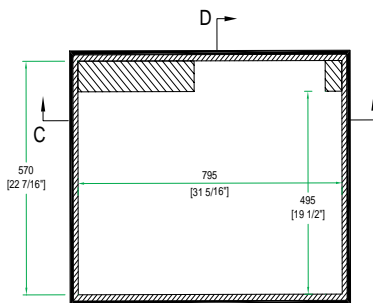

TOP VIEW OF BASE



D-D VIEW

www.roadreadycases.com

Road Ready Cases 18120 S. Broadway St. Unit B Gardena, Ca. 90248- 3536
 ph: 310 767 1772 fax: 310 767 1798