



RR11M16UCT

Good construction doesn't go out of style. That's our MO and that's why we create cases that are done right. Designed to make your life easier, the RR11M16UCT easily converts into a full working slant rack work station with a heavy-duty table that holds all your gear. Featuring a 11U slanted top rack for convenient mixer/CD controller placement and a 16U vertical rack for amp. and effect units, the RR11M16UCT also features an 20" mountable rack depth. To make a good thing even better we added an unique removable, rear hinged door for easy access to your gear. We even included a heavy-duty 3 1/2" caster kit for easy mobility.

Rugged Road Ready Features

- * Beefy, Stackable Ball Corners
- * Double Anchor Industrial Rivets
- * Recessed, Industrial Grade Latches
- * Recessed, Spring Loaded Handles
- * Premium 3/8" Vinyl Laminated Plywood
- * Tongue and Groove Locking Fit
- * Heavy Duty Rack Rails
- * Hinged Rear Access Door
- * Heavy Duty 3 1/2" Caster Kit
- * Heavy Duty Convertable Table
- * Mounting Hardware Included
- * ATA 300 Rating
- * Road Ready Limited Lifetime Warranty

Shipping Dimensions (inch): 22.2 x 26.5 x 40.6

Shipping Weight (lbs): 96.8

Product Dimensions (inch): 21.7 x 26 x 40

Product Weight (lbs): 90.9

Shipping Dimensions (cm): 56.5 x 67.3 x 103

Shipping Weight (kg): 44

Product Dimensions (cm): 55 x 66 x 101.5

Product Weight (kg): 41.3

5/05

11U SLANT RACK, 16U VERTICAL, WITH CASTERS AND SIDE TABLE

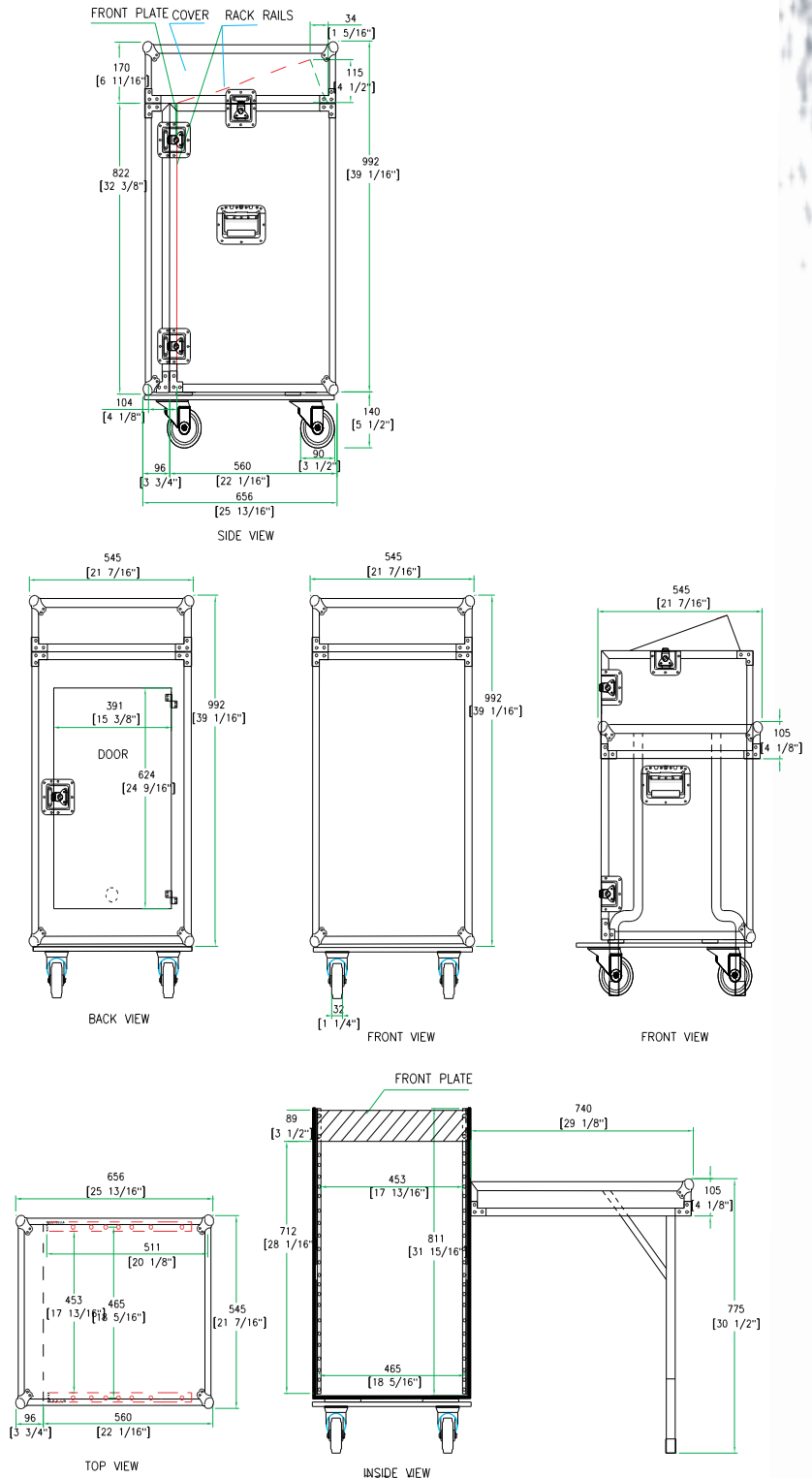

www.roadreadycases.com

Road Ready Cases 18120 S. Broadway St. Unit B Gardena, Ca. 90248- 3536
 ph: 310 767 1772 fax: 310 767 1798