



# RREMX500020

Created for the Pro's, the RREMX500020 mixer case is made for the journey and built to hold strong in high stress situations. Designed to fit the Yamaha EMX5000 20 Ch mixer, the RREMX500020 features a heavy-duty removable, latchable cover with our No Pressure Design to protect your mixer controls and a unique low profile base design that allows you to access your mixer's rear connection panel without removing your mixer from the case. Tougher than the pavement! That's the idea.

## Rugged Road Ready Features

- \* Beefy, Stackable Ball Corners
- \* Double Anchor Industrial Rivets
- \* Recessed, Industrial Grade Latches
- \* Recessed, Spring Loaded Handles
- \* Industrial Grade Rubber Feet
- \* Premium 3/8" Vinyl Laminated Plywood
- \* Tongue and Groove Locking Fit
- \* Low Profile Base Design
- \* ATA 300 Rating
- \* Road Ready Limited Lifetime Warranty

Shipping Dimensions (inch): 29.9 x 26.8 x 9.8

Shipping Weight (lbs): 39.6 lbs

Product Dimensions (inch): 29.5 x 26.4 x 9.4

Product Weight (lbs): 36.5 lbs

Shipping Dimensions (cm): 76 x 68 x 25

Shipping Weight (kg): 18 kg

Product Dimensions (cm): 75 x 67 x 23.8

Product Weight (kg): 16.6 kg

5/05

## Case for Yamaha EMX5000 20 Channel Mixer

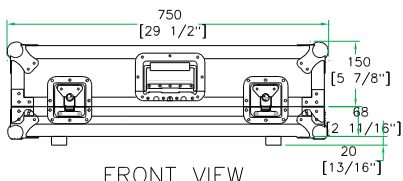

FRONT VIEW

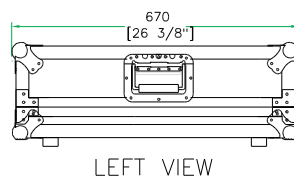

LEFT VIEW

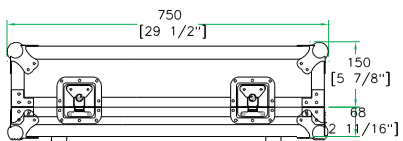

BACK VIEW

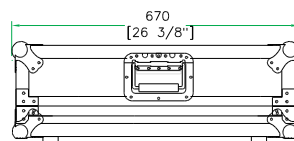

RIGHT VIEW

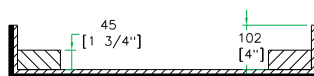

C-C VIEW

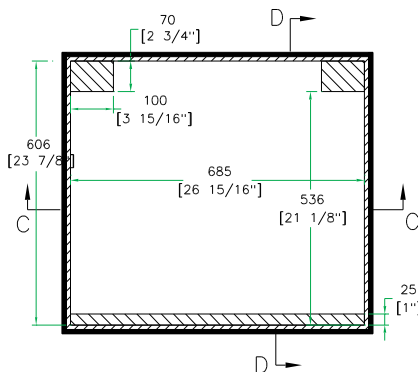

TOP VIEW OF COVER

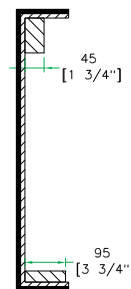

D-D VIEW



A-A VIEW

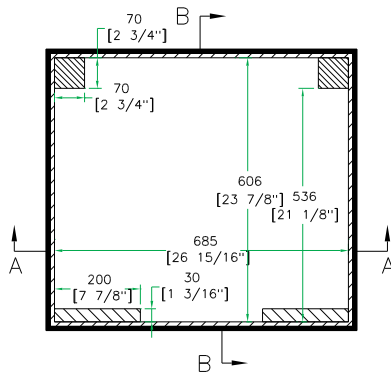

TOP VIEW OF BASE

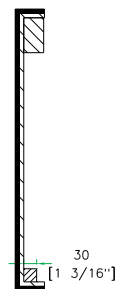

B-B VIEW

[www.roadreadycases.com](http://www.roadreadycases.com)

Road Ready Cases 18120 S. Broadway St. Unit B Gardena, Ca. 90248- 3536  
 ph: 310 767 1772 fax: 310 767 1798