



RRDJWS8

Forged out of the toughest materials around and ready to hit the road, the RRDJWS8 DJ workstation is built smart with our 3 level design that includes a 3-space vertical rack on the top for your CD controller, a slanted 7-space mid-level rack to accommodate your choice of 19" mixers and a bottom 8U rack for your CD player, effects, amps and more. And for added comfort we even included a unique rear hinged door for easy connections to your gear

Rugged Road Ready Features

- * Beefy, Stackable Ball Corners
- * Double Anchor Industrial Rivets
- * Recessed, Industrial Grade Latches
- * Recessed Industrial Grade Handles
- * Industrial Grade Rubber Feet
- * Premium 3/8" Vinyl Laminated Plywood
- * Tongue and Groove Locking Fit
- * Rear Hinged Access Door
- * Heavy Duty Rack Rails
- * Mounting Hardware Included
- * ATA 300 Rating
- * Road Ready Limited Lifetime Warranty

Shipping Dimensions (inch): 24.4" x 22" x 33.7"

Shipping Weight (lbs): 51.7 lbs

Product Dimensions (inch): 23.6" x 21.5" x 32.8"

Product Weight (lbs): 44 lbs

Shipping Dimensions (cm): 62 x 56 x 85.5

Shipping Weight (kg): 23.5 kg

Product Dimensions (cm): 59.9 x 54.5 x 83.3

Product Weight (kg): 20 kg

5/ 05

DJ Work Station Case for Dual CD Player, Controller, 19" Mixer, Top 3u, Mid 7u, Bottom 8u Racks

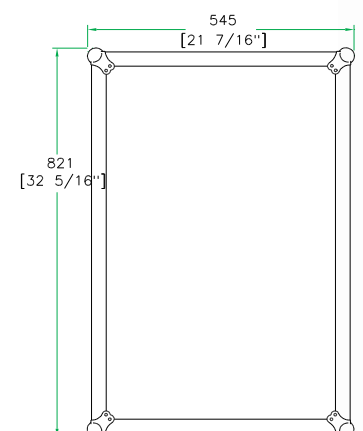
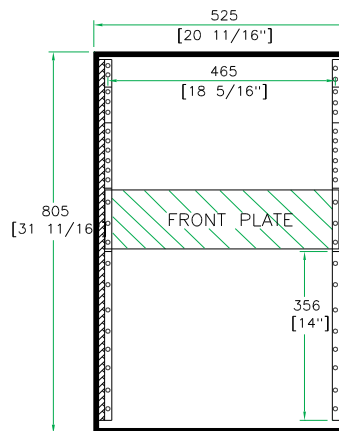
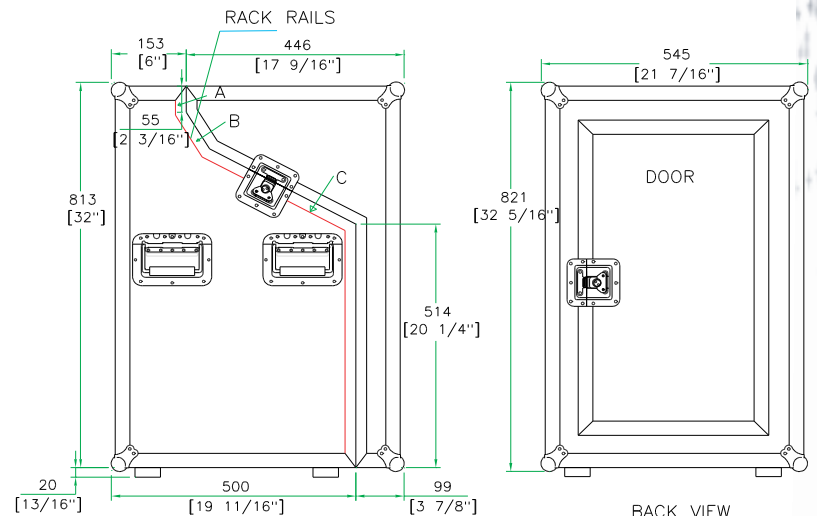

INSIDE VIEW

FRONT VIEW

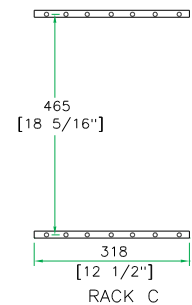
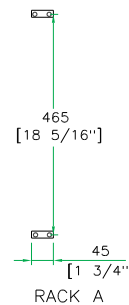

RACK A

RACK B

RACK C

www.roadreadycases.com

Road Ready Cases 18120 S. Broadway St. Unit B Gardena, Ca. 90248- 3536
 ph: 310 767 1772 fax: 310 767 1798