



RRDFX12

Created for the Pro's, the RRDFX12 mixer case is made for the journey and built to hold strong in high stress situations. Designed to fit the Mackie DFX12 mixer, the RRDFX12 features a heavy-duty removable, latchable cover with our No Pressure Design to protect your mixer controls and a unique low profile base design that allows you to access your mixer's rear connection panel without removing your mixer from the case. Tougher than the pavement! That's the idea.

Rugged Road Ready

Features

- * Double Anchor Industrial Rivets
- * Beefy, Stackable Ball Corners
- * Recessed, Industrial Grade Latches
- * Recessed Spring Loaded Handle
- * Industrial Grade Rubber Feet
- * Premium 3/8" Vinyl Laminated Plywood
- * Tongue and Groove Locking Fit
- * Low Profile Base Design
- * ATA 300 Rating
- * Road Ready Limited Lifetime Warranty

CASE FOR MACKIE DFX12 MIXER

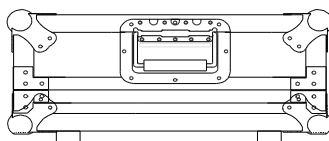

FRONT VIEW

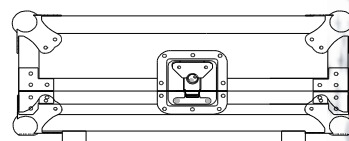

LEFT VIEW

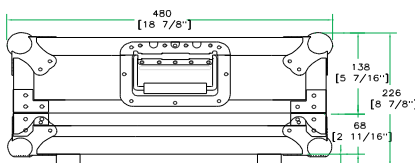

BACK VIEW

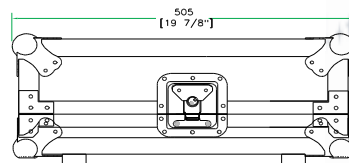

RIGHT VIEW

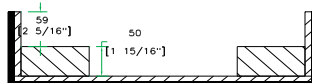

A-A VIEW

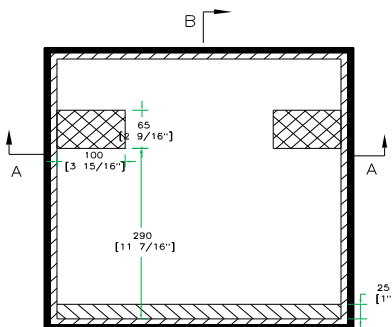

TOP VIEW OF COVER

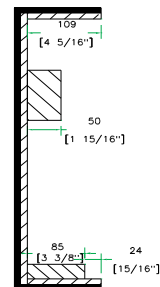

B-B VIEW

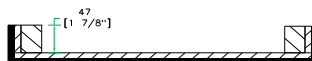

C-C VIEW

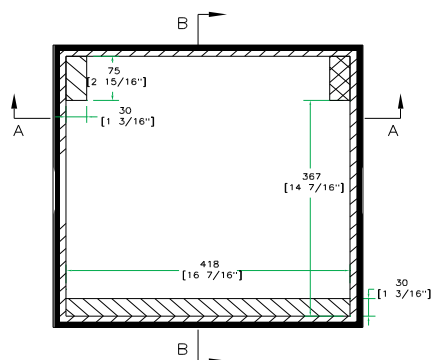

TOP VIEW OF BASE

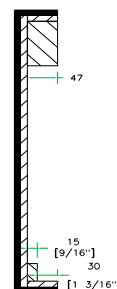

D-D VIEW

www.roadreadycases.com

Road Ready Cases 18120 S. Broadway St. Unit B Gardena, Ca. 90248- 3536
ph: 310 767 1772 fax: 310 767 1798