



RRCFX16

Created for the Pro's, the RRCFX16 mixer case is made for the journey and built to hold strong in high stress situations. Designed to fit the Mackie CFX16 Pro mixer, the RRCFX16 features a heavy-duty, removable cover crafted with our no-pressure design to protect your mixer controls. Our unique low profile base allows you to access the mixer's rear connection panel without removing your mixer from the case and we even threw in a rear access door for easy AC connections. Tougher than the pavement! That's the idea.

Rugged Road Ready Features

- * Double Anchor Industrial Rivets
- * Recessed, Industrial Grade Latches
- * Industrial Grade Rubber Feet
- * Spring Loaded Handle
- * Premium 3/8" Vinyl Laminated Plywood
- * Tongue and Groove Locking Fit
- * Low Profile Base
- * Rear Access Door
- * Road Ready Limited Lifetime Warranty

Shipping Dimensions (inch): 25.2" x 19.4" x 7.9"

Shipping Weight (lbs): 18.5 lbs

Product Dimensions (inch): 24.8" x 19" x 7.1"

Product Weight (lbs): 16 lbs

Shipping Dimensions (cm): 64.1 x 49.2 x 20

Shipping Weight (kg): 8.4 kg

Product Dimensions (cm): 63.1 x 48.2 x 18

Product Weight (kg): 7.3 kg

Mackie CFX16 Mixer Case

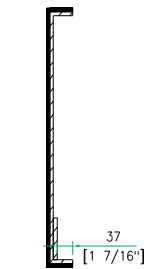
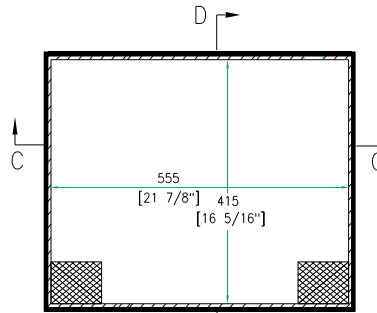
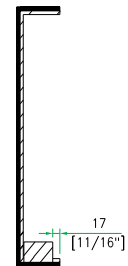
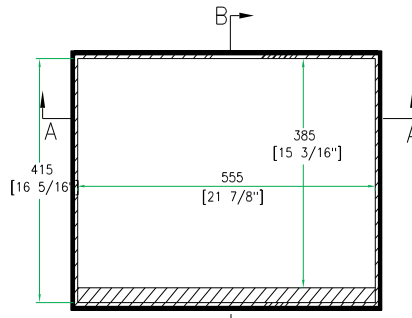
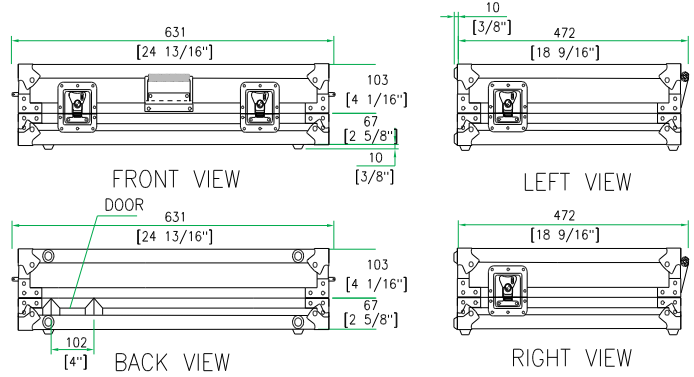

www.roadreadycases.com

Road Ready Cases 18120 S. Broadway St. Unit B Gardena, Ca. 90248- 3536
 ph: 310 767 1772 fax: 310 767 1798