



RR8UED

Built smart with flexibility and comfort in mind, the RR8UED accommodates professional effects units up to 8U. This rugged case is designed to fit all standard 19" rack-mountable equipment, features dual rack rails (mounted front and back at a 12 3/8" rack depth) and includes two removable covers for easy access to both sides of your rack. Built for the long haul!

Rugged Road Ready Features

- * Beefy, Stackable Ball Corners
- * Double Anchor Industrial Rivets
- * Recessed, Industrial Grade Latches
- * Recessed, Spring Loaded Handles
- * Industrial Grade Rubber Feet
- * Premium 3/8" Vinyl Laminated Plywood
- * Tongue and Groove Locking Fit
- * Heavy Duty Rack Rails
- * Mounting Hardware Included
- * ATA 300 Rating
- * Road Ready Limited Lifetime Warranty

Shipping Dimensions (inch): 21.9 x 21.5 x 17.1

Shipping Weight (lbs): 37.8

Product Dimensions (inch): 21.5 x 21.2 x 16.5

Product Weight (lbs): 34.3

Shipping Dimensions (cm): 55.5 x 54.5 x 43.5

Shipping Weight (kg): 17.2

Product Dimensions (cm): 54.5 x 53.8 x 41.8

Product Weight (kg): 15.6

8U Deluxe Effect Rack Case

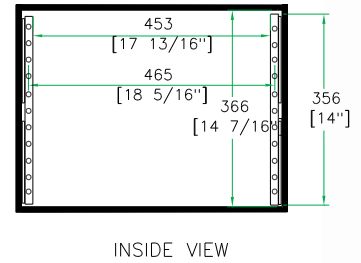
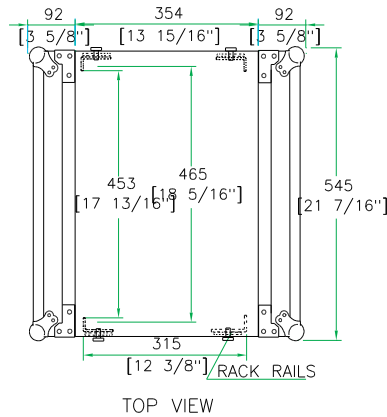
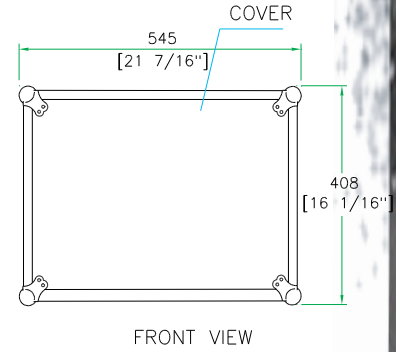
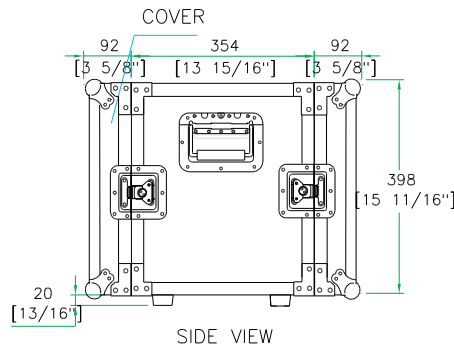

www.roadreadycases.com

Road Ready Cases 18120 S. Broadway St. Unit B Gardena, Ca. 90248- 3536
 ph: 310 767 1772 fax: 310 767 1798