



## RR8UADS

Built to take a pounding and come back for more, the RR8UADS protects your gear from even the most ground-breaking abuse. Crafted with our exclusive case-within-a case design that features an unique integral suspension system the RR8UADS provides unparallel protection against even the most rigorous trauma. Built smart with dual rack rails for flexibility (mounted front and back an 16 1/4" rack depth) and two removable covers for easy access to your gear, the RR8UADS features 8U 's of rack space. Bring it on!"

### Rugged Road Ready Features

- \* Beefy, Stackable Ball Corners
- \* Double Anchor Industrial Rivets
- \* Recessed, Industrial Grade Latches
- \* Recessed, Spring Loaded Handles
- \* Industrial Grade Rubber Feet
- \* Premium 3/8" Vinyl Laminated Plywood
- \* Tongue and Groove Locking Fit
- \* Heavy Duty Rack Rails
- \* Mounting Hardware Included
- \* Shock Mount Technology
- \* ATA 300 Rating
- \* Road Ready Limited Lifetime Warranty

Shipping Dimensions ( inch): 25.2 x 26.2 x 20.9

Shipping Weight ( lbs): 83.6

Product Dimensions (inch): 25.6 x 25.2 x 20.2

Product Weight (lbs): 75.2

Shipping Dimensions ( cm): 64 x 66.5 x 53

Shipping Weight ( kg): 38

Product Dimensions (cm): 65.1 x 64.1 x 51.4

Product Weight (kg): 34.2

3/05

## 8U Deluxe Shock Mount Amplifier Rack Case

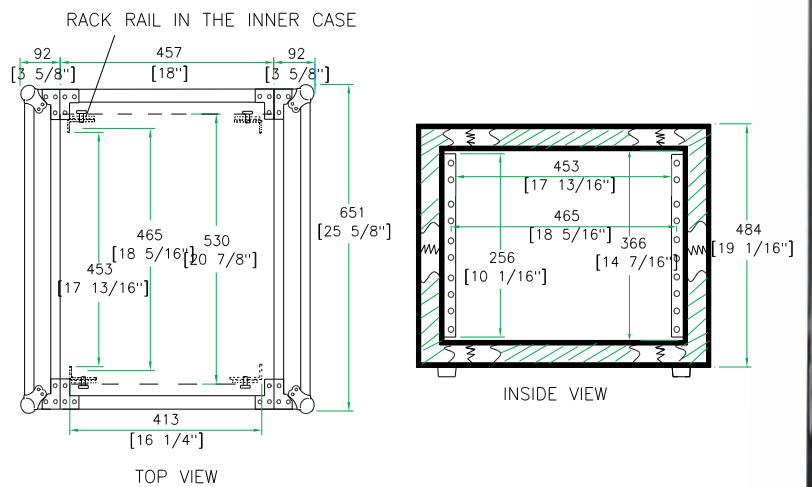
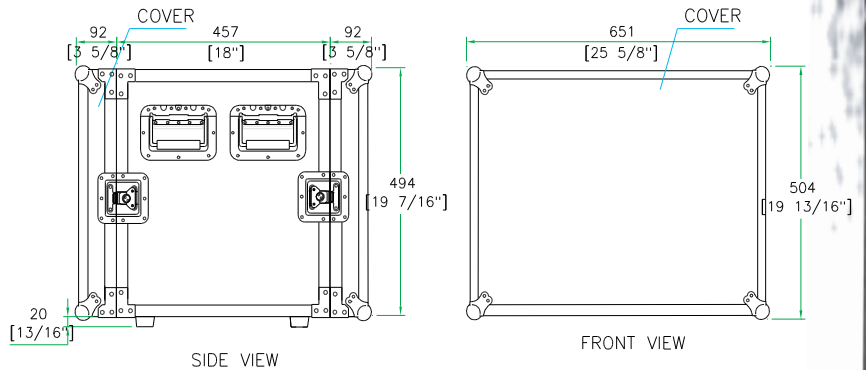

Need Optimal Road Ready Accessories to help outfit your Amp Rack? Check out our Road Ready Caster Kit ( RRWAD).

[www.roadreadycases.com](http://www.roadreadycases.com)

Road Ready Cases 18120 S. Broadway St. Unit B Gardena, Ca. 90248- 3536  
 ph: 310 767 1772 fax: 310 767 1798