



RR6UED

Built smart with flexibility and comfort in mind, the RR6UED accommodates professional effects units up to 6U. This rugged case is designed to fit all standard 19" rack-mountable equipment, features dual rack rails (mounted front and back at a 12 3/8" rack depth) and includes two removable covers for easy access to both sides of your rack. Built for the long haul!

Rugged Road Ready Features

- * Beefy, Stackable Ball Corners
- * Double Anchor Industrial Rivets
- * Recessed, Industrial Grade Latches
- * Recessed, Spring Loaded Handles
- * Industrial Grade Rubber Feet
- * Premium 3/8" Vinyl Laminated Plywood
- * Tongue and Groove Locking Fit
- * Heavy Duty Rack Rails
- * Mounting Hardware Included
- * ATA 300 Rating
- * Road Ready Limited Lifetime Warranty

Shipping Dimensions (inch): 21.9 x 21.5 x 13.6

Shipping Weight (lbs): 31.9

Product Dimensions (inch): 21.5 x 21.2 x 13

Product Weight (lbs): 27.5

Shipping Dimensions (cm): 55.5 x 54.5 x 34.5

Shipping Weight (kg): 14.5

Product Dimensions (cm): 54.5 x 53.8 x 32.9

Product Weight (kg): 12.5

6U Deluxe Effect Rack Case

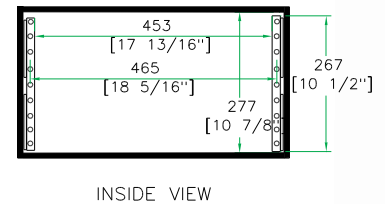
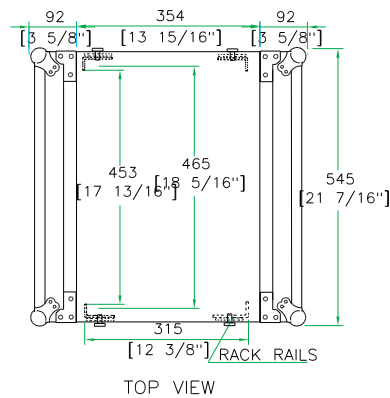
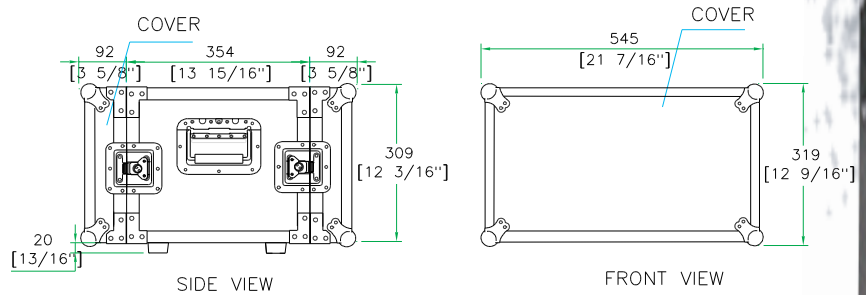

www.roadreadycases.com

Road Ready Cases 18120 S. Broadway St. Unit B Gardena, Ca. 90248- 3536
 ph: 310 767 1772 fax: 310 767 1798