



RR4UED

Built smart with flexibility and comfort in mind, the RR4UED accommodates professional effects units up to 4U. This rugged case is designed to fit all standard 19" rack-mountable equipment, features dual rack rails (mounted front and back at a 12 3/8" rack depth) and includes two removable covers for easy access to both sides of your rack. Built for the long haul!

Rugged Road Ready

Features

- * Beefy, Stackable Ball Corners
- * Double Anchor Industrial Rivets
- * Recessed, Industrial Grade Latches
- * Recessed, Spring Loaded Handles
- * Industrial Grade Rubber Feet
- * Premium 3/8" Vinyl Laminated Plywood
- * Tongue and Groove Locking Fit
- * Heavy Duty Rack Rails
- * Mounting Hardware Included
- * ATA 300 Rating
- * Road Ready Limited Lifetime Warranty

Shipping Dimensions (inch): 21.9 x 21.5 x 10

Shipping Weight (lbs): 25.5

Product Dimensions (inch): 21.5 x 21.2 x 9.4

Product Weight (lbs): 21.6

Shipping Dimensions (cm): 55 x 54.5 x 25.5

Shipping Weight (kg): 11.6

Product Dimensions (cm): 54.5 x 53.8 x 24

Product Weight (kg): 9.8

4U Deluxe Effect Rack Case

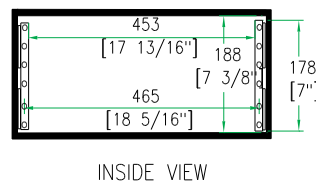
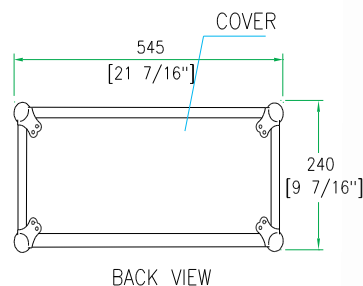
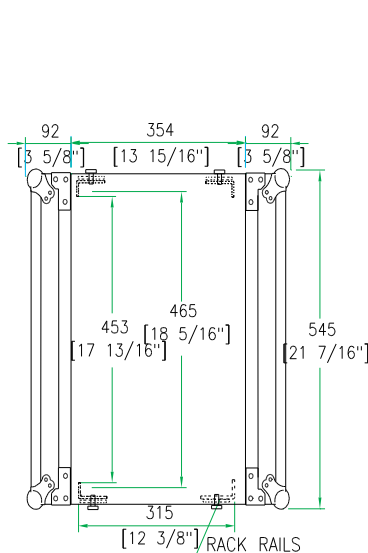
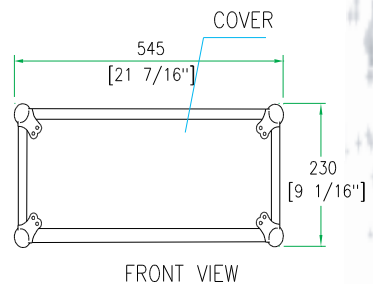
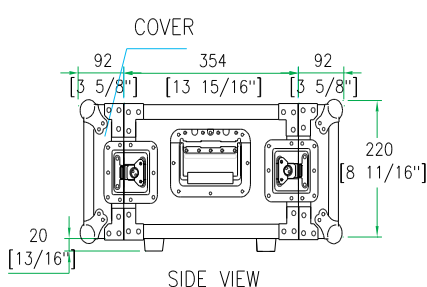

TOP VIEW