



RR3212W

Created for the Pro's, the RR3212W mixer case is made for the journey and built to hold strong in high stress situations. Designed to fit the Yamaha GA32/12 and MC32/12 mixing consoles, the RR3212W features a heavy-duty, removable, latchable cover for easy access to your gear and our unique low profile base design that allows you to access your mixer's rear connection panel without removing your mixer from the case. And to make transporting your gear even easier we included our low profile wheels for sleek, stealth mobility. Tougher than the pavement! That's the idea.

Rugged Road Ready Features

- * Heavy Duty Industrial Grade Ball Corners
- * Double Anchor Industrial Rivets
- * Recessed, Industrial Grade Latches
- * Recessed, Industrial Grade Handles
- * Industrial Grade Rubber Feet
- * Premium 3/8" Vinyl Laminated Plywood
- * Tongue and Groove Locking Fit
- * Low Profile Base
- * Low Profile Wheels
- * ATA 300 Rating
- * Road Ready Limited Lifetime Warranty

Shipping Dimensions (inch): 57.7x 34.3 x 10.4

Shipping Weight (lbs): 23.5 lbs

Product Dimensions (inch): 20.9 x 25.6 x 8.9

Product Weight (lbs): 19.1 lbs

Shipping Dimensions (cm): 146.5 x 87 x 26.5

Shipping Weight (kg): 10.7 kg

Product Dimensions (cm): 53 x 65 x 22.5

Product Weight (kg): 8.7 kg

3/2005

YAMAHA GA 32/12 & MC 32/12, 32 CHANNEL MIXER CASE WITH WHEELS

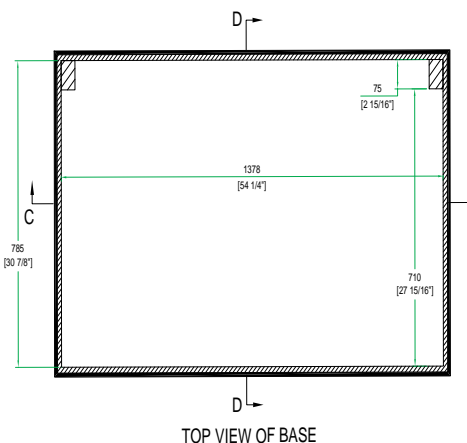
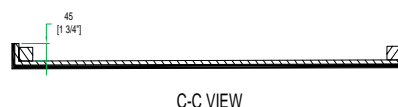
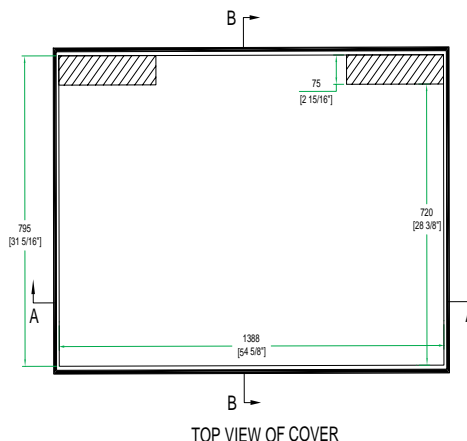
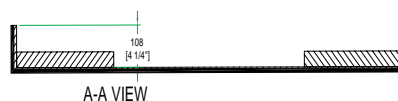
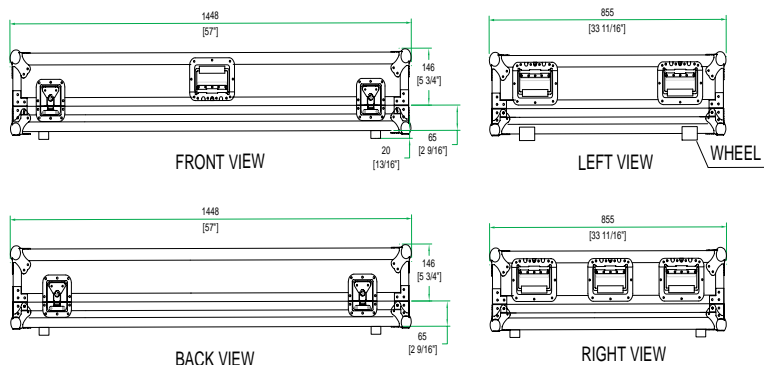

www.roadreadycases.com

Road Ready Cases 18120 S. Broadway St. Unit B Gardena, Ca. 90248- 3536
ph: 310 767 1772 fax: 310 767 1798