



RR2UAD

Amp it baby and party like a rock star! Road Ready's RR2UAD is built for the long haul. Crafted from raw edged materials to accommodate pro amps up to 2U, the RR2UAD is built smart with dual rack rails (mounted front and back at an 16 1/4" rack depth) and features 2 removable heavy duty covers for easy access to your gear.

Rugged Road Ready

Features

- * Beefy, Stackable Ball Corners
- * Double Anchor Industrial Rivets
- * Recessed, Industrial Grade Latches
- * Recessed, Spring Loaded Handles
- * Industrial Grade Rubber Feet
- * Premium 3/8" Vinyl Laminated Plywood
- * Tongue and Groove Locking Fit
- * Heavy Duty Rack Rails
- * Mounting Hardware Included
- * ATA 300 Rating
- * Road Ready Limited Lifetime Warranty

Shipping Dimensions (inch): 22.8 x 23.6 x 6.3

Shipping Weight (lbs): 20.2

Product Dimensions (inch): 22.2 x 25.1 x 5.8

Product Weight (lbs): 18.3

Shipping Dimensions (cm): 58 x 60 x 16

Shipping Weight (kg): 9.2

Product Dimensions (cm): 56.5 x 63.7 x 14.7

Product Weight (kg): 8.3

2U Deluxe Amplifier Rack Case

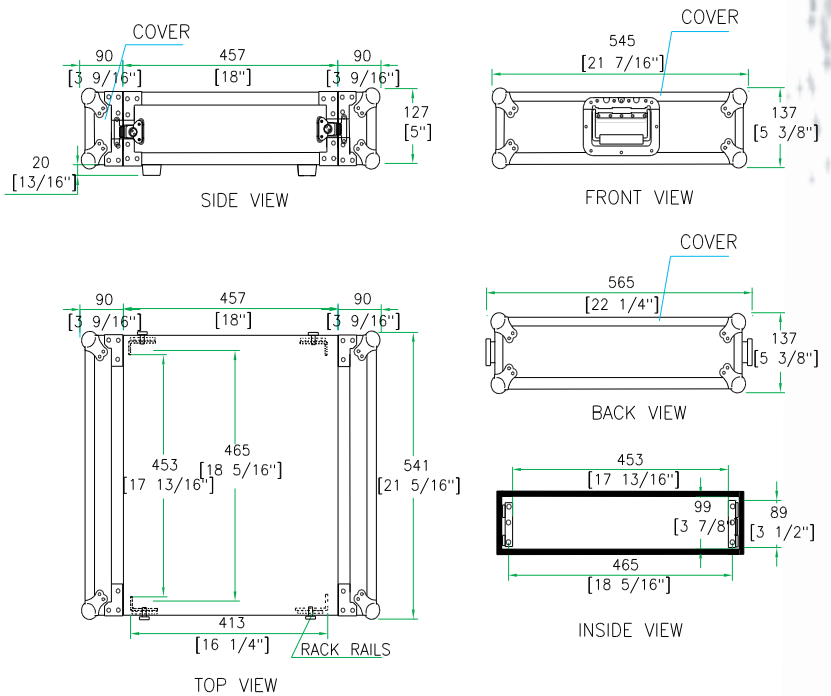

Need Optimal Road Ready Accessories to help outfit your Amp Rack? Check out our Road Ready Caster Kit (RRWAD) or our rolling base with storage drawer (RR6WD)

www.roadreadycases.com

Road Ready Cases 18120 S. Broadway St. Unit B Gardena, Ca. 90248- 3536
 ph: 310 767 1772 fax: 310 767 1798