



RR18UADSW

Built to take a pounding and come back for more, the RR18UADSW protects your gear from even the most ground-breaking abuse. Crafted with our exclusive case-within-a-case design that features an unique integral suspension system the RR18UADSW provides un-parallel protection against even the most rigorous trauma. Built smart with dual rack rails for flexibility (mounted front and back an 16 1/4" rack depth) and two removable covers for easy access to your gear, the RR18UADSW features 18U 's of rack space. Bring it on!

Rugged Road Ready Features

- * Beefy, Stackable Ball Corners
- * Double Anchor Industrial Rivets
- * Recessed, Industrial Grade Latches
- * Recessed, Spring Loaded Handles
- * Industrial Grade Rubber Feet
- * Premium 3/8" Vinyl Laminated Plywood
- * Tongue and Groove Locking Fit
- * Heavy Duty Rack Rails
- * Mounting Hardware Included
- * Shock Mount Technology
- * 3 1/2" Heavy Duty Caster
- * ATA 300 Rating
- * Road Ready Limited Lifetime Warranty

Shipping Dimensions (inch): 26.2 X 25.8 X 38.2

Shipping Weight (lbs): 112.2 lbs

Product Dimensions (inch): 25.6 x 25.2 x 42.5

Product Weight (lbs): 106 lbs

Shipping Dimensions (cm): 66.5 x 65.5 x 97

Shipping Weight (kg): 51 kg

Product Dimensions (cm): 65.1 x 64.1 x 107.9

Product Weight (kg): 48.2 kg

18U Deluxe Shock Mount Amplifier Rack Case w/ Caster

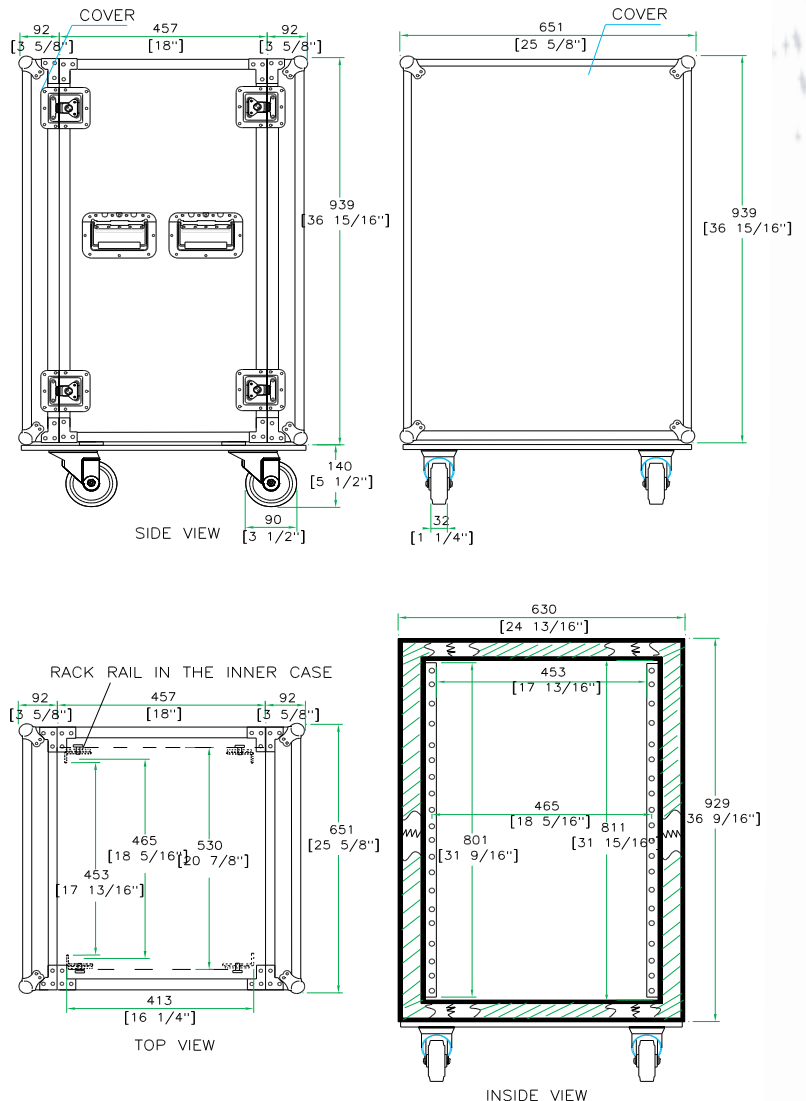

www.roadreadycases.com