



# RR16UED

Built smart with flexibility and comfort in mind, the RR16UED accommodates professional effects units up to 16U. This rugged case is designed to fit all standard 19" rack-mountable equipment, features dual rack rails (mounted front and back at a 12 3/8" rack depth) and includes two removable covers for easy access to both sides of your rack. Built for the long haul!

## Rugged Road Ready Features

- \* Beefy, Stackable Ball Corners
- \* Double Anchor Industrial Rivets
- \* Recessed, Industrial Grade Latches
- \* Recessed, Spring Loaded Handles
- \* Industrial Grade Rubber Feet
- \* Premium 3/8" Vinyl Laminated Plywood
- \* Tongue and Groove Locking Fit
- \* Heavy Duty Rack Rails
- \* Mounting Hardware Included
- \* ATA 300 Rating
- \* Road Ready Limited Lifetime Warranty

Shipping Dimensions ( inch): 21.9 x 21.5 x 31.1

Shipping Weight ( lbs): 73.7

Product Dimensions (inch): 21.5 x 21.2 x 30.5

Product Weight (lbs): 66.2

Shipping Dimensions ( cm): 55.5 x 54.5 x 79

Shipping Weight ( kg): 33.5

Product Dimensions (cm): 54.5 x 53.8 x 77.4

Product Weight (kg): 30.1

5/05

## 16U Deluxe Effect Rack Case

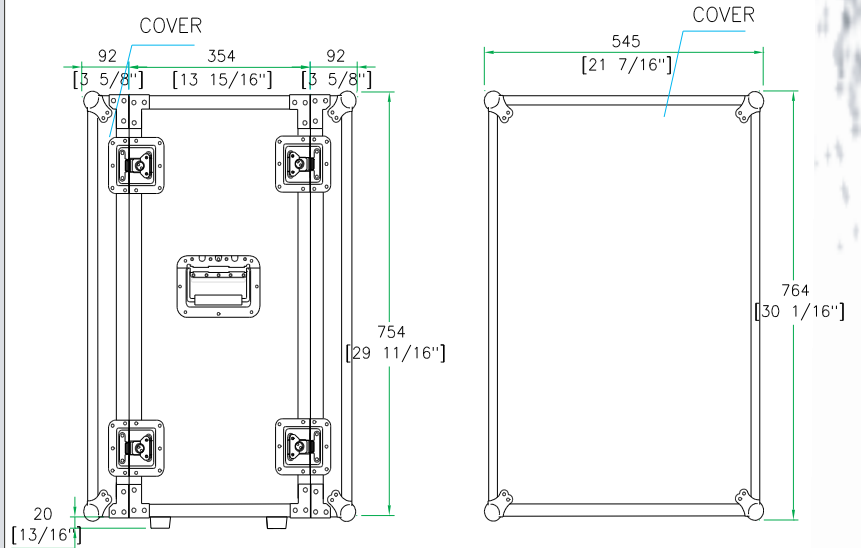

SIDE VIEW

FRONT VIEW

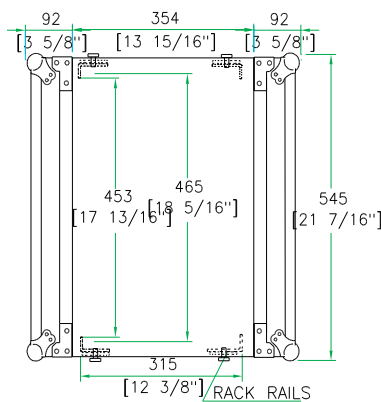

TOP VIEW

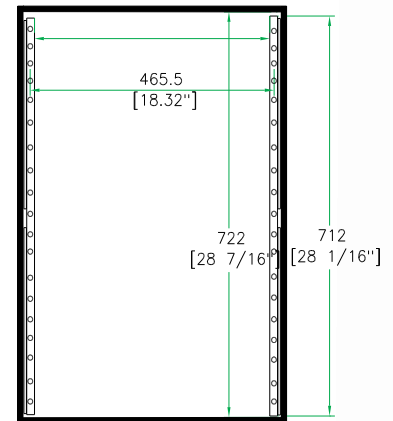

INSIDE VIEW

[www.roadreadycases.com](http://www.roadreadycases.com)

Road Ready Cases 18120 S. Broadway St. Unit B Gardena, Ca. 90248- 3536  
 ph: 310 767 1772 fax: 310 767 1798