



RR14UAD24W

Amp it baby and party like a rock star! Road Ready's RR14UAD24W is built for the long haul. Crafted from raw edged materials to accommodate pro amps up to 14U, the RR14UAD24W is built smart with dual rack rails (mounted front and back at an 22 5/8" rack depth) and 1/2" plywood construction for extra strength. It features 2 removable heavy duty covers for easy access to your gear, and because we know that lugging around your gear can be a drag, we threw in a rugged Caster Board for easy mobility.

Rugged Road Ready

Features

- * Beefy, Stackable Ball Corners
- * Double Anchor Industrial Rivets
- * Recessed, Industrial Grade Latches
- * Recessed, Spring Loaded Handles
- * Industrial Grade Rubber Feet
- * Premium 1/2" Vinyl Laminated Plywood
- * Tongue and Groove Locking Fit
- * Heavy Duty Rack Rails
- * Mounting Hardware Included
- * 3 1/2" Heavy Duty Caster
- * ATA 300 Rating
- * Road Ready Limited Lifetime Warranty

Shipping Dimensions (inch): 32.9 x 22.2 x 28.1

Shipping Weight (lbs): 86.9 lbs

Product Dimensions (inch): 25.6 x 25.2 x 32

Product Weight (lbs): 79.2 lbs

Shipping Dimensions (cm): 83.5 x 56.5 x 71.5

Shipping Weight (kg): 39.5 kg

Product Dimensions (cm): 82.0 x 55.0 x 85.0

Product Weight (kg): 36 kg

14U AMPLIFIER DELUXE CASE- 24" BODY DEPTH WITH CASTER BOARD- 1/2" PLYWOOD

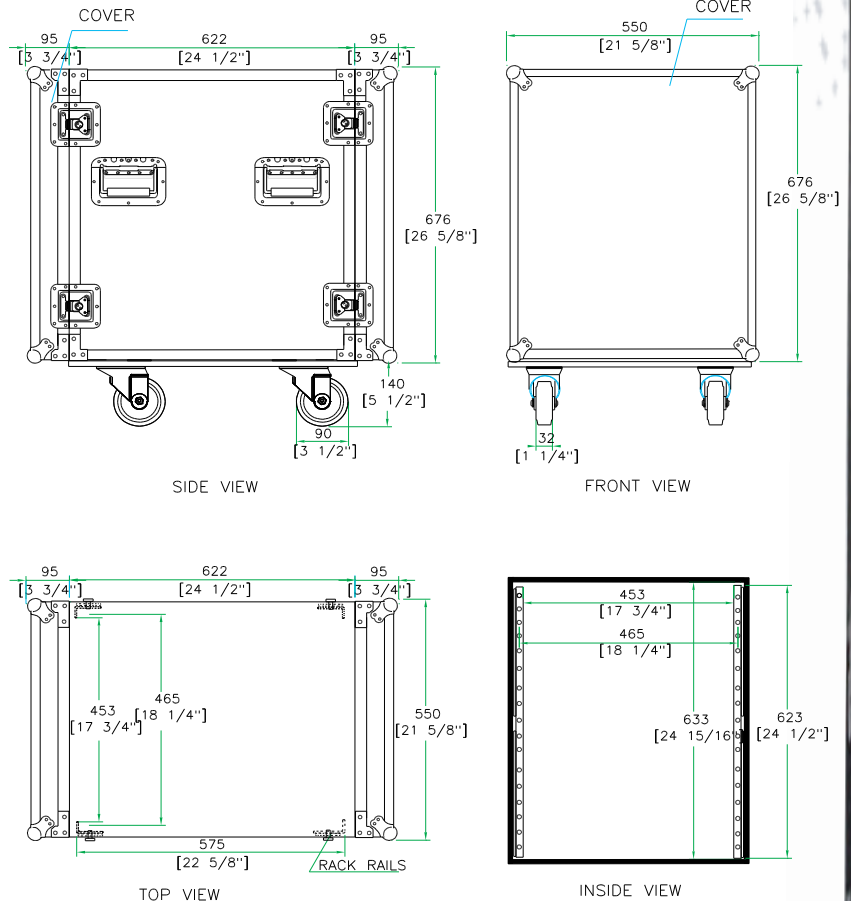

www.roadreadycases.com

Road Ready Cases 18120 S. Broadway St. Unit B Gardena, Ca. 90248- 3536
ph: 310 767 1772 fax: 310 767 1798