



# RR1200AS

The ultimate hook-up of style and innovation, the RR1200AS is constructed to hold-up to 1000 miles of abuse. We know that clear crisp sound is what it's all about so we designed this case with an advanced Acoustic Suspension system to provide the ultimate control of turntable vibration and help eliminate feedback. The RR1200AS's rugged construction features our unique modular poly-foam padding system which allows you to create the perfect custom space for virtually any turntable on the market including industry standards like Technics 1200's, Vestax PDX2000 and Numark TT-X1 models. We also threw in a rear access cable port for no hassle connections. Hey, we're looking out for you.

## Rugged Road Ready Features

- \* Beefy, Stackable Ball Corners
- \* Double Anchor Industrial Rivets
- \* Recessed, Industrial Grade Latches
- \* Recessed, Spring Loaded Handles
- \* Industrial Grade Rubber Feet
- \* Premium 3/8" Vinyl Laminated Plywood
- \* Tongue and Groove Locking Fit
- \* Rear Access Cable Port
- \* Acoustic Suspension System
- \* ATA 300 Rating
- \* Road Ready Limited Lifetime Warranty

Shipping Dimensions ( inch):

Shipping Weight ( lbs):

Product Dimensions (inch):

Product Weight (lbs):

Shipping Dimensions ( cm):

Shipping Weight ( kg):

Product Dimensions (cm):

Product Weight (kg):

## ACOUSTIC SUSPENSION DELUXE TURNTABLE CASE

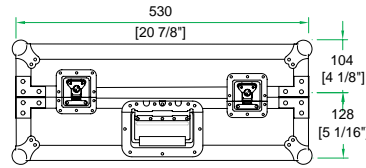

FRONT VIEW

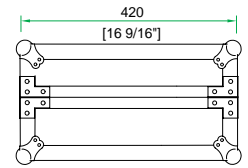

LEFT VIEW

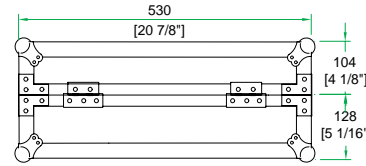

BACK VIEW

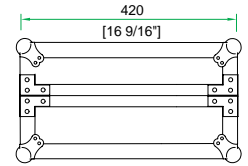

RIGHT VIEW

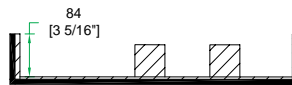

A-A VIEW

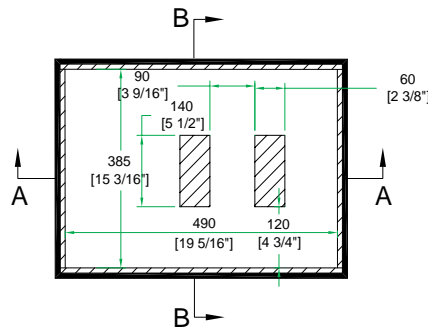

TOP VIEW OF COVER

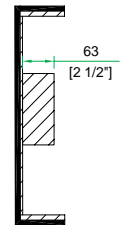

B-B VIEW

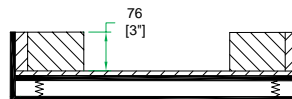

C-C VIEW

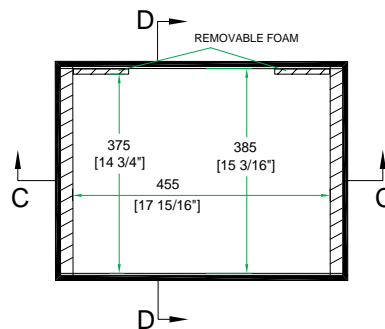

TOP VIEW OF BASE



D-D VIEW

[www.roadreadycases.com](http://www.roadreadycases.com)

Road Ready Cases 18120 S. Broadway St. Unit B Gardena, Ca. 90248- 3536  
ph: 310 767 1772 fax: 310 767 1798