



RR10UADS

Built to take a pounding and come back for more, the RR10UADS protects your gear from even the most ground-breaking abuse. Crafted with our exclusive case-within-a-case design that features an unique integral suspension system the RR10UADS provides un-parallel protection against even the most rigorous trauma. Built smart with dual rack rails for flexibility (mounted front and back an 16 1/4" rack depth) and two removable covers for easy access to your gear, the RR10UADS features 10U 's of rack space. Bring it on!

Rugged Road Ready

Features

- * Beefy, Stackable Ball Corners
- * Double Anchor Industrial Rivets
- * Recessed, Industrial Grade Latches
- * Recessed, Spring Loaded Handles
- * Industrial Grade Rubber Feet
- * Premium 3/8" Vinyl Laminated Plywood
- * Tongue and Groove Locking Fit
- * Heavy Duty Rack Rails
- * Mounting Hardware Included
- * Shock Mount Technology
- * ATA 300 Rating
- * Road Ready Limited Lifetime Warranty

Shipping Dimensions (inch): 26.2" x 25.6" x 24.8"

Shipping Weight (lbs): 74.4 lbs

Product Dimensions (inch): 25.6" x 25.2" x 23.7"

Product Weight (lbs): 67.7 lbs

Shipping Dimensions (cm): 66.5 x 65 x 63

Shipping Weight (kg): 33.8 kg

Product Dimensions (cm): 65.1 x 64.1 x 60.3

Product Weight (kg): 30.8 kg

10U Deluxe Shock Mount Amplifier Rack Case

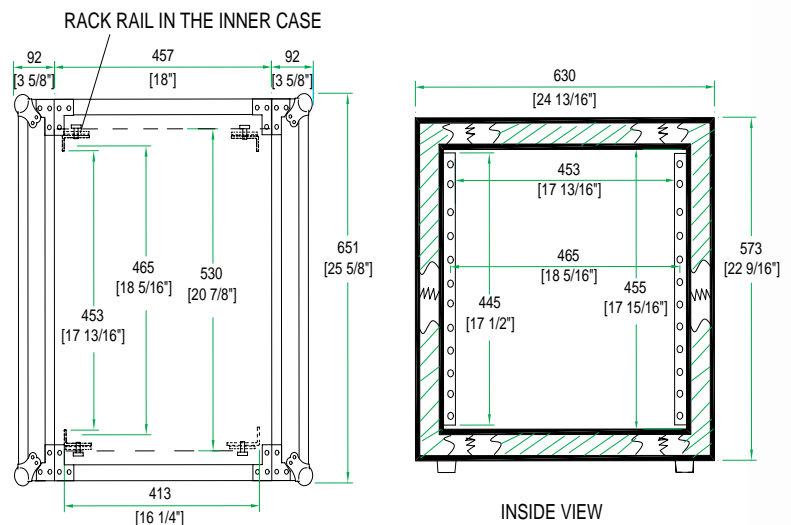
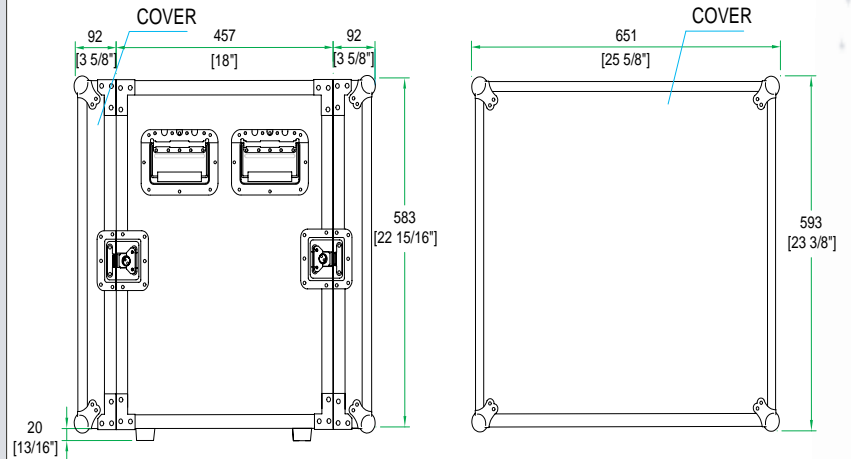

www.roadreadycases.com