

Installation and Operation Manual

SOLO – EXECUTIVE

Wireless Microphone System

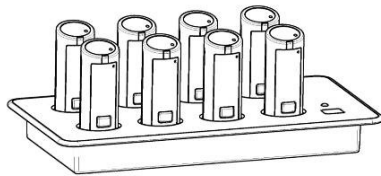
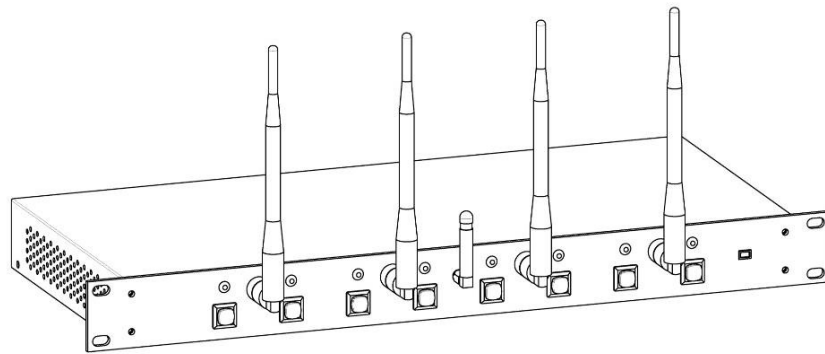

© 2006 REVOLABS, INC. All rights reserved.
No part of this document may be reproduced in any form or by any means without express written permission from Revolabs, Inc. Product specifications are subject to change without notice.

Table of Contents

System Components	2
Solo Executive Charger Base	3
Power Module	3
System Mute Switch.....	3
Solo Personal Microphone Modules.....	3
Charging the Batteries	4
Using the Microphone	4
Solo Executive Base Station	5
Installation.....	6
Connections	6
Set-up	6
Pairing Wireless Microphones to Base Station	6
Pairing Charger Base to Base Station	7
Using Multiple Systems.....	8
System Mute Function Switch.....	8
DB25 Control Port	8
System Functions	9
System Specifications	10
Indicator LEDs	11
Warranty	12
Safety and General Information.....	13

Introduction

Congratulations on the purchase of a Revolabs digital wireless communication system! We are pleased that you have chosen the Solo Executive Wireless Microphone System with 1.9 GHz DECT technology. The Solo Executive provides high band-width audio from multiple wireless microphones enabling reliable, un-tethered communications in audio and video conferences.

The Solo Executive Wireless Microphone System is a unique marriage of innovative technology and ergonomic stylish design. This product enhances audio communication in many enterprise and professional applications. The system uses Time Division Multiple Access (TDMA) spread spectrum technology. This technology allows the microphones to co-exist with other wireless products such as wireless LANs (802.11B&G), as well as allowing digital encryption technology to ensure secure communications.

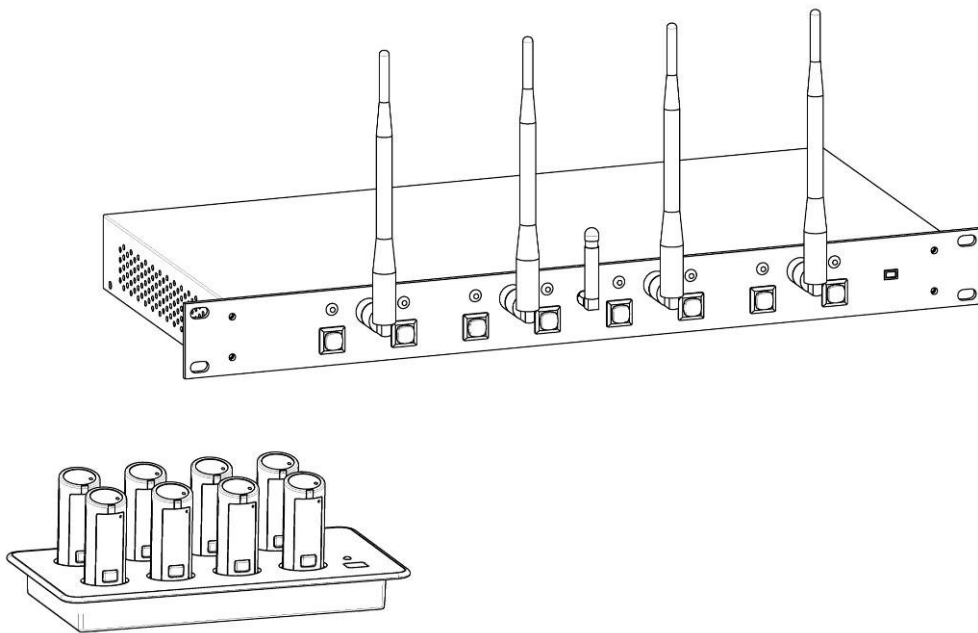

System Components

Your Solo Executive System package contains a rackmountable Base Station, a Charger Base and eight wireless microphones. The Base Station houses the processor and one end of the wireless connection. It has two sets of diversity antennas and provides individual line-level audio in and out for each microphone channel. This allows for additional post processing by external multi-channel equipment. The Charger Base unit stores and charges the wireless microphones when not in use. There are many features that this system provides that increase the productivity of a conference call including consistent audio input from all participants, decreased room noise, auto and manual mute, wireless encryption, re-synchronization and full duplex audio.

Solo Executive Charger Base

The Charger Base is used for storage and charging the microphone when not in use. Microphones must be properly inserted into the base and seated flush for charging to occur.

1. System **MUTE** Switch — overrides individual Microphone mute function.
2. LED indicator — power / mute status indicator.
3. Charger Bays — charges up to 8 Microphones.
4. Line Cord Receptacle — power supply input (on rear).

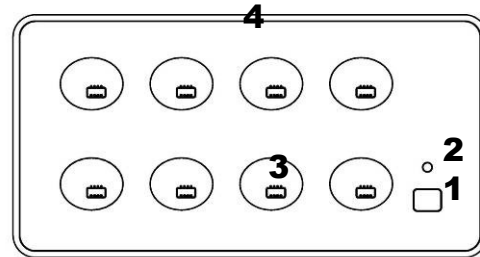

Power Module

The Charger Base requires 5VDC power. Plug the supplied AC adapter into an appropriate power outlet 110-220 AC, 50-60Hz. The power LED on the Charger Base will illuminate.

System Mute Switch

There is a system **MUTE** button on the Charger Base. In normal operation the LED will be solid GREEN (power on). In this mode, the microphone devices can individually mute themselves. Pressing the system **MUTE** button will mute "all" wireless microphones in the system and the Charger Base LED will turn RED. All microphones active in the system will also change to flashing RED LED status indicating muted microphone audio. To un-mute all microphones, press the system **MUTE** button again. The Charger Base LED will return to solid GREEN, and all microphones will return to their previous state prior to the system mute.

Note: Pressing the **MUTE** button on a microphone while the system mute is active (solid RED LED on Charger Base) will NOT un-mute the microphone.

Solo Personal Microphone Modules

The wireless personal microphone modules are synchronized to the rackmounted Base Station and can be worn on the user's shirt pocket, lapel or on a lanyard. They provide high quality full duplex audio between each user and the conferencing phone/system. This system allows attendees to step out of the conference room area and still participate in the call.

1. Mute Button — controls multiple microphone functions.
2. Charging Port — accepts the storage base battery charger.
3. LED Indicator — provides a visual status about wireless module.
4. Earpiece Jack — accepts the 2.5mm plug for the earpiece.
5. Pocket Clip — attaches microphone to user.

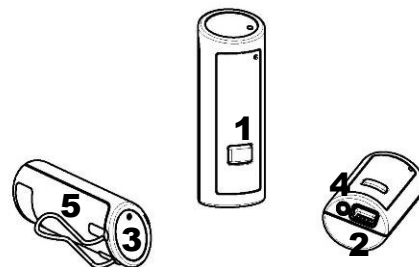

Charging the Batteries

How to Charge

1. Place microphone(s) into the Executive Charger Base.
2. During charging, the LED indicator turns on (RED) and remains on until charging completes. The microphones cannot be used while charging. The battery fully charges in approximately two hours, and can be “quick-charged” to approximately 80% capacity in 45 minutes.
3. When charging completes, the LED turns off and microphone is ready for use.

Note: A fully charged module battery provides approximately 8 hours of talk time.

When to Charge

First-time use — before you can use the wireless microphones, charge the self-contained battery for two hours in the Charger Base.

Recharging—when the orange light starts to flash on the microphone the battery needs recharging. Over time (years), batteries gradually wear down and require longer charging times. This is normal.

The Lithium Polymer rechargeable batteries that power the microphones are not user serviceable. Please contact your AV service provider for replacement instructions and to assure the proper disposal method is used.

Warning: Never dispose of batteries in a fire because they may explode.

Using the Microphone

1. Remove the microphone from the Charger Base. The microphones turn on and mute themselves automatically when removed from Charger Base, to reduce noise while being attached to clothing.
2. The wireless microphone has a clip on the back which allows the microphone to be easily clipped onto a shirt pocket, blouse or lapel. The microphone can also be clipped on to a lanyard and be worn around the neck. Attach the microphone to clothing or to a lanyard, as close to the mouth as possible (within 6 - 12 inches is recommended).
3. With the microphone in the wearing position, un-mute the microphone by pressing and releasing the **MUTE** button (confirm by viewing flashing GREEN LED).
4. To turn off microphones, return the microphone unit to the Charger Base or press and hold the **MUTE** button for ~10 seconds until the LED turns solid RED and turns off.
5. If the microphones are moved out of range of the Base Station (~30 meters) the connection will be dropped (LED flashes all colors) and the microphone will mute. When the microphone is moved back into range the connection will automatically be re-established to its original state.



Adjusting the Volume

The volume of the microphone is set at the factory and cannot be adjusted on the wireless microphone. Access to each channel is provided on the Base Station for external amplification.

Note: Moving the wireless microphone closer to the mouth will increase the volume.

To change the volume on the earpiece, use the dial on the earpiece wire. Turning the dial towards the earpiece will increase the volume, and turning the dial towards the microphone will decrease the volume. Use the attached clothing clip to secure the earpiece wire.



Solo Executive Base Station

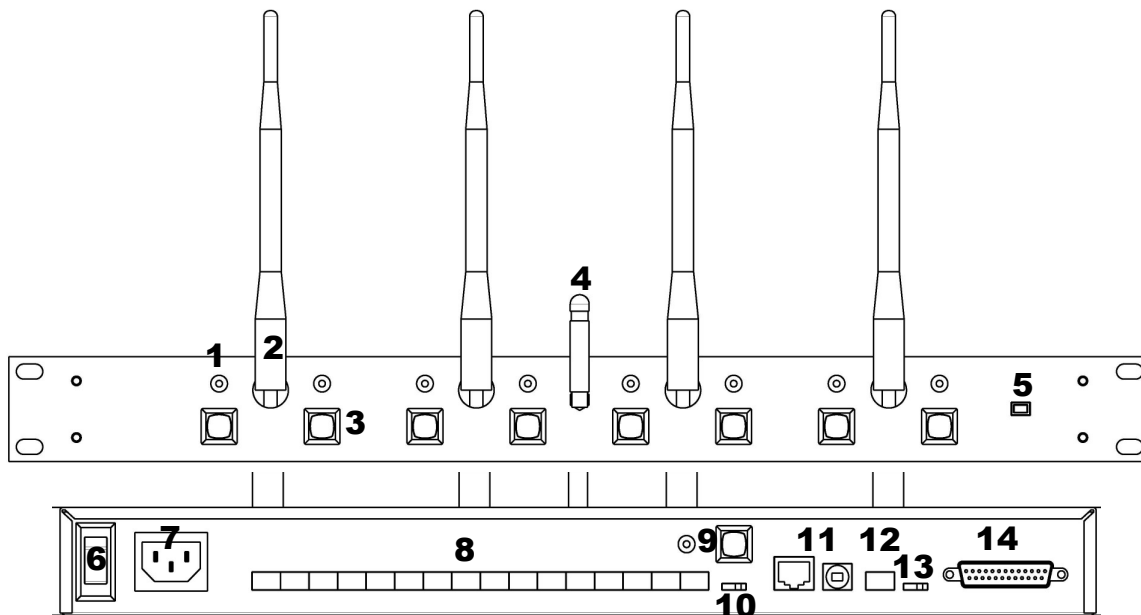

1. Channel LED indicators: Displays microphone and pairing states	8. Mini-Phoenix Connectors: Audio in and out connections (8 channels in, 8 channels out)
2. Diversity Antennae: Two sets	9. Pairing LEARN Button and Signal LED: For pairing Charger Mute to Base Station
3. Pairing Push Buttons: For pairing microphones to Base Station	10. Local/remote selector switch
4. Muting Antenna	11. USB and Ethernet Ports (<i>Future use</i>)
5. Power On LED	12. Multi-Base Station (BUS) synchronization connector (mini-Phoenix)
6. On/Off Switch: Powers up unit	13. System Mute function switch
7. Power In Connector (AC In)	14. DB25 Control Port (Parallel IO Port)

Installation

The Executive Base Station is easily installed into a standard 19" AV rack system using the supplied rack ears and standard rack screws. The equipment requires 110-220V AC, 50-60 Hz, power. Plug the power cord into an appropriate outlet and turn the circuit breaker-protected power switch on the back panel to **Reset**. The GREEN power LED on the front panel will illuminate. Attach the four diversity antennas (two on each side) and the system mute antenna (SMA male connector) in the center.

Connections

There are eight mini-phoenix input and output ports on the back panel of the unit providing access to each channel's audio signal. The provided mini-phoenix connectors are designed for easy wiring. The three terminals (from left to right) correspond to positive +, negative -, and ground ↓. Use the screws on top of the connector to first loosen the terminal to insert an appropriate 3 conductor cable (3 separate conductors, or 2 conductors and shield), and then tighten the screw to secure. Push the connector onto the pins centered under the desired input or output port until firmly secured.

There are eight output channels representing a separate channel for each microphone. Likewise, there are eight input channels to the unit. The microphone output connectors need to be attached to the line-level input connectors of an audio mixer. The Base Station input connectors should then be attached to mixer channel outputs. Because the system is full-duplex, the input connections provide the ability to hear program audio using the provided earpiece attached to the microphone. Depending on the application, it is possible to feed a single mixed channel back to all earpieces or, alternatively, each user can receive a separate and unique channel. This would allow for translation or other services to be incorporated into an application.

Set-up

The Base Station has eight indicator LEDs (one for each channel) and pairing push buttons on the front panel. When the LED is flashing green or red then that channel is active and connected to a wireless microphone (GREEN is for live audio, RED is for muted). When the LED is off, the channel is inactive (the microphone is out of range or turned off).

The front panel also has two sets of diversity antennae for best reception, and a fifth antenna for system mute reception. These antennae are removable for relocation by installation professionals, based on the installation environment and coverage optimization requirements.

Pairing Wireless Microphones to Base Station

"Pairing" creates a link between the wireless microphone and the Base Station with a unique electronic serial number. When the microphone and Base Station have been previously paired, the microphone will automatically try to connect to the Base Station whenever it is lifted from the Charger Base.

Remember, microphones are always muted (flashing Red LED) when they are removed from the Charger Base and the MUTE button needs to be pressed to make it "live" (flashing Green LED).

Microphones in new systems come paired to the Base Station with each microphone assigned to a unique channel on the base unit. However, if a replacement microphone is ever required, it will need to be manually “paired.”

If a microphone is lifted from the Charger Base and the LEDs continuously flash alternating Red, Green and Yellow, and the Base Station LEDs flash alternating Red and Green, the microphone needs to be paired to the system. Make sure that all other microphones are properly paired, and that the Base Station is powered on, before proceeding to pair an individual microphone. By noting which microphone channels are already in use (paired), it will be obvious which channel to use for pairing the microphone.

Microphone Pairing Instructions

1. First make sure the microphone is turned OFF (no LED activity). If the unit is ON, press and hold the **MUTE** button for 10 seconds until the LED turns solid RED (do not release when you hear two beeps), to turn the unit off, if needed.
2. Next, place the microphone unit into pairing mode by holding the **MUTE** button down for six seconds. The LED will turn solid GREEN and then solid RED. Release the **MUTE** button. The microphone unit is now in pairing mode.
3. Within one minute, push and hold the button for the desired channel on the Base Station for six seconds to enter into pairing mode. The LED for that channel will be solid RED until pairing starts, as indicated by a quick GREEN flash switching to flashing RED on both the microphone and the Base Station.

Pairing Charger Base to Base Station

“Pairing” is also used to create a link between the Charger Base **MUTE** control and the Base Station. When the Charger Base and Base Station are paired, the system mute function may be used.

The Charger Base in new systems come paired to the Base Station. However, if a replacement Charger Base is ever required, it will need to be manually “paired.”

System Mute Button Pairing Instructions

1. First, power-on the Charger Base and Base Station (power LEDs on both units are GREEN).
2. Next, place the Base Station system into pairing mode by briefly pressing the **LEARN** button on the rear connection panel. The pairing LED next to the **LEARN** button will illuminate.
3. Now press the **MUTE** button on the Charger Base once. The pairing LED on the back of the Base Station panel will go off and the power LED on the Charger Base will turn solid RED.
4. Press the **MUTE** button the Charger Base again. The pairing LED on the Base Station will flash twice and the power LED on the Charger Base will turn solid GREEN.
5. Once the pairing LED on the Base Station stops flashing the **MUTE** button on the Charger Base will mute all the microphones in the system.

Using Multiple Systems

If more than one Base Station is used in a room, each unit needs to be interconnected with a sync cable using the supplied mini-phoenix connectors. The three terminals correspond to positive +, negative -, and ground. Use the screws on top of the connector to first loosen the terminal to insert an appropriate three conductor cable (3 conductors, or 2 conductors and shield), and then tighten the screw to secure. Push the connector onto the pins labeled **BUS**. One box needs to be set as the **LOCAL** unit by sliding the switch next to the port to the left. The other units need to be set to the **REMOTE** setting by sliding their switch to the right. The **LOCAL** unit manages the entire system and allocates microphones across the available channels to maintain frequency integrity. **Note:** *The switch must be in the Local position for a single Base Station system. Microphones will not function if the switch is in the Remote position.*

System Mute Function Switch

In certain circumstances it is preferable to use the muting capabilities in a DSP based automated microphone mixer instead of the Charger Base system mute. This is the case when the mixer is providing acoustic echo cancellation and needs a continuous signal to maintain a near-end audio reference. The two position System Mute switch located on the back panel controls how the Base Station handles the audio output levels for muted channels.

Position 1 (left side - default): Base Station completely shuts off audio out of each channel that is in the mute state.

Position 2 (right side): Base Station leaves audio output of muted channel at the same level and signals the appropriate “mute out” pin on DB25 connector for line muting on external hardware.

Note: *The System Mute button on the Charger Base does not mute the system when the switch is in Position 2 (right side).*

DB25 Control Port

In connection with the System Mute switch, the DB25 Control Port allows the use of third party control systems using parallel port IO (active low, open collector). The pin-out status functions shown below can be used to provide system muting operations via third party products. The System Mute switch should be pushed all the way to the right for this feature to operate. Please see the operating manual for the control device for more information. The **MUTE_OUT** indicators are used to determine muted channels, and the **SYS_MUTE** mutes all channels.

DB25 Connector Pin	Function
Pin 1	Mute – Channel 1 output
Pin 3	Mute – Channel 2 output
Pin 5	Mute – Channel 3 output
Pin 7	Mute – Channel 4 output
Pin 9	Mute – Channel 5 output
Pin 11	Mute – Channel 6 output
Pin 13	Mute – Channel 7 output
Pin 15	Mute – Channel 8 output
Pin 2	System Mute – Input
Pin 25	Ground
Pin All Others	NA

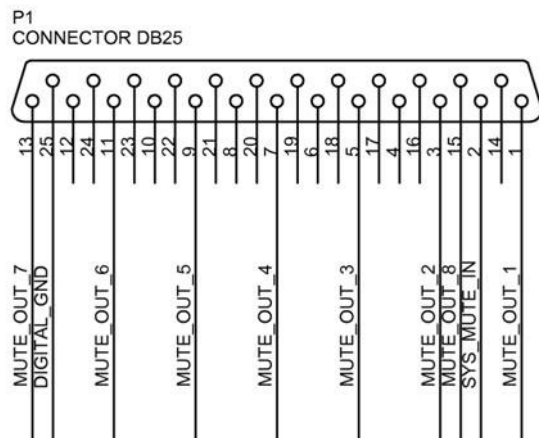

System Functions

The following table shows the functions supported by the Solo Executive System:

Function		
Base Station Status	Wireless Microphone Status	Action
Enter Pairing Mode		
On	Off	Press microphone MUTE button for 6 seconds, and then press the pairing button on the Base Station for 6 seconds.
Mute		
On	On	Short press of microphone MUTE button causes flashing RED LED indicating microphone has audio muted.
Turn Off Microphones		
On/Off	On	Press microphone MUTE button for approx. 10 seconds until LED stays solid RED to turn off microphone.
Turn On Microphones		
On/Off	Off	Quickly dock microphone into charge base Or Press & hold (3 Sec) microphone MUTE button until LED flashes on.

Note: If the link abnormally disconnects (for example, a microphone is worn out of range) the wireless microphone will try to re-establish the link for ~15 minutes, and then turn off automatically. The microphone will beep five times every 30 seconds as a reminder to return the microphone to the Charger Base.

System Specifications

Dimensions, (L, W, H) and Weight

Executive Base Station 16.9" (43.03cm) x 8.0" (20.32cm) x 1.7" (4.42cm), 6.5 lbs (2.95 kg)
Charger Base 8.3" (21.1cm) x 4.3" (10.9cm) x 1.0" (2.56 cm), 1 lb (0.45 kg)
Wireless Microphones 0.9" (2.4cm) x .8" (1.95cm) x 2.6" (6.68cm), 0.05 lbs (0.01 kg)

Radio Frequency 1.9 GHz (DECT)
315 MHz (System Mute)

Connectors Audio In/Out (Line Level) - Phoenix (3.5mm) quick connect terminal blocks
Sync In/Out - Phoenix (3.5mm) quick connect terminal block
Diversity Antennae - SMA Plug (50 ohm)
System Mute Antenna – SMA Jack (50 ohm)
Control Port - DB25 Socket
Ethernet - RJ45 (not used)
USB – Type A (not used)

Power Requirements

Executive Base Station 100-240V AC, 50-60 Hz, 5W (Universal Inputs)
Charger Base 100-240V AC, 50-60 Hz, 2 Amps

Range 100' (30 meters) approx. (no obstructions)

Channels Eight per Solo Executive System

Battery Lithium Polymer, up to 8 hours (talk time), 36 hours (stand by)

Charge Time 3.0 hours approx.

Audio Bandwidth 100-6800 Hz

Encryption 128-bit proprietary (per microphone channel)

Environmental Requirements

Temperature 5° to 40° C operating
Humidity 20% to 85%

Indicator LEDs

The following tables show activities associated with the various states shown by the LEDs on the Solo Executive System:

Equipment Use	Microphone LED	Base Station Channel LEDs	Meaning
Microphone in Charger Base	RED Solid	OFF	Charging in Progress
	OFF	OFF	Charging Complete
Microphone not in Charger Base	OFF	OFF	Microphone powered OFF or battery discharged
	RED Flashing	RED Flashing	Microphone muted
	GREEN Flashing	GREEN Flashing	Microphone "live"
	RED Solid	RED Solid	Microphone entering pairing mode
	8 RED Flashes	8 RED Flashes	Microphone pairing
	RED / GREEN Flashing	RED Flashing	Microphone pairing complete
	RED / GREEN Flashing	OFF	Microphone out of range and muted
	RED / GREEN / YELLOW Flashing	OFF	Microphone not paired
	RED / GREEN / YELLOW Flashing	GREEN Solid	Microphone low battery
	RED / GREEN / YELLOW Flashing	RED / GREEN Flashing	Microphone not paired or pairing failure

Note: The Base Station power LED will be green when power is on.

Equipment Use	Microphone LED	Charging Station LED	Meaning
Microphone in Charger Base	OFF	OFF	Unit is unplugged
Microphone not in Charger Base	GREEN Flashing	GREEN Solid	Microphone "live"
	RED Flashing	RED Flashing	Microphones muted using station mute

Audio Indicators

Equipment Use	Microphone	Earpiece	Meaning
Microphone not in Charger Base	Five rapid tones repeated every 30 seconds	No audio or deteriorating audio quality	Microphone out of range
		Five rapid tones repeated every 20 seconds	Low battery

Warranty

Revolabs, Inc. warrants this product to be free of manufacturing defects. Repair or replacement of any defective part or unit (at the discretion of the Seller) will be free of charge for the period of one year.

Any attempt by the user to alter the equipment, or equipment damaged by negligence, accident, or Acts of God voids this warranty.

The Seller shall not be liable for any consequential damage resulting from the malfunction of this product. Should the user experience unsatisfactory performance from this equipment, contact the Seller to obtain instructions for return, or replacement, as deemed necessary.

This warranty is not transferable by the original end user.

Revolabs, Inc.
63 Great Road
Maynard, MA 01754
www.revolabs.com

Safety and General Information

IMPORTANT INFORMATION ON SAFE AND EFFICIENT OPERATION. READ THIS INFORMATION BEFORE USING YOUR DEVICE.

FCC Notice to Users

Users are not permitted to make changes or modify the equipment in any way. Changes or modifications not expressly approved by Revolabs, Inc. could void the user's authority to operate the equipment.

This device complies with Part 15 of the FCC Rules. Operation is subject to the following two conditions: (1) this device may not cause harmful interference, and (2) this device must accept any interference received, including interference that may cause undesired operation.

Professional Installation

This product must be professionally installed.

Restricted use in certain types of facilities

To avoid electromagnetic interference and/or compatibility conflicts, turn off your device in any facility where posted notices instruct you to do so. Hospitals or health care facilities may be using equipment that is sensitive to external RF energy.

Restricted use with certain medical devices

Hearing Aids

Some devices may interfere with some hearing aids. In the event of such interference, you may want to consult with your hearing aid manufacturer to discuss alternatives.

Other Medical Devices

If you use any other personal medical device, consult the manufacturer of your device to determine if it is adequately shielded from RF energy. Your physician may be able to assist you in obtaining this information.

Industry Canada Notice to Users

Operation is subject to the following two conditions: (1) This device may not cause interference and (2) This device must accept any interference, including interference that may cause undesired operation of the device Ref IC: RSS 210 Sec. 5.11. The term "IC:" before the certification/registration number only signifies that registration was performed based on a Declaration of Conformity indicating that Industry Canada technical specifications were met. It does not imply that Industry Canada approved the equipment. See Ref IC Self-Marking 6(f) and RSP-100 Sec. 4.

Export Law Assurances

This product is controlled under the export regulations of the United States of America and Canada. The Governments of the United States of America and Canada may restrict the exportation or re-exportation of this product to certain destinations. For further information contact the U.S. Department of Commerce or the Canadian Department of Foreign Affairs and International Trade. The use of wireless devices and their accessories may be prohibited or restricted in certain areas. Always obey the laws and regulations on the use of these products.

NOTES